

MA4E2532L-1113
MA4E2532M-1113

Features

- Extremely Low Parasitic Capacitance and Inductance
- Surface Mountable in Microwave Circuits, No Wirebonds Required
- Rugged HMIC Construction with Polyimide Scratch Protection
- Reliable, Multilayer Metalization with a Diffusion Barrier, 100% Stabilization Bake (300 °C, 16 hours)
- Lower Susceptibility to ESD Damage

Description

The MA4E2532-1113 Series SurMount™ Low and Medium Barrier, Silicon Schottky Ring Quad Diodes are fabricated with the patented Heterolithic Microwave Integrated Circuit (HMIC) process. HMIC circuits consist of Silicon pedestals which form diodes or via conductors embedded in a glass dielectric, which acts as the low dispersion, low loss, microstrip transmission medium. The combination of silicon and glass allows HMIC devices to have excellent loss and power dissipation characteristics in a low profile, reliable device.

The Surmount Schottky devices are excellent choices for circuits requiring the small parasitics of a beam lead device coupled with the superior mechanical performance of a chip. The SurMount structure employs very low resistance silicon vias to connect the Schottky contacts to the metalized mounting pads on the bottom surface of the chip. These devices are reliable, repeatable, and a lower cost performance solution to conventional devices. They have lower susceptibility to electrostatic discharge than conventional beam lead Schottky diodes.

The multi-layer metalization employed in the fabrication of the Surmount Schottky junctions includes a platinum diffusion barrier, which permits all devices to be subjected to a 16-hour non-operating stabilization bake at 300 °C.

The “ 0505 ” outline allows for Surface Mount placement and multi-functional polarity orientations.

Applications

The MA4E2532 1113 Series SurMount™ Low and Medium Barrier, Silicon Schottky Ring Quad Diodes are recommended for use in microwave circuits through Ku band frequencies for lower power applications such as mixers, sub-harmonic mixers, detectors and limiters. The HMIC construction facilitates the direct replacement of more fragile beam lead diodes with the corresponding Surmount diode, which can be connected to a hard or soft substrate circuit with solder.

Case Style 1113

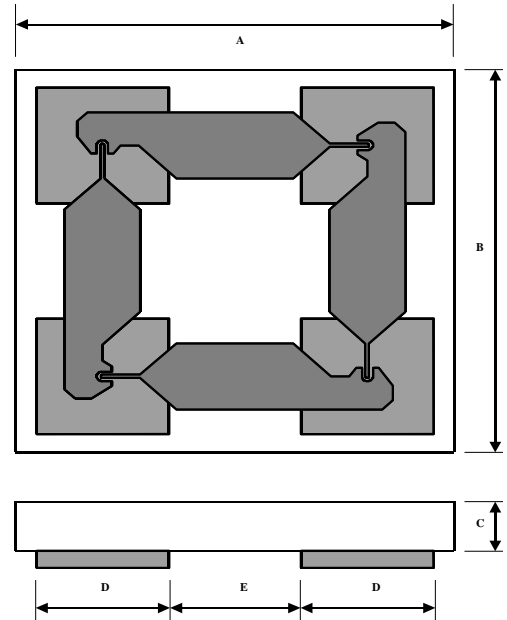

Dim	Inches		Millimeters	
	Min.	Max.	Min.	Max.
A	0.0445	0.0465	1.130	1.180
B	0.0445	0.0465	1.130	1.180
C	0.0040	0.0080	0.102	0.203
D Sq.	0.0128	0.0148	0.325	0.375
E	0.0128	0.0148	0.325	0.375

MA4E2532L-1113

MA4E2532M-1113

Equivalent Circuit

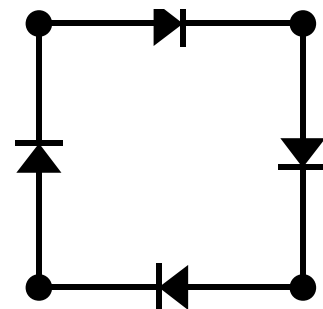

Electrical Specifications: @ 25 °C (Measured as Single Diodes)

Model Number	Type	Recommended Frequency Range	Vf @ 1 mA (mV)	DVf @ 1 mA (mV)	Ct @ 0 V (pF)	Rt Slope Resistance (Vf1 - Vf2)/(10.5 mA-9.5 mA) (W)
MA4E2532L-1113	Low Barrier	DC - 18 GHz	330 Max 300 Typ	10 Max	0.16 Max 0.10 Typ	16 Typ 20 Max
MA4E2532M-1113	Medium Barrier	DC - 18 GHz	470 Max 440 Typ	10 Max	0.18 Max 0.12 Typ	10 Typ 18 Max

Rt is the dynamic slope resistance where

$R_t = R_s + R_j$, where $R_j = 26 / I_{dc}$ (I_{dc} is in mA) and R_s is the Ohmic Resistance

Handling

All semiconductor chips should be handled with care to avoid damage or contamination from perspiration and skin oils. The use of plastic tipped tweezers or vacuum pickups is strongly recommended for individual components. The top surface of the die has a protective polyimide coating to minimize damage.

The rugged construction of these SurMount devices allows the use of standard handling and die attach techniques. It is important to note that industry standard electrostatic discharge (ESD) control is required at all times, due to the sensitive nature of Schottky junctions.

Bulk handling should insure that abrasion and mechanical shock are minimized.

Absolute Maximum Ratings¹

Parameter	Value
Operating Temperature	-40 °C to +150 °C
Storage Temperature	-40 °C to +150 °C
Junction Temperature	+175 °C
Forward Current	20 mA
Reverse Voltage (10 μA)	5 V
RF C.W. Incident Power	+ 20 dBm
RF & DC Dissipated Power	50 mW

1. Exceeding any of these values may result in permanent damage

Die Bonding

Die attach for these devices is made simple through the use of surface mount die attach technology. Mounting pads are conveniently located on the bottom surface of these devices, and are opposite the active junction. The devices are well suited for higher temperature solder attachment onto hard substrates. 80Au/20Sn and Sn63/Pb37/Ag2 solders are acceptable for usage.

For Hard substrates, we recommend utilizing a vacuum tip and force of 60 to 100 grams applied uniformly to the top surface of the device, using a hot gas bonder with equal heat applied across the bottom mounting pads of the device. When soldering to soft substrates, it is recommended to use a lead-tin interface at the circuit board mounting pads. Position the die so that its mounting pads are aligned with the circuit board mounting pads. Reflow the solder paste by applying Equal heat to the circuit at both die-mounting pads. The solder joint must Not be made one at a time, creating un-equal heat flow and thermal stress. Solder reflow should Not be performed by causing heat to flow through the top surface of the die. Since the HMIC glass is transparent, the edges of the mounting pads can be visually inspected through the die after die attach is completed.

MA4E2532L-1113 Low Barrier SPICE PARAMETERS (per Diode)*

Is (nA)	Rs (W)	N	Cj0 (pF)	M	Ik (mA)	Cjpar (pF)	Vj (V)	FC	BV (V)	IBV (mA)
26	12.8	1.20	1.0 E-2	0.5	14	9.0 E-2	8.0 E-2	0.5	5.0	1.0 E-2

MA4E2532M-1113 Medium Barrier SPICE PARAMETERS (per Diode)*

Is (nA)	Rs (W)	N	Cj0 (pF)	M	Ik (mA)	Cjpar (pF)	Vj (V)	FC	BV (V)	IBV (mA)
5 E-1	9.6	1.20	1.0 E-2	0.5	10	9.0 E-2	8.0 E-2	0.5	5.0	1.0 E-2

* Spice parameters (per Diode) are based on the MA4E2502 Series datasheet.

Circuit Mounting Dimensions (Inches)

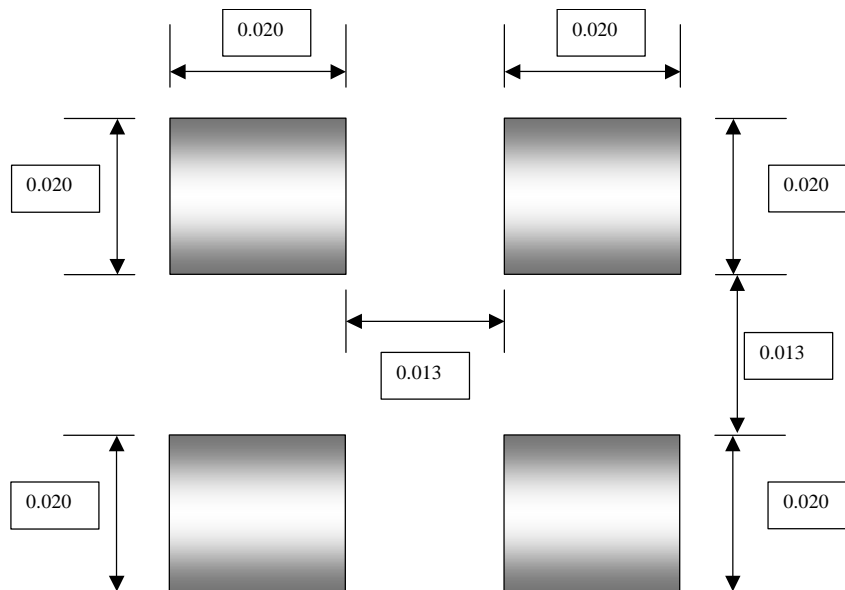

Ordering Information

Part Number	Package
MA4E2532L-1113W	Wafer on Frame
MA4E2532L-1113	Die in Carrier
MA4E2532L-1113T	Tape/Reel
MA4E2532M-1113W	Wafer on Frame
MA4E2532M-1113	Die in Carrier
MA4E2532M-1113T	Tape/Reel

MA4E2532 Series Schematic Per Diode

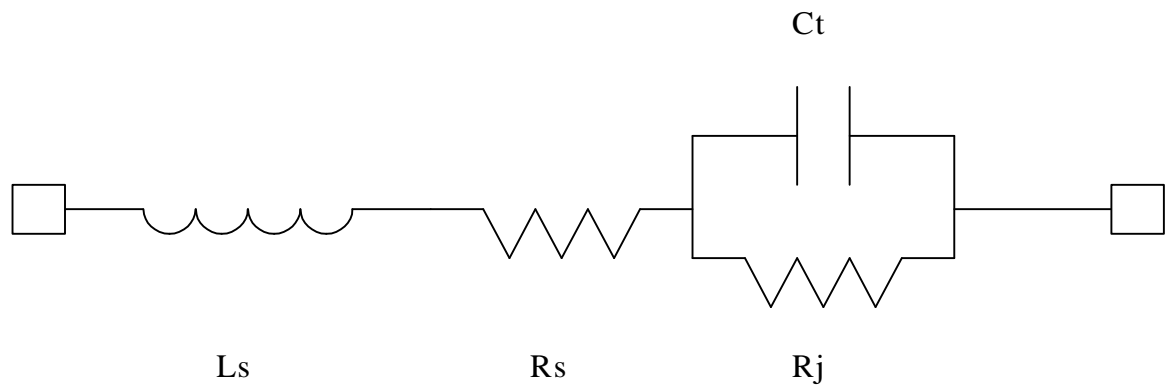

Average Schematic Values per Diode

Model Number	L_s (nH)	R_s (W)	R_j (W)	C_t (pF)
MA4E2532L-1113	0.8	13.4	26 / Idc	0.10
MA4E2532M-1113	0.8	9.4	26 / Idc	0.12