

### Application

For two-position operation of dampers, valves, and other equipment which require the return to normal position upon power interruption.

Hazardous location models offer a sturdy cast aluminum case with bolted cover. They have two 3/4" pipe tapped openings for joints with rigid metal conduit. All wiring is brought out to separate terminals for ease of installation. These factory enclosure and actuator assemblies are Underwriters Laboratories listed.

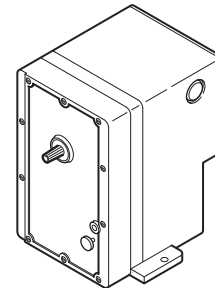

MA-3xx, MA5-318,  
MA-4xx, MA5-419  
(Standard)

### Features

- Compatible with most SPST control devices
- Spring return
- 24, 120, 208, and 240 Vac models
- Actuators with part number suffix "-500" are equipped with SPDT auxiliary switch
- Actuator has a rugged die cast aluminum housing with two 1/2" conduit openings
- Hazardous location actuator housing has two 3/4" pipe taped openings for rigid metal conduit connection
- Oil immersed motor and gear train

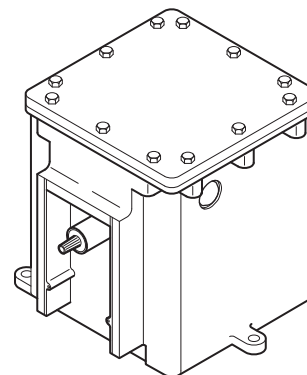

MA6-3xx, MA6-4xx, MA7-4xx,  
MA8-3xx, MA8-4xx  
(Hazardous Locations)

### Applicable Literature

- *Electric/Electronic Products Catalog*, F-27382
- *Valve Products Catalog*, F-27384
- *Cross-Reference Guide*, F-26789
- *AV-29x Valve Linkage for Hazardous Location Gear Train Actuators General Instructions*, F-27441.
- *Apparatus for Hazardous Locations EN-56-2*, F-18451.
- *AV-390 Series, Valve Linkage for Gear Train Actuators General Instructions*, F-24376.
- *Material Safety Data Sheet (MSDS) for BCS-51-168 Oil (Until Feb. 1989)*
- *Material Safety Data Sheet (MSDS) for BCS-51-185 Oil (Until March 2002) (MAx-3xx-x-x-3 and MAx-4xx-x-x-3)*
- *Material Safety Data Sheet (MSDS) for BCS-51-185-1 Oil (Current) (MAx-3xx-x-x-4 and MAx-4xx-x-x-4)*
- *High Temperature Exposure Performance (UL 555S) MAx-31x-x-x-4, MAx-41x-x-x-4 Series Actuators Engineering Information EN-216*, F-27068

# SPECIFICATIONS

## Actuator Inputs

**Connections:** Coded screw terminals.

**Control Circuit:** Two-wire.

**Power Input:** See Table-1.

## Actuator Outputs

**Torque:** See Table-1.

**Shaft Rotation:**

**MA-305, MA-405, MA6-305, MA6-405,** CW 180° when power is applied.

**MA-318, MA-41x, MAx-318, MAx-41x,** CW 180° when power is applied.

**Spring Return:** CCW to the original position when the actuator is de-energized.

**Auxiliary Switch (-500 Models):** SPDT makes (or breaks) the circuit at the powered end of stroke.

## Environment

**Ambient Temperature Limits:**

**Shipping & Storage,** -40 to 136 °F (-40 to 58 °C).

**Operating,** -40 to 136 °F (-40 to 58 °C).

**Humidity:** 5 to 95% RH, non-condensing.

**Location:** NEMA Type 4 when used with the gasket (provided) and water-tight conduit connectors (not provided), optional hazardous location models.

**Agency Listings:**

**US Standard UL 873,** Underwriters Laboratories (File #E9429 XAPX, Temperature Indicating and Regulating Equipment).

**Canadian Standard C22.2 No. 24:** Underwriters Laboratories (File #E429 Category XAPX7, Temperature Indicating and Regulating Equipment).

**Hazardous Location Models,** UL file #E29291. Designed for use in hazardous locations N.E.C., Class 1, Groups C and D, and Class 2, Groups E, F, and G. Temperature code T6 for hazardous housing.

**Table-1 Model Chart.**

Part Number	Power Supply		Auxiliary Switch <sup>a</sup>	Input Watts	VA		Rated Torque lb-in. (N-m)	No Load Timing in Seconds at 75 °F (24 °C) <sup>b</sup>	Mounting	Application
	Vac	Hz			Running	Holding				
MA-305	24	60	No	25	56	56	16 (1.8)	20	Any Position (Horizontal Output Shaft Position Preferred)	Damper Actuators
MA-305-500			Yes							
MA-405	120		No		48	48				
MA-405-500			Yes							
MA-318	24	60	No	70 Running	92	32	60 (6.8)	Output Shaft Must Be Horizontal	Damper and Valve Actuators	
MA-318-500			Yes							
MA-416	208		No		104	38				
MA-416-500			Yes							
MA-418	120	60	No	25 Holding	108	42	60 (6.8)	Output Shaft Must Be Horizontal	Damper and Valve Actuators	
MA-418-500			Yes							
MA-419	240		No		120	39				
MA-419-500			Yes							
MA5-419		50	No							
MA5-419-500			Yes							

a 4.4 FLA, 26.4 LRA @ 24 or 120 Vac; 2.4 FLA, 13.2 LRA @ 240 Vac.

b Spring return timing with full load opposing spring is approximately 60 sec.

**Table-2 Actuator Part Numbers for Hazardous Location Applications.**

Standard Part Numbers <sup>a</sup>	Hazardous Location Actuator Assemblies Part Numbers <sup>b c d</sup>	
	Damper Actuators	Valve Actuators
MA-305	MA6-305	—
MA-305-500	—	—
MA-405	MA6-405	—
MA-405-500	MA6-405-500	—
MA-318	MA6-318	MA8-318
MA-318-500	MA6-318-500	MA8-318-500
MA-416	MA6-416	—
MA-416-500	MA6-416-500	—
MA-418	MA6-418	MA8-418
MA-418-500	MA6-418-500	MA8-418-500
MA-419	MA6-419	—
MA-419-500	MA6-419-500	—
MA5-419	MA7-419	—
MA5-419-500	MA7-419-500	—

<sup>a</sup> MAx-31x-x-x-4 and MAx-41x-x-x-4 series actuators provide significantly improved high temperature exposure performance for use in smoke or fire dampers, or combination smoke and fire dampers. Refer to Engineering Information EN-216 (UL 555S), F-27068.

<sup>b</sup> Class 1, Groups C & D, and Class 2, Groups E, F, and G hazardous locations; refer to EN-56-2.

<sup>c</sup> Models for hazardous locations are only available as factory-built enclosure/actuator assemblies.

<sup>d</sup> See standard actuator part number wiring diagrams for wiring terminations.

## ACCESSORIES

### Damper Only

AM-111	Crank arm for 5/16" diameter damper shaft
AM-112	Crank arm for 3/8" diameter damper shaft
AM-113	Crank arm for 1/2" diameter damper shaft
AM-115	Crank arm for 7/16" diameter damper shaft
AM-122	Linkage connector straight type
AM-123	Damper clip
AM-125	5/16" diameter x 20" damper rod
AM-125-048	5/16" diameter x 48" damper rod
AM-132	Ball joint connector
AM-161	Damper linkage kit
AM-161-1	Damper linkage kit
AM-301	90° mounting bracket (not used with MA6-xxx, MA7-xxx, & MA8-xxx)

### Valve Only (To be used with 60 lb-in. (6.8 N-m) actuators only, excluding MA7-xxx & MA8-xxx)

AV-29 & AV-300	Linkage for 2-1/2" & 3" discontinued VB-9323
AV-391	Linkage for 1/2" to 2" VB-7xxx and 1/2" to 1-1/4" discontinued VB-9xxx
AV-392	Linkage for 1-1/2" and 2" discontinued VB-9xxx
AV-395	Linkage for 2-1/2" to 4" VB-931x or discontinued VB-92xx

### Valve Only (To be used with 60 lb-in. (6.8 N-m) MA7-xxx & MA8-xxx hazardous location actuators only)

AV-291	Linkage for 1/2" to 2" VB-7xxx valves assembled with hazardous location actuator assemblies.
AV-295	Linkage for 2-1/2" and 3" VB-9xxx valves assembled with hazardous location actuator assemblies.

## TYPICAL APPLICATIONS (Wiring Diagrams)

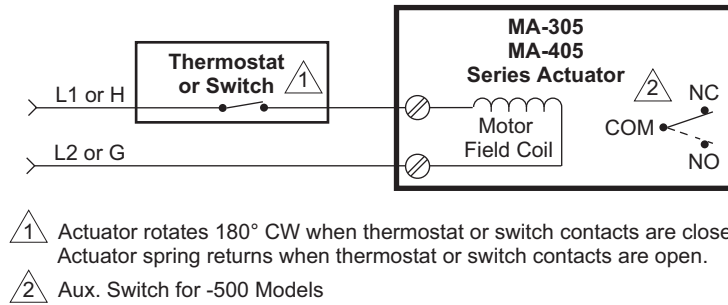

Figure-1 Typical Wiring for MA-305 and MA-405 Series.

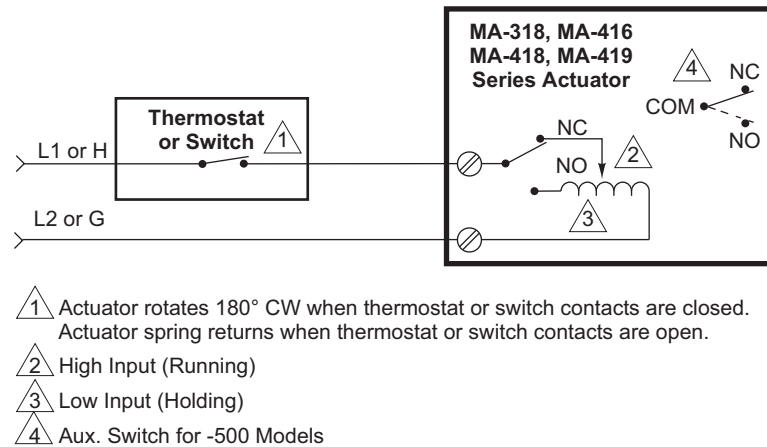

Figure-2 Typical Wiring for MA-318, MA-416, MA-418, and MA-419 Series.

# INSTALLATION

## Inspection

Inspect the package for damage. If damaged, notify the appropriate carrier immediately. If undamaged, open the package and inspect the device for obvious damage. Return damaged products.

## Requirements

- Job wiring diagrams
- Tools (not provided):
  - Digital Volt-ohm Meter (DVM)
  - Appropriate screwdriver(s) for cover and mounting screws
  - Appropriate drill and drill bit for mounting screws
  - Appropriate wrenches for adjustment of damper and valve linkages
- Appropriate accessories
- Mounting screws (not provided)
- Training: Installer must be a qualified, experienced technician



---

### Warning:

- Disconnect the power supply (line power) before installation to prevent electrical shock and equipment damage.
- Make all connections in accordance with the wiring diagram and in accordance with national and local electrical codes. *Use copper conductors only.*

---

### Caution:

- Do not apply power to the unit unless the damper linkage and/or the valve assembly have been installed.
- Avoid locations where excessive oil, dust, moisture, corrosive fumes or vibration, or an explosive atmosphere is present. The actuator case is intended primarily to provide a degree of protection against windblown dust, rain, sleet, and external ice formation (NEMA Type 4).

## Mounting

Mount the actuator according to the following requirements:

1. Allow a minimum of 6" (152 mm) clearance behind the actuator for access to the wiring compartment.
2. Locate the actuator in a weather-protected area.
3. To ensure water and weather resistance, install the cover gasket (provided) and use water-tight conduit fittings.

### Dampers

Install the actuator and the damper linkage, so that 180° of actuator shaft rotation drives 90° of damper shaft rotation, as follows:

#### Actuator Mounting and Damper Linkage Installation

1. Mount the actuator in an appropriate position near the damper.

---

### Note:

- MA-305 and MA-405 series actuators are not position-sensitive, and in damper applications, may be mounted in any position. However, the upright position is preferred.
- MA-318, MA-416, MA-418, and MA-419 series actuators must be mounted so that the output shaft lies in a horizontal position.
- To the extent possible, position the actuator to optimize the length of the damper rod needed to link it with the damper. A damper rod that is too long is not rigid enough for good control, and a damper rod that is too short makes it difficult to adjust the linkage.

2. Install crank arms onto the driven shaft and the actuator shaft. Tighten the crank arm on the driven shaft. Do not tighten the crank arm on the actuator shaft at this time.
3. Install a linkage connector onto the actuator shaft crank arm, at the prick point. Refer to (Figure-3) and (Figure-4).

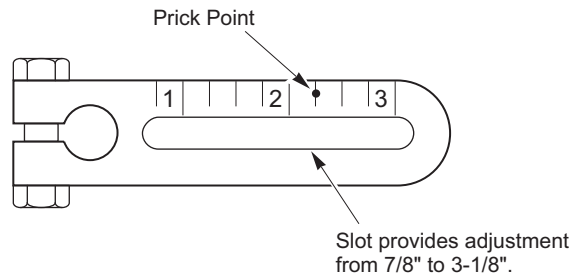

Figure-3 Location of Prick Point on Crank Arm.

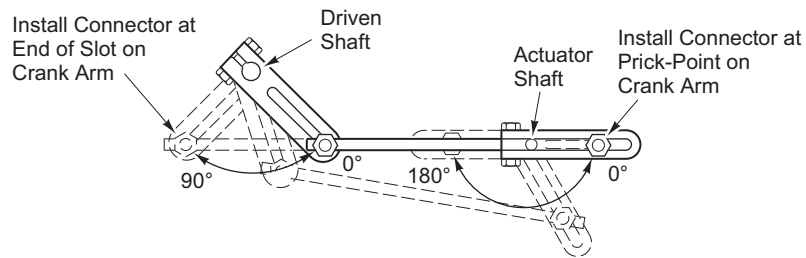

Figure-4 180° Actuator Rotation Driving a Damper Rotation of 90°.

4. Install a linkage connector onto the driven shaft crank arm, at the end of the slot. Refer to (Figure-4).
5. Install the damper rod in the linkage connectors on both crank arms and tighten the linkage connector screws finger-tight.

---

**Caution:** Never attempt to turn the actuator shaft with a wrench or a crank; this may damage the actuator.

---

#### Linkage Adjustment

1. Verify that the crank arm on the actuator shaft is loose. Rotate, by hand, the crank arm on the actuator to drive the linkage and the damper shaft through its full stroke, to ensure proper damper action.
2. For *normally closed* dampers, proceed as follows:
  - a. Return the damper to the closed position.
  - b. Tighten the crank arm on the actuator shaft.
  - c. Loosen the screw on one of the linkage connectors.
  - d. While pushing the damper closed, tighten the linkage connector screws to secure the damper rod.
3. For *normally open* dampers, proceed as follows:
  - a. Move the damper to approximately 85° of the full open position.
  - b. Tighten the crank arm on the actuator shaft.
  - c. Tighten the linkage connector screws to secure the damper rod.
4. Run the actuator back and forth through its full stroke and check for proper damper and linkage operation. Adjust the linkage if required.

---

**Caution:** When linking an actuator to a damper, be sure that it can complete its full stroke. If the damper stops the actuator before it has reached its electrical limit of travel on the power stroke, the actuator may be permanently damaged. Readjust the linkage as necessary.

---

## Valves

### Note:

When mounting an actuator onto a valve, observe the following:

- Allow 3" (76 mm) of clearance above the assembled actuator and valve for the removal and reattachment of the actuator.
- Always install single-seat valves with pressure under the seat.
- Install all two-way valves so that they close against the flow. A tag or an arrow on the valve body indicates proper flow direction.
- Always install three-way mixing valves with two inlets and one outlet.
- Always install three-way diverting valves with one inlet and two outlets.
- For steam applications only, mount the actuator above the valve body at 45° from the vertical.
- MA-318, MA-416, MA-418, and MA-419 series actuators can be mounted in any upright position above the centerline of the valve body. However, the output shaft must lie in a horizontal position.

For detailed valve linkage installation instructions, refer to *AV-29x Valve Linkage for Hazardous Location Gear Train Actuators General Instructions, F-27441* or *AV-390 Series, Valve Linkage for Gear Train Actuators General Instructions, F-24376*.

Refer to Figure-5 for the components of a typical valve installation of a standard actuator. For installing an actuator with a hazardous location housing, refer to Figure-6.

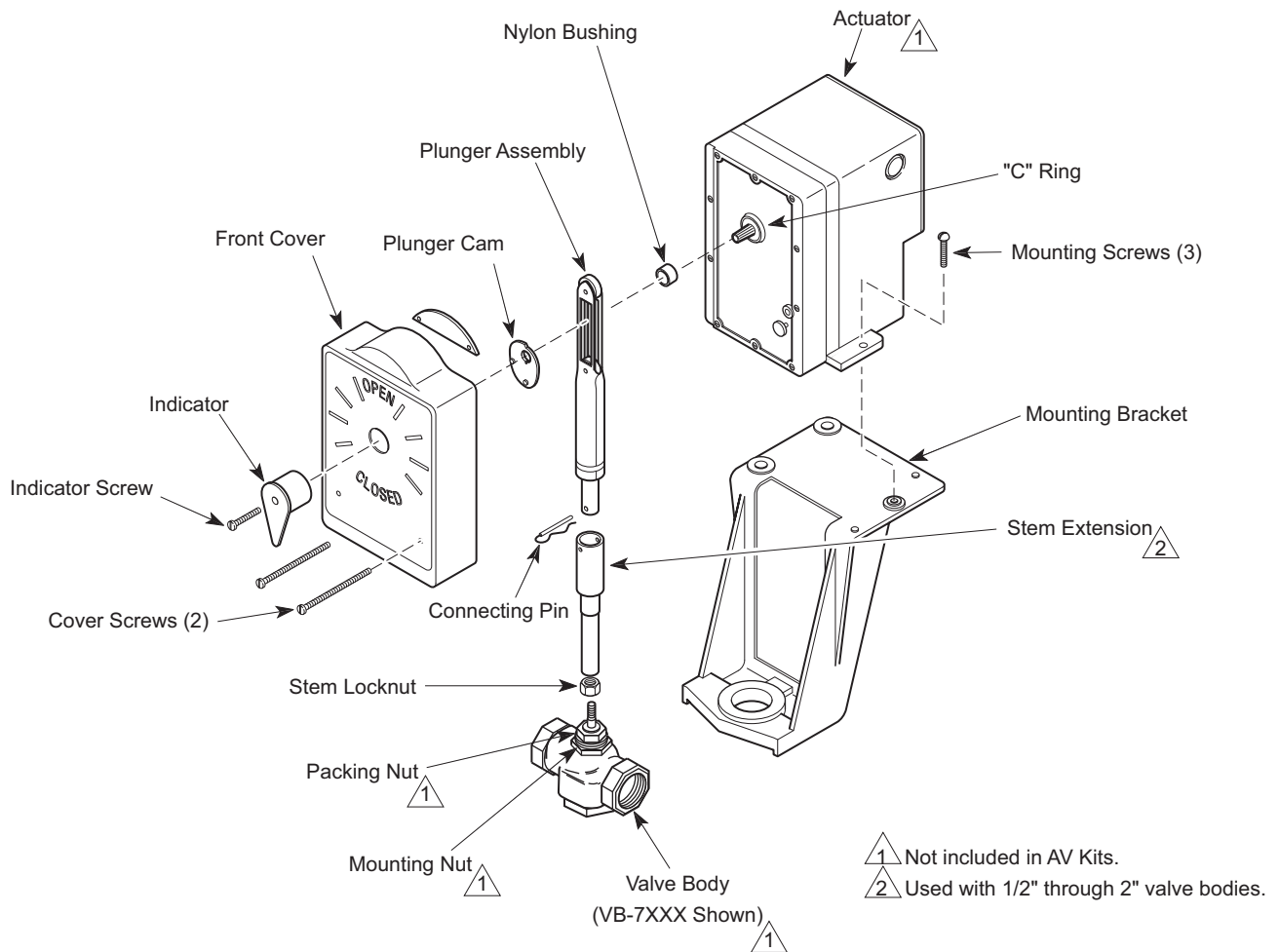

Figure-5 Typical Components for Valve Installation of Standard Actuator.

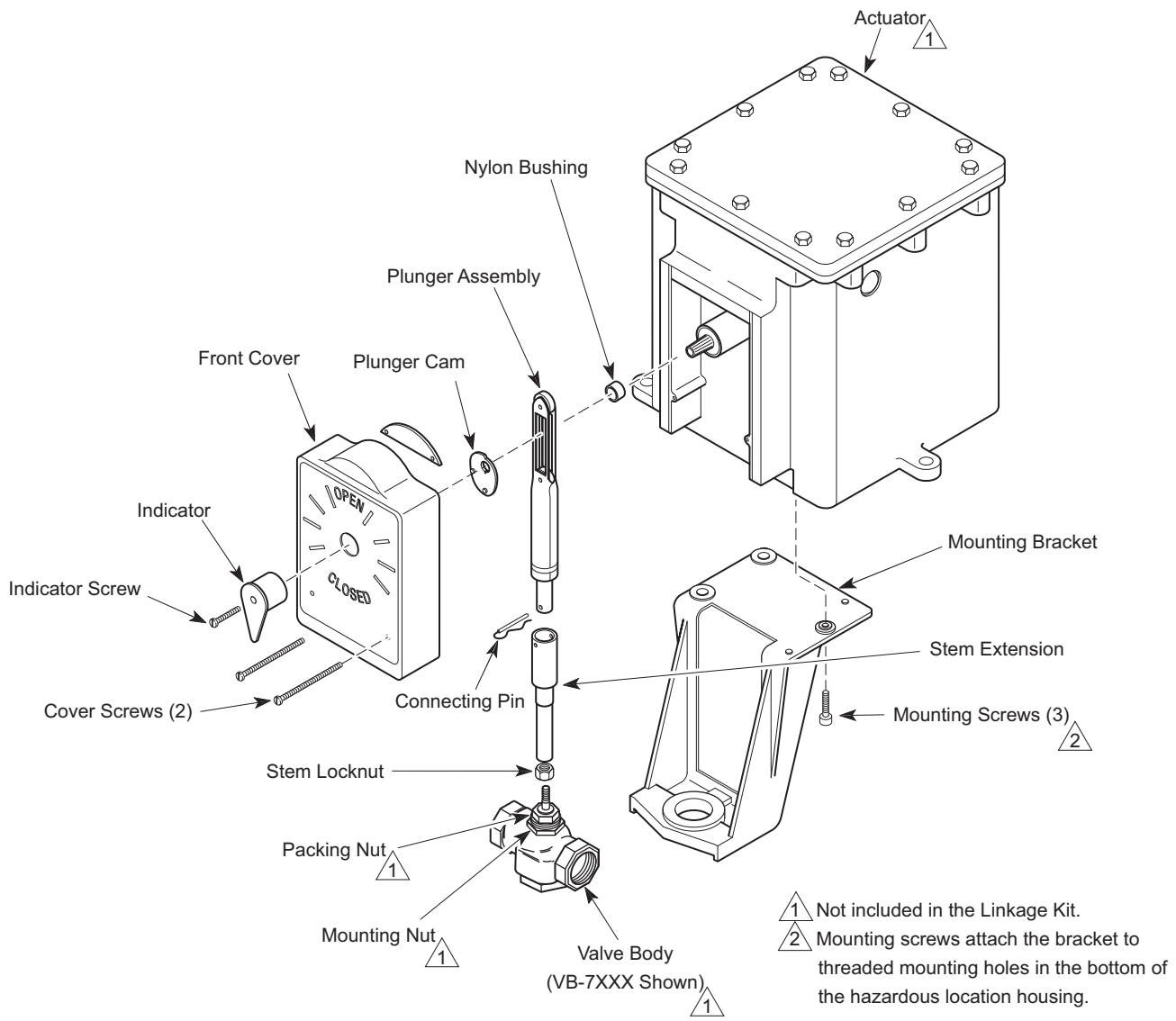

Figure-6 Typical Components for Valve Installation of Hazardous Location Actuator.



# WIRING

## Hazardous Location Models

Make all electrical connections to the assembly in accordance with the job wiring diagram, the National Electric Code Article 500, and in compliance with the local electrical codes.

Two 3/4" pipe tapped openings are provided in the housing for rigid conduit connections. It is recommended to insert a chase nipple from inside of the housing to prevent threads from cutting or damaging wiring.

When wiring, take care to lay all leads in the wiring channel located just under the housing cover to protect the leads from any sharp edges which may be in the vicinity.

The housing and the edge of the cover are stamped with the letter "O." When replacing the cover, the letters must be aligned with each other.



---

**Warning:** The cover-to-housing orientation must be maintained in order to preserve the integrity of the seal. Failure to observe this warning can result in injury or death.

---

1. Remove twelve cover screws and cover. Place cover, machined surface up, in a protected location to avoid damage to machined surfaces.
2. Make all wiring connections to actuator taking care to lay all leads in the wiring channel provided.
3. Before enclosing the actuator, wipe machined surfaces of housing clean with a lint free cloth and apply one of the UL approved compounds. See Note below.



---

**Warning:** Failure to observe these warnings can result in injury or death.

- Do not scrape, scratch, or use abrasives on the machined surfaces.
  - Ensure the surfaces are clean.
  - Use only the approved compounds listed below.
- 

4. Secure cover tight against the enclosure in the same position before removal with the twelve screws provided.

---

**Note:** Underwriters Laboratories has sanctioned the use of the following compounds on hazardous location ground joints: Crouse-Hinds type OSL lubricant, Crouse-Hinds type STL lubricant, or "No-OXID" oil, grade "D."

---

Two 1/2" conduit knockouts are provided on the actuator case.

Refer to Figure-7 for terminal locations.

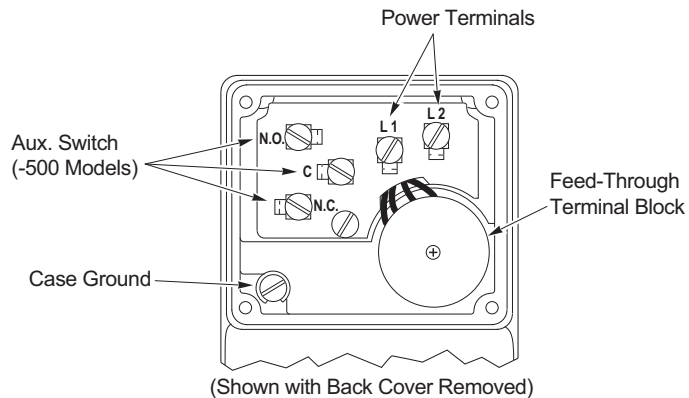

Figure-7 Actuator Terminal Locations.

Refer to Table-3 for the selection of the proper gage wire for the length of the wire run.

**Table-3 Power Wire Selection.**

Actuator Series	Wire Size AWG	Maximum Run <sup>a b</sup> ft (m)
MA-305	14	122 (37)
	12	191 (58)
	10	305 (93)
MA-405	14	2800 (853)
MA-318	14	44 (13)
	12	68 (21)
	10	110 (34)
MA-416, MA-418, MA-419	14	950 (290)
	12	1580 (482)

a Each run has two wires.

b The length given is for a maximum two-wire run, for one actuator. When multiple actuators are used, determine the maximum run for each actuator by dividing the number of actuators into the corresponding maximum run.

## CHECKOUT

After the entire system has been installed and the actuator has been powered up, perform the following check for proper system operation. Check for the correct operation of the damper while the actuator is being stroked.

---

*Note:* Smoke control systems must be tested in accordance with NFPA Standard 92A.

---

1. Verify that the system wiring is properly connected and powered.
2. Be sure the controller (manual or automatic) is operating properly according to system requirements.
3. When the controller energizes the actuator, the output shaft must run to the end of the stroke (180° CW).
4. When the controller de-energizes the actuator, the spring will return the output shaft to its original position.
5. The action of the auxiliary switch (-500 models only) shall be as follows:
  - a. C makes to N.C. when the actuator is de-energized. Refer to (Figure-8).
  - b. C makes to N.O. when the actuator is energized and the output shaft reaches the end of the stroke.

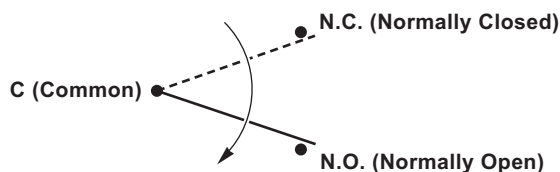

N.O. makes when actuator is energized and output shaft reaches end of stroke.

Figure-8 Action of Auxiliary Switch (-500 Models Only).

## THEORY OF OPERATION

MA-305 and MA-405 series actuator output shafts rotate 180° clockwise when energized and spring return counterclockwise to 0° when de-energized.

MA-31x and MA-41x series actuator output shafts rotate 170° clockwise when energized and spring return counterclockwise when de-energized.

MA-305 and MA-405 series actuator motors are assembled to a gear train and stall at the end of the power stroke.

MA-318, MA-416, MA-418, and MA-419 series actuators have an end of travel switch which reduces the running input from 70 watts to 25 watts at the end of clockwise shaft rotation.

## MAINTENANCE

**Caution:** MA-300 series and MA-400 series actuators that are used in applications where they are energized for extended periods of time must be electrically cycled at least once every six months to ensure correct operation.

Regular maintenance of the total system is recommended to assure sustained, optimum performance.

## FIELD REPAIR

None. Replace an inoperative actuator with a functional unit.

## DIMENSIONAL DATA

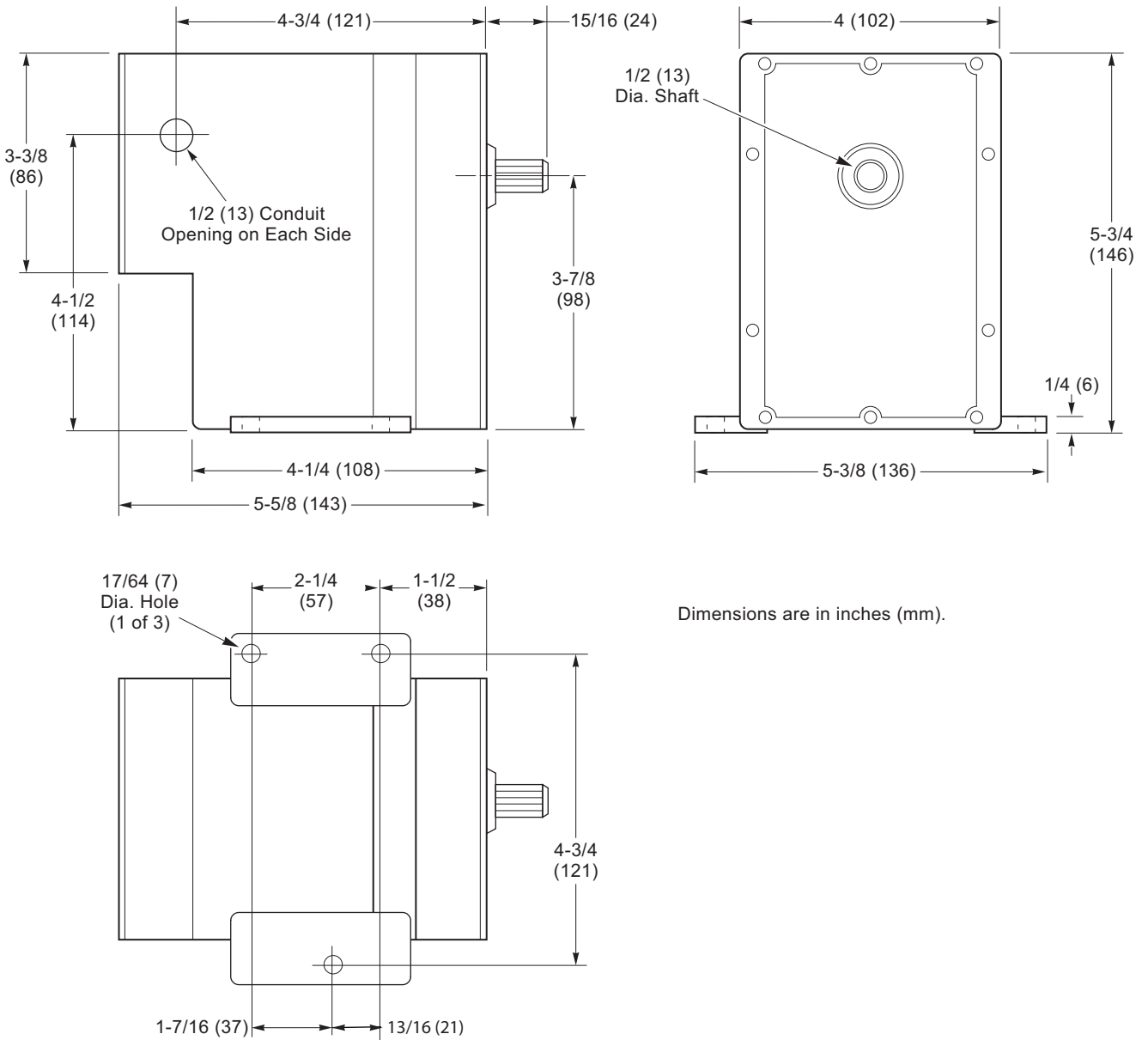

Figure-9 Dimensions of MA-3xx, MA5-318, MA-4xx, and MA5-419 (Standard) Actuators.

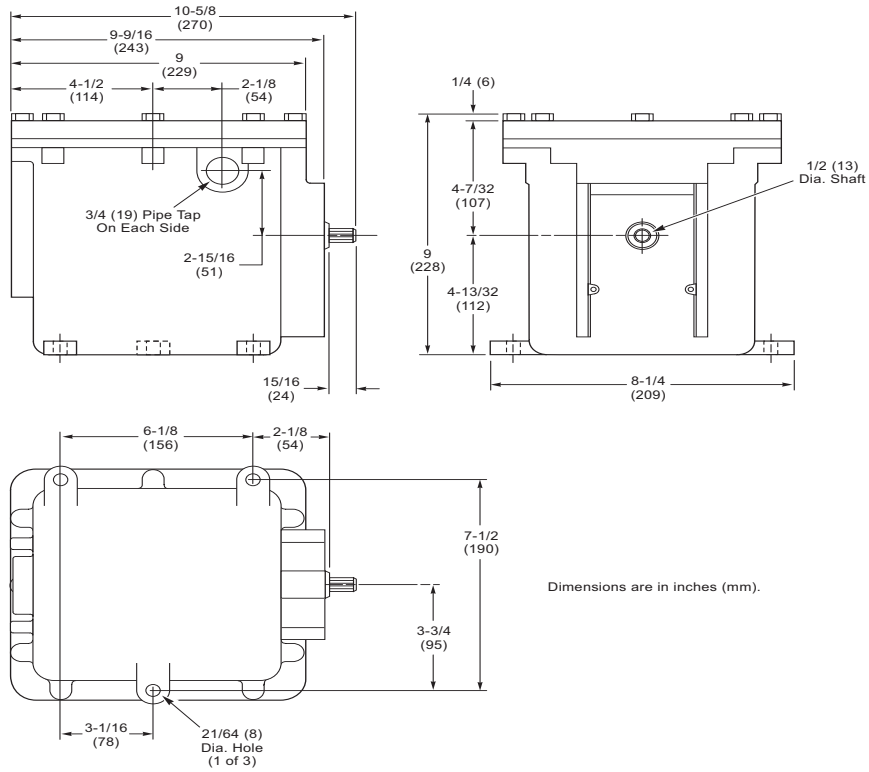

Figure-10 Dimensions of MA6-3xx, MA6-4xx, and MA7-4xx Damper Actuators for Hazardous Locations.

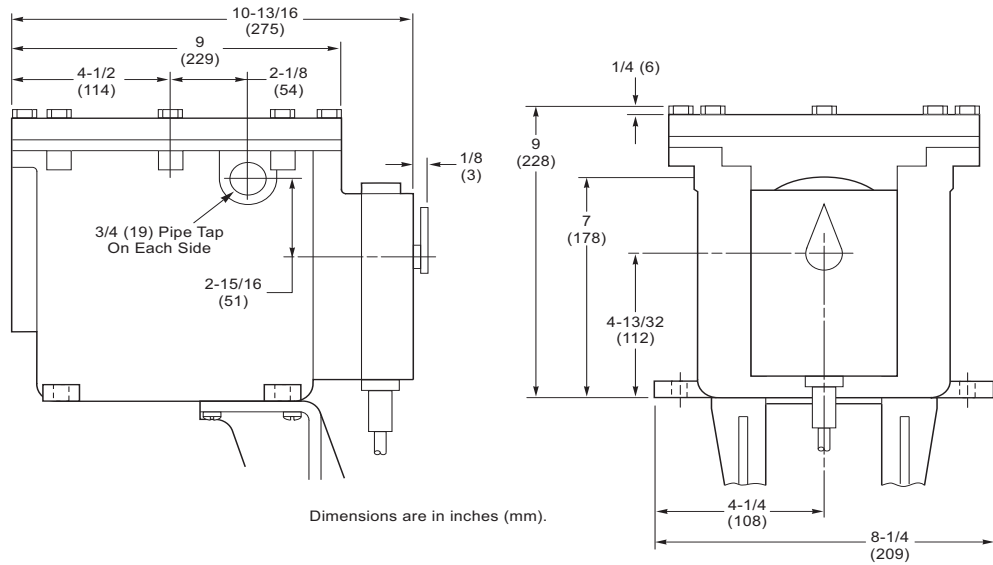

Figure-11 Dimensions of MA7-4xx, MA8-3xx, and MA8-4xx Valve Actuators for Hazardous Locations.