

## 38V Synchronous Buck for LED Driver

### ❖ GENERAL DESCRIPTION

The MA5603 is a monolithic synchronous buck regulator, and step-down converter designed for driving up to 10 series white LEDs from a 38V system input. The total LED driving current up to 2.5A, which is measured through an external current sense resistor. Its low 200mV feedback voltage reduces power loss and improves efficiency. The MA5603 includes current limit, short circuit protection and thermal shutdown protection preventing damage.

An internal soft-start prevents inrush current at turn-on, This device, available in an SOP8L-EP(Exposed pad) package, provides a very compact solution with minimal external components.

### ❖ FEATURES

- Wide 8V to 38V Operating Input Range
- Integrated two 140mΩ Power MOSFET Switches
- Feedback Voltage : 200mV
- Internal Soft-Start / VFB Over Voltage Protection
- Stable with Low ESR Ceramic Output Capacitors
- Fixed 240KHz Frequency
- Current Limit , Thermal Shutdown and Short Circuit Protections (SCP).
- Input Under/Over Voltage Lockout

### ❖ APPLICATION CIRCUIT

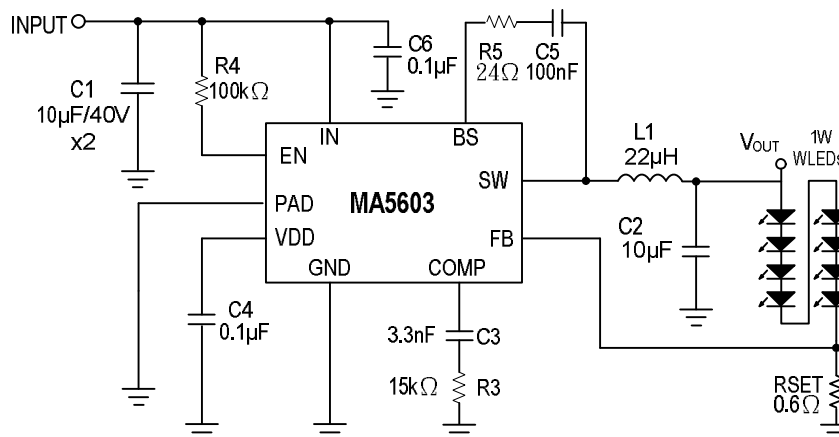

$$I_{LED} = V_{FB} / R_{SET} = 0.2V / 0.6\Omega = 0.330A, \quad V_{FB} = 0.2V.$$

## ❖ PIN ASSIGNMENT

The package of MA5603 is SOP8L-EP(Exposed pad); the pin assignment is given by:

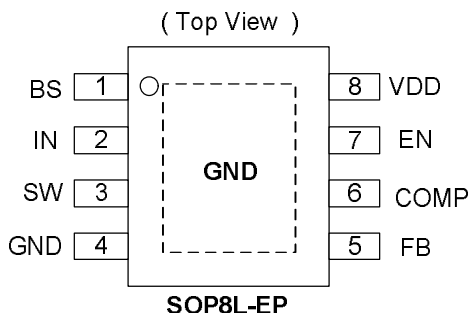

Name	Description
<b>BS</b>	Boot-Strap Pin. Supply high side gate driver. Decouple this pin to LX pin with 24ohm + 0.1uF ceramic cap.
<b>IN</b>	Power Input pin. Bypass IN to GND with a suitably large capacitor to eliminate noise on the input to the IC.
<b>SW</b>	Power Switching Output. SW is the switching node that supplies power to the output. Connect the output LC filter from SW to the output load.
<b>GND</b>	Ground.
<b>PAD</b>	Ground (Connect to GND).
<b>FB</b>	Feedback Input. FB senses the output voltage to regulate that voltage. Drive FB with a resistive voltage divider from the output voltage.
<b>COMP</b>	Compensation Node. COMP is used to compensate the regulation control loop. Connect a series RC network from COMP to GND to compensate the regulation control loop.
<b>EN</b>	Enable control. Pull high to turn on. Do not float.
<b>VDD</b>	Internal regulator pin

## ❖ RDER/MARKING INFORMATION

Order Information	Top Marking (SOP-8L)
<p><b>MA5603 XXX</b> → Packing Blank: Tube A: Taping</p> <p>Package Type ES: SOP8L-EP</p>	<p>Logo ← <b>MA5603</b> → Part number</p> <p>XXXXX → ID code:internal</p> <p>          → WW:01~52</p> <p>          → Year:12=2012</p>

## ❖ BLOCK DIAGRAM

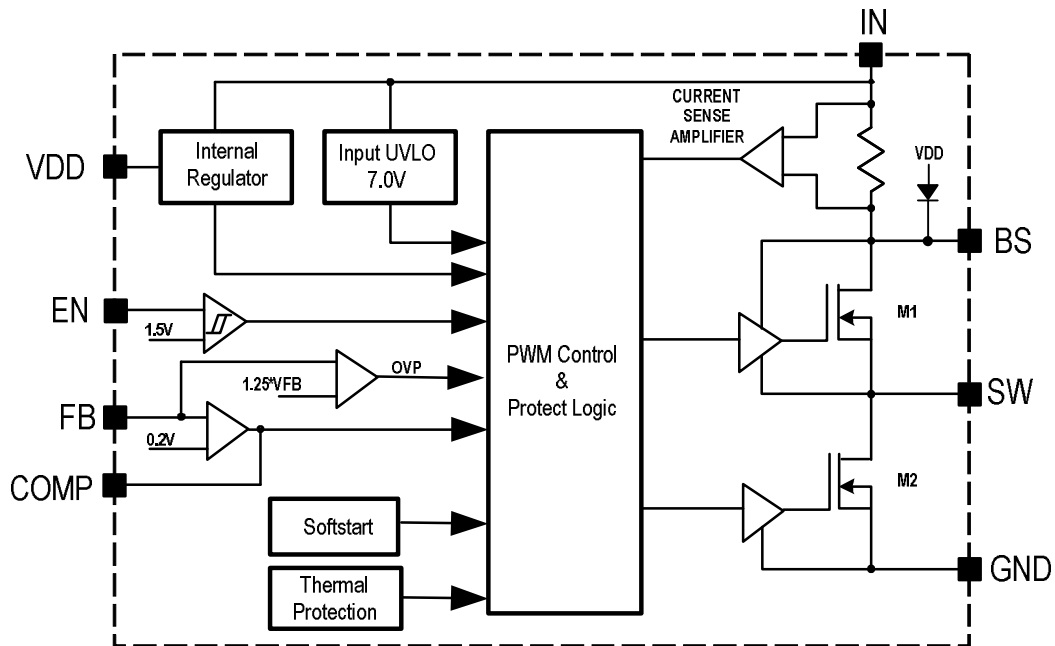

## ❖ ABSOLUTE MAXIMUM RATINGS (at $T_A=25^\circ\text{C}$ )

Characteristics	Symbol	Rating	Unit
Supply Voltage	$V_{IN}$	-0.3 to +42	V
Switch Node Voltage	$V_{SW}$	-0.3 to $V_{IN} + 0.3$	V
Boost Voltage	$V_{BS}$	$V_{SW} - 0.3$ to $V_{SW} + 6$	V
All Other Pins		-0.3 to +6	V
Lead Temperature		260	$^\circ\text{C}$
Storage Temperature		-65 to +150	$^\circ\text{C}$
Junction Temperature	$T_J$	150	$^\circ\text{C}$
Output Voltage	$V_{OUT}$	VFB to 33	V
Ambient Operating Temperature		-40 to +85	$^\circ\text{C}$
Thermal Resistance from Junction to case	$\theta_{JC}$	15	$^\circ\text{C/W}$
Thermal Resistance from Junction to ambient	$\theta_{JA}$	40	$^\circ\text{C/W}$

Note:  $\theta_{JA}$  is measured with the PCB copper area of approximately 1 in<sup>2</sup>(Multi-layer). That need connect to exposed pad.

**❖ ELECTRICAL CHARACTERISTICS**

 (V<sub>IN</sub> = 12V, T<sub>A</sub> = +25°C, unless otherwise noted.)

Characteristics	Symbol	Conditions	Min	Typ	Max	Units
Input Voltage Range			8	-	38	V
Shutdown Supply Current	I <sub>SD</sub>	V <sub>EN</sub> = 0V	-	0.7	1.3	mA
Quiescent Current	I <sub>CCQ</sub>	V <sub>EN</sub> = 5V; V <sub>FB</sub> = 0.21V	-	0.7	1.5	mA
Feedback Voltage	V <sub>FB</sub>	8V ≤ V <sub>IN</sub> ≤ 38V	0.190	0.200	0.210	V
Feedback Overvoltage Threshold	OVP <sub>(FB)</sub>		-	1.25X	-	V <sub>FB</sub>
High-Side Switch On Resistance (Note)	R <sub>DS(ON)1</sub>		-	150	-	mΩ
Low-Side Switch On Resistance (Note)	R <sub>DS(ON)2</sub>		-	140	-	mΩ
High-Side Switch Leakage Current		V <sub>EN</sub> = 0V, V <sub>SW</sub> = 0V	-	-	10	μA
Upper Switch Current Limit		Minimum Duty Cycle	2.9	3.5	-	A
Lower Switch Current Limit		From Drain to Source	-	0.7	-	A
Oscillation Frequency	F <sub>OSC1</sub>		-	240	-	KHz
Short Circuit Oscillation Frequency	F <sub>OSC2</sub>	V <sub>FB</sub> = < 0.5V	-	90	-	KHz
Maximum Duty Cycle	D <sub>MAX</sub>		-	90	-	%
Minimum On Time (Note)	T <sub>ON(min)</sub>		-	220	-	ns
EN Lockout Threshold Voltage	ENH <sub>(LOCK)</sub>		-	2.5	-	V
EN Lockout Hysteresis			-	210	-	mV
Input Under Voltage Lockout Threshold	UVLO	V <sub>IN</sub> Rising	6.5	7.0	7.5	V
Input Under Voltage Lockout Threshold Hysteresis	UVLO-Hys		-	800	-	mV
Input Over Voltage Lockout Threshold	OVLO	V <sub>IN</sub> Rising	-	40	-	V
Input Over Voltage Lockout Threshold Hysteresis	OVLO-Hys		-	5	-	V
Soft-Start Period			-	3	-	ms
Thermal Shutdown	T <sub>SD</sub>		-	150	-	°C
Thermal Shutdown Hysteresis	T <sub>SH</sub>		-	30	-	°C

Note: Guaranteed by design.

## ❖ FUNCTION DESCRIPTIONS

The MA5603 is a synchronous rectified, current-mode, step-down regulator. It regulates input voltages from 8V to 38V down to an output voltage as low as  $V_{FB}$ , and supplies up to 2.5A of load current.

The MA5603 uses current-mode control to regulate the output voltage. The output voltage is measured at FB through a resistive voltage divider and amplified through the internal Transconductance error amplifier. The voltage at the COMP pin is compared to the switch current measured internally to control the output voltage.

The converter uses internal N-Channel MOSFET switches to step-down the input voltage to the regulated output voltage. Since the high side MOSFET requires a gate voltage greater than the input voltage, a boost capacitor connected between SW and BS is needed to drive the high side gate. The boost capacitor is charged from the internal 5V rail when SW is low.

When the MA5603 FB pin exceeds 10% of the nominal regulation voltage of  $V_{FB}$ , the over voltage comparator is tripped and the COMP pin is discharged to GND, forcing the high-side switch off.

### Setting the LED Current

Application circuit item shows the basic application circuit with adjustable output version. The external resistor sets the output voltage according to the following equation:

$$I_{LED} = \left( \frac{V_{FB}}{R_{SET}} \right), V_{FB} = 0.2V$$

Table 1 Resistor select for LED output current setting

$I_{LED}$	RSET	
333mA	0.6Ω	67mW
666mA	0.3Ω	133mW
1000mA	0.2Ω	200mW

## ❖ PACKAGE OUTLINES

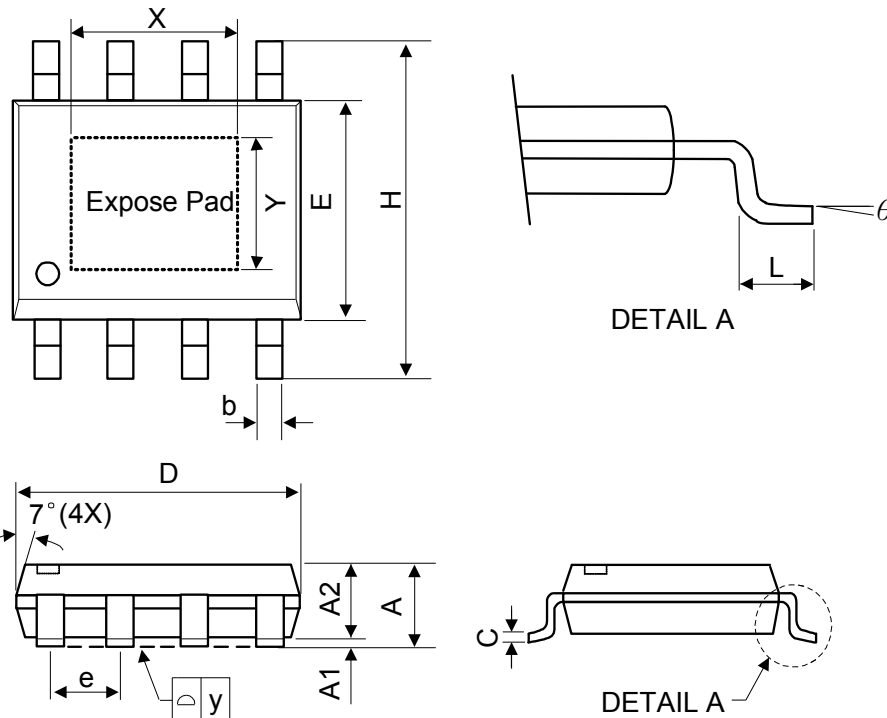

Symbol	Dimensions in Millimeters			Dimensions in Inches		
	Min.	Nom.	Max.	Min.	Nom.	Max.
A	-	-	1.75	-	-	0.069
A1	0	-	0.15	0	-	0.06
A2	1.25	-	-	0.049	-	-
C	0.1	0.2	0.25	0.0075	0.008	0.01
D	4.7	4.9	5.1	0.185	0.193	0.2
E	3.7	3.9	4.1	0.146	0.154	0.161
H	5.8	6	6.2	0.228	0.236	0.244
L	0.4	-	1.27	0.015	-	0.05
b	0.31	0.41	0.51	0.012	0.016	0.02
e	1.27 BSC			0.050 BSC		
y	-	-	0.1	-	-	0.004
X	-	2.34	3.33	-	0.092	0.131
Y	-	2.34	2.54	-	0.092	0.10
θ	0°	-	8°	0°	-	8°

- ❖ Mold flash shall not exceed 0.25mm per side
- ❖ JEDEC outline: MS-012 BA