

# MA6221-S7K

## RF Optical Mouse Controller

---

---

**Preliminary Spec 1.0**

# MosArt

SEMICONDUCTOR CORP.

2002 All rights reserved

**Content**

<b>1. General Description.....</b>	<b>1</b>
<b>2. Features .....</b>	<b>1</b>
<b>3. Block Diagram.....</b>	<b>2</b>
<b>4. Pin Out &amp; Description.....</b>	<b>3</b>
<b>5 Optical sensor power saving.....</b>	<b>5</b>
<b>6 Package Type .....</b>	<b>5</b>
<b>7 Application circuit .....</b>	<b>6</b>

www.DataSheet4U.com

## ***1. General Description***

The MA60H22 is an encoder IC that can encode the data from the mouse optical sensor and sends these data via RF at 27 MHz. The MA60H22 is equipped with a complete set of FSK modulator that also provides single/dual RF channel solution. This will reduce the extra external component for RF interface. The two kinds of output from mouse optical sensor, namely quadrature and SPI (serial peripheral interface) are supported. Furthermore, the MA60H22 has a DC/DC embedded. It can work with MOSART MA606 (mouse U+P receiver controller) to be a pair of RF mouse. Or it can work with MOSART MA60H13 (keyboard + mouse PS/2 receiver controller) to be a pair of RF keyboard + mouse solution.

## ***2. Features***

- 76.8KHz clock rate (low power consumption)
- Hi speed & 32.768KHz OSC supported (optional)
- Build-in data scrambler and error detection encoder
- Build-in single/dual channel RF oscillator, modulator and power amplifier
- 4k bps Baud rate in air.
- ID change solution (256 random IDs) to resist the interference from the same device
- 3V or 5V DC/DC embedded
- Battery low detection
- ID retention function when battery removed.
- X/Y axis support for both quadrature and SPI(serial peripheral interface) input
- Z axis supports for optical and mechanical inputs (Z/2,Z/4 can also be selected)
- Support Agilent 2000, 2030, 2051, 2610 and 2620 optical sensors.
- Support all kinds of Pixart sensors (PAN101, PAN201)

### 3. Block Diagram

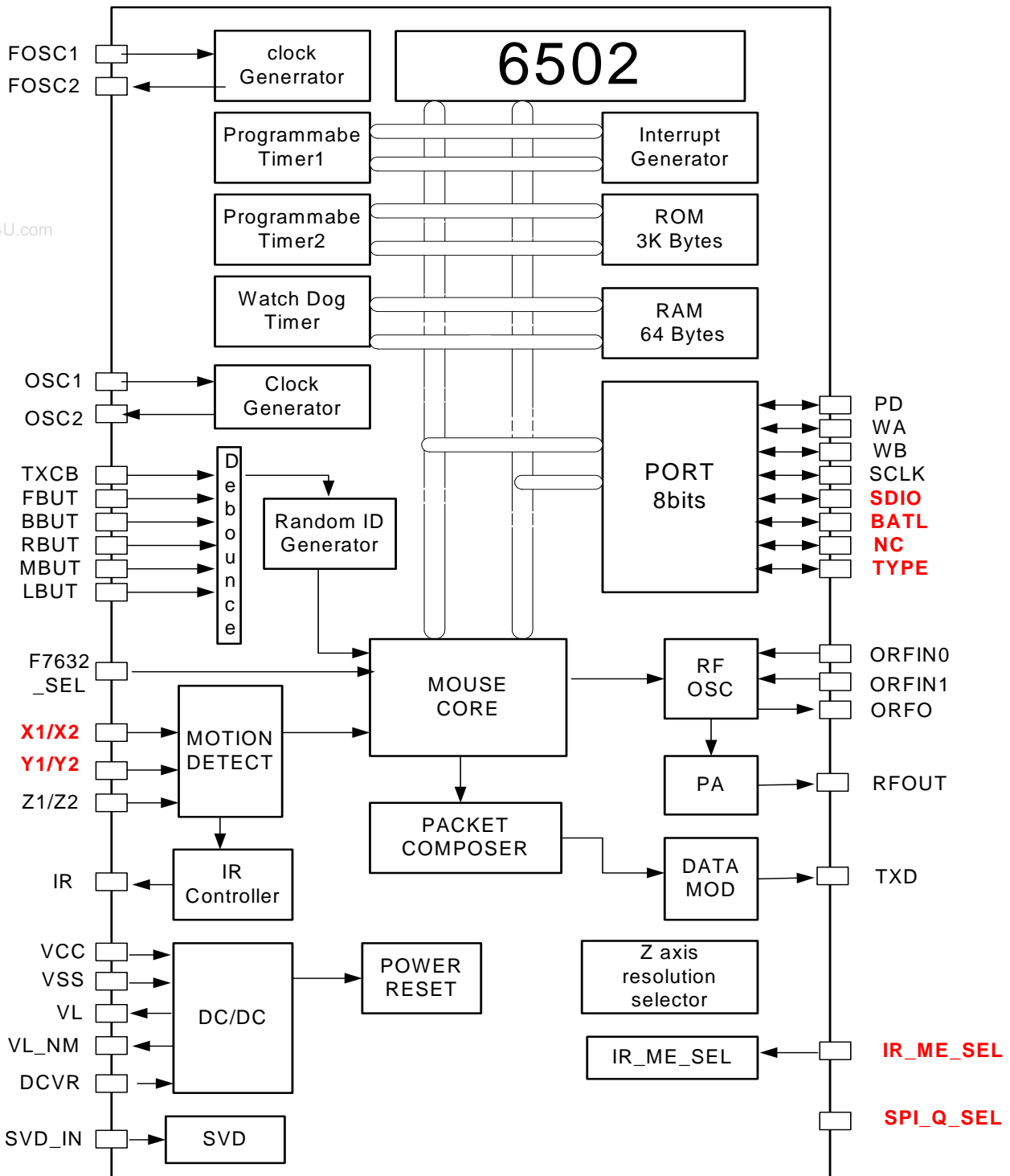

### 4. Pin Out & Description

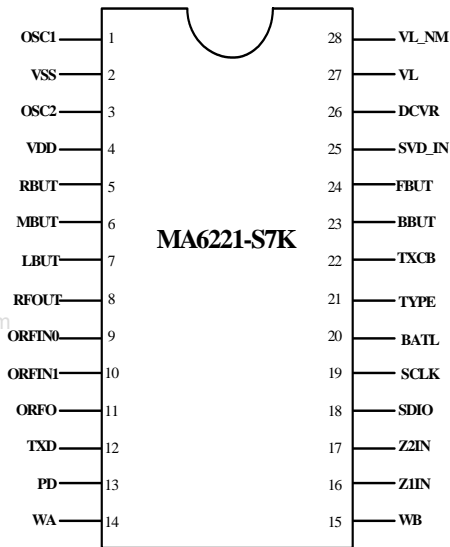

SOP28

PIN No.	Symbol	I/O	Description
1	OSC1	I	Oscillator Input
2	VSS	P	Ground
3	OSC2	O	Oscillator Output
4	VDD	P	Power
5	RBUT	I	Right Button
6	MBUT	I	Middle Button
7	LBUT	I	Left Button
8	RFOUT	O	Internal Modulated RF Output
9	ORFIN0	I	RF Internal Buffer Input Set 0 (27MHZ Oscillator Input)
10	ORFIN1	I	RF Internal Buffer Input Set 1 (27MHZ Oscillator Input)
11	ORFO	O	RF Internal Buffer Output (27MHZ Oscillator Input)
12	TXD	O	Digital Encoded Data
13	PD	I/O	Control power down signal of optical sensor
14	WA	I/O	Wakeup point A
15	WB	I/O	Wakeup Point B
16	Z1IN	I	Z Axis Input (3D)
17	Z2IN	I	Z Axis Input (3D)
18	SDIO	I/O	Control serial data signal of optical sensor
19	SCLK	I/O	Control serial clock signal of optical sensor
20	BATL	I/O	Battery Low display
21	TYPE	I/O	Control serial degree of optical sensor
22	TXCB	I	ID Change Button
23	BBUT	I	Backward Button
24	FBUT	I	Forward Button
25	SVDIN	I	Supply Voltage Detect Input
26	DCVR	I	DC/DC Voltage Reference
27	VL	O	DC/DC Lx Switch output
28	VL_NM	O	DC/DC Lx Switch output without MOS

### 5 Optical sensor power saving.

Step1. Sensor is in charge of the power control

Step2. Controller takes charge of the control for 8 mins.

Step3. Power down completely. Power-up mode is activated by any one of the keys or scroll bar.

PD timing of step2.

Sensor Type	PD control method	Time
ADNS2000	PD always low	8 mins
ADNS2030	PD High 11ms, low 4.5ms	8 mins
ADNS2051	PD High 11ms, low 4.5ms	8 mins
ADNS2610	PD always low	8 mins
ADNS2620	PD always low	8 mins
PAN101	PD always low	8 mins

Note that PD is active low.

### 6 Package Type

28pin/SOP/Body: 300mil/Pitch: 1.27mm

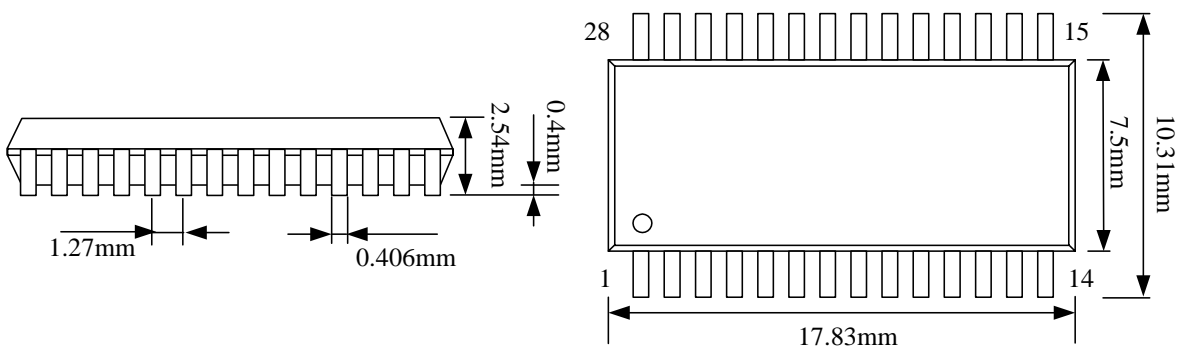

## 7 Application circuit

