

Voltage Variable Attenuator 5 - 45 GHz

Rev. V4

Features

- 5 - 45 GHz frequency range
- 2 dB typical insertion loss
- >30 dB attenuation range
- High linearity, 30 dBm IIP3
- Lead-Free 3 mm, 16-Lead QFN Package
- RoHS* Compliant

Description

The MAAT-010521 is a voltage variable attenuator with analog control and up to 40 dB of attenuation. Excellent linearity is maintained over the full attenuation range. The attenuation level is set by two control voltages of 0 to -2V.

The 3mm QFN package is RoHS compliant and compatible with reflow temperatures to 260°C. Applications include transceivers for cellular infrastructure.

Functional Block Diagram

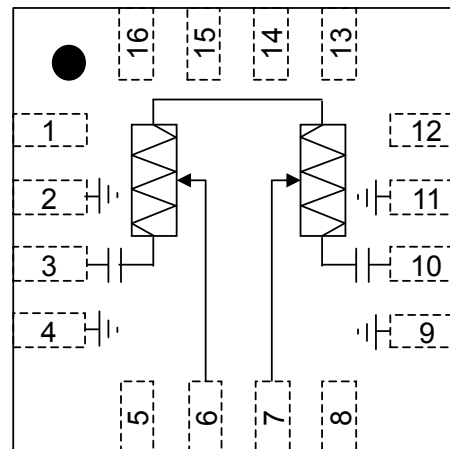

Pin Configuration^{3,4}

Pin No.	Function
1	No Connection
2	Ground
3	RF Input
4	Ground
5	No Connection
6	VC1
7	VC2
8	No Connection
9	Ground
10	RF Output
11	Ground
12	No Connection
13	No Connection
14	No Connection
15	No Connection
16	No Connection

Ordering Information^{1,2}

Part Number	Package
MAAT-010521-TR0500	500 piece reel
MAAT-010521-TR3000	3000 piece reel
MAAT-010521-001SMB	Sample Test Board

1. Reference Application Note M513 for reel size information.
2. All sample boards include 5 loose parts.

* Restrictions on Hazardous Substances, European Union Directive 2011/65/EU.

3. It is recommended to connect unused pins to ground.
4. The exposed pad centered on the package bottom must be connected to RF, DC and thermal ground.

Voltage Variable Attenuator 5 - 45 GHz

Rev. V4

Electrical Specifications: $T_A = +25^\circ\text{C}$, $Z_0 = 50 \Omega$, $P_{IN} = -10 \text{ dBm}$

Parameter	Test Conditions	Units	Min.	Typ.	Max.
Insertion Loss (V_{c1} and $V_{c2} = -2.0\text{V}$)	5 - 10 GHz	dB	—	2	4
	10 - 20 GHz			2	4
	20 - 40 GHz			3	6
Attenuation (V_{c1} and $V_{c2} = 0\text{V}$) ⁵	5 - 10 GHz	dB	24	30	—
	10 - 20 GHz		31	40	
	20 - 40 GHz		34	40	
Input P1dB	5 GHz to 25 GHz	dBm	24	25	—
	25 GHz to 40 GHz		20	22	
IIP3 (any attenuation)	$P_{IN} = 12 \text{ dBm/tone @ } 5.0 - 15.0 \text{ GHz}$	dBm	29	31	—
	$P_{IN} = 12 \text{ dBm/tone @ } 15.0 - 26.5 \text{ GHz}$		28	30	
	$P_{IN} = 12 \text{ dBm/tone @ } 26.5 - 40.0 \text{ GHz}$		25	28	
IIP3 ($V_{c1}=V_{c2}=-2.0\text{V}$)	$P_{IN} = 12 \text{ dBm/tone @ } 5 - 40 \text{ GHz}$	dBm	35	40	—
Input Return Loss (any attenuation)	—	dB	—	10	—
Output Return Loss (any attenuation)	—	dB	—	10	—

5. To increase attenuation from minimum attenuation state ($V_{C1} = -2 \text{ V}$ and $V_{C2} = -2 \text{ V}$) to max attenuation state ($V_{C1} = 0 \text{ V}$ and $V_{C2} = 0 \text{ V}$), V_{C1} increases to full range prior to adjusting V_{C2} .

Absolute Maximum Ratings^{6,7}

Parameter	Absolute Maximum
Input Power	+30 dBm
Voltage (RF pins)	30 V
Voltage (control pins)	+1 to -6 V
Storage Temperature	-55°C to +150°C
Case Temperature	-40°C to +85°C

5. Exceeding any one or combination of these limits may cause permanent damage to this device.
6. MACOM does not recommend sustained operation near these survivability limits.

Handling Procedures

The following precautions should be observed to avoid damage:

Static Sensitivity

Gallium Arsenide Integrated Circuits are sensitive to electrostatic discharge (ESD) and can be damaged by static electricity. Proper ESD control techniques should be used when handling these class 1C (HBM) devices.

Typical Performance Curves: S-Parameters

Gain

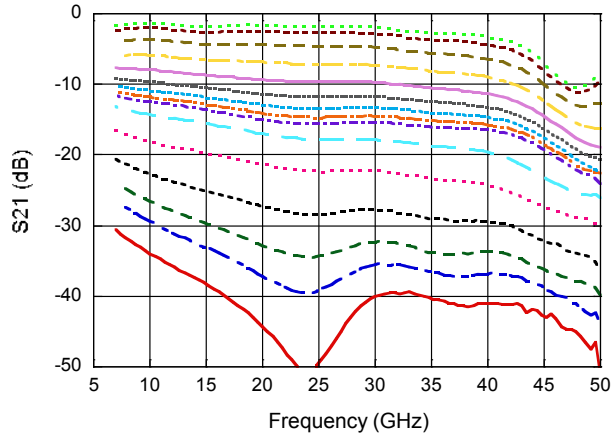

Input Return Loss

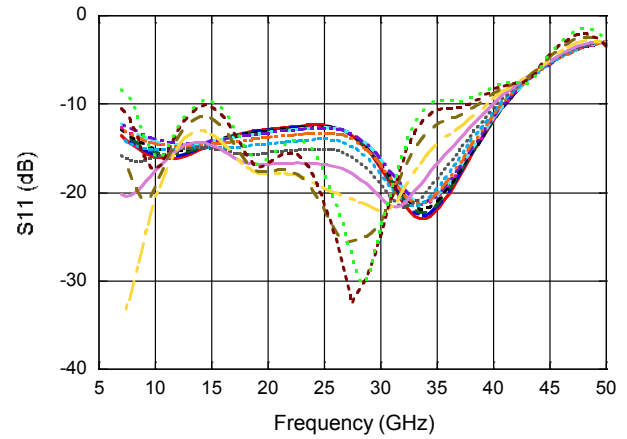

Output Return Loss

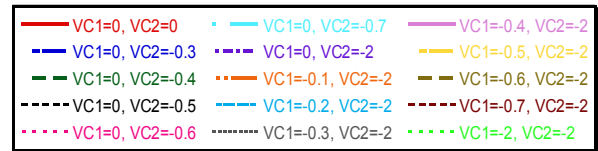
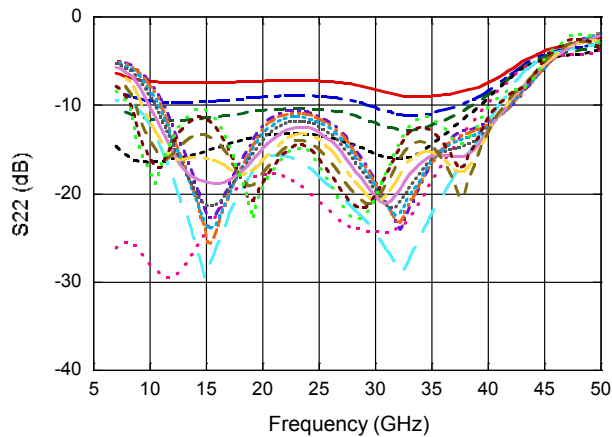

Typical Performance Curves: S-Parameters

VC1 = -2, VC2 = -2

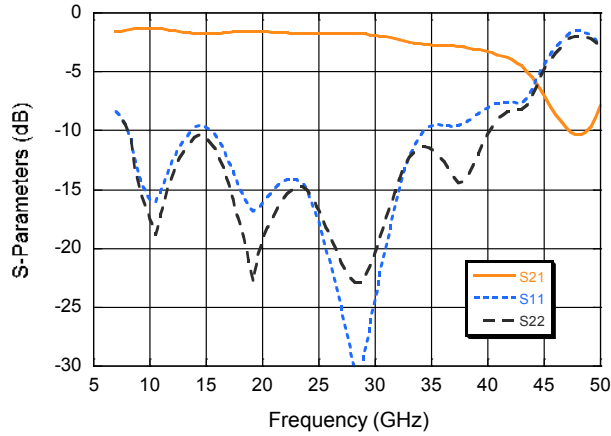

VC1 = -0.6, VC2 = -2

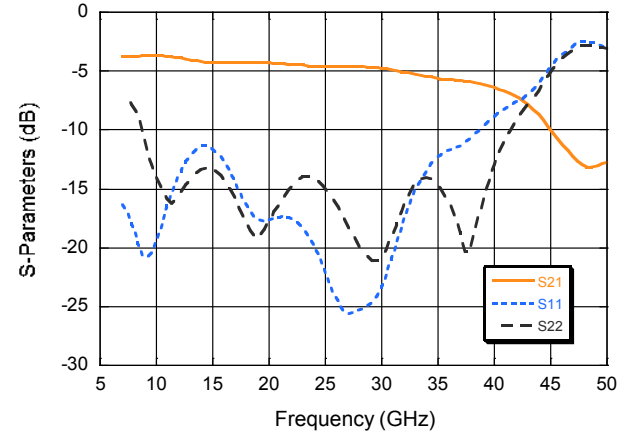

VC1 = -0.4, VC2 = -2

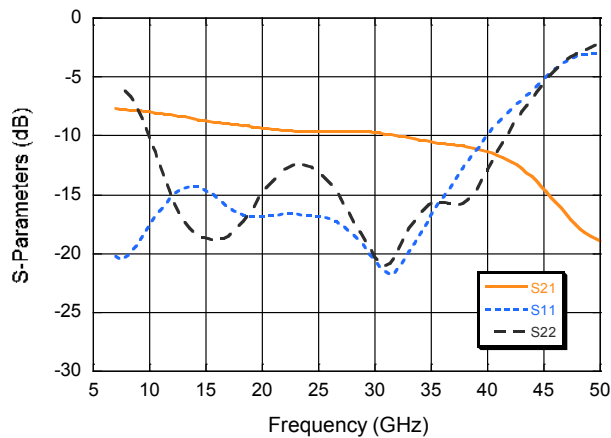

VC1 = -0.1, VC2 = -2

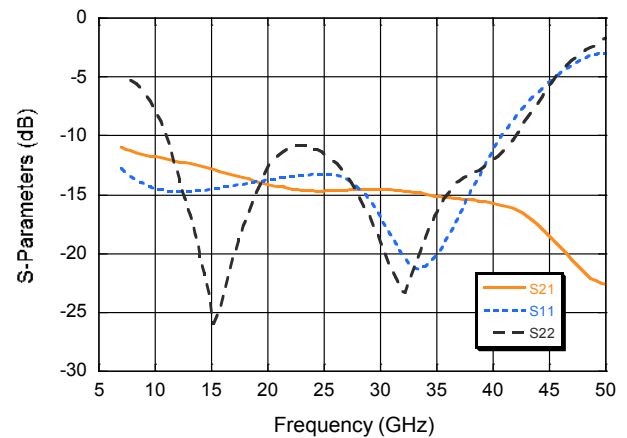

VC1 = 0, VC2 = -0.6

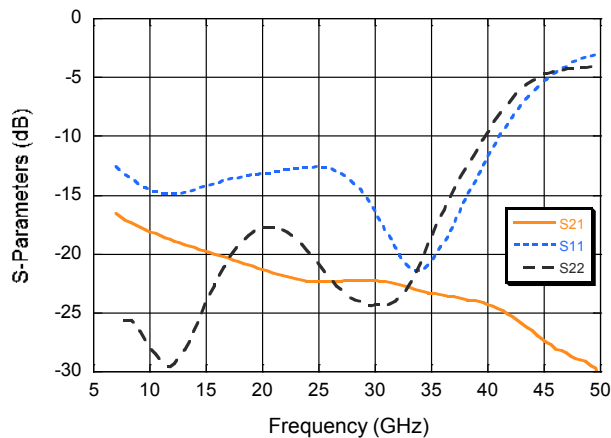

Typical Performance Curves: Gain

Gain vs. P_{IN} ($VC1 = -2, VC2 = -2$) @ 15 GHz

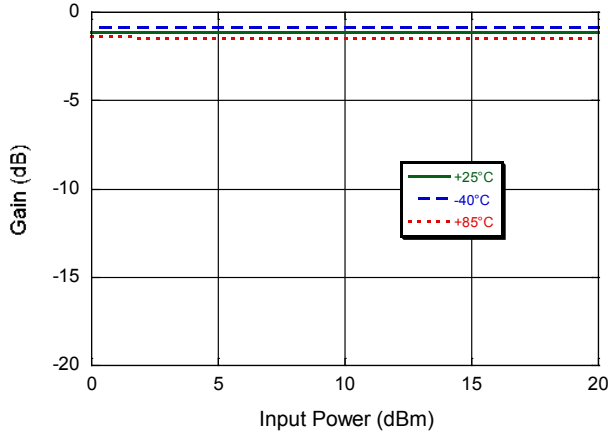

Gain vs. P_{IN} ($VC1 = -2, VC2 = -2$)

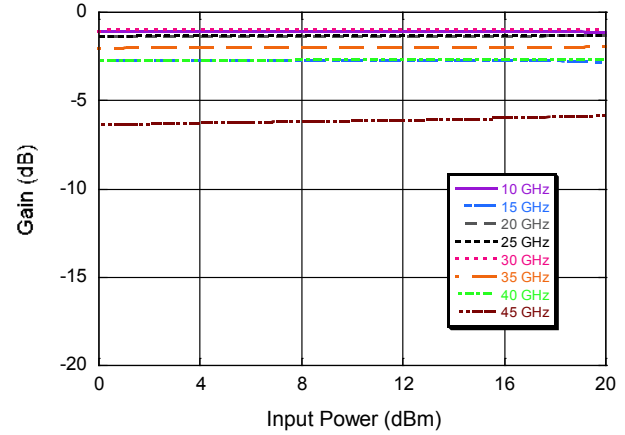

Gain vs. P_{IN} ($VC1 = -0.4, VC2 = -2$) @ 15 GHz

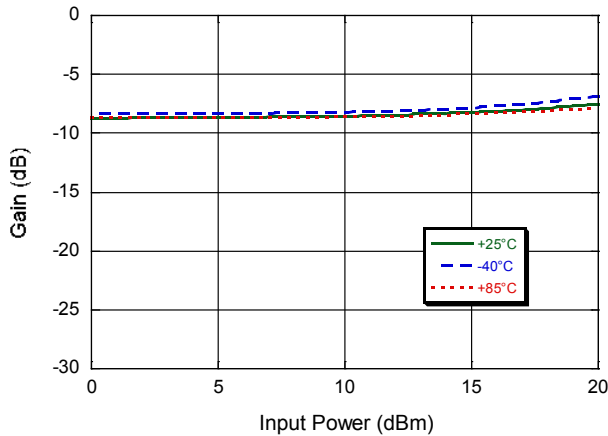

Gain vs. P_{IN} ($VC1 = -0.4, VC2 = -2$)

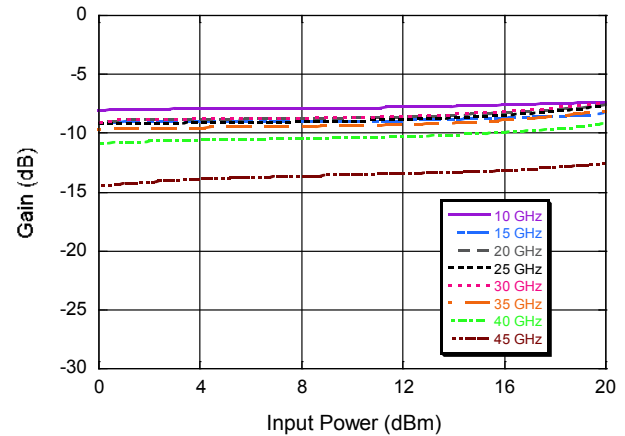

Gain vs. P_{IN} ($VC1 = 0, VC2 = -0.6$) @ 25°C

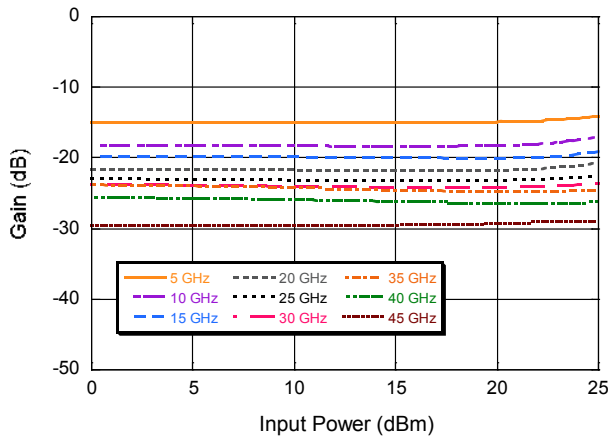

Gain vs. P_{IN} ($VC1 = 0, VC2 = 0$) @ 25°C

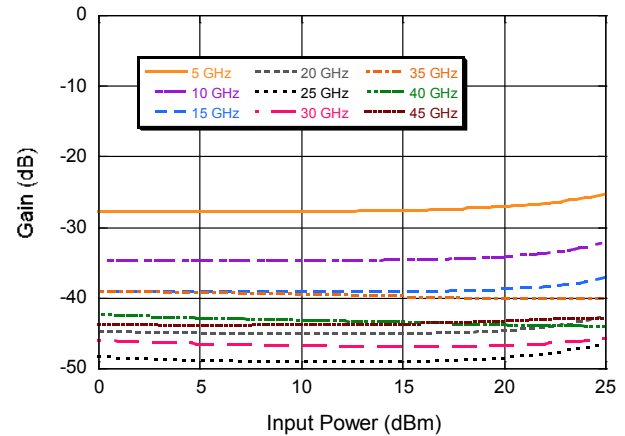

Voltage Variable Attenuator 5 - 45 GHz

Rev. V4

Typical Performance Curves: Input IP3

Input IP3 (VC1 = -2, VC2 = -2)

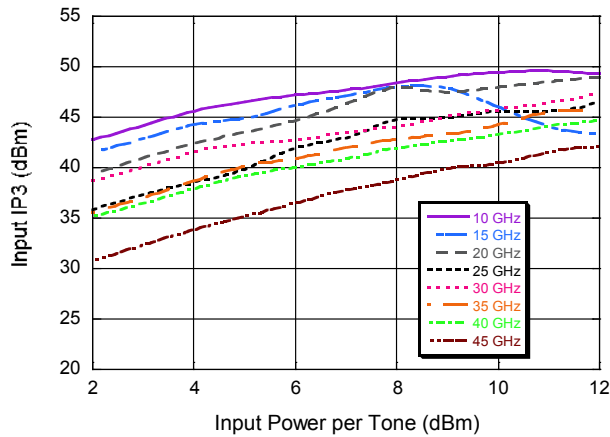

Input IP3 (P_{IN} per tone = 12 dBm)

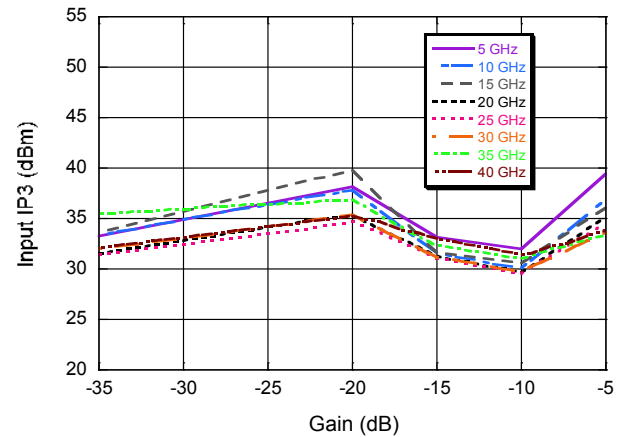

Lead-Free 3 mm 16-Lead PQFN[†]

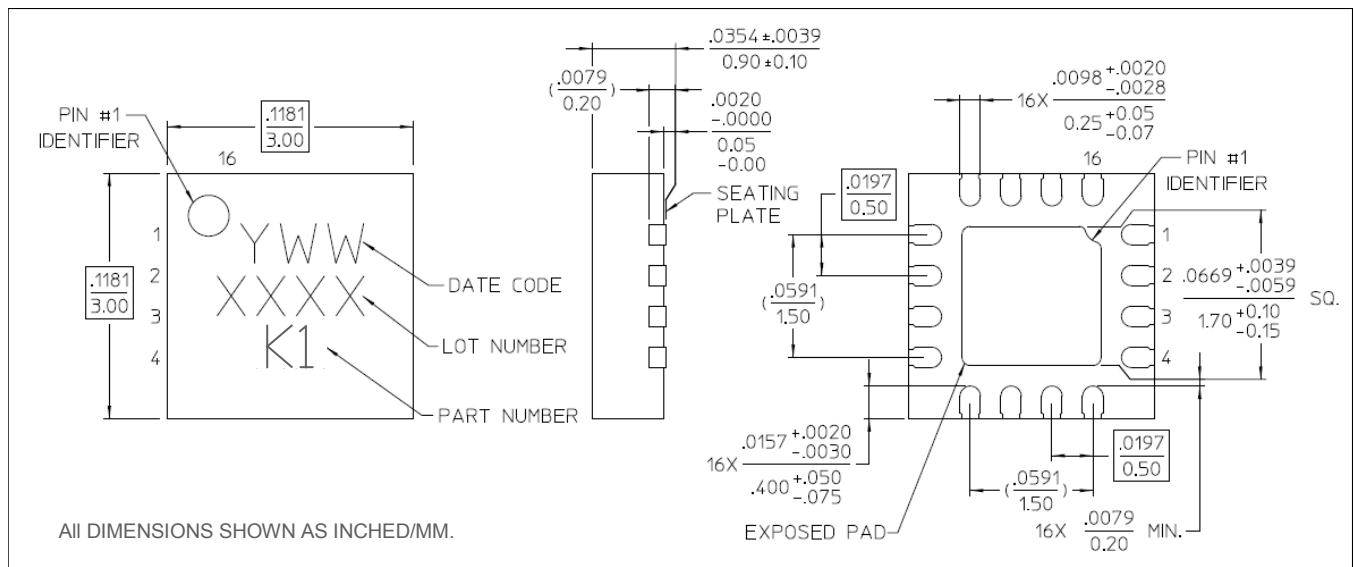

[†] Reference Application Note S2083 for lead-free solder reflow recommendations.
Meets JEDEC moisture sensitivity level 1 requirements.
Plating is NiPdAuAg.

M/A-COM Technology Solutions Inc. All rights reserved.

Information in this document is provided in connection with M/A-COM Technology Solutions Inc ("MACOM") products. These materials are provided by MACOM as a service to its customers and may be used for informational purposes only. Except as provided in MACOM's Terms and Conditions of Sale for such products or in any separate agreement related to this document, MACOM assumes no liability whatsoever. MACOM assumes no responsibility for errors or omissions in these materials. MACOM may make changes to specifications and product descriptions at any time, without notice. MACOM makes no commitment to update the information and shall have no responsibility whatsoever for conflicts or incompatibilities arising from future changes to its specifications and product descriptions. No license, express or implied, by estoppel or otherwise, to any intellectual property rights is granted by this document.

THESE MATERIALS ARE PROVIDED "AS IS" WITHOUT WARRANTY OF ANY KIND, EITHER EXPRESS OR IMPLIED, RELATING TO SALE AND/OR USE OF MACOM PRODUCTS INCLUDING LIABILITY OR WARRANTIES RELATING TO FITNESS FOR A PARTICULAR PURPOSE, CONSEQUENTIAL OR INCIDENTAL DAMAGES, MERCHANTABILITY, OR INFRINGEMENT OF ANY PATENT, COPYRIGHT OR OTHER INTELLECTUAL PROPERTY RIGHT. MACOM FURTHER DOES NOT WARRANT THE ACCURACY OR COMPLETENESS OF THE INFORMATION, TEXT, GRAPHICS OR OTHER ITEMS CONTAINED WITHIN THESE MATERIALS. MACOM SHALL NOT BE LIABLE FOR ANY SPECIAL, INDIRECT, INCIDENTAL, OR CONSEQUENTIAL DAMAGES, INCLUDING WITHOUT LIMITATION, LOST REVENUES OR LOST PROFITS, WHICH MAY RESULT FROM THE USE OF THESE MATERIALS.

MACOM products are not intended for use in medical, lifesaving or life sustaining applications. MACOM customers using or selling MACOM products for use in such applications do so at their own risk and agree to fully indemnify MACOM for any damages resulting from such improper use or sale.