

**2:1 Flux Coupled Transformer  
5-200MHz**

**MABACT0068  
V1P**

**Features**

- Surface Mount
- 2:1 Impedance
- Excellent amplitude and phase balance
- 260°C Reflow Compatible
- RoHS\* Compliant
- Available on Tape and Reel. Reel quantity 2000

**Description**

M/A-COM's MABACT0068 is a 2:1 RF Flux Coupled balun transformer in a low cost, surface mount package. Ideally suited for high volume CATV/ Broadband applications. Suitable for use in 50 and 75 Ohm systems.

**Schematic**

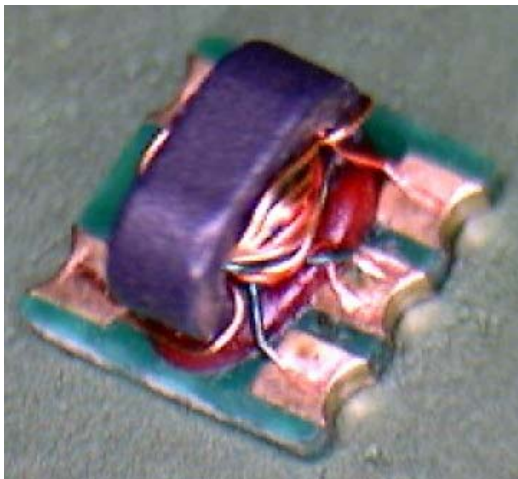
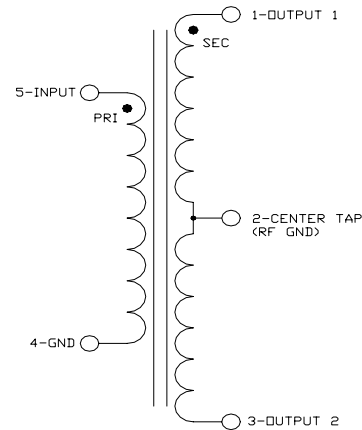

**Case Style: SM-164**

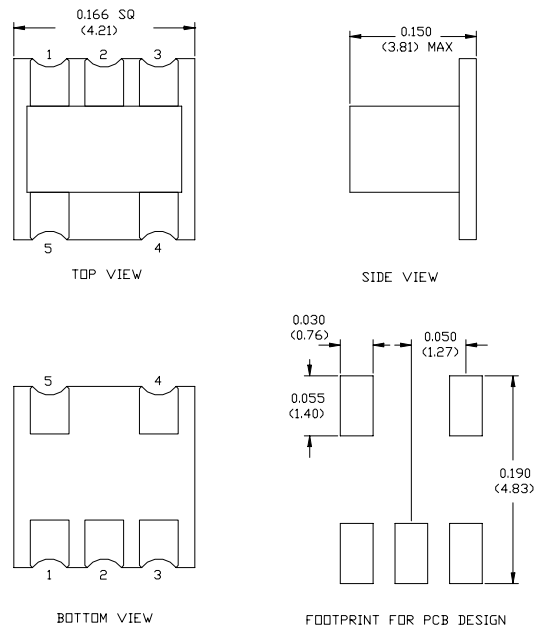

Dimensions in inches [mm] Tolerance: .xx ± .02, .xxx ± .010

**Pin Configuration**

Pin No.	Function
1	Secondary Dot (output 1)
2	Centre Tap (ground)
3	Secondary (output 2)
4	Primary (Ground)
5	Primary Dot (Input)

Note: Reference Application Note **M513** for reel size information.

**Ordering Information**

Part Number	Package
MABACT0068TR	2000 piece reel

\* Restrictions on Hazardous Substances, European Union Directive 2002/95/EC.

**2:1 Flux Coupled Transformer  
5-200MHz**

**MABACT0068  
V1P**

**Electrical Specifications:  $T_A = 25^\circ\text{C}$ ,  $Z_0 = 75\Omega$**

Parameter	Test Conditions	Units	Min	Typ	Max
Insertion Loss	5 - 65 MHz	dB	-	0.3	0.5
Insertion Loss	65 - 200 MHz	dB	-	0.4	0.9
Amplitude Unbalance (Nominal 0dB)	5 - 65 MHz	dB	-	$\pm 0.02$	$\pm 0.15$
Phase Unbalance (Nominal 180°)	5 - 50 MHz	°	-	$\pm 0.00$	$\pm 2.00$
Input Return Loss	5 - 200 MHz	dB	18	22	-

**Absolute Maximum Ratings <sup>1,2</sup>**

Parameter	Absolute Maximum
Max Input Power	250mW
DC current	240mA
Operating Temperature	-40°C to +85°C
Storage Temperature	-55°C to +100°C

- Exceeding any one or combination of these limits may cause permanent damage to this device.
- M/A-COM does not recommend sustained operation near these survivability limits.

**Recommended PCB Configuration**

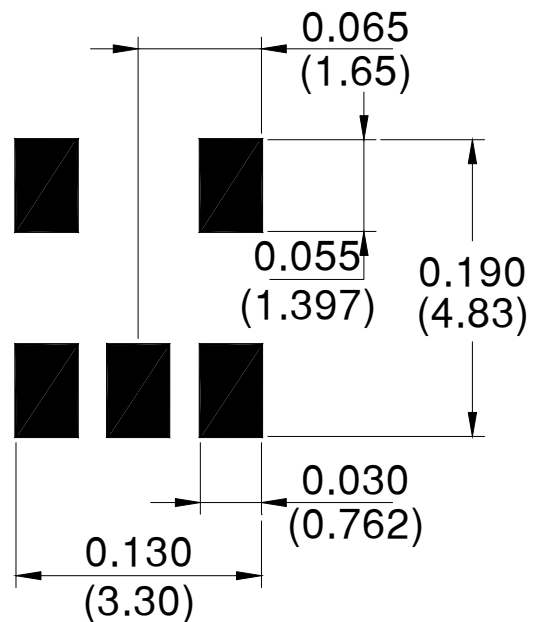

**2:1 Flux Coupled Transformer  
5-200MHz**

**MABACT0068  
V1P**

**Typical Performance Curves:  $T_A = 25^\circ\text{C}$ ,  $Z_0 = 75\Omega$**

**Insertion Loss 1 (through pin 5 to pin 1)**

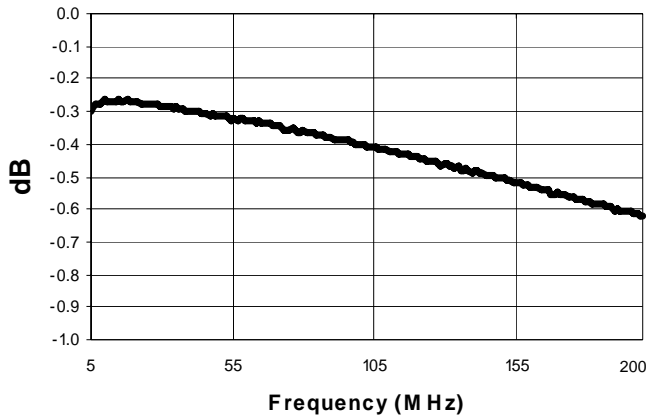

**Insertion Loss 2 (coupled pin 5 to pin 3)**

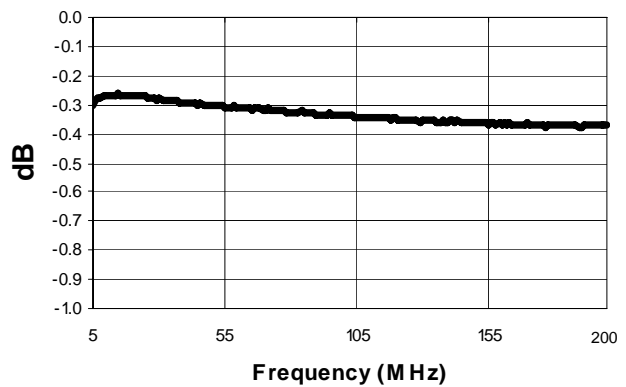

**Amplitude Unbalance**

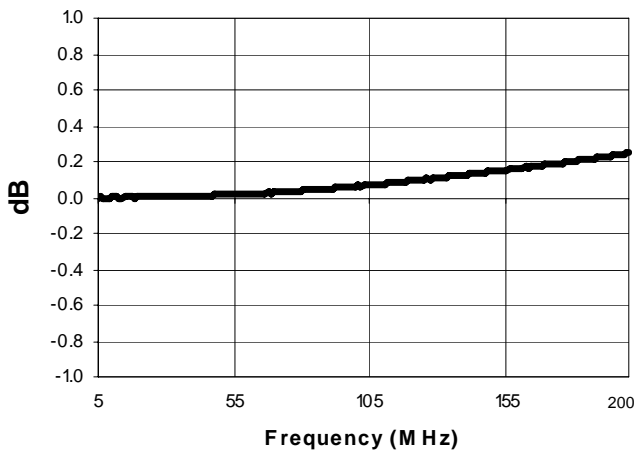

**Phase Balance**

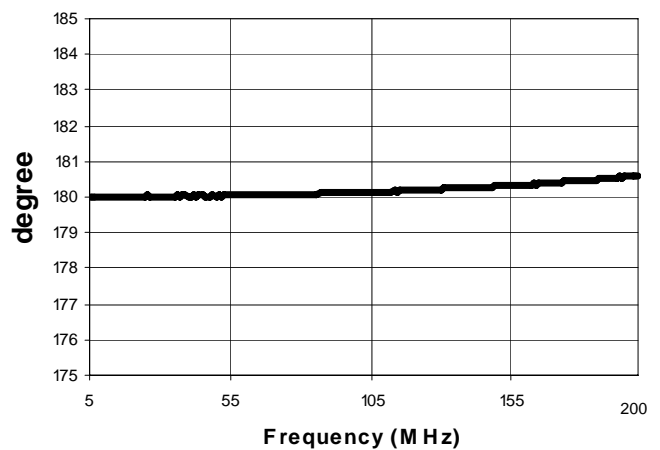

**Input Return Loss**

