

**Released**

# X-band Magnetron

## Model No. MAF1615B

### Copyright©

**Nisshinbo Micro Devices Inc.**  
**Microwave Business Headquarters**

-Notice of Proprietary Information-

This document and its contents are proprietary to Nisshinbo Micro Devices Inc.  
This publication and its contents may not be reproduced or distributed for any other purpose  
without the written permission of Nisshinbo Micro Devices Inc.  
Those specifications listed in this document are subject to change at any time.

## ■ GENERAL DESCRIPTION

MAF1615B is designed for the magnetron of X-band radar system. The frequency range is fixed <9380 - 9440MHz> and the peak output power is 12kW.

**【V9 Technology】**



## ■ ELECTRICAL CHARACTERISTICS

PARAMETERS	MINIMUM	TYPICAL	MAXIMUM	UNITS
Heater voltage				
at stand by	7.5	8.0	8.5	V
at operation (note 1)	6.0	6.3	6.6	V
Preheat time	65	-	-	s
Peak anode voltage (note 2)	5.4	5.8	6.0	kV
Peak output power (note 2)	12.0	12.5		kW
Frequency (note 2)	9380	9410	9440	MHz

## ■ ABSOLUTE MAXIMUM RATINGS

These ratings cannot necessarily be used simultaneously and no individual ratings should be exceeded.

PARAMETERS	MINIMUM	MAXIMUM	UNITS
Peak anode current (note 3)	4.6	6.8	A
Average anode power input	-	40	W
Duty cycle	-	0.001	-
Pulse duration	0.07	1.25	μs
Rate of rise of voltage pulse	-	80	kV/μs
Anode temperature	-	120	°C
VSWR at the output coupler	-	1.5 : 1	-

### Notes

1. Measured with heater voltage of 8.0V the heater current limits are 0.62A minimum, 0.68A maximum and with heater voltage 6.3V the heater current limits are 0.52A minimum, 0.58A maximum.Reduction of heater voltage at operating is required.
2. Measured at peak anode current 5.8.

\* Above Specifications are subject to change without notice.

- Any overshoot of the anode current is not acceptable. The impedance of this magnetron is the same as current magnetron excluding the transient impedance. This means that the additional reactance should be required for adjustment the anode current wave form, if this magnetron will be installed into the similar modulator circuit as before.

## ■ OUTLINE

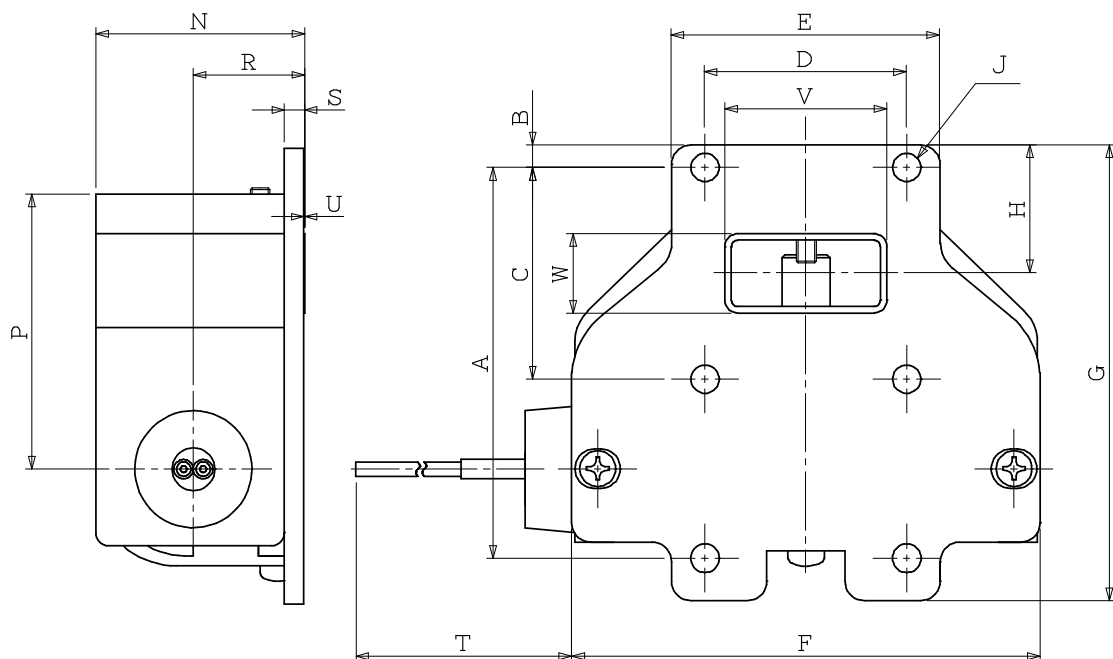

Anode temperature measured at this point

A	60±0.2	L	9
B	3.75	M	7
C	32.5 ±0.1	N	33MAX
D	31±0.1	P	43
E	41.3	R	17
F	72	S	3
G	70	T	185±10
H	20	U	0.1±0.05
J	4-φ4.32 ±0.08	V	24.9±0.2
K	2-φ4.4 ±0.1	W	12.2±0.2

### Lead Connections

Colour	Element
Green	Heater
Yellow	Heater, Cathode

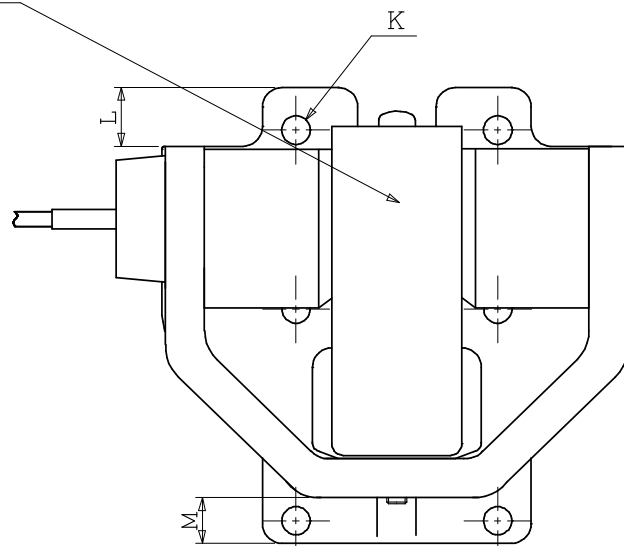

Top View

(Dimensions are expressed in "mm".)

\* Above Specifications are subject to change without notice.

