

# WASHER

## Repair Parts List

MODEL NUMBER  
MAH21PNDWW

When requesting service or ordering parts, always provide the following information:

- Product Type
- Part Number
- Model Number
- Part Description

**MAYTAG**®

©2005 Maytag Services

Section: CONTROL PANEL

Model: MAH21PNDWW

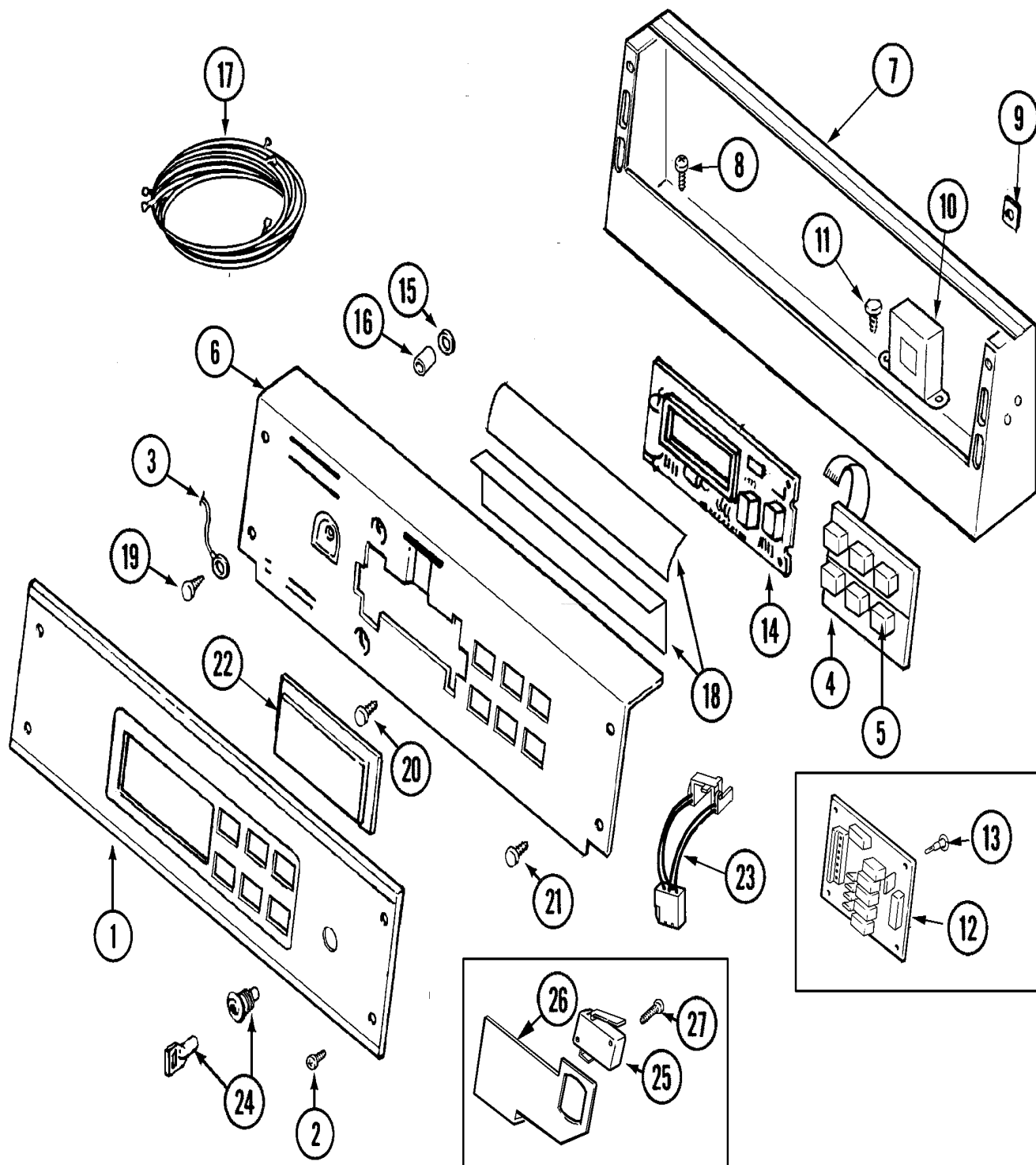

CW11-52

## Section: CONTROL PANEL

No.	Part No.	Description	Series	Qty
1	22004350	Facia - PN (CONTROL PANEL)	10	1
2	215506	SCREW, TORX Note: SCREW, CONTROL PANEL	10	4
3	205810	WIRE, GROUND	10	1
4	206808	CONTROL SWITCH ASSY. Note: CONTROL SWITCH ASSEMBLY	10	1
-	215527	SCREW Note: SCREW, CONTROL SWITCH	10	2
5	33002863	BUTTON, PUSH Note: PUSHBUTTON, CONTROL SWITCH	10	2
6	22003697	BRACKET, BACK (WHT)	10	1
7	22003101	CONSOLE (WHT)	10	1
8	22002925	SCREW	10	5
9	215003	FASTENER	10	2
10	22001960	TRANSFORMER	10	1
11	22002925	SCREW	10	2
11	22001419	NUT (ELASTIC) Note: NUT, TRANSFORMER	10	2
12	22004171	RELAY BOARD OPL	10	1
13	22002943	STAND-OFF	10	4
14	22003700	CONTROL BOARD	10	1
15	912077	LOCKNUT Note: LOCKNUT, CONTROL BOARD	10	6
16	33001204	STANDOFF, CIRCUIT BOARD	10	4
17	Y2205141	HARNESS, WIRE	23	1
17	22004052	HARNESS UPPER SUB ASSY	10	1
17	Y2205141	HARNESS, WIRE	22	1
17	22003934	WIRE HARNESS (MAIN)	10	1
18	22002954	DEFLECTOR, WATER (W/ADHESIVE)	10	1
19	211252	SCREW Note: SCREW, GROUND WIRE	10	1
20	215526	SCREW Note: SCREW, CIRCUIT BOARD	10	2
21	215527	SCREW Note: SCREW, BACK BRACKET	10	2
22	22001962	COVER, DISPLAY	10	1
23	33002090	HARNESS, SERVICE	10	1
24	Y206081	LOCK FOR ACCESS DOOR Note: LOCK	10	1
-	213750	LOCKING CAM Note: LOCKING TAB (CAM)	10	1
25	22002367	SWITCH, SENSOR	10	1
26	33001982	BRACKET, SWITCH MOUNTING	10	1
27	22002368	SCREW----NA Note: SCREW, SWITCH	10	1

\*Color Code (-)=Not Shown #=Series, Serial Prefix or Run No., N=Not Available

Section: TOP

Model: MAH21PNDWW

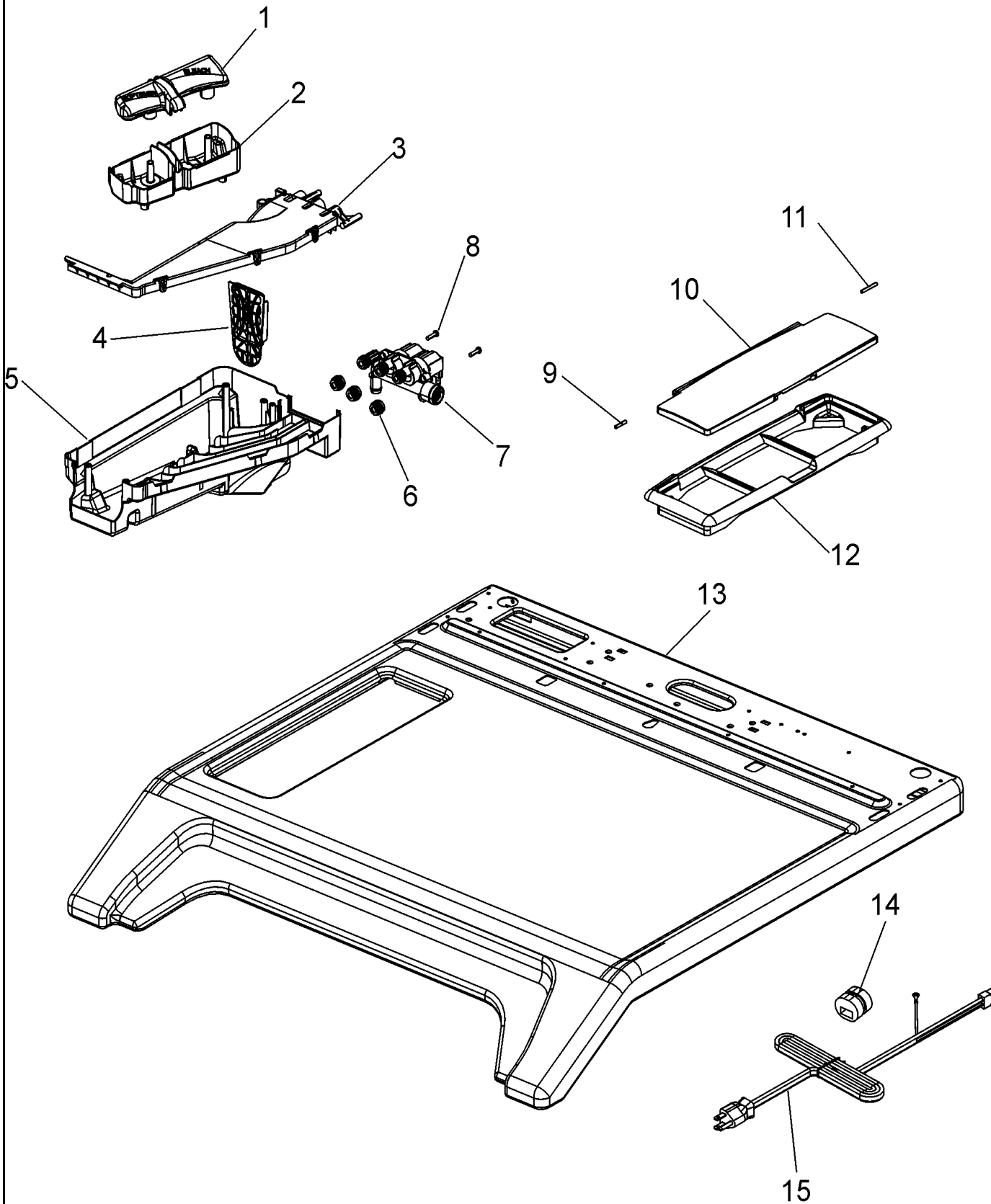

CW13-23

## Section: TOP

No.	Part No.	Description	Series	Qty
1	22003849	SIPHON CAP	10	1
2	22003848	SIPHON CUP	10	1
3	22003845	DISPENSER COVER (FLUME)	10	1
4	22003321	GRID, DISPENSER	10	1
5	22003844	DISPENSER BOTTOM	10	1
6	22003847	VALVE SEAL	10	3
7	22003846	DISPENSER VALVE	10	1
- N	22003835	DISPENSER ASSEMBLY	10	1
8	22002243	SCREW	10	2
9	Y912679	PIN, HINGE (SHORT)	10	1
10	22002941	LID, DISPENSER	10	1
11	Y912678	PIN, HINGE (LONG)	10	1
12	22003665	BEZEL, DISPENSER	10	1
13	22004180	COVER, TOP (WHT-AS PK)	10	1
14	211881	GROMMET, CORD	10	2
15	22003062	CORD, POWER (AS WRAPPED)	10	1

\*Color Code (-)=Not Shown #=Series, Serial Prefix or Run No., N=Not Available

Section: CABINET-FRONT

Model: MAH21PNDWW

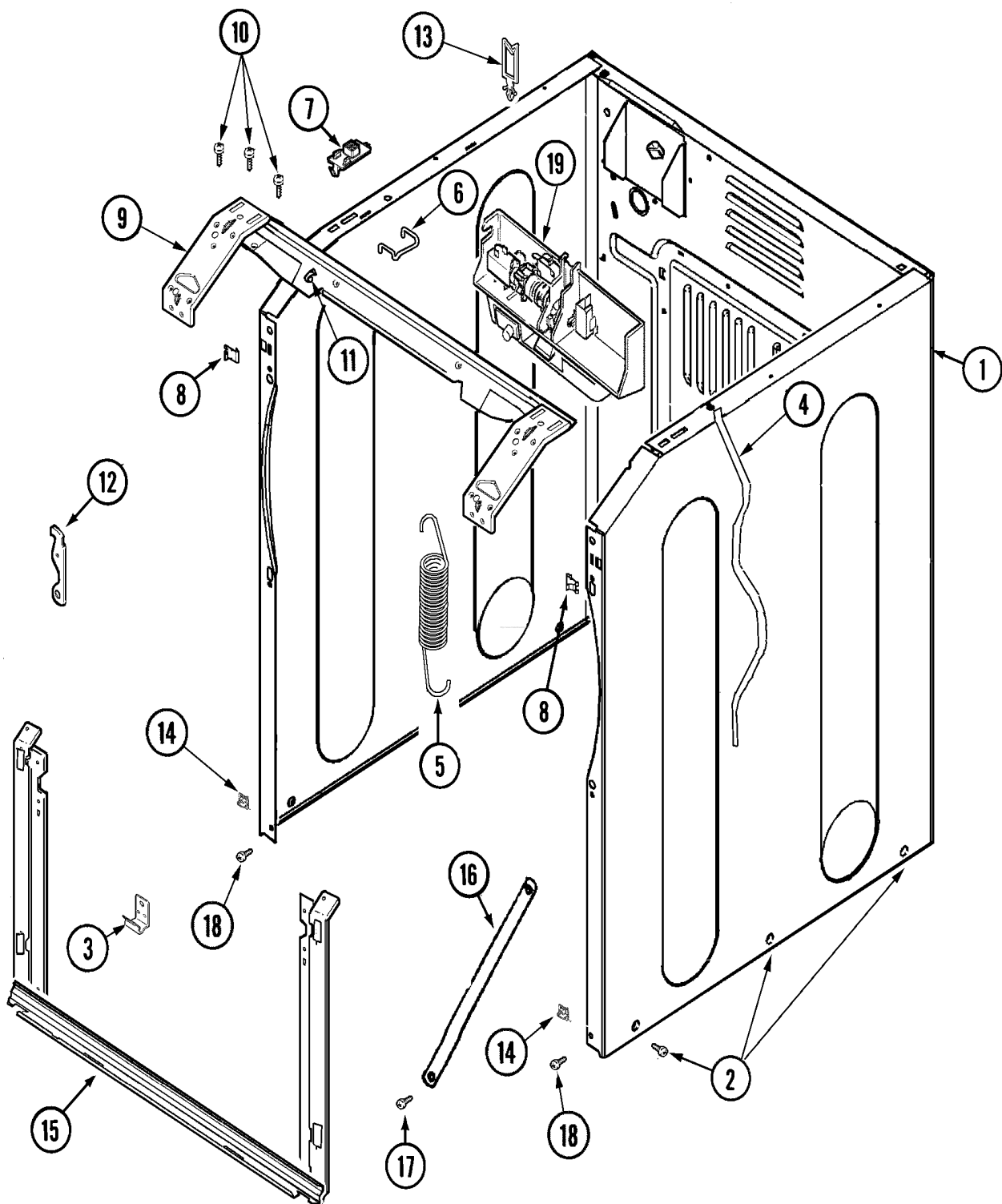

CW12-45

**Section: CABINET-FRONT**

No.	Part No.	Description	Series	Qty
1	22003639	CABINET ASSY. (WHT AS PK)	10	1
2	22003409	SCREW----NA	10	2
3	22002239	CLIP, LOWER FRONT PANEL	10	2
4	33001836	STRAP, TOP COVER SUPPORT	10	1
5	22003254	SPRING, CABINET	10	2
6	22002297	SUPPORT, SPRING	10	1
7	22001997	SPACER, TOP COVER	10	2
8	22002049	CLIP	10	2
9	22003637	BRACE ASSEMBLY, TOP CROSS	10	2
10	22001995	SCREW	10	2
11	22002014	CLIP	10	2
12	33002597	HOOK, SECURITY	10	2
13	22003298	RETAINER, WIRE	10	1
14	22002013	STOP, SHIPPING	10	1
15	22003638	SHROUD SUPPORT ASSEMBLY	10	2
16	22002259	BRACE, CROSS	10	2
17	22001995	SCREW	10	4
18	22001995	SCREW	10	2
19	22003706	DOOR LOCK ASSEMBLY, COMMERCIAL	10	1

\*Color Code (-)=Not Shown #=Series, Serial Prefix or Run No., N=Not Available

Section: DOOR & FRONT PANEL

Model: MAH21PNDWW

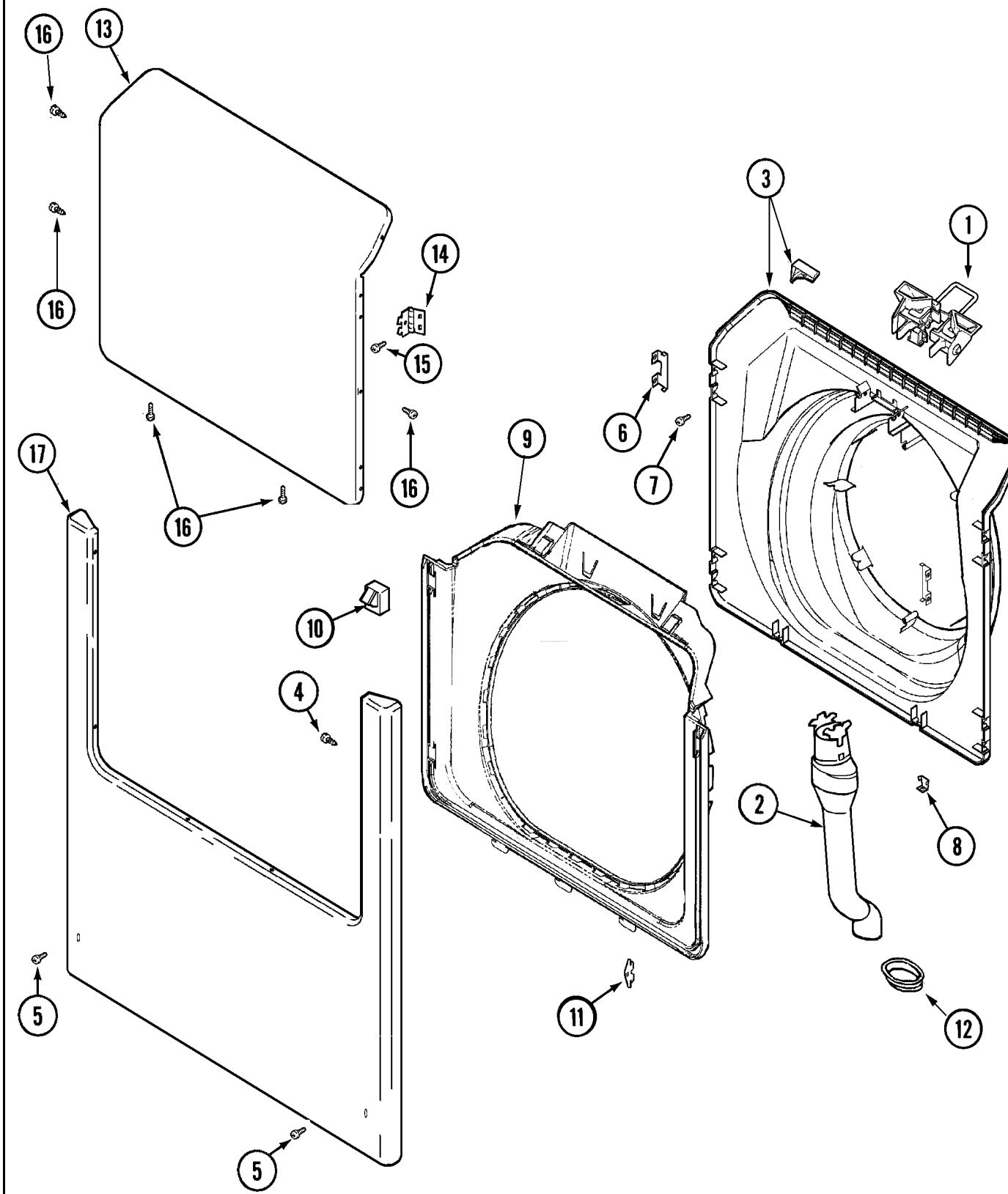

CD12-19



## Section: DOOR & FRONT PANEL

No.	Part No.	Description	Series	Qty
1	22003269	DOOR, LOCK HOOP ASSEMBLY	10	1
2	22003850	VENT TUBE ASSEMBLY	10	1
3	22003275	DOOR, INNER (WHT)	10	1
4	22002244	CLIP, GROUNDING	10	1
5	33002190	SCREW (#10-3/8")	10	2
6	22002038	CLIP, DOOR (DOUBLE)	10	4
7	22002007	SCREW Note: SCREW, STRIKE	10	1
8	22002039	CLIP, DOOR (SINGLE)	10	2
9	N 22003516	SHROUD (WHT)----NA	10	1
10	22002241	PANEL, FRONT (WHT)	10	1
-	33001846	SCREW	10	2
11	33001764	COVER, HINGE HOLE (WHT)	10	2
12	22003075	GROMMET, VENT TUBE	10	1
-	22002333	LABEL, OPEN DOOR (WASHER)	10	1
13	22003785	DOOR, OUTER (WHT)	10	1
14	22002798	HINGE, DOOR	10	2
-	22002244	CLIP, GROUNDING	10	1
15	22002062	SCREW Note: SCREW, HINGE	10	4
15	22002243	SCREW Note: SCREW, FRONT PANEL & HINGE	10	4
16	22002063	SCREW #8-18AB WAFER HD	10	6

\*Color Code (-)=Not Shown #=Series, Serial Prefix or Run No., N=Not Available

Section: CABINET-REAR

Model: MAH21PNDWW

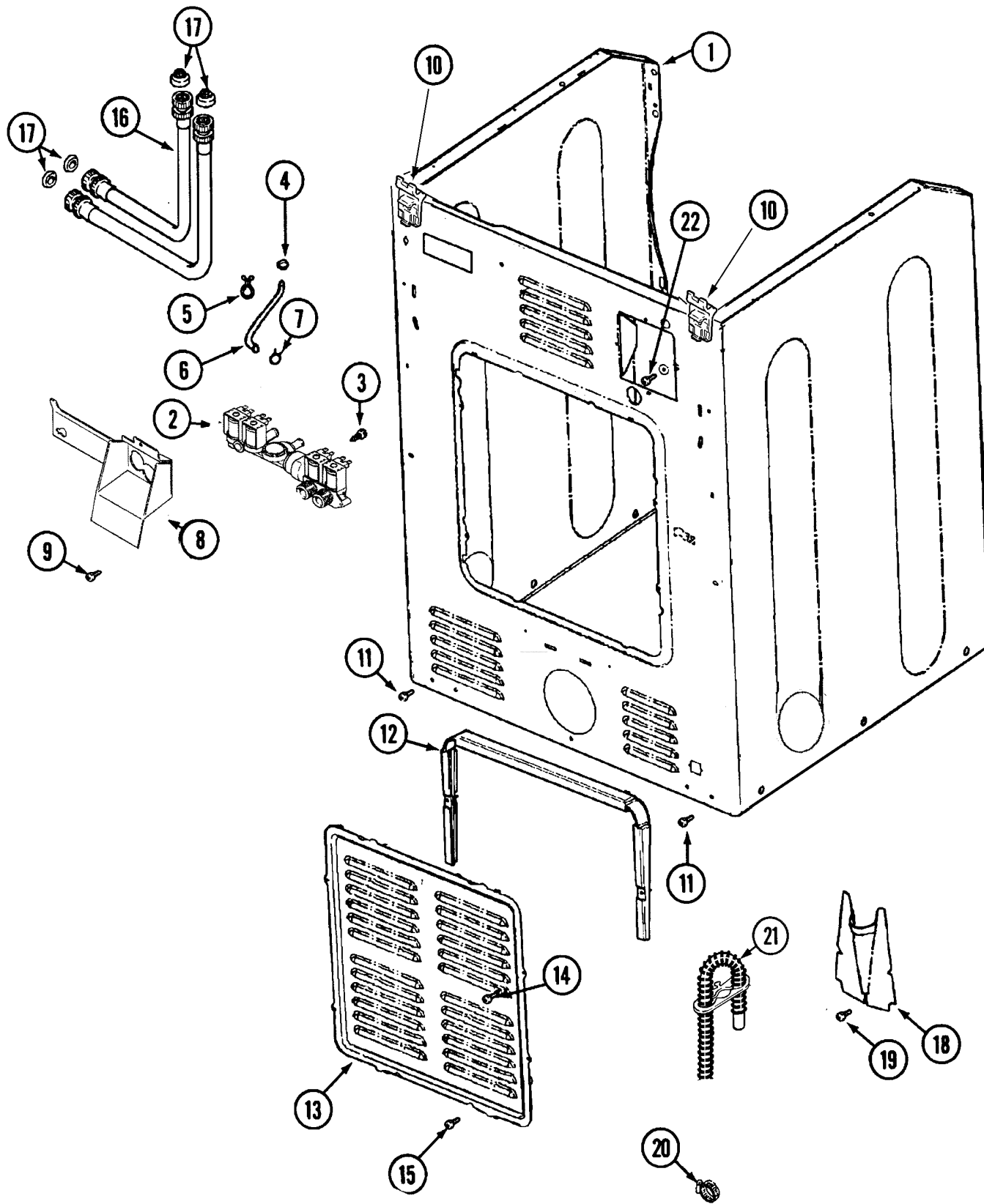

CW12-46

## Section: CABINET-REAR

No.	Part No.	Description	Series	Qty
1	22003639	CABINET ASSY. (WHT AS PK)	10	1
2	22004186	VALVE, WATER	10	1
3	22002925	SCREW Note: SCREW, WATER VALVE	10	2
4	22002054	CLAMP, STEPLESS	10	1
5	22003707	CABLE, TIE	10	2
6	22002083	HOSE, INJECTOR	10	1
7	216169	CLAMP,HOSE-INJEC.HOSE TO VALVE	10	1
8	33002212	BRACKET, WATER VALVE	10	1
9	22002436	SCREW	10	1
10	22004095	HINGE, PLASTIC	10	1
11	22001995	SCREW Note: SCREW, CABINET	10	2
12	22002022	SPACER, ACCESS PANEL	10	1
13	22002092	PANEL, ACCESS	10	1
13	22004355	REAR ACCESS PANEL	11	1
14	22002295	SCREW Note: SCREW, ACCESS PANEL SPACER	10	2
15	22001996	SCREW	10	2
16	22003598	INLET HOSE ASSY. (COLD)	10	1
16	22003597	INLET HOSE ASSY. (HOT)	10	1
17	12001413	STRAINER & WASHER KIT	10	1
18	22002704	COVER, DRAIN HOSE	10	1
19	22001995	SCREW	10	2
20	22001984	CLAMP, DRAIN HOSE	10	2
21	12001659	DRAIN HOSE REPLACEMENT(NEPTUN)	10	1
-	22002892	RETAINER, DRAIN HOSE	10	1
22 N	33001245	SCREW----NA	10	1

\*Color Code (-)=Not Shown #=Series, Serial Prefix or Run No., N=Not Available



## Section: OUTER TUB & MOTOR

No.	Part No.	Description	Series	Qty
-	22002061	SCREW	10	1
1	22004465	OUTER TUB ASSY, AS PACK	10	1
1	22004465	OUTER TUB ASSY, AS PACK	19	1
2	22003302	SWITCH, INTERNAL UNBALANCE	10	1
3	912615	SCREW, #8X1/2 HEX WASHER HEAD Note: SCREW, INERTIAL SWITCH	10	2
3	22002061	SCREW	18	1
4	22004052	HARNESS UPPER SUB ASSY	10	1
5	12002022	LIP SEAL KIT	10	1
6	22003615	BOLT, DOUBLE SEMS 5-3/8	10	2
6	33002973	SCREW, #9-15 X 1.00 HX WS	20	2
7	22002019	SCREW	10	1
8	22003616	BOLT, DOUBLE SEMS 3-3/8	10	1
8	33002973	SCREW, #9-15 X 1.00 HX WS	20	2
9	22002102	WEIGHT, COUNTER BALANCE	10	1
10	22002083	HOSE, INJECTOR	10	1
11	22003627	CLAMP, STEPLESS	10	2
12	22002103	CLIP, U Note: CLIP, U	10	2
13	22002954	DEFLECTOR, WATER (W/ADHESIVE)	10	1
14	22002006	CLIP Note: CLIP, WIRE HARNESS & OUTER TUB	10	6
15	22002065	NUT, COUNTER BALANCE	10	4
16	22002044	SWITCH, TUB DISPLACEMENT	10	2
17	22002061	SCREW Note: SCREW, DISPLACEMENT SWITCH	10	2
18	22002061	SCREW	10	1
18	22002797	CLIP, HOSE (SADDLE HORN) Note: CLIP, WIRE HARNESS	10	1
19	22002006	CLIP Note: CLIP, WIRE HARNESS CLIP	10	4
-	22002019	SCREW Note: SCREW, WIRE HARNESS CLIP	10	1
20	22001984	CLAMP, DRAIN HOSE	10	1
21	22003262	HOSE, TUB TO PUMP	10	1
22	22002053	CLAMP, SUMP HOSE	10	1
-	33002973	SCREW, #9-15 X 1.00 HX WS	20	4
23	22003826	LOWER BRACKET	10	1
23	22004472	BRACKET, LOWER	19	1
24	22002320	WASHER, STRUT	10	1
25	22003827	CUSHION	10	1
26	22002057	SCREW, SPINNER	10	1
27	22003936	WASHER (1 1/4")	10	1
28	22002315	PULLEY, SPINNER	10	1
29	22002313	BELT, DRIVE	10	1
30	22003329	ISOLATOR, MOTOR	10	2
31	22003856	MOTOR, VARIABLE SPEED	10	1
32	22003686	BOLT, MOTOR	10	1
33	22002006	CLIP	10	1
34	22002934	BEARING, FRONT	10	1
35	22002935	SPACER, BEARING	10	1
36	22003441	BEARING, REAR	10	1
-	22002059	SCREW Note: SCREW, SUMP CAP	10	1
37	22003710	SUMP CAP W/ LABYRINTH FEATURE	10	1

\*Color Code (-)=Not Shown #=Series, Serial Prefix or Run No., N=Not Available

Section: SPINNER ASSEMBLY & OUTER TUB COVER

Model: MAH21PNDWW

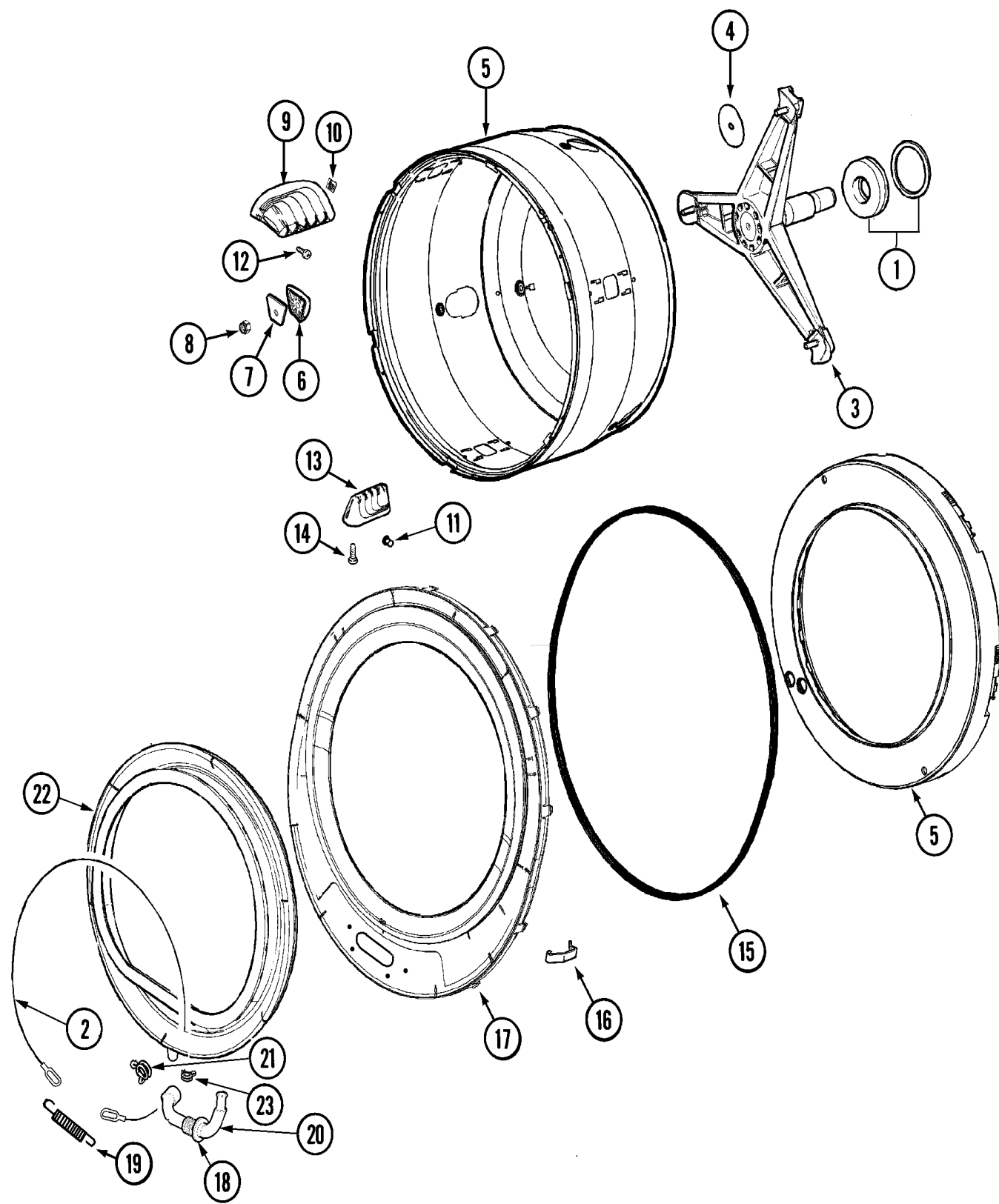

LW13-42

## Section: SPINNER ASSEMBLY & OUTER TUB COVER

No.	Part No.	Description	Series	Qty
1	12002022	LIP SEAL KIT	10	1
2	22002327	BOOT CABLE CLAMP	10	1
-	22002123	TUBE, MOLYKOTE	10	1
3	22004081	SPINNER SUPPORT ASSY AS-PK KIT	10	1
4	22002023	WASHER, PLASTIC	10	3
5	22003549	SPINNER ASSY. (W/BALANCE RING)	10	1
6	22002482	WASHER, PROFILE	10	3
7	22002020	WASHER, SPINNER SUPPORT	10	3
8	22002122	NUT, SPINNER ATTACHMENT	10	3
9	22001985	BAFFLE, DRIP (REAR)	10	3
10	22002009	GROMMET, BAFFLE (REAR)	10	3
11	22001999	GROMMET, BAFFLE (FRT)	10	3
12	22003556	SCREW Note: SCREW, BAFFLE (REAR)	10	6
13	22001986	BAFFLE, DRIP (FRONT)	10	3
14	22002059	SCREW Note: SCREW, BAFFLE (FRONT)	10	6
15	22002077	SEAL, TUB COVER	10	1
16	22002050	CLIP, TUB TO COVER	10	12
17	22004264	ASSY., TUB COVER & SEAL	10	1
18	22003074	GUARD, HOSE	10	1
19	22002099	SPRING, TUB	10	1
20	22003071	DOOR BOOT DRAIN HOSE Note: HOSE, DOOR BOOT DRAIN	10	1
21	22003072	CLAMP, HOSE DOUBLE WIRE	10	1
22	22003893	DOOR BOOT, BLACK	10	1
23	22003073	CLAMP, HOSE DOUBLE WIRE	10	1
-	22003081	PLUG	10	1

\*Color Code (-)=Not Shown #=Series, Serial Prefix or Run No., N=Not Available

Section: BASE & MOTOR CONTROL

Model: MAH21PNDWW

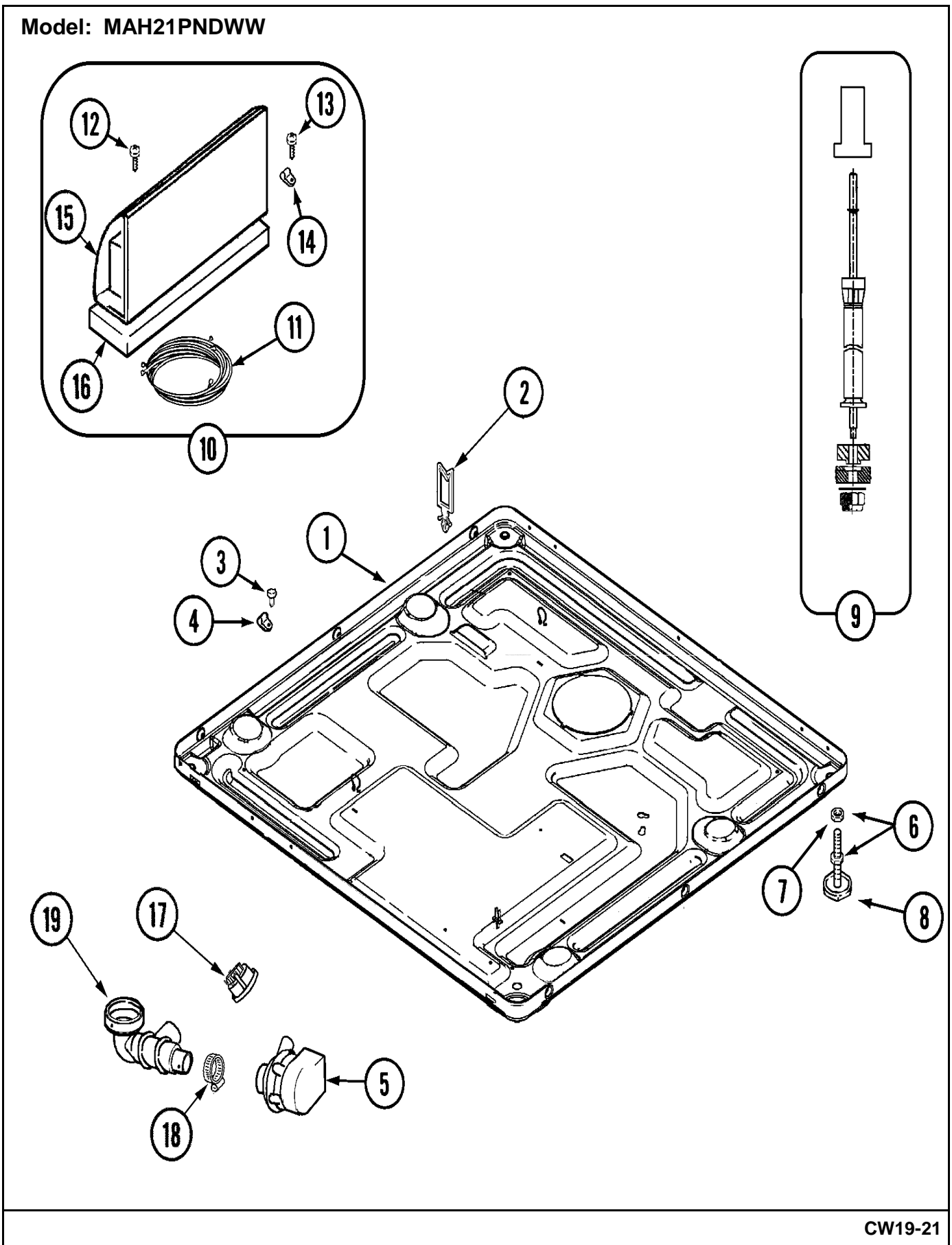



## Section: BASE & MOTOR CONTROL

No.	Part No.	Description	Series	Qty
1	22003926	COMMERCIAL BASE WELD ASSY	10	1
-	22003298	RETAINER, WIRE	10	5
2	315471	RETAINER, WIRE Note: RETAINER, WIRE	10	3
3	212276	SCREW Note: SCREW, WIRE HARNESS CLIP	10	1
4	22002014	CLIP Note: CLIP, WIRE HARNESS	10	2
-	22002853	CLAMP, HOSE	10	1
-	22003268	CAP, RUBBER	10	1
5	22003244	PUMP	10	1
6	22003544	ADJUSTABLE LEG W/FOOT & NUT	10	4
7	Y052740	NUT Note: NUT, LEG	10	4
8	210684	FOOT, RUBBER	10	4
9	22001988	STRUT ASSY-REAR	10	2
10	22004046	CONTROL ASSY., MOTOR	10	1
10	22004473	MOTOR CONTROL ASSEMBLY	22	1
10	22004473	MOTOR CONTROL ASSEMBLY	23	1
11	22004047	HARNESS, MOTOR/MOTOR CONTROL	10	1
12	212276	SCREW Note: SCREW, MOTOR CONTROL BRACKET	10	2
13	210720	RIVET Note: RIVET, WIRE HARNESS CLIP	10	1
14	22002173	CLIP, WIRE HARNESS	10	1
15	22003773	SHIELD, MOTOR CONTROL BOARD	10	1
-	22003777	MOTOR CONTROL DRIP SHIELD	10	1
16	22003548	BRACKET, MTG. (SR MOTOR CTL)	10	1
17	22003728	SWITCH, PRESSURE	10	1
18	22001984	CLAMP, DRAIN HOSE	10	1
-	22002053	CLAMP, SUMP HOSE	10	1
19	22003262	HOSE, TUB TO PUMP	10	1

\*Color Code (-)=Not Shown #=Series, Serial Prefix or Run No., N=Not Available

# Section: WIRING INFORMATION

Model: MAH21PNDWW

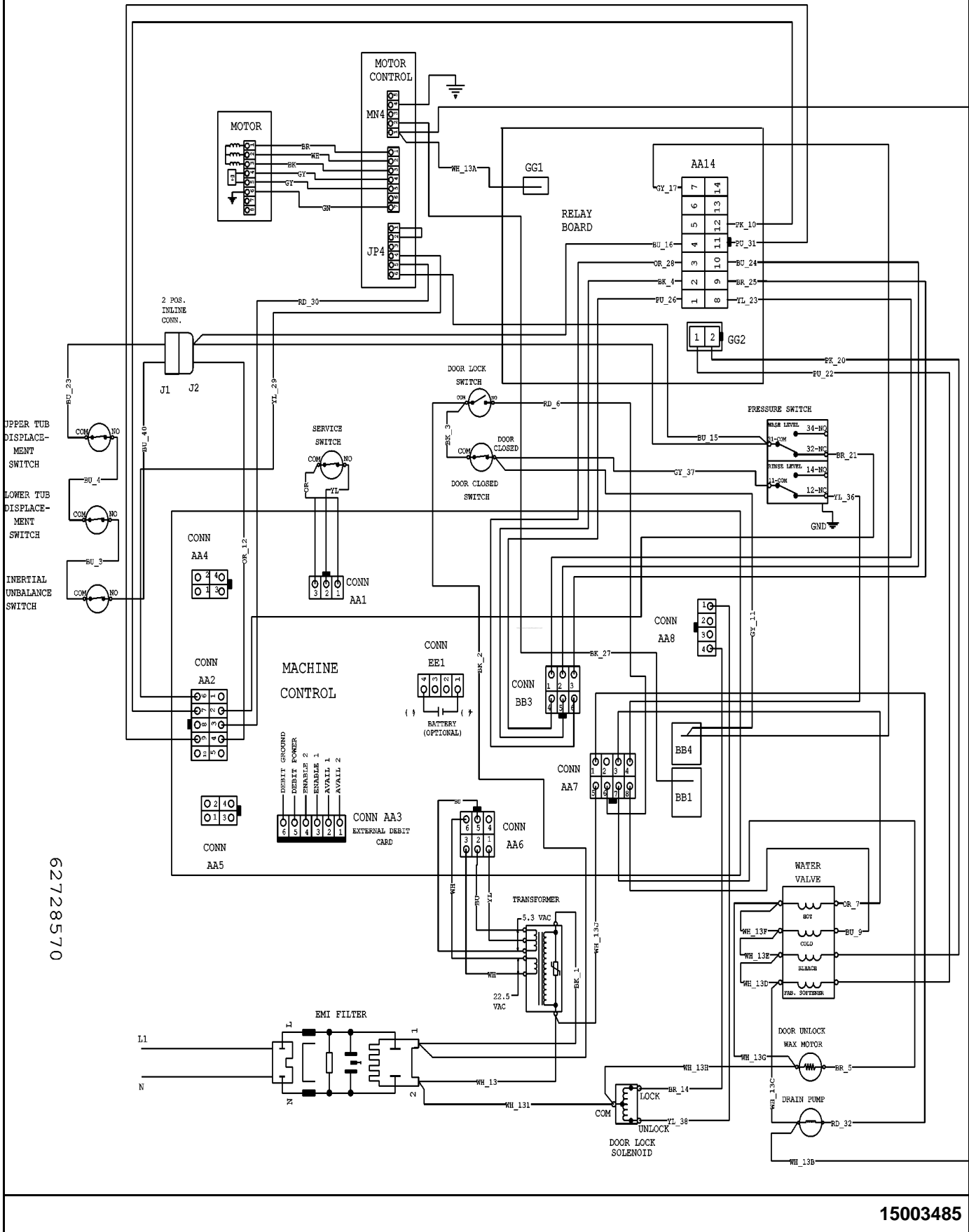

62728570

15003485

**Section: WIRING INFORMATION SER-15**

**Model: MAH21PNDWW**

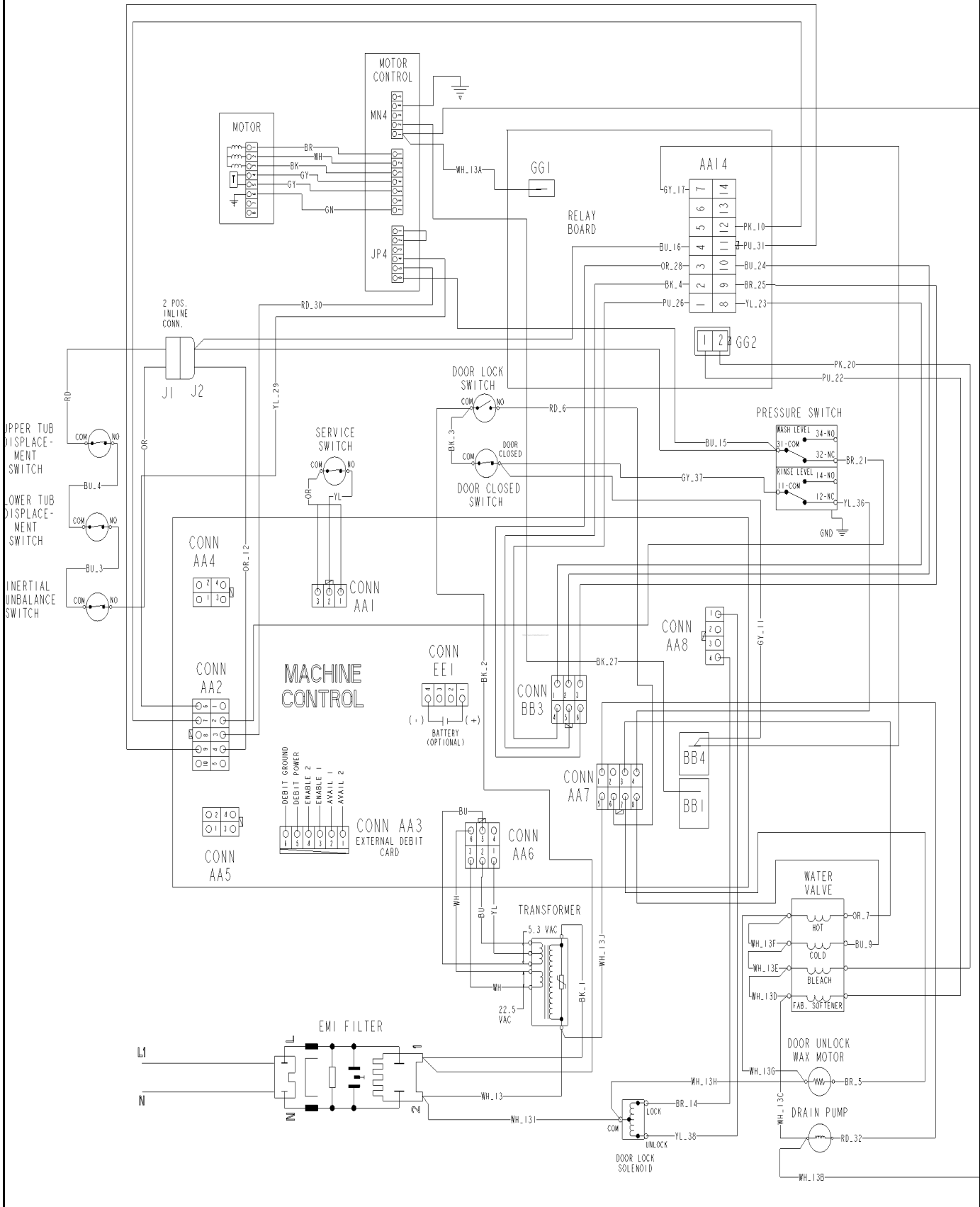

15003567

**Section: WIRING INFORMATION SER-15**

No.	Part No.	Description	Series Qty
1	N 15003567	WIRING INFORMATION	15 1

\*Color Code (-)=Not Shown #=Series, Serial Prefix or Run No., N=Not Available

