



# MAP3205

## 4-channel LED Driver for High Brightness LEDs

MAP3205 – 4-Channel LED Driver for High Brightness LEDs

### General Description

The MAP3205 is a 4-channel LED driver optimized for LED backlight application targeting mid and large size LCD module. It uses the boost MOSFET externally and 4-channel current sources internally for driving high brightness white LEDs.

Input voltage of the MAP3205 is ranged from 8V to 36V and max. LED current is 150mA per channel. It can increase the output voltage depending on the drain voltage rating of boost MOSFET.

It features PWM dimming control, internal soft-start and has unique adaptive internal OVP, boost MOSFET OCP, LED short/open protection, SBD open protection and UVLO.

The MAP3205 is available in 20 leads E-TSSOP and 20 leads SOIC package with Halogen-free (fully RoHS compliant).

### Features

- 8V to 36V Input Voltage Range
- Drive up to 4 Channels
- Max. 150mA Output Current per Channel
- Programmable Boost Switching Frequency : 200kHz to 500kHz
- PWM Dimming : Up to 22kHz, Min on-time : 20us
- Analog Dimming
- SBD Open Protection
- Boost Over-Current Protection
- Internal Adaptive Over-Voltage Protection
- LED Short/Open Protection
- UVLO
- 20 leads E-TSSOP and 20 leads SOIC

### Applications

- High Brightness white LED backlighting for mid and large size LCD module
- General LED lighting applications

### Ordering Information

Part Number	Top Marking	Ambient Temperature Range	Package	RoHS Status
MAP3205SIRH	MAP3205	-40°C to +85°C	20 leads SOIC	Halogen Free
MAP3205TERH	MAP3205	-40°C to +85°C	20 leads TSSOP with E-Pad	Halogen Free

### Typical Application

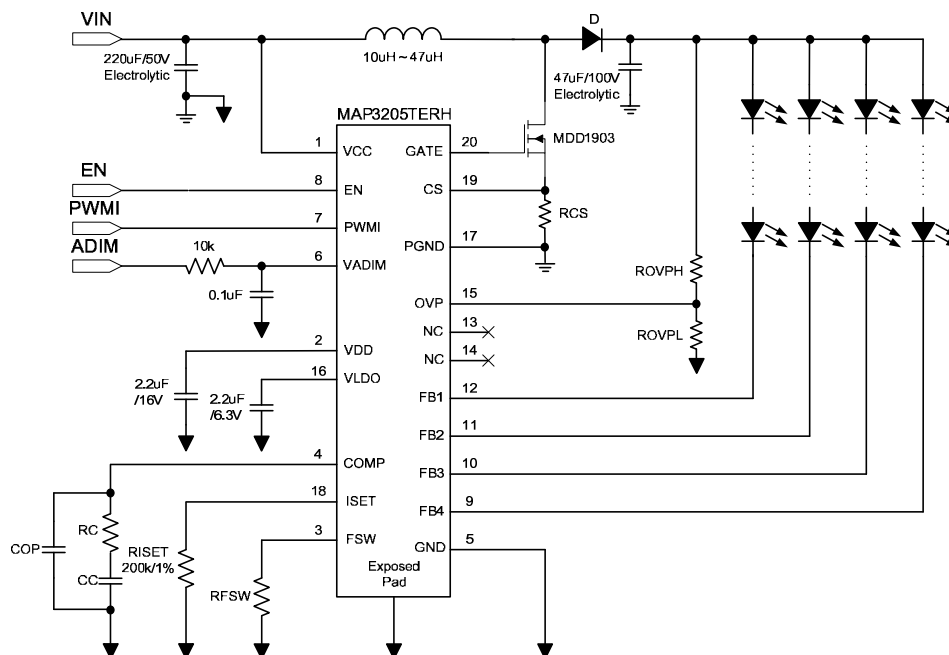

Pin Configuration

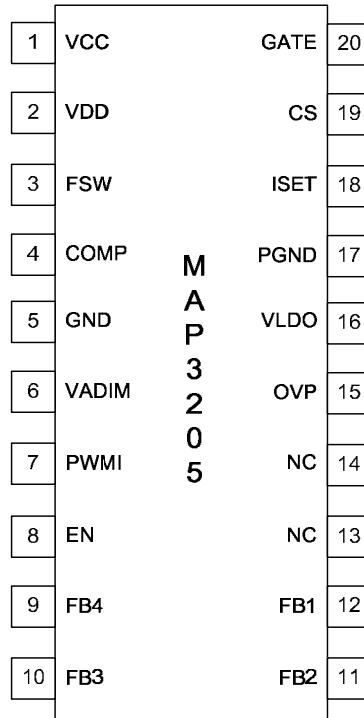

20 leads E-TSSOP / 20 leads SOIC

Functional Block Diagram

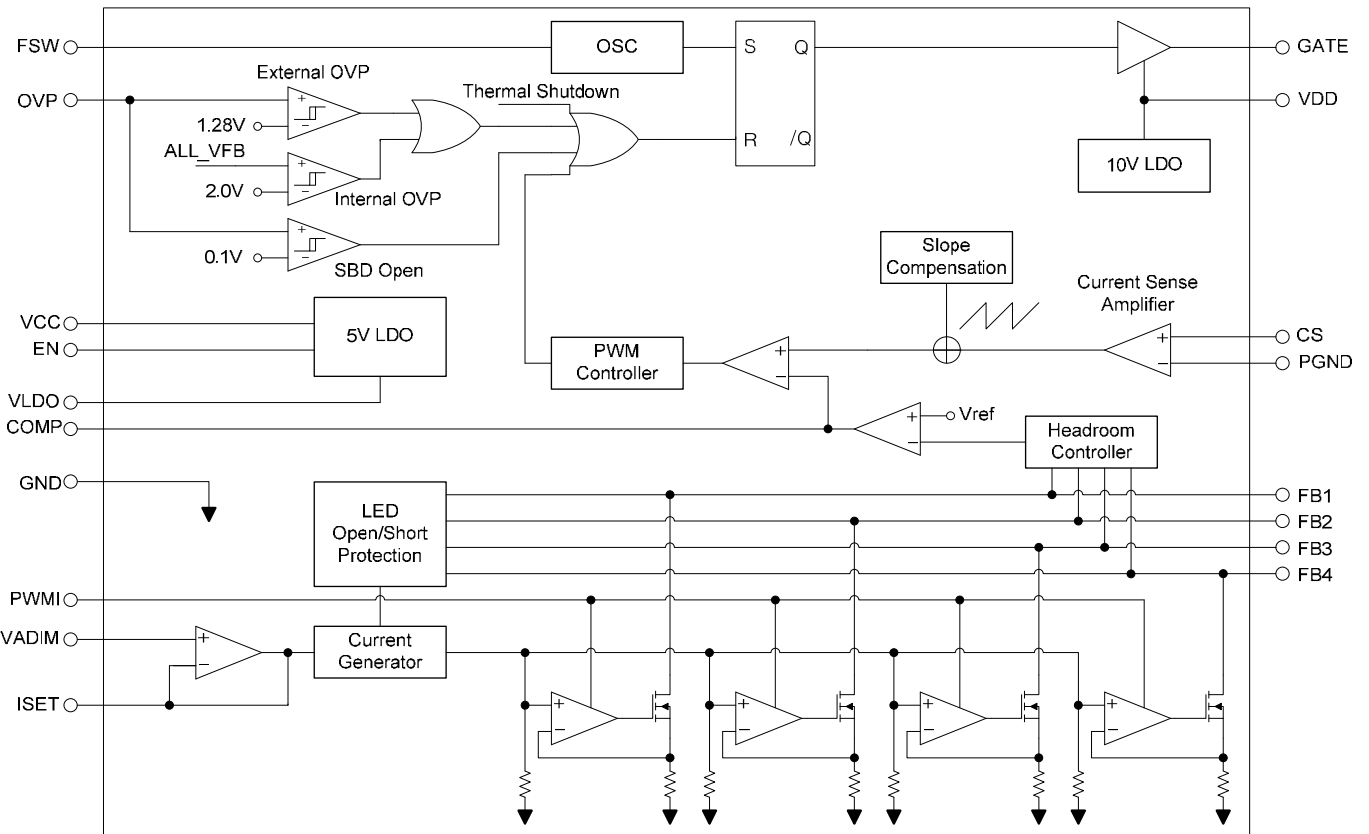

## Pin Description

20leads E-TSSOP/SOIC	Name	Description
1	VCC	Power supply input. Need external input capacitor
2	VDD	Internal 10V Regulator Output. Need external 2.2uF capacitor
3	FSW	Booster switching frequency adjustment pin (Note 1)
4	COMP	Internal error amplifier compensation pin (Note 2)
5	GND	Ground
6	VADIM	Max. LED current adjustment pin
7	PWMI	PWM signal input for dimming (Note 3)
8	EN	Enable pin. Active High.
9	FB4	LED current sink for Ch4
10	FB3	LED current sink for Ch3
11	FB2	LED current sink for Ch2
12	FB1	LED current sink for Ch1
13	NC	No connection
14	NC	No connection
15	OVP	Over Voltage Protection (Note 4)
16	VLDO	Internal 5V Regulator Output. Need external 2.2uF capacitor
17	PGND	Power Ground
18	ISET	ILED reference resistor setting pin (Note 5)
19	CS	Boost current sense pin (Note 6)
20	GATE	Gate driver output for external power MOSFET
-	Exposed PAD	Connect to ground by multiple vias for heat-sinking purpose (Note 7)

**Note 1:** Connect external resistor to set the oscillator frequency from 200kHz to 500kHz.

**Note 2:** Connect external capacitor and resistor to COMP pin. Refer to a typical application diagram.

**Note 3:** This external PWM signal is used for brightness control.

**Note 4:** Connect center node of resistive voltage divider from output to ground. Refer to a typical application diagram.

**Note 5:** Connect external 200k $\Omega$ /1% resistor to GND. Refer to a typical application diagram.. Do not leave this pin open.

**Note 6:** Connect external resistor to PGND to sense the external power MOSFET drain current.

**Note 7:** Not connected internally.

**Absolute Maximum Ratings** (Note 1)

Symbol	Parameter	Min	Max	Unit
$V_{CC}$	Supply Voltage	-0.3	36	V
$V_{GATE}$	Gate Driver Output	-0.3	14	V
$V_{VDD}$	VDD Pin	-0.3	14	V
$V_{EN}, V_{CS}, V_{PWMI}, V_{COMP}, V_{FSW}, V_{VLDO}, V_{ISET}, V_{OVP}, V_{VADIM}$	Voltage Level on EN, CS, PWMI, COMP, FSW, VLDO, ISET, OVP, VADIM Pin	-0.3	7	V
$V_{FB1-4}$	LED Current Sink Pin	-0.3	65	V
$I_{FB1-4}$	LED Current Sink Pin		200	mA
$T_{PAD}$	Soldering Lead/ Pad Temperature 10sec		300	°C
$T_J$	Junction Temperature	-40	+150	°C
$T_S$	Storage Temperature	-65	+150	°C
ESD	HBM on All Pins (Note 2)	-2000	+2000	V
	MM on All Pins (Note 3)	-200	+200	

**Note 1:** Stresses beyond the above listed maximum ratings may damage the device permanently. Operating above the recommended conditions for extended time may stress the device and affect device reliability. Also the device may not operate normally above the recommended operating conditions. These are stress ratings only.

**Note 2:** ESD tested per JESD22A-114.

**Note 3:** ESD tested per JESD22A-115.

**Recommended Operating Conditions** (Note 1)

Parameter	Min	Max	Unit	
$V_{CC}$	Supply Input Voltage	8	36	V
$I_{FB1-4}$	LED Current Sink Pin	50	150	mA
$V_{FB1-4}$	LED Current Sink Pin		65	V
$T_A$	Ambient Temperature (Note 2)	-40	+85	°C

**Note 1:** Normal operation of the device is not guaranteed if operating the device over outside range of recommended conditions.

**Note 2:** The ambient temperature may have to be derated if used in high power dissipation and poor thermal resistance conditions.

**Package Thermal Resistance** (Note 1)

Parameter	$\theta_{JA}$	$\theta_{JC}$	Unit	
MAP3205SIRH	20 Leads SOIC	54	26	°C/W
MAP3205TERH	20 Leads E-TSSOP	43	4	°C/W

**Note 1:** Measured on JESD51-7, Multi-layer PCB

## Electrical Characteristics

Unless noted,  $V_{IN} = 12V$ ,  $C_{IN} = 1.0\mu F$ , and typical values are tested at  $T_A = 25^\circ C$ . **Boldface** values indicate  $-40^\circ C$  to  $+85^\circ C$  of  $T_A$ .

Parameter	Test Condition	Min	Typ	Max	Unit	
<b>General Input Output</b>						
$V_{CC}$	Input Voltage Range	<b>8.0</b>		<b>36</b>	V	
$I_Q$	Quiescent Current	$V_{CC} = 12V$ , $V_{EN} = 5V$ , $V_{PWMI} = 0V$	3.5		mA	
$I_{GND}$	Ground Pin Current in Shutdown	$V_{CC} = 12V$ , $V_{EN} = 0V$ , $V_{PWMI} = 0V$		100	$\mu A$	
$V_{EN}$	Logic Input Level on EN pin	$V_{EN\_L}$ : Logic Low		0.8	V	
		$V_{EN\_H}$ : Logic High	2.0			
$R_{EN\_PULLDOWN}$	Pull-down resistor on EN pin		500		k $\Omega$	
$V_{UVLO}$	Under-Voltage Lock-Out Threshold Voltage on VDD pin	Release UVLO		6.0	V	
		Lockout UVLO	4.0	5.5		
<b>Oscillator</b>						
$f_{SW}$	Internal Oscillator Frequency	$R_{FSW}=250k\Omega$	<b>180</b>	<b>200</b>	<b>220</b>	kHz
		$R_{FSW}=100k\Omega$	<b>425</b>	<b>500</b>	<b>575</b>	
$D_{max}$	Maximum Duty Cycle		86	90	%	
<b>Reference</b>						
$V_{VDD}$	10V LDO Voltage	$V_{CC} > 12V$ , No load current	<b>9</b>	<b>10</b>	<b>11.5</b>	V
$V_{LDO}$	5V LDO Voltage	$V_{CC} > 8V$ , No load current	<b>4.5</b>	<b>5</b>	<b>5.5</b>	V
<b>Boost MOSFET Driver</b>						
$V_{GATE}$	Gate Drive Voltage	$V_{CC} > 12V$	9	10	11.5	V
$I_{SINK}$	Gate Sink Current	$V_{DD} = 10V$ , $V_{GATE} = 4V$	0.05		0.4	A
$I_{SOURCE}$	Gate Source Current	$V_{DD} = 10V$ , $V_{GATE} = 0V$	0.05		0.4	A
$t_{RISE}$	Gate Output Rising Time	10nF load capacitance			500	ns
$t_{FALL}$	Gate Output Falling Time	10nF load capacitance			500	ns
<b>Protection</b>						
$T_{SD}$	Thermal Shutdown Temperature	Shutdown Temperature		150		$^\circ C$
		Hysteresis, $\Delta T_{SD}$		25		
$V_{EXTOVP}$	Over-Voltage Protection Threshold Level on OVP pin	Rising Over-Voltage Limit on OVP pin	1.23	1.28	1.33	V
		Hysteresis, $\Delta V_{EXTOVP}$	0.02		0.12	
$V_{INTOVP}$	Internal Over-Voltage Protection Threshold Level on FB pin	Rising Over-Voltage Limit on FB pin (Note1)	1.9	2.0	2.1	V
		Hysteresis, $\Delta V_{INTOVP}$ (Note1)	0.54		0.74	
$V_{LEDSHORT}$	LED Short Protection Threshold	FB1 ~ FB4		5.5		V
$V_{SBDOPEN}$	SBD Open Protection Threshold on OVP pin	(Note1)		0.1		V
$t_{SCP}$	LED Short Protection Time	$f_{SW}=500kHz$		8.192		ms
$V_{CS}$	Boost Over Current Protection Threshold	Gate Duty-Cycle=90%	0.306	0.360	0.414	V
$V_{LEDOPEN}$	LED Open Protection Threshold	$I_{LED}=50mA$		0.05		V
		$I_{LED}=150mA$		0.15		V
<b>LED Current Sink Regulator</b>						
$V_{FB1-4}$	Minimum FB1~FB4 voltage for the operation to sink 150mA	$I_{LED}=150mA$		0.8		V
$I_{FB}$	Current Accuracy	$I_{LED}=100mA$			$\pm 3$	%
$Km$	Current Matching(Note 2)	$I_{LED}=100mA$			$\pm 2.5$	%
$I_{FB\_max}$	Current Sink max Current	VADIM=3V		<b>150</b>		mA
$V_{ADIM}$	ADIM Input Voltage Range		1		3	V
<b>PWM Interface</b>						
$f_{PWM}$	PWM dimming frequency		0.1		22	kHz
$V_{PWMI}$	Logic Input Level on PWMI pin	$V_{PWMI\_L}$ : Logic Low			0.8	V
		$V_{PWMI\_H}$ : Logic High	2.3			
$I_{PWMI}$	Leakage Current on PWMI pin	$V_{PWMI}=1V$			4	$\mu A$
$t_{PWMON\_MIN}$	Minimum On-Duty	$f_{PWM}=500Hz$		20		us

Note 1. No test on mass production

Note 2.

$$Km[\%] = \pm \frac{I_{max} - I_{min}}{I_{max} + I_{min}} \times 100$$

### Typical Operating Characteristics

Unless otherwise noted,  $V_{IN} = 24V$ ,  $I_{LED} = 100mA$ , LED string=4 \* 15,  $C_{in}=22\mu F$ ,  $C_{out}=47\mu F * 2$  and  $T_A = 25^\circ C$ .

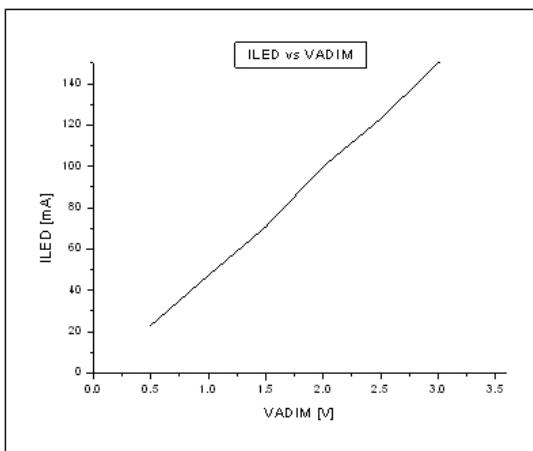
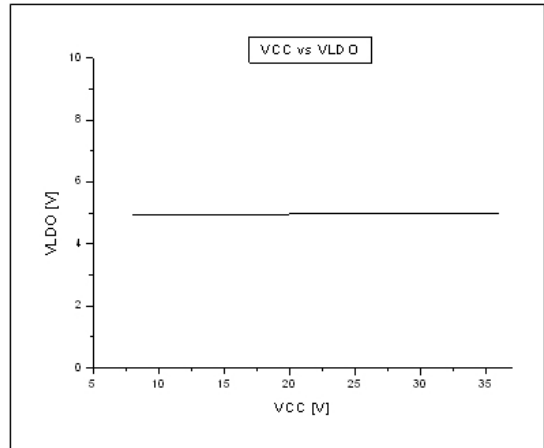
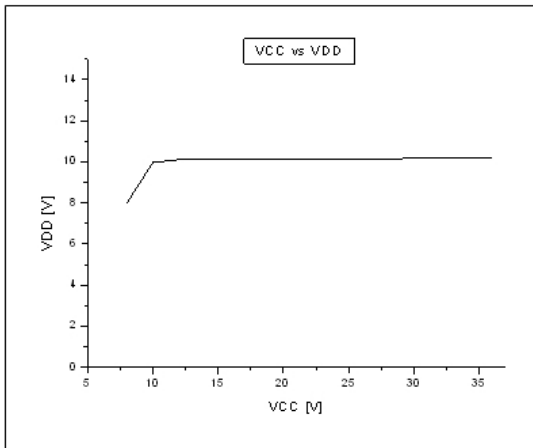
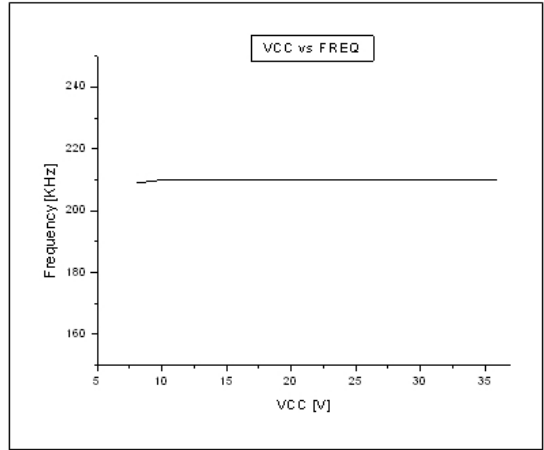
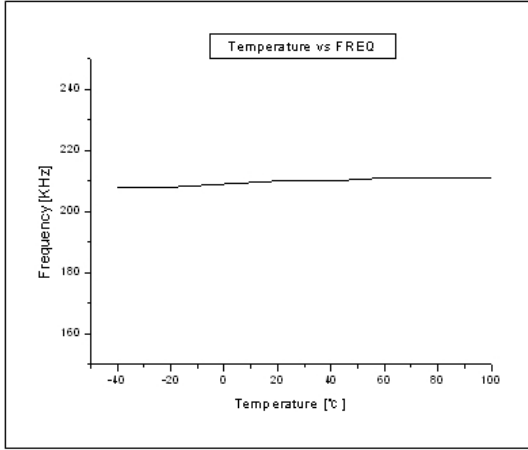

### Vcs\_typ vs. Duty Cycle

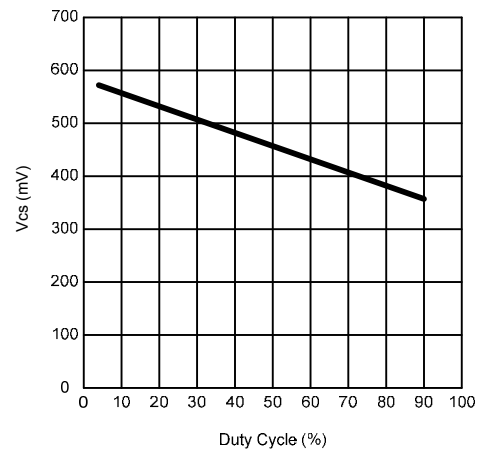

### Typical Operating Characteristics

Unless otherwise noted,  $V_{IN} = 24V$ ,  $I_{LED} = 100mA$ , LED string=4 \* 15,  $C_{in}=22\mu F$ ,  $C_{out}=47\mu F * 2$  and  $T_A = 25^\circ C$ .

CCM Operation

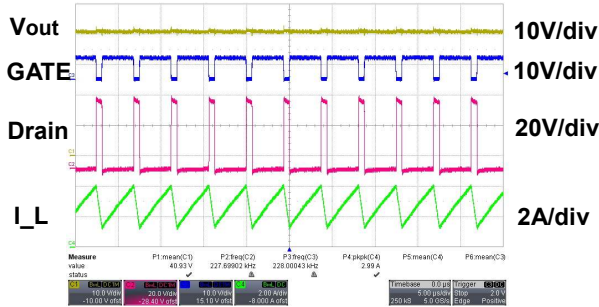

DCM Operation

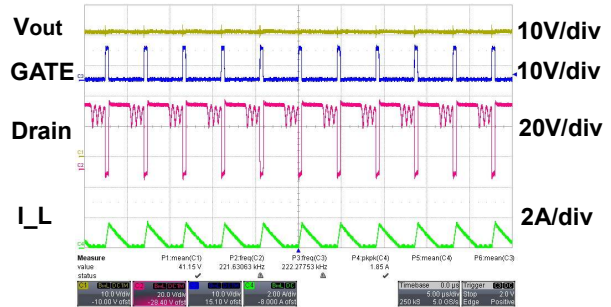

Turn-on

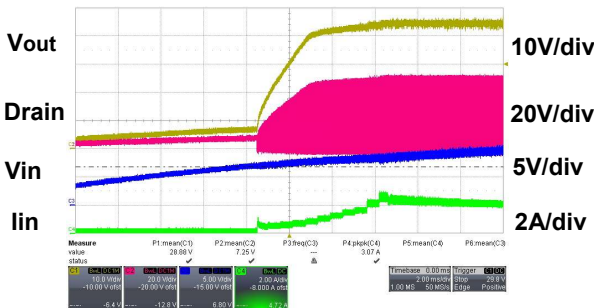

Turn-off

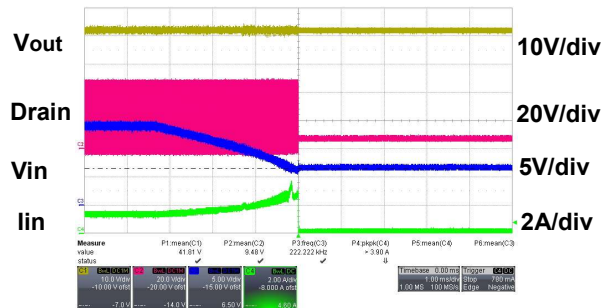

Min. dimming(PWM=500Hz/20us)

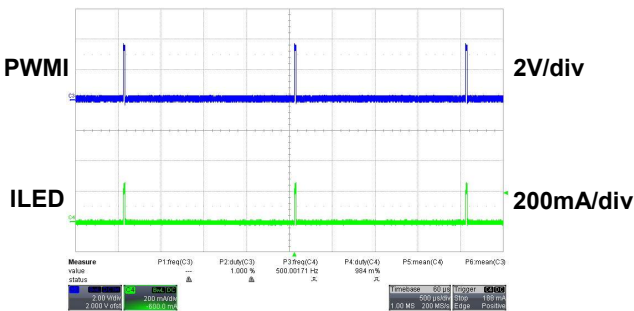

SBD open protection

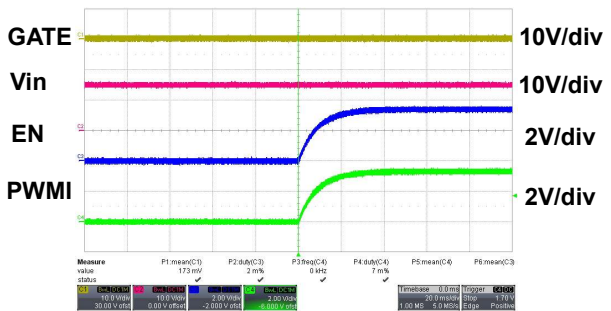

LED open protection

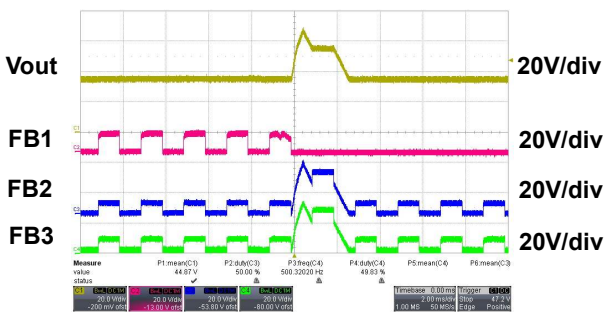

LED short protection

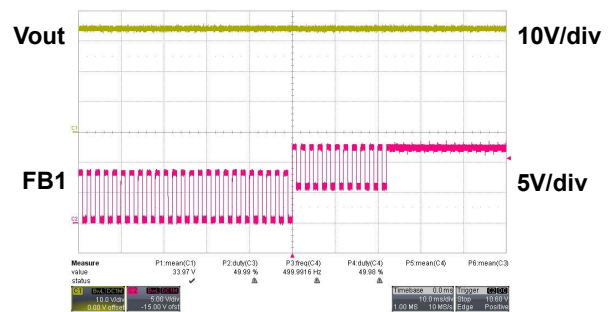

## Application Information

### CURRENT MODE BOOST SWITCHING CONTROLLER OPERATION

The MAP3205 employs current mode control boost architecture that has a fast current sense loop and a slow voltage feedback loop. Such architecture achieves a fast transient response that is essential for the LED backlight application.

### DYNAMIC HEADROOM CONTROL

The MAP3205 features a proprietary Dynamic Headroom Control circuit that detects the lowest voltage from any of the FB1-FB4 pins. This lowest channel voltage is used as the feedback signal for the boost controller. Since all LED stacks are connected in parallel to the same output voltage, the other FB pins will have a higher voltage, but the regulated current source circuit on each channel will ensure that each channel has the same current.

### INTERNAL 5V/10V REGULATOR

The MAP3205 has built-in 5V LDO regulator to supply internal analog and logic blocks. The LDO is powered up when the EN pin is Logic High. A 2.2uF bypass capacitor is required for stable operation of the LDO.

A 10V LDO is used to drive external MOSFET connected to the GATE pin. A 2.2uF bypass capacitor is required for stable operation of the LDO.

### DIMMING SCHEME

The brightness control of the LEDs is performed by a pulse-width modulation of the channel current. When a PWM signal is applied to the PWMI pin, the current generators are turned on and off mirroring the PWMI pin behavior.

When PWMI signal stays at low level (<0.8V) for a long time, the MAP3205 turns off the boost circuitry, but internal circuit is enabled so the MAP3205 increases the output voltage promptly.

The minimum dimming on duty is 1% at 500Hz(=20us).

### BOOST SWITCHING FREQUENCY ADJUSTMENT

The switching frequency of the MAP3205 should be programmed between 200kHz and 500kHz by an external resistor connected between the FSW pin and ground. Do not leave this pin open. The approximate operating boost switching frequency can be calculated by following equation.

$$f_{sw}[MHz] = \frac{50}{R_{FSW}[k\Omega]}$$

### LED CURRENT ADJUSTMENT

The MAP3205 sets the LED current through the voltage level on VADIM pin. VADIM pin voltage vs. LED current is as below table. A 200kΩ/1% resistor must be connected between the ISET pin and ground.

VADIM Voltage [V]	LED Current [mA]
1.0	50
1.2	60
1.4	70
1.6	80
1.8	90
2.0	100
2.2	110
2.4	120
2.6	130
2.8	140
3.0	150

If the VADIM voltage is fixed, the LED current can also be programmed by following equation.

$$I_{LED}[mA] = \frac{VADIM}{R_{ISET}[k\Omega]} \times 10000$$

### OVER VOLTAGE PROTECTION

#### (1) External OVP

The MAP3205 features a dedicated overvoltage feedback input. The OVP pin is connected to the center tap of resistive voltage-divider from the high voltage output(see the typical application). When one or more channels are opened, the output voltage is boosted to external OVP level and OVP pin voltage exceeds typical 1.28V. A corresponding comparator turns off the external power MOSFET. This switch is re-enabled after the OVP pin voltage drops hysteresis voltage(ΔEXTOVP) below the protection threshold.

This over voltage protection feature ensures the boost converter fail-safe operation when the LED channels are disconnected from the output.

The OVP level can be calculated with the following equation.

$$V_{OUT\_EXT\_OVP} = 1.28 \times \frac{R_{OVPH} + R_{OVPL}}{R_{OVPL}}$$

#### (2) Internal adaptive OVP

The MAP3205 features an adaptive internal OVP by sensing the FB voltage.

When all the FB voltage exceeds typical 2V, a corresponding comparator turns off the external MOSFET. This switch is re-enabled after all the FB voltage drops hysteresis voltage(ΔINTOVP) below the protection threshold.



## BOOST OVER-CURRENT PROTECTION

The MAP3205 features Over-Current Protection (OCP) by sensing CS pin voltage. This CS pin is used for inductor current sensing for current mode control as well.

The internal OCP sensing voltage decreases with increase of gate duty-cycle due to internal slope compensation which ensures stable CCM operation.

Following graph shows the relationship between gate duty-cycle and internal OCP sensing voltage.

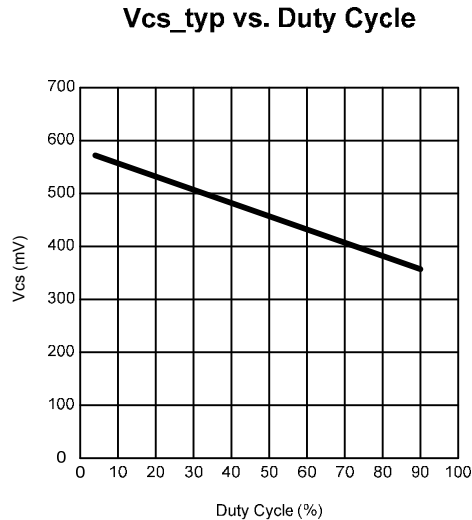

In order to avoid touching the current limit during normal operation, the voltage across the current sensing resistor  $R_{CS}$  should be less than 80% of the worst case current limit voltage.

$$R_{CS} = 0.8 \times \frac{V_{CS}}{I_{L\_PEAK}}$$

## SBD OPEN PROTECTION

When OVP pin voltage is less than 0.1V, a corresponding comparator turns off the external MOSFET.

This protects the driver from damage if the output schottky diode is open(defective or poor solder contact).

## LED OPEN PROTECTION

In case the voltage at any of FB1~4 pins is below LED open protection threshold( $V_{LEDOPEN}$ ) due to LED open during normal operation, the MAP3205 excludes the corresponding string and the remaining string(s) will continue operation. Once the LED open status is removed, the corresponding string is automatically recovered.

## LED SHORT PROTECTION

If the voltage at any of the FB1-4 pins exceeds a threshold of approximately 5.5V due to LED short during normal operation, the MAP3205 turns off the corresponding string after LED short protection time( $t_{scp}$ ) and the remaining string(s) will continue operation. The operation is resumed recycling the EN pin or applying a complete power-on-reset(POR).

## PARALLEL OPERATION

Even the MAP3205 has 4 channel and 150mA LED current capability per channel, 2 channel and 300mA application can be supported by tying 2FBs into 1ch, so the LED current capability can be increased to 300mA.

## EXTERNAL COMPONENTS SELECTION

### Inductor

The inductor value should be decided before system design. Because the selection of the inductor affects the operating mode of CCM(Continuous Conduction Mode) or DCM(Discontinuous Conduction Mode). In CCM operation, inductor size should be bigger, even though the ripple current and peak current of inductor can be small. In DCM operation, even ripple current and peak current of inductor should be large while the inductor size can be smaller.

The inductor DC current or input current can be calculated as following equations.

$$I_{IN} = \frac{V_{OUT} \times I_{OUT}}{V_{IN} \times \eta}$$

$\eta$  – Efficiency of the boost converter

Then the duty ratio is,

$$D = \frac{V_{OUT} - V_{IN} + V_D}{V_{OUT} + V_D}$$

$V_D$  – Forward voltage drop of the output rectifying diode

When the boost converter runs in DCM ( $L < L_{critical}$ ), it takes the advantages of small inductance and quick transient response. The inductor peak current is,

$$I_{L\_peak\_DCM} = \frac{V_{IN} \times D}{f_{SW} \times L}$$

The converter will work in CCM if  $L > L_{critical}$ , generally the converter has higher efficiency under CCM and the inductor peak current is,

$$I_{L\_peak\_CCM} = I_{IN} + \frac{V_{IN} \times D}{2 f_{SW} \times L}$$

### Input Capacitor

In boost converter, input current flows continuously into the inductor; AC ripple component is only proportional to the rate of the inductor charging, thus, smaller value input capacitors may be used. Ensure the voltage rating of the input capacitor is suitable to handle the full supply range.

A capacitor with low ESR should be chosen to minimize heating effects and improve system efficiency.

### Output Capacitor

The output capacitor acts to smooth the output voltage and supplies load current directly during the conduction phase of the power switch. Output ripple voltage consists of the discharge of the output capacitor during the FET ton period and the voltage drop due to load current flowing through the ESR of the output capacitor. The ripple voltage is shown in following equation.

$$\Delta V_{OUT} = \frac{I_{OUT} \times D}{C_{OUT} \times f_{SW}} + I_{OUT} \times ESR$$

Assume a ceramic capacitor is used. The minimum capacitance needed for a given ripple can be estimated by following equation.

$$C_{OUT} = \frac{(V_{IN} - V_{OUT}) \times I_{OUT}}{V_{OUT} \times f_{SW} \times \Delta V_{OUT}}$$

### Output Rectifying Diode

Schottky diodes are the ideal choice for MAP3205 due to their low forward voltage drop and fast switching speed. Make sure that the diode has a voltage rating greater than the possible maximum output voltage. The diode conducts current only when the power switch is turned off.

### Loop Compensation

The MAP3205 controls in current mode. Current mode easily achieves compensation by consisting simple single pole from double pole that LC filter makes at voltage mode. In general, crossover frequency is selected from 1/3 ~ 1/6 range of the switching frequency. If  $f_c$  is large, there is possibility of oscillation to occur, although time response gets better.

On the other hand, if  $f_c$  is small, time response will be bad, while it has improved stability, which may cause over shoot or under shoot in abnormal condition.

### Layout Consideration

A gate drive signal output from GATE pin becomes noise source, which may cause malfunction of IC due to cross talk if placed by the side of an analog line. It is recommended to avoid placing the output line especially by the side of CS, ISET, VADIM. FSW, OVP, COMP as far as possible.

Physical Dimensions

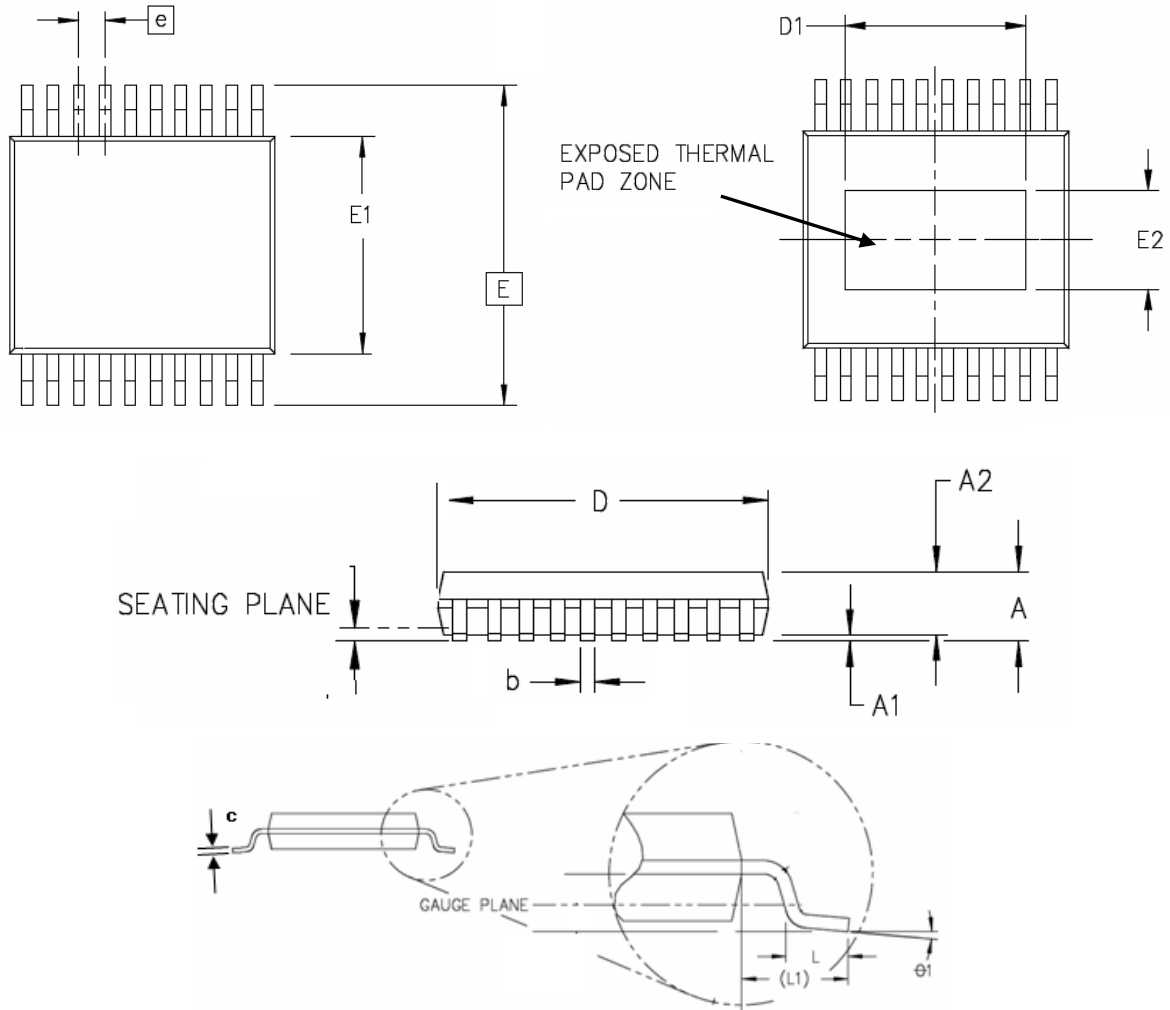

20 Leads TSSOP

Symbol	Dimension		
	Min	Norm	Max
A			1.20
A1	0.00		0.15
A2	0.80		1.05
b	0.19		0.30
c	0.09		0.20
D	6.40		6.60
D1	2.20		
E	6.40 BSC		
E1	4.30		4.50
E2	1.50		
e	0.65 BSC		
L	0.45		0.75
L1	1.00 REF		
θ	0°		8°

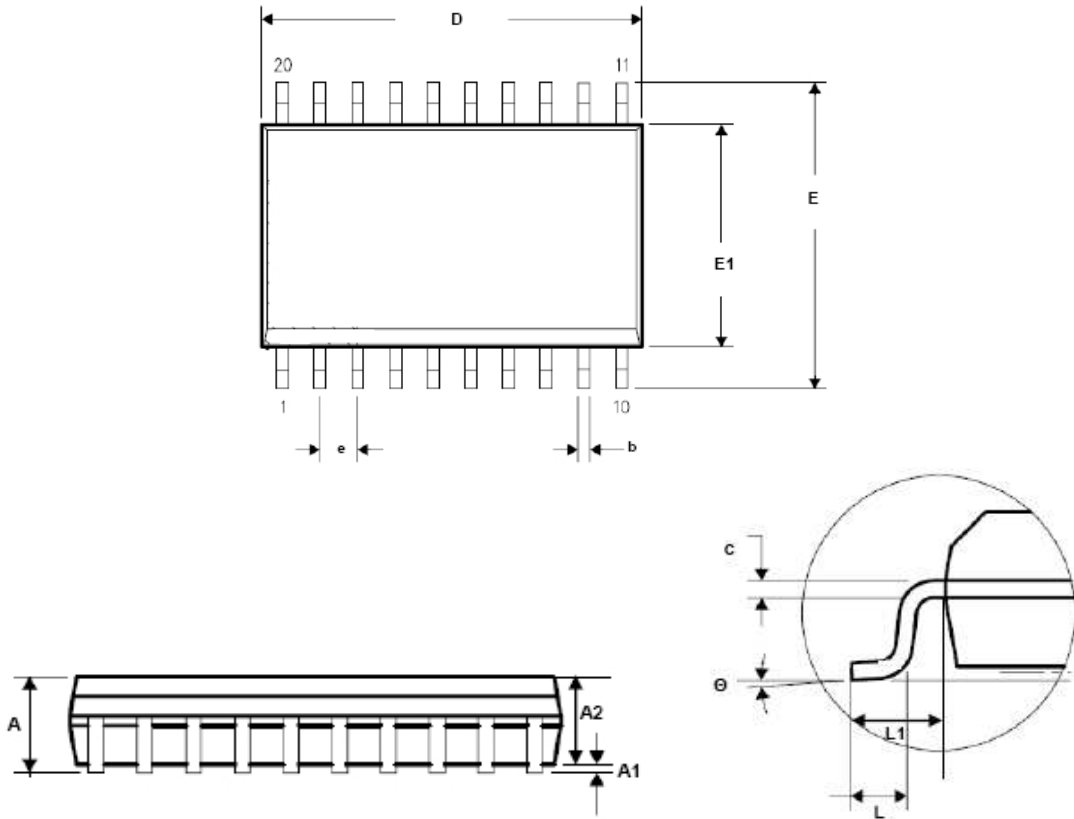

20 Leads SOIC

Symbol	Dimension		
	Min	Norm	Max
A			2.65
A1	0.05		0.30
A2	2.05		2.40
b	0.31		0.51
c	0.20		0.33
D	12.54		13.00
E			
E1	7.30		7.70
e		1.27 BSC	
L	0.40		1.27
L1		1.40 REF	
θ	0°		8°

MagnaChip Semiconductor Ltd. doesn't not recommend the use of its products in hostile environments, including, without limitation, aircraft, nuclear power generation, medical appliances, and devices or systems in which malfunction of any product can reasonably be expected to result in a personal injury. Seller's customers using or selling Seller's products for use in such applications do so at their own risk and agree to fully defend and indemnify Seller.

MagnaChip reserves the right to change the specifications and circuitry without notice at any time. MagnaChip does not consider responsibility for use of any circuitry other than circuitry entirely included in a MagnaChip product.

MagnaChip is a registered trademark of MagnaChip Semiconductor Ltd.

**MagnaChip Semiconductor Ltd.**

891, Daechi-Dong, Kangnam-Gu, Seoul, 135-738 Korea

Tel : 82-2-6903-3451 / Fax : 82-2-6903-3668 ~9

[www.magnachip.com](http://www.magnachip.com)

### Revision History

Date	Version	Changes
2011-10-21	Version 1.0	Initial release