

# RF Power Field Effect Transistor

## LDMOS, 2110 — 2170 MHz, 90W, 28V

4/6/2005

Preliminary

MAPLST2122-090CF

### Features

- Designed for W-CDMA base station applications in the 2.1 to 2.2 GHz Frequency Band. Suitable for TDMA, CDMA, W-CDMA and multicarrier power amplifier applications.
- 90W Output Power at  $P_{1dB}$  (CW)
- 11dB Minimum Gain at  $P_{1dB}$  (CW)
- W-CDMA Typical Performance: (28V<sub>DC</sub>, -45dB ACPR @ 4.096MHz)
  - Output Power: 12W (typ.)
  - Gain: 12dB (typ.)
  - Efficiency: 16% (typ.)
- 10:1 VSWR Ruggedness (CW @ 60W, 28V, 2110MHz)

### Package Style

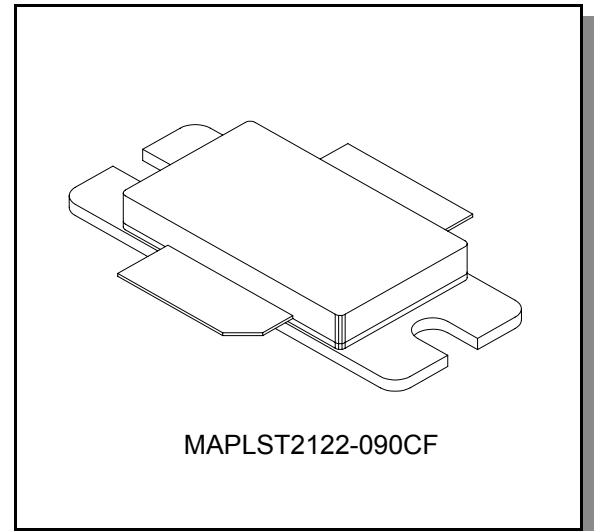

### Maximum Ratings

Parameter	Symbol	Rating	Units
Drain—Source Voltage	$V_{DSS}$	65	V <sub>dc</sub>
Gate—Source Voltage	$V_{GS}$	20	V <sub>dc</sub>
Drain Current — Continuous	$I_D$	20	A <sub>dc</sub>
Total Power Dissipation @ T <sub>c</sub> = 25 °C	$P_D$	206	W
Storage Temperature	T <sub>STG</sub>	-40 to +150	°C
Junction Temperature	T <sub>J</sub>	+200	°C

### Thermal Characteristics

Characteristic	Symbol	Max	Unit
Thermal Resistance, Junction to Case	R <sub>θJC</sub>	0.85	°C/W

**NOTE—CAUTION**—MOS devices are susceptible to damage from electrostatic charge. Precautions in handling and packaging MOS devices should be observed.

Preliminary

Characteristic	Symbol	Min	Typ	Max	Unit
<b>DC CHARACTERISTICS @ 25°C</b>					
Drain-Source Breakdown Voltage ( $V_{GS} = 0$ Vdc, $I_D = 100$ $\mu$ Adc)	$V_{(BR)DSS}$	65	—	—	Vdc
Zero Gate Voltage Drain Leakage Current ( $V_{DS} = 28$ Vdc, $V_{GS} = 0$ )	$I_{DSS}$	—	—	1	$\mu$ Adc
Gate—Source Leakage Current ( $V_{GS} = 5$ Vdc, $V_{DS} = 0$ )	$I_{GSS}$	—	—	1	$\mu$ Adc
Gate Threshold Voltage ( $V_{DS} = 10$ Vdc, $I_D = 60$ mA)	$V_{GS(th)}$	2	2.6	4	Vdc
Gate Quiescent Voltage ( $V_{DS} = 28$ Vdc, $I_D = 750$ mA)	$V_{DS(Q)}$	3	—	5	Vdc
Drain-Source On-Voltage ( $V_{GS} = 10$ Vdc, $I_D = 1$ A)	$V_{DS(on)}$	—	TBD	—	Vdc
Forward Transconductance ( $V_{GS} = 10$ Vdc, $I_D = 1$ A)	Gm	—	4.0	—	S
<b>DYNAMIC CHARACTERISTICS @ 25°C</b>					
Output Capacitance ( $V_{DS} = 28$ Vdc, $V_{GS} = 0$ , $f = 1$ MHz)	$C_{oss}$	—	98	—	pF
Reverse Transfer Capacitance ( $V_{DS} = 28$ Vdc, $V_{GS} = 0$ , $f = 1$ MHz)	$C_{rss}$	—	4.5	—	pF
<b>RF FUNCTIONAL TESTS @ 25°C (In M/A-COM Test Fixture)</b>					
Two-Tone Common-Source Amplifier Power Gain ( $V_{DS} = 28$ Vdc, $P_{OUT} = 90$ W PEP, $I_{DQ} = 750$ mA, $f_1 = 2140.0$ MHz, $f_2 = 2140.1$ MHz)	$G_{ps}$	—	11	—	dB
Two-Tone Drain Efficiency ( $V_{DS} = 28$ Vdc, $P_{OUT} = 90$ W PEP, $I_{DQ} = 750$ mA, $f_1 = 2140.0$ MHz, $f_2 = 2140.1$ MHz)	EFF ( $\eta$ )	—	33	—	%
Two-Tone Common-Source Amplifier Intermodulation ( $V_{DS} = 28$ Vdc, $P_{OUT} = 90$ W PEP, $I_{DQ} = 750$ mA, $f_1 = 2140.0$ MHz, $f_2 = 2140.1$ MHz)	IMD	—	-30	—	dBc
Input Return Loss ( $V_{DS} = 28$ Vdc, $P_{OUT} = 90$ W PEP, $I_{DQ} = 750$ mA, $f_1 = 2140.0$ MHz, $f_2 = 2140.1$ MHz)	IRL	—	-13	—	dB
Two-Tone Common-Source Amplifier Power Gain ( $V_{DS} = 28$ Vdc, $P_{OUT} = 90$ W PEP, $I_{DQ} = 750$ mA, $f_1 = 2110.0$ MHz, $f_2 = 2110.1$ MHz and $f_1 = 2170.0$ MHz, $f_2 = 2170.1$ MHz)	$G_{ps}$	—	11	—	dB
Two-Tone Drain Efficiency ( $V_{DS} = 28$ Vdc, $P_{OUT} = 90$ W PEP, $I_{DQ} = 750$ mA, $f_1 = 2110.0$ MHz, $f_2 = 2110.1$ MHz and $f_1 = 2170.0$ MHz, $f_2 = 2170.1$ MHz)	EFF ( $\eta$ )	—	33	—	%
Two-Tone Common-Source Amplifier Intermodulation ( $V_{DS} = 28$ Vdc, $P_{OUT} = 90$ W PEP, $I_{DQ} = 750$ mA, $f_1 = 2110.0$ MHz, $f_2 = 2110.1$ MHz and $f_1 = 2170.0$ MHz, $f_2 = 2170.1$ MHz)	IMD	—	-30	—	dBc
Input Return Loss ( $V_{DS} = 28$ Vdc, $P_{OUT} = 90$ W PEP, $I_{DQ} = 750$ mA, $f_1 = 2110.0$ MHz, $f_2 = 2110.1$ MHz and $f_1 = 2170.0$ MHz, $f_2 = 2170.1$ MHz)	IRL	—	-13	-9	dB
Output VSWR Tolerance ( $V_{DD} = 28$ Vdc, $P_{OUT} = 90$ W PEP, $I_{DQ} = 750$ mA, $f_1 = 2110.0$ MHz, $f_2 = 2110.1$ MHz, VSWR = 10:1, All Phase Angles at Frequency of Tests)	$\Psi$	No Degradation In Output Power Before and After Test			

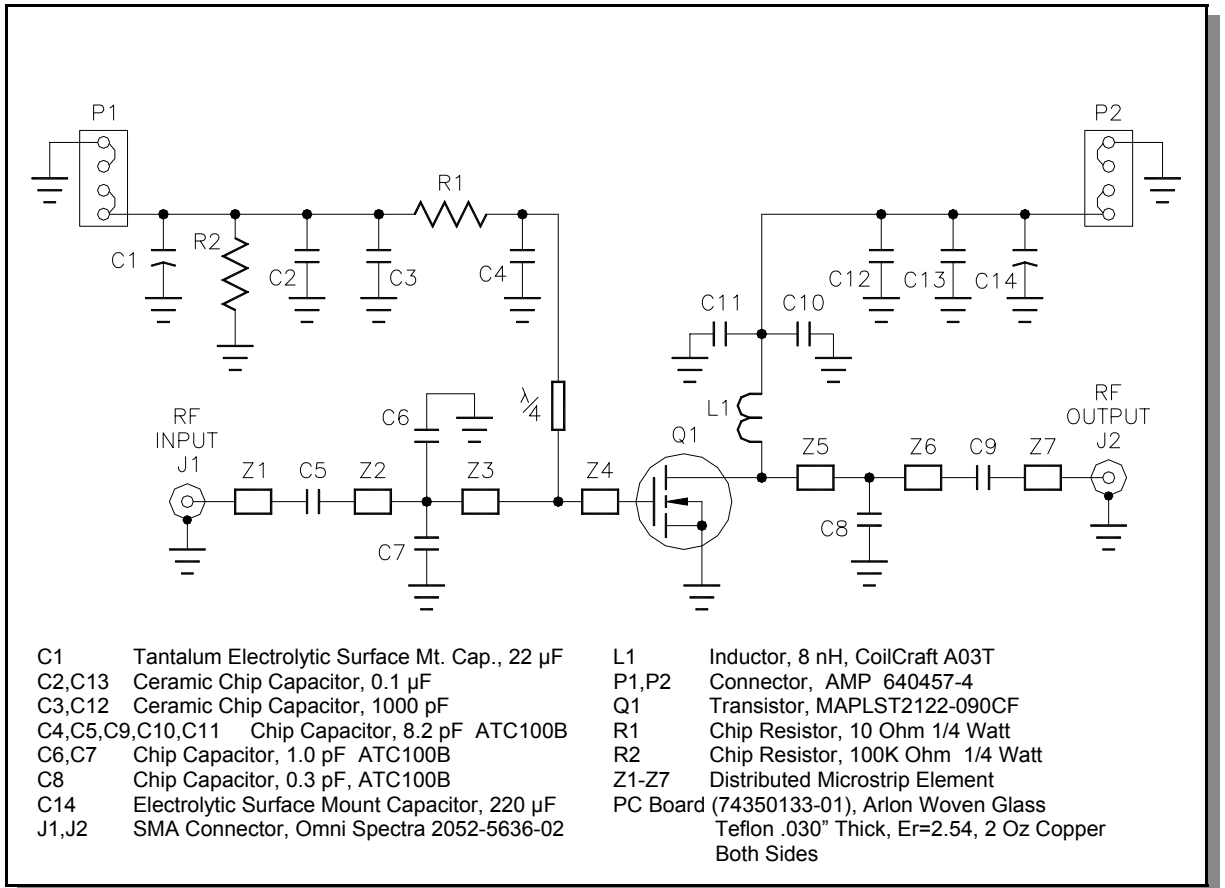

Figure 1. 2110—2170 MHz Test Fixture Schematic

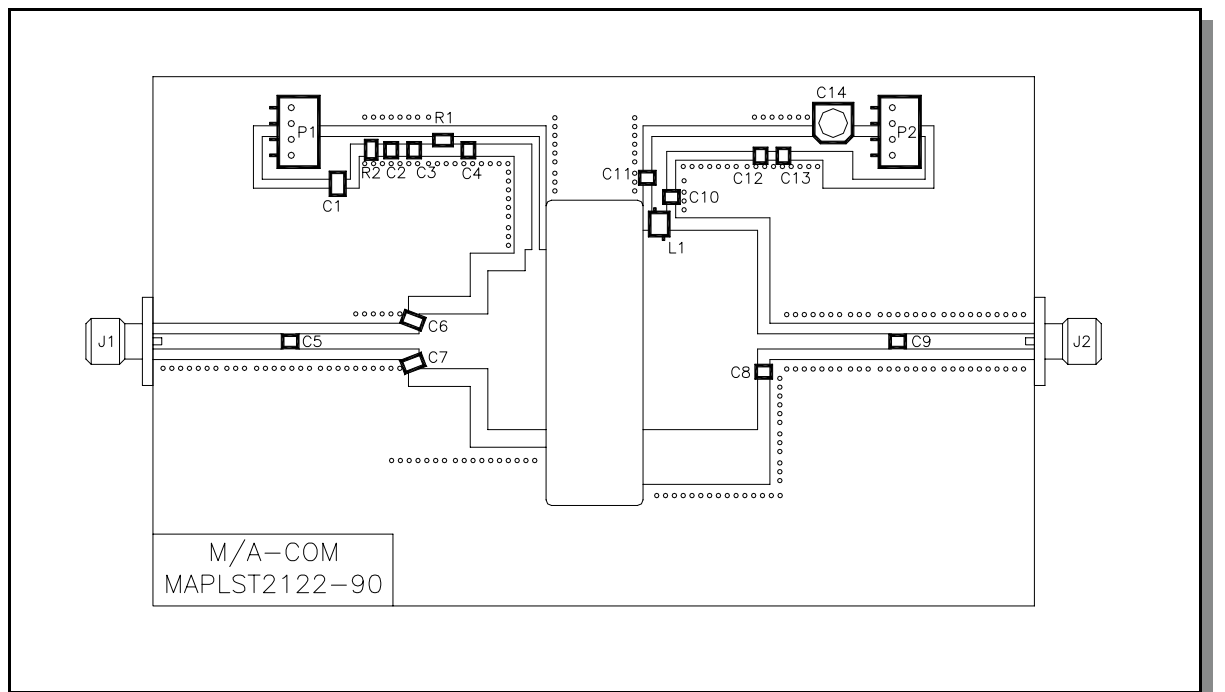
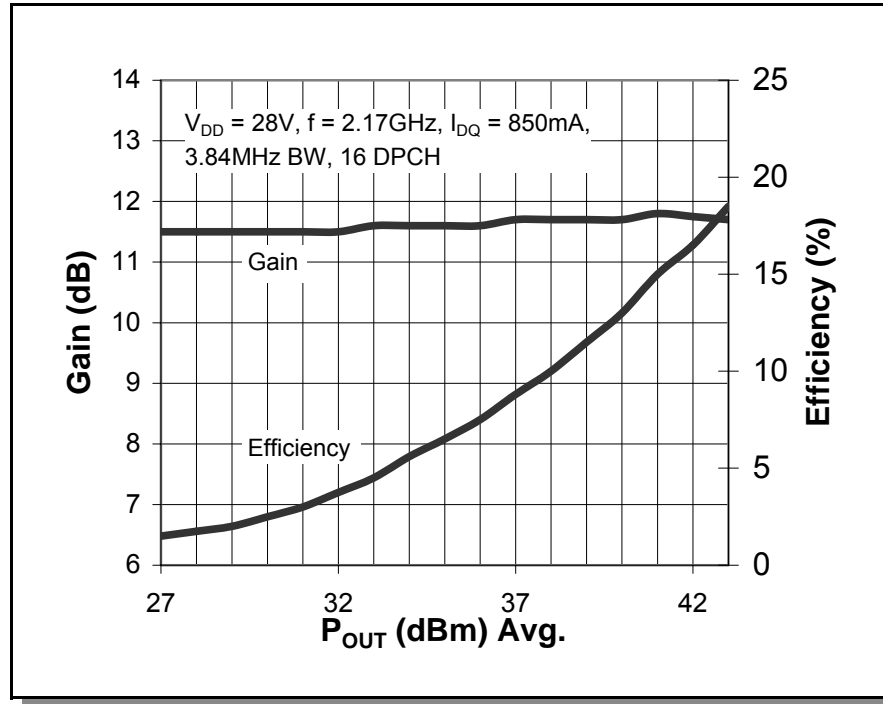
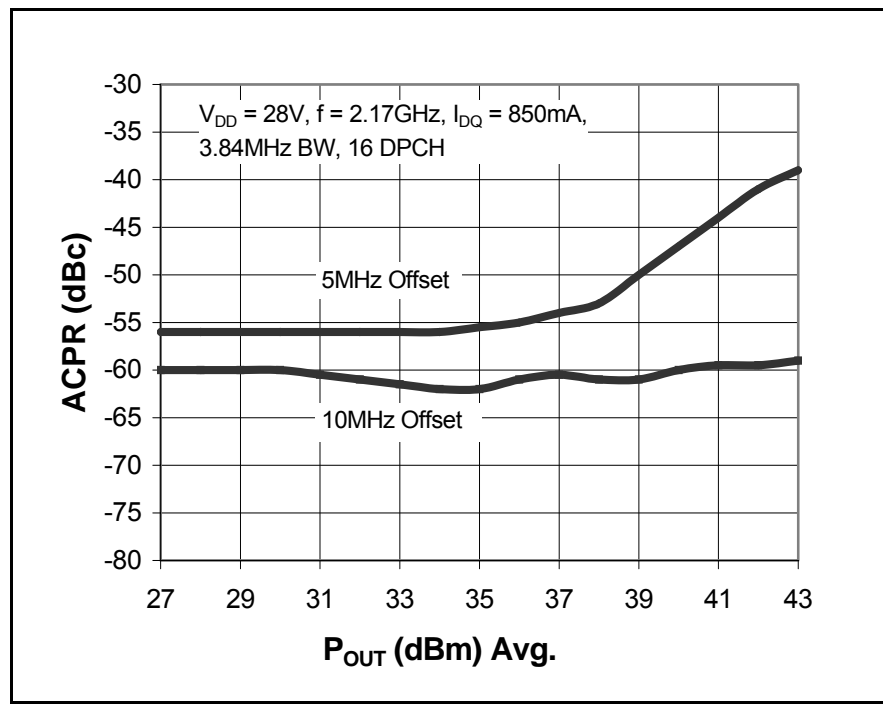

Figure 2. 2110—2170 MHz Test Fixture Component Layout



Graph 1. W-CDMA: Power Gain and Drain Efficiency vs. Output Power



Graph 2. W-CDMA: Adjacent Channel Power Ratio vs. Output Power

Package Dimensions

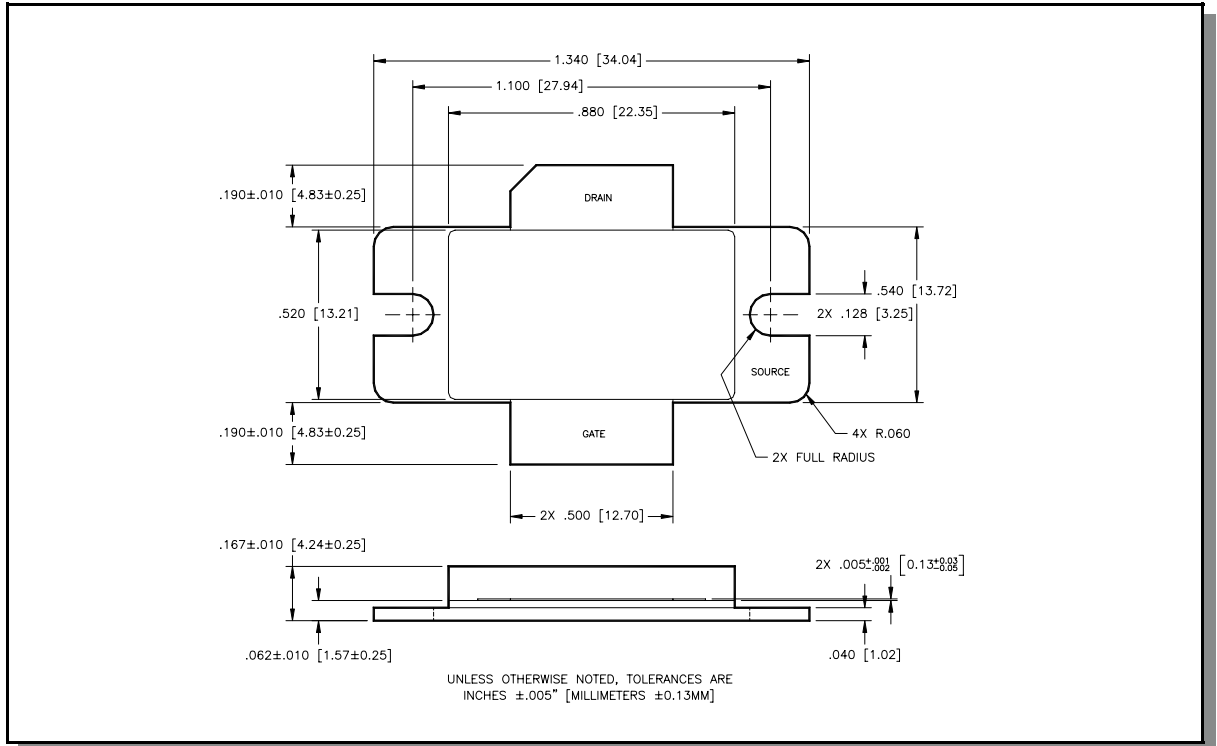

M/A-COM Inc. and its affiliates reserve the right to make changes to the product(s) or information contained herein without notice. M/A-COM makes no warranty, representation or guarantee regarding the suitability of its products for any particular purpose, nor does M/A-COM assume any liability whatsoever arising out of the use or application of any product(s) or information.

Visit [www.macom.com](http://www.macom.com) for additional data sheets and product information.

- North America: Tel. (800) 366-2266
- Asia/Pacific: Tel.+81-44-844-8296, Fax +81-44-844-8298
- Europe: Tel. +44 (1344) 869 595, Fax+44 (1344) 300 020