

MAS9012**Stepper Motor Driver IC**

- **Supports Microstepping Movement**
- **Capable to Drive One to Four Motors**
- **Low Operating Voltage**

DESCRIPTION

MAS9012 is a Miniature Stepper Motor Driver IC with four different versions to drive one to four motors of pointers in motorcycle and car dashboards and other similar applications. It features a microstepping function to allow smooth movement of the motor shaft. One microstep corresponds to an angular rotation of 1/12 degree

of the motor shaft. The actual precision of the position is affected by the gear play of the motor.

The microstepping movement of the motor shaft is achieved by converting a pulse sequence into a current level sequence sent to the stepper motor coils.

FEATURES

- Bipolar Stepper Motor Driver Outputs
- Drives One to Four Stepper Motors
- Microstepping Function
- Glitch Filters at All Inputs
- Low Operating Voltage
- TSSOP-16 and TSSOP-28 Packages

APPLICATIONS

- Motorcycle Dashboards
- Car Dashboards
- Nautical Instrumentation
- Miniature Stepper Motors in Appliances

BLOCK DIAGRAMS

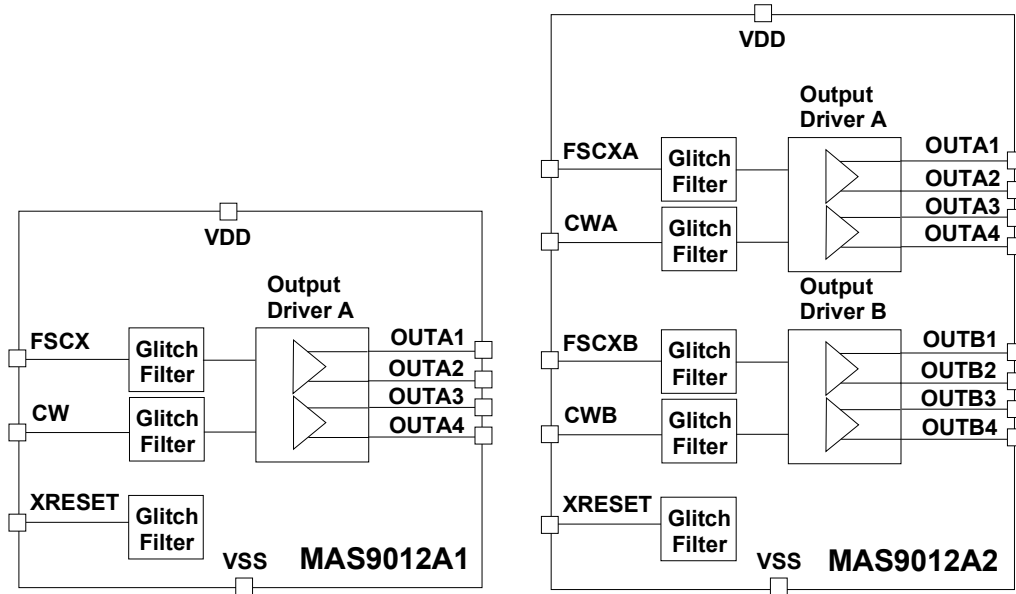

Figure 1. Block diagrams of single and dual output stepper motor driver ICs MAS9012A1 and MAS9012A2

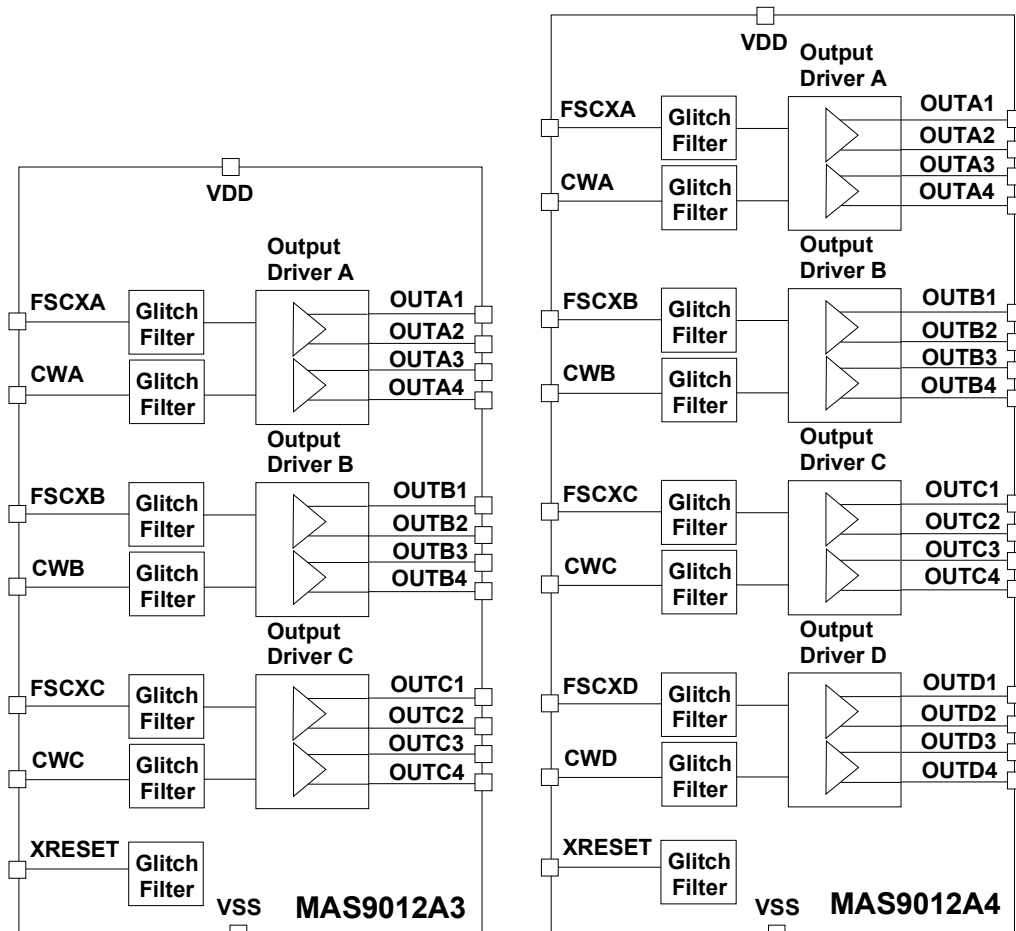

Figure 2. Block diagrams of triple and quad output stepper motor driver ICs MAS9012A3 and MAS9012A4

OPERATION DESCRIPTION

MAS9012 is a stepper motor driver IC specifically designed to drive bipolar stepper motors of pointers in a car and motorcycle dashboard and in the other similar applications. It has four different device versions: A1, A2, A3 and A4 with single, dual, triple and quad stepper motor driver outputs respectively (see block diagrams on page 2).

The IC is operated from single 5V supply. Each stepper motor output is controlled by two digital control signal inputs, FSCX and CW. Each rising edge of FSCX stepping clock input causes stepper motor to step one microstep (1/12 degree) ahead. Rotation direction is determined by CW rotation direction selection signal. High CW selects

clockwise direction and low CW selects counterclockwise direction. Each stepper motor has its own FSCX and CW signal inputs.

The device has common XRESET master reset control input for resetting stepper motor outputs to initial state. XRESET is active low. Each digital input has a glitch filter for eliminating effects of electrical disturbances at the control inputs.

It is recommended to keep XRESET signal low (active) during power up until the supply voltage VDD has risen up.

ABSOLUTE MAXIMUM RATINGS

All voltages with respect to ground

Parameter	Symbol	Conditions	Min	Max	Unit
Supply Voltage	V_{IN}		-0.3	6	V
Voltage Range for All Pins			-0.3	$V_{IN} + 0.3$	V
ESD Rating		HBM		2	kV
Junction Temperature	T_{Jmax}			+175 (limited)	°C
Storage Temperature	T_S		-55	+150	°C

Stresses beyond those listed may cause permanent damage to the device. The device may not operate under these conditions, but it will not be destroyed.

RECOMMENDED OPERATING CONDITIONS

Parameter	Symbol	Conditions	Min	Typ	Max	Unit
Operating Supply Voltage	V_{DD}		4.5	5.0	5.5	V
Operating Junction Temperature	T_J		-40		+125	°C
Operating Ambient Temperature	T_A		-40		+85	°C

ELECTRICAL CHARACTERISTICS

◆ Load Characteristics

Parameter	Symbol	Conditions	Min	Typ	Max	Unit
Coil resistance	R_{COIL}	$T_A = 25^\circ\text{C}$		290		Ohm
Phase inductance	L_{COIL}	$T_A = 25^\circ\text{C}$		0.4		H

◆ Current Parameters

$T_A = -40^\circ\text{C}$ to $+85^\circ\text{C}$, typical values at $T_A = +25^\circ\text{C}$, $R_{COIL} = 290 \Omega$, $V_{DD} = 5.0 \text{ V}$, unless otherwise specified

Parameter	Symbol	Conditions	Min	Typ	Max	Unit
Quiescent current	I_{CC}	All inputs at VDD or VSS, no load (Quad output driver version)			300	μA
Typical supply current consumption	I_C	Quad output driver version		76		mA
Output drive capability	I_{OUT}	For each output pin			29	mA

ELECTRICAL CHARACTERISTICS...

◆ Digital Inputs

$T_A = -40^{\circ}\text{C}$ to $+85^{\circ}\text{C}$, typical values at $T_A = +25^{\circ}\text{C}$, $V_{DD}=5.0\text{ V}$, unless otherwise specified

Parameter	Symbol	Conditions	Min	Typ	Max	Unit
Input High Voltage	V_{IH}	$V_{DD} = 4.5\dots 5.5\text{V}$	80% VDD		100% VDD	V
Input Low Voltage	V_{IL}	$V_{DD} = 4.5\dots 5.5\text{V}$	0% VDD		20% VDD	V
Input frequency	f_{IN}				15	kHz

◆ Power Dissipation

$T_A = -40^{\circ}\text{C}$ to $+85^{\circ}\text{C}$, typical values at $T_A = +25^{\circ}\text{C}$, $V_{DD}=5.0\text{ V}$, unless otherwise specified

Parameter	Symbol	Conditions	Min	Typ	Max	Unit
Junction to Ambient Thermal Resistance	R_{JA}	typical PC board mounting, still air, TSSOP package		100.4		$^{\circ}\text{C}/\text{W}$
Maximum Power Dissipation	P_d	any ambient temperature, TSSOP package	$P_{dMAX} = \frac{T_{J(MAX)} - T_A}{R_{JA}}$ Note 1			W

Note 1: $T_{J(MAX)}$ denotes maximum operating junction temperature ($+125^{\circ}\text{C}$), T_A ambient temperature, and R_{JA} junction-to-air thermal resistance ($+144^{\circ}\text{C}/\text{W}$).

◆ Timing Characteristics

$T_A = -40^{\circ}\text{C}$ to $+85^{\circ}\text{C}$, $V_{DD} = 5.0\text{ V}$, unless otherwise specified

Parameter	Symbol	Conditions	Min	Typ	Max	Unit
Signal pulse width		High or low				ns
Signal pulse width	t_w	High or low	450			ns
Setup time to f(SCX)	t_s	High or low	100			ns
XRESET release time to f(SCX)	t_{RR}		100			ns

◆ Delay Timing Waveforms

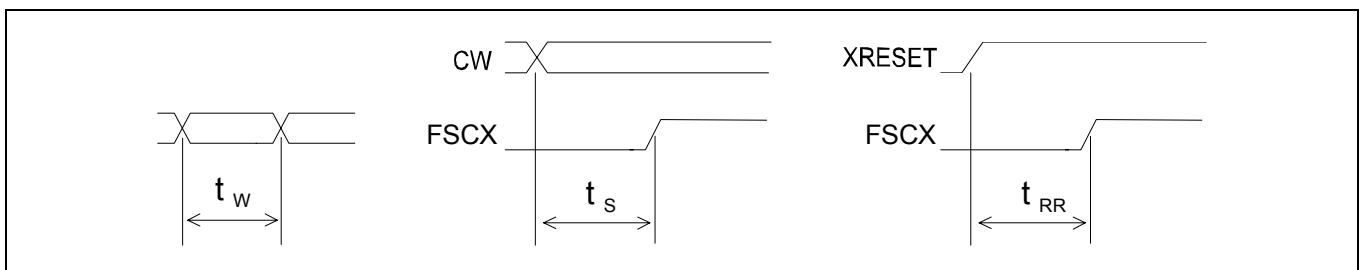

APPLICATION INFORMATION

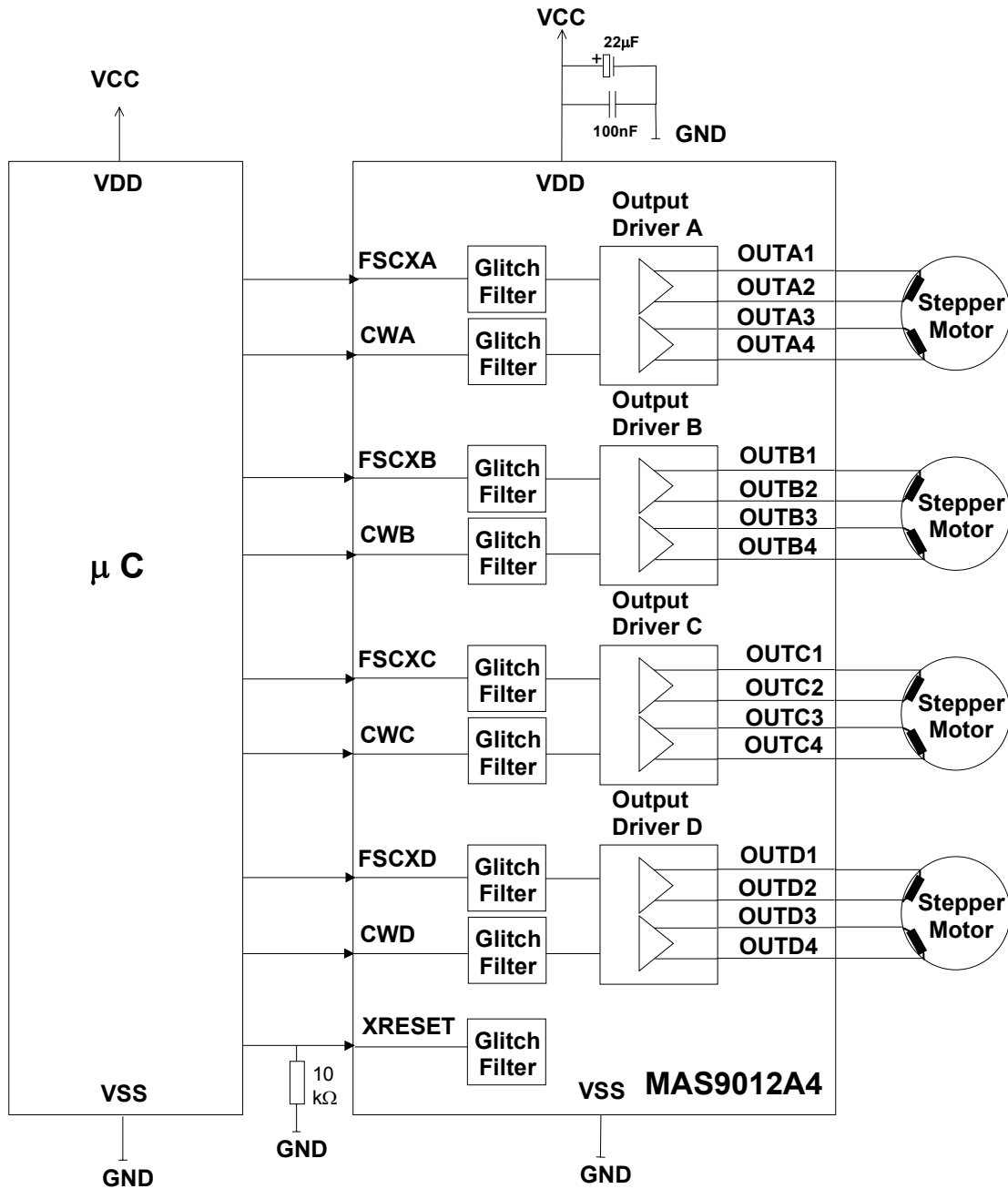
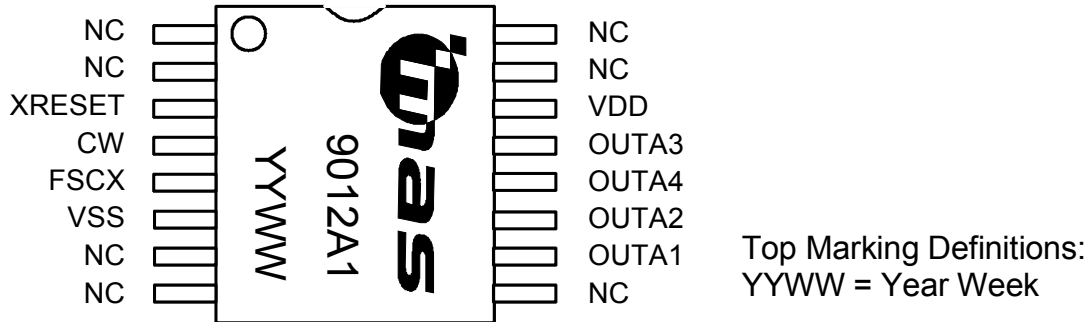

Figure 3. Typical MAS9012A4 quad stepper motor driver application circuit

The supply voltages of MAS9012 can be decoupled with parallel connection of 22 μ F and 100 nF decoupling capacitors (see figure 3).

MAS9012A1 SINGLE OUTPUT DRIVER PIN CONFIGURATION IN PLASTIC TSSOP-16



PIN DESCRIPTION

Pin Name	Pin	Type	Function
	1	NC	
	2	NC	
XRESET	3	DI	Master Reset, active low
CW	4	DI	Rotation Direction Selection, High = Clockwise, Low = Counterclockwise
FSCX	5	DI	Stepping Clock Input
VSS	6	G	Power Supply Ground
	7	NC	
	8	NC	
	9	NC	
OUTA1	10	AO	Stepper Motor Driver A Coil Output 1
OUTA2	11	AO	Stepper Motor Driver A Coil Output 2
OUTA4	12	AO	Stepper Motor Driver A Coil Output 4
OUTA3	13	AO	Stepper Motor Driver A Coil Output 3
VDD	14	P	Positive Power Supply
	15	NC	
	16	NC	

A = Analog, D = Digital, P = Power, G = Ground, I = Input, O = Output, NC = Not Connected

MAS9012A2 DUAL OUTPUT DRIVER PIN CONFIGURATION IN PLASTIC TSSOP-16

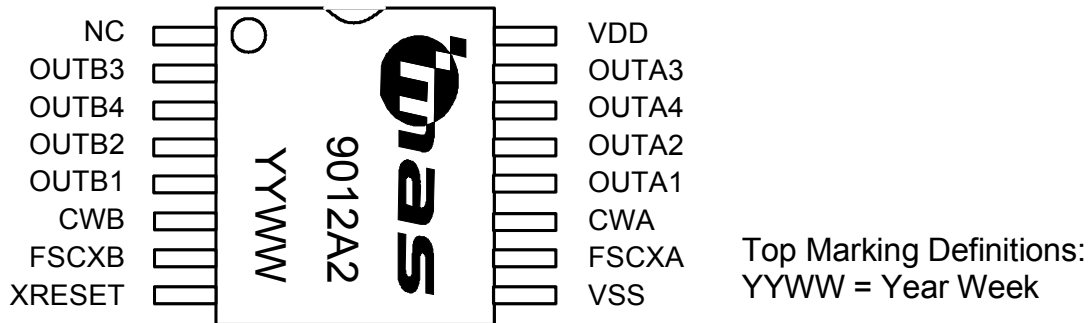

PIN DESCRIPTION

Pin Name	Pin	Type	Function
	1	NC	
OUTB3	2	AO	Stepper Motor Driver B Coil Output 3
OUTB4	3	AO	Stepper Motor Driver B Coil Output 4
OUTB2	4	AO	Stepper Motor Driver B Coil Output 2
OUTB1	5	AO	Stepper Motor Driver B Coil Output 1
CWB	6	DI	Rotation Direction Selection B, High = Clockwise, Low = Counterclockwise
FSCXB	7	DI	Stepping Clock Input B
XRESET	8	DI	Master Reset, active low
VSS	9	G	Power Supply Ground
FSCAXA	10	DI	Stepping Clock Input A
CWA	11	DI	Rotation Direction Selection A, High = Clockwise, Low = Counterclockwise
OUTA1	12	AO	Stepper Motor Driver A Coil Output 1
OUTA2	13	AO	Stepper Motor Driver A Coil Output 2
OUTA4	14	AO	Stepper Motor Driver A Coil Output 4
OUTA3	15	AO	Stepper Motor Driver A Coil Output 3
VDD	16	P	Positive Power Supply

A = Analog, D = Digital, P = Power, G = Ground, I = Input, O = Output, NC = Not Connected

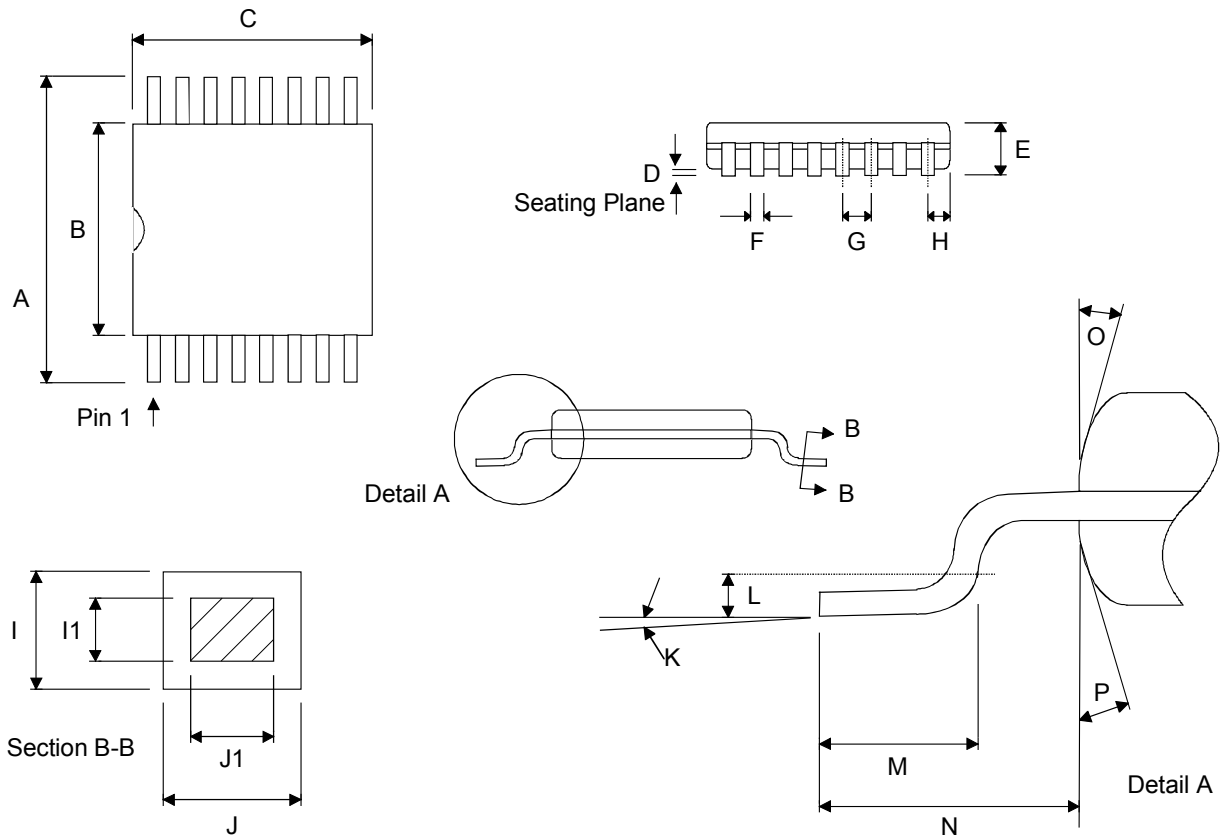
PACKAGE (TSSOP16) OUTLINES

Dimension	Min	Max	Unit
A	6.40 BSC		mm
B	4.30	4.50	mm
C	5.00 BSC		mm
D	0.05	0.15	mm
E		1.10	mm
F	0.19	0.30	mm
G	0.65 BSC		mm
H	0.18	0.28	mm
I	0.09	0.20	mm
I1	0.09	0.16	mm
J	0.19	0.30	mm
J1	0.19	0.25	mm
K	0°	8°	
L	0.24	0.26	mm
M	0.50	0.75	mm
(The length of a terminal for soldering to a substrate)			
N	1.00 REF		mm
O	12°		
P	12°		

Dimensions do not include mold flash, protrusions, or gate burrs.
 All dimensions are in accordance with JEDEC standard MO-153.

SOLDERING INFORMATION

Resistance to Soldering Heat	According to RSH test IEC 68-2-58/20 2*220°C
Maximum Temperature	240°C
Maximum Number of Reflow Cycles	3
Reflow profile	Thermal profile parameters stated in JESD22-A113 should not be exceeded. http://www.jedec.org
Seating Plane Co-planarity	max 0.08 mm
Lead Finish	Solder plate 7.62 - 25.4 μm, material Sn 85% Pb 15%

EMBOSSED TAPE SPECIFICATIONS (TSSOP16)

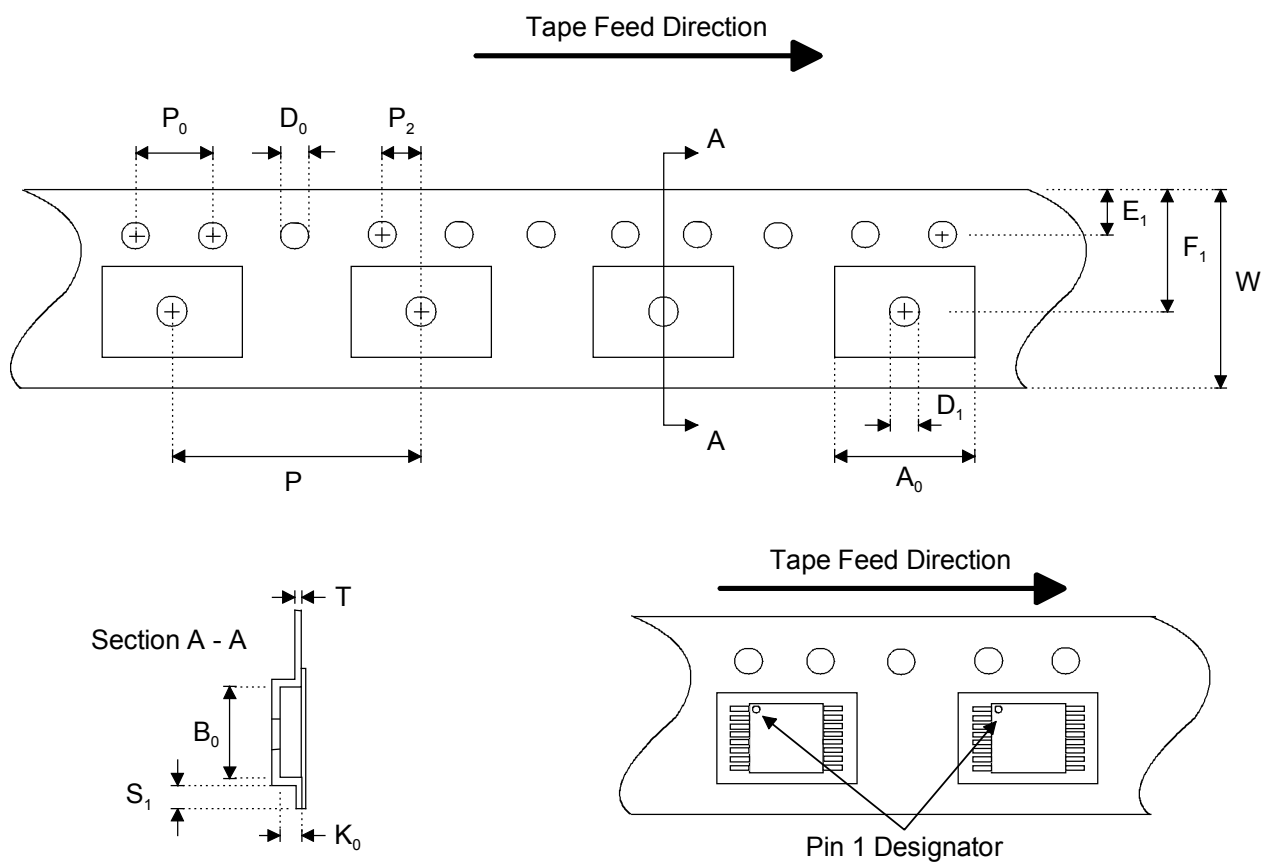

Dimension	Min	Max	Unit
A_0	6.50	6.70	mm
B_0	5.20	5.40	mm
D_0	1.50 +0.10 / -0.00		mm
D_1	1.50		mm
E_1	1.65	1.85	mm
F_1	7.20	7.30	mm
K_0	1.20	1.40	mm
P	11.90	12.10	mm
P_0	4.0		mm
P_2	1.95	2.05	mm
S_1	0.6		mm
T	0.25	0.35	mm
W	11.70	12.30	mm

REEL SPECIFICATIONS (TSSOP16)

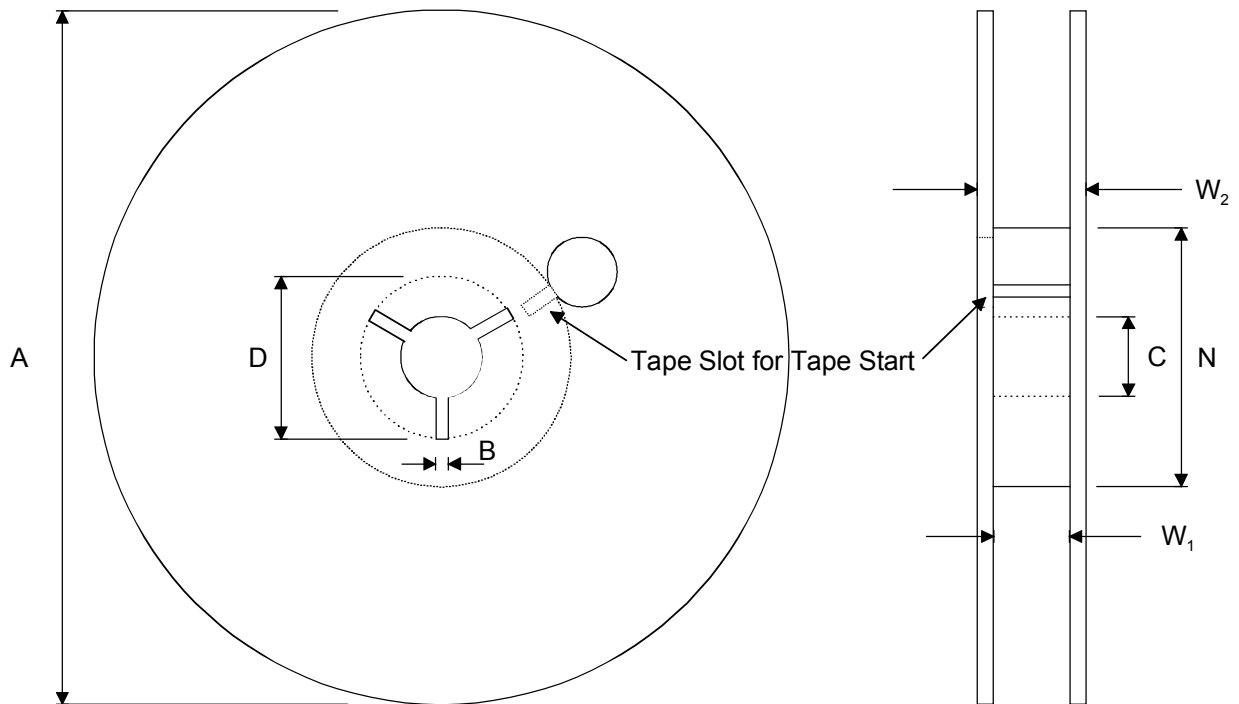

2000 Components on Each Reel

Reel Material: Conductive, Plastic Antistatic or Static Dissipative

Carrier Tape Material: Conductive

Cover Tape Material: Static Dissipative

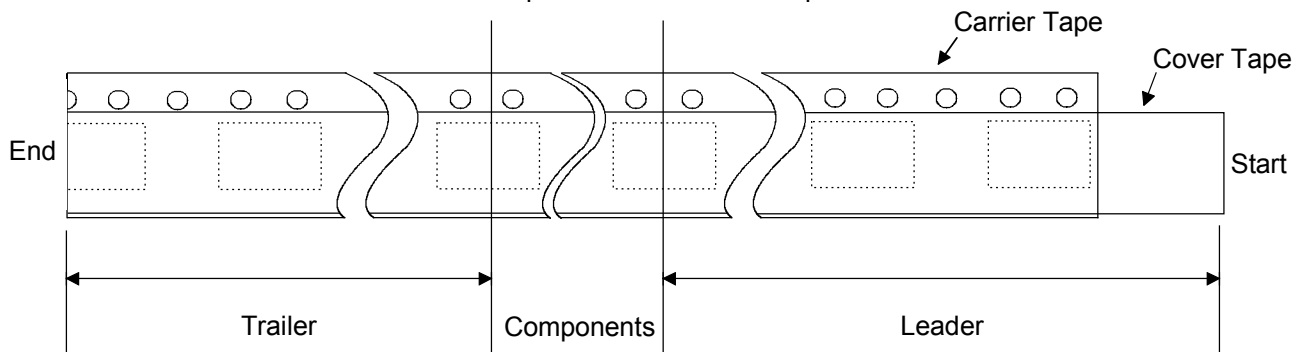

Dimension	Min	Max	Unit
A		330	mm
B	1.5		mm
C	12.80	13.50	mm
D	20.2		mm
N	50		mm
W_1 (measured at hub)	12.4	14.4	mm
W_2 (measured at hub)		18.4	mm
Trailer	160		mm
Leader	390, of which minimum 160 mm of empty carrier tape sealed with cover tape		mm
Weight		1500	g

ORDERING INFORMATION

Product Code	Product	Package	Comments
MAS9012A1UA06	Single Output Stepper Motor Driver IC	TSSOP-16	Tape and Reel, 2000 pcs/reel
MAS9012A2UA06	Dual Output Stepper Motor Driver IC	TSSOP-16	Tape and Reel, 2000 pcs/reel
MAS9012A3UA06	Triple Output Stepper Motor Driver IC	TSSOP-24	Tape and Reel
MAS9012A4UA06	Quad Output Stepper Motor Driver IC	TSSOP-28	Tape and Reel

LOCAL DISTRIBUTOR

--

MICRO ANALOG SYSTEMS OY CONTACTS

Micro Analog Systems Oy Kamreerintie 2, P.O. Box 51 FIN-02771 Espoo, FINLAND	Tel. +358 9 80 521 Fax +358 9 805 3213 http://www.mas-oy.com
--	--

NOTICE

Micro Analog Systems Oy reserves the right to make changes to the products contained in this data sheet in order to improve the design or performance and to supply the best possible products. Micro Analog Systems Oy assumes no responsibility for the use of any circuits shown in this data sheet, conveys no license under any patent or other rights unless otherwise specified in this data sheet, and makes no claim that the circuits are free from patent infringement. Applications for any devices shown in this data sheet are for illustration only and Micro Analog Systems Oy makes no claim or warranty that such applications will be suitable for the use specified without further testing or modification.