

**HMIC™ PIN Diode SP2T 8 Watt Switch  
for 0.05 – 6.0 GHz Higher Power Applications**

**MASW-000822-12770T  
Rev 1.0**

**Features**

- Exceptional Broadband Performance, 0.05 - 6.0 GHz
- Lower Loss: Tx = 0.35 dB, Rx = 0.55 dB @ 3.8 GHz, 20mA
- Higher Isolation: Rx-Tx = 21dB, Tx-Rx = 26dB @ 3.8 GHz
- Higher RF Input Power = 8 W C.W ( Tx-Ant Port )
- Higher IIP3 = 65 dBm ( Tx-Ant Port )
- Lower EVM (OFDM): < 1.0% @ 8W Pinc, ( Tx-Ant Port )
- Suitable for Higher Power WiMAX & WiFi Applications
- Surface Mount 3mm MLP Package, RoHS Compliant

**Description and Applications**

The MA-COM MASW-000822-12770T is a SP2T Broadband, high linearity, common anode, PIN diode T/R switch for 0.05 - 6.0 GHz applications, including WiMAX & WiFi. The device is provided in industry standard 3mm MLP plastic packaging. This device incorporates a PIN diode die fabricated with M/A-COM's patented Silicon-Glass HMIC™ process. This chip features two silicon pedestals embedded in a low loss, low dispersion glass. The diodes are formed on the top of each pedestal. The topside is fully encapsulated with silicon nitride and has an additional polymer passivation layer. These polymer protective coatings prevent damage and contamination during handling and assembly.

This compact 3mm MLP package, SP2T switch offers wideband 0.05 - 6.0 GHz performance with excellent isolation to loss ratio for both Tx and Rx states. The PIN diode provides exceptional 8 W C.W. power handling coupled with 65 dBm IIP3 for maximum switch performance.

**Absolute Maximum Ratings<sup>1</sup>**

**@ T<sub>A</sub> = +25 °C (unless otherwise specified)**

Parameter	Absolute Maximum
Forward Current	I 100 mA I
Reverse Voltage (RF & D.C.)	I -100 V I
Operating Temperature	-40 °C to +85 °C
Storage Temperature	-55 °C to +150 °C
Junction Temperature	+175 °C
Tx Incident C.W. Power	8 W C.W.
Tx Peak Incident Power	20 W, 3 uS P.W., 1% Duty
Mounting Temperature	+235 °C for 10 seconds

1. Exceeding these limits may cause permanent damage.

**Functional Diagram:**

**Common Anode Series PIN Diode Switch**

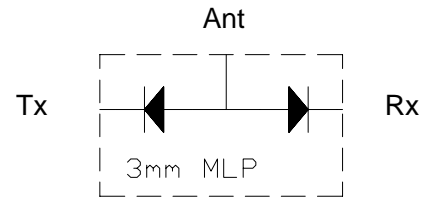

**3mm MLP Outline: OD-S 1277  
Circuit Side View**



**PIN Configuration:**

(Center Metal Area is RF, D.C., and Thermal Ground)

PIN	Function	PIN	Function
1	N/C	9	N/C
2	N/C	10	Rx
3	Tx	11	N/C
4	N/C	12	N/C
5	N/C	13	N/C
6	N/C	14	Ant
7	N/C	15	N/C
8	N/C	16	N/C

**Ordering Information**

Part Number	Package
MASW-000822-12770T	Tape and Reel

M/A-COM Inc. and its affiliates reserve the right to make changes to the product(s) or information contained herein without notice. M/A-COM makes no warranty, representation or guarantee regarding the suitability of its products for any particular purpose, nor does M/A-COM assume any liability whatsoever arising out of the use or application of any product(s) or information.

- **North America** Tel: 800.366.2266 / Fax: 978.366.2266
- **Europe** Tel: 44.1908.574.200 / Fax: 44.1908.574.300
- **Asia/Pacific** Tel: 81.44.844.8296 / Fax: 81.44.844.8298

Visit [www.macom.com](http://www.macom.com) for additional data sheets and product information.

**HMIC™ PIN Diode SP2T 8 Watt Switch  
for 0.05 – 6.0 GHz Higher Power Applications**

**MASW-000822-12770T  
Rev 1.0**

**Electrical Specifications @ +25 °C, Characteristic Impedance, Zo = 50 Ω**

Parameter	Symbol	Conditions	Units	Min	Typ	Max
<b>F = 2.3-2.7 GHz</b>						
Insertion Loss, Rx	Rx IL	Rx = +5.0 V@ +22mA, Tx =+12V @ 0mA, Pinc= 0 dBm	dB		0.52	0.70
Insertion Loss, Tx	Tx IL	Tx = +5.0 V@ +22mA, Rx =+12V @ 0mA, Pinc= 0 dBm	dB		0.35	0.45
Isolation, Tx To Rx	Rx ISO	Tx = +5.0 V@ +22mA, Rx =+12V @ 0mA, Pinc= 0 dBm	dB	27.0	29.5	
Isolation, Rx To Tx	Tx ISO	Rx = +5.0 V@ +22mA, Tx =+12V @ 0mA, Pinc= 0 dBm	dB	22.5	24.5	
Tx Input Return Loss	Tx RL	Tx = +5.0 V@ +22mA, Rx =+12V @ 0mA, Pinc= 0 dBm	dB		17	
Rx Input Return Loss	Rx RL	Rx = +5.0 V@ +22mA, Tx =+12V @ 0mA, Pinc= 0 dBm	dB		17	
<b>F = 3.3-3.8 GHz</b>						
Insertion Loss, Rx	Rx IL	Rx = +5.0 V@ +22mA, Tx =+12V @ 0mA, Pinc= 0 dBm	dB		0.55	0.75
Insertion Loss, Tx	Tx IL	Tx = +5.0 V@ +22mA, Rx =+12V @ 0mA, Pinc= 0 dBm	dB		0.35	0.55
Isolation, Tx To Rx	Rx ISO	Tx = +5.0 V@ +22mA, Rx =+12V @ 0mA, Pinc= 0 dBm	dB	24.5	26.5	
Isolation, Rx To Tx	Tx ISO	Rx = +5.0 V@ +22mA, Tx =+12V @ 0mA, Pinc= 0 dBm	dB	19.5	21.5	
Tx Input Return Loss	Tx RL	Tx = +5.0 V@ +22mA, Rx =+12V @ 0mA, Pinc= 0 dBm	dB		18	
Input Return Loss	Rx RL	Rx = +5.0 V@ +22mA, Tx =+12V @ 0mA, Pinc= 0 dBm	dB		18	
<b>F = 4.9-5.9 GHz</b>						
Insertion Loss, Rx	Rx IL	Rx = +5.0 V@ +22mA, Tx =+12V @ 0mA, Pinc= 0 dBm	dB		0.65	1.00
Insertion Loss, Tx	Tx IL	Tx = +5.0 V@ +22mA, Rx =+12V @ 0mA, Pinc= 0 dBm	dB		0.4	0.85
Isolation, Tx To Rx	Rx ISO	Tx = +5.0 V@ +22mA, Rx =+12V @ 0mA, Pinc= 0 dBm	dB	23.0	25.5	
Isolation, Rx To Tx	Tx ISO	Rx = +5.0 V@ +22mA, Tx =+12V @ 0mA, Pinc= 0 dBm	dB	17.5	20.0	
Tx Input Return Loss	Tx RL	Tx = +5.0 V@ +22mA, Rx =+12V @ 0mA, Pinc= 0 dBm	dB		18	
Rx Input Return Loss	Rx RL	Rx = +5.0 V@ +22mA, Tx =+12V @ 0mA, Pinc= 0 dBm	dB		18	

**HMIC™ PIN Diode SP2T 8 Watt Switch  
for 0.05 – 6.0 GHz Higher Power Applications**

**MASW-000822-12770T  
Rev 1.0**

**Electrical Specifications @ +25 °C, Characteristic Impedance, Zo = 50 Ω**

Parameter	Symbol	Conditions	Units	Min	Typ	Max
Tx Input P0.2dB	Tx IP0.2dB	3.5 GHz, Tx = +5.0 V@ +22mA, Rx =+12V @ 0mA Tx To Antenna	dBm		36	
Tx Input P1dB	Tx IP1dB	3.5 GHz, Tx = +5.0 V@ +22mA, Rx =+12V @ 0mA Tx To Antenna	dBm		40	
Tx 2 <sup>nd</sup> Harmonic	Tx 2Fo	3.5 GHz, Tx = +5.0 V@ +22mA, Rx =+12V @ 0mA Pin = + 30 dBm	dBc		68	
Tx 3 <sup>rd</sup> Harmonic	Tx 3Fo	3.5 GHz, Tx = +5.0 V@ +22mA, Rx =+12V @ 0mA Pin = + 30 dBm	dBc		84	
Tx Input Third Order Intercept Point	Tx IIP3	Tx = +5.0 V@ +22mA, Rx =+12V @ 0mA Pi= +10dBm, F1 = 3.500 GHz, F2 = 3.510 GHz	dBm		65	
Tx C.W. Input Power	Tx Pinc	Tx = +5.0 V@ +22mA, Rx =+12V @ 0mA F = 3.5 GHz	dBm			39
Rx C.W. Input Power	Rx Pinc	Rx = +5.0 V@ +22mA, Tx =+12V @ 0mA F = 3.5 GHz	dBm			30
Tx RF Switching Speed	τ <sub>RF</sub>	( 10-90% RF Voltage) Tx = +5.0 V@ +22mA, Rx =+12V @ 0mA 1MHz Rep Rate in Modulating Mode	us		1	
Tx EVM (OFDM)	EVM	Tx = +5.0 V@ +22mA, Rx =+12V @ 0mA Pinc = +39 dBm	%		0.8	

**Notes:**

1. Data is taken on M/A-COM evaluation board 1000029181-0000001 @ 25C by removing peripheral board losses ( connectors, transmission line, and bias elements ).
2. Typical PIN Diode Forward Voltage = + 0.9 V @ + 22 mA for Insertion Loss.  
Typical PIN Diode Reverse Voltage = 12 V – 0.9 V = 11.1 V for Isolation  
( See Bias Schematic Page 9 ).
3. Switch is Asymmetrical, + 39 dBm RF Input Power Applies to Tx Port Only.
4. Center Ground Area of MLP 3mm Package must be Attached to Thermal Ground for Optimum RF Power Performance.

**Assembly Note:**

A typical profile for a Sn 60/ Pb 40 Soldering process is provided in Application Note, “ M538 ” ,  
“ Surface Mounting Instructions ” on the MA-COM website [www.macom.com](http://www.macom.com)

HMIC™ PIN Diode SP2T 8 Watt Switch  
for 0.05 – 6.0 GHz Higher Power Applications

MASW-000822-12770T  
Rev 1.0

**MASW-000822-12770T Typical Performance Curves @ +25°C: Tx & Rx Insertion Loss**  
Bias Conditions: 10 mA and 20 mA for Low Loss , 11 V Back Bias for Isolation

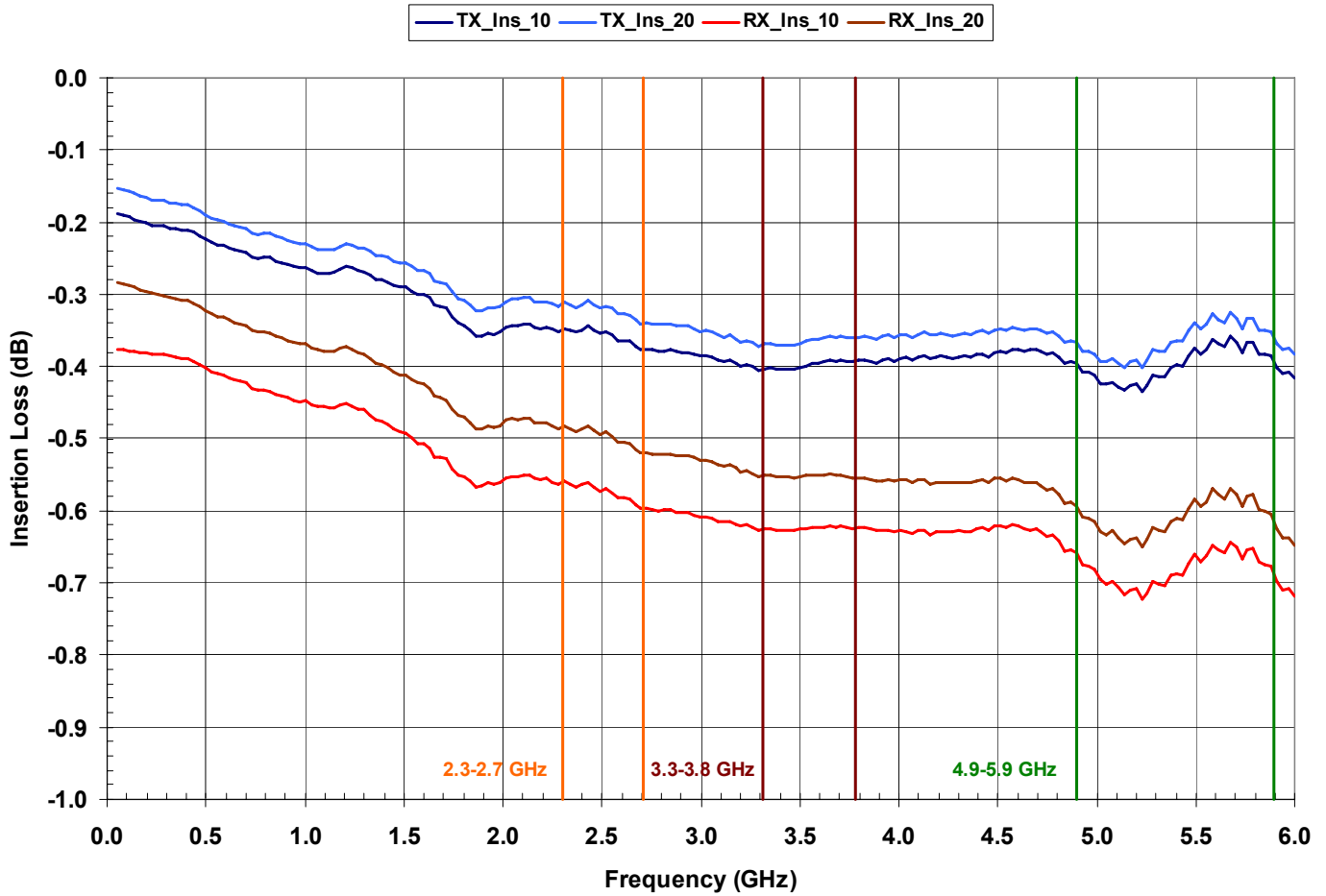

HMIC™ PIN Diode SP2T 8 Watt Switch  
for 0.05 – 6.0 GHz Higher Power Applications

MASW-000822-12770T  
Rev 1.0

**MAASW-000822-12770T Typical Performance Curves @ +25°C: Tx & Rx Isolation**  
20 mA for Loss, 11 V Back Bias for Isolation

MASW-000822-12770T, Tx & Rx Isolation, 25C

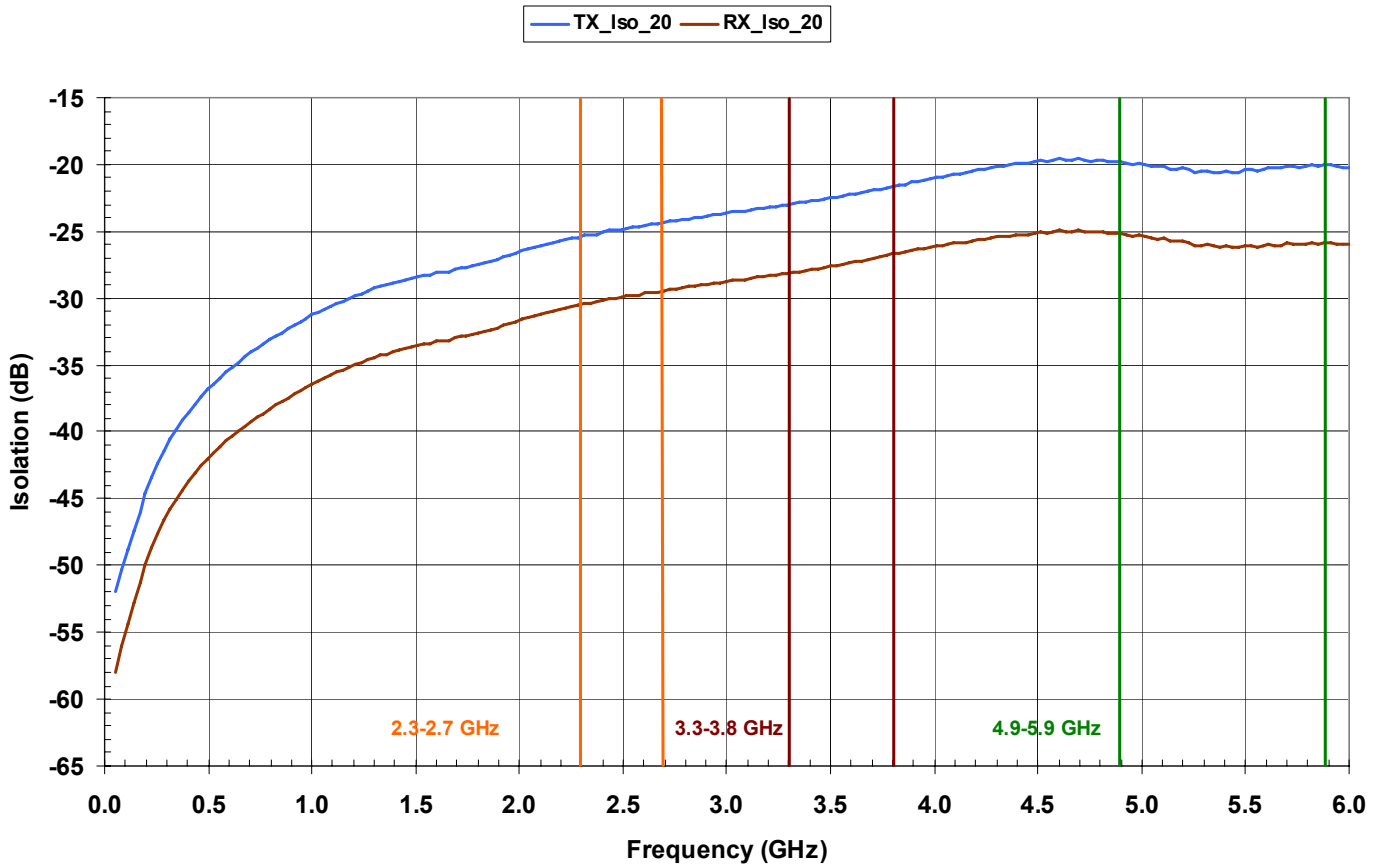

HMIC™ PIN Diode SP2T 8 Watt Switch  
for 0.05 – 6.0 GHz Higher Power Applications

MASW-000822-12770T  
Rev 1.0

**MASW-000822-12770T Typical Performance Curves @ +25°C : Tx Return Loss  
20 mA for Loss, 11 V Back Bias for Isolation**

MASW-000822-12770T, TX Return Loss ( S11 ), + 25C

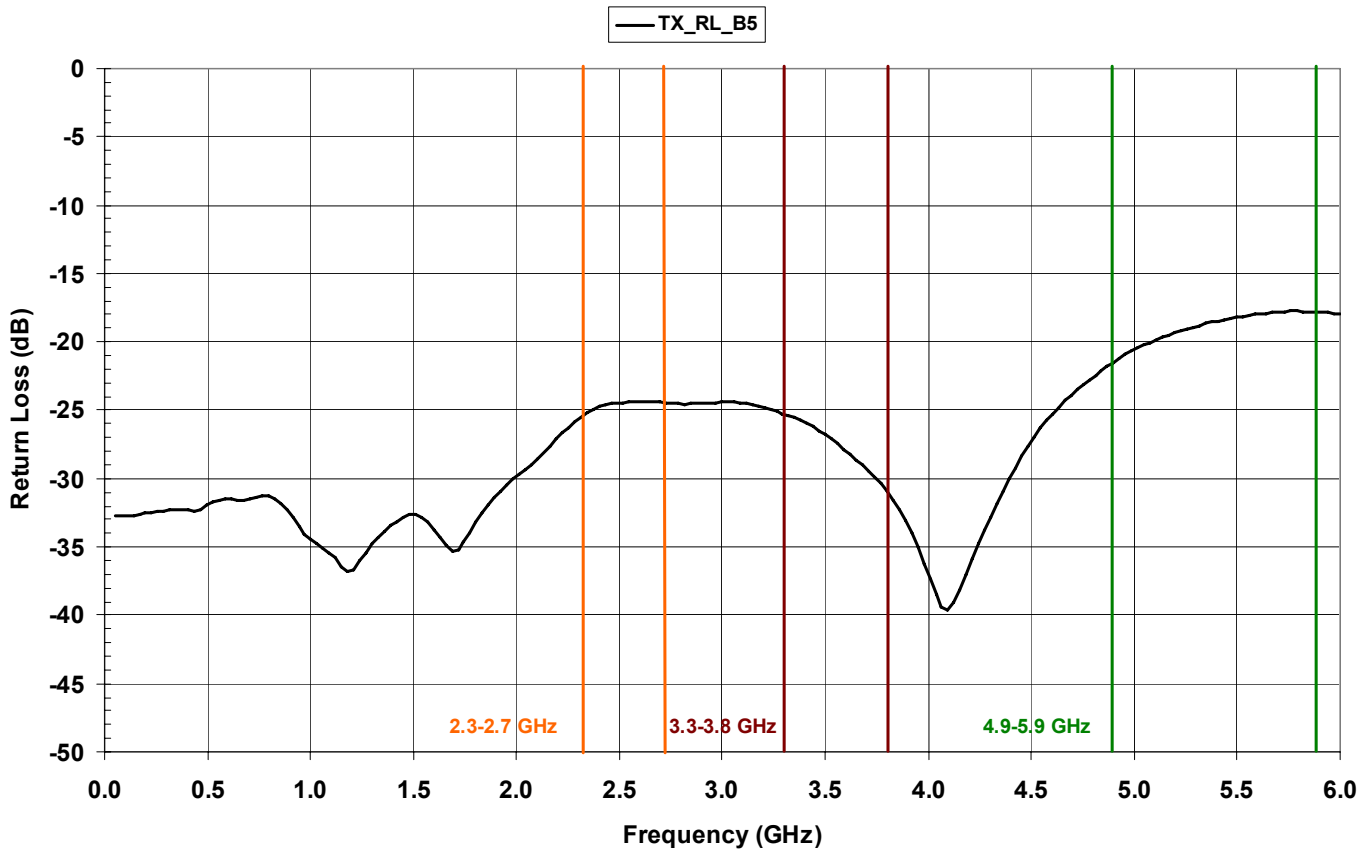

HMIC™ PIN Diode SP2T 8 Watt Switch  
for 0.05 – 6.0 GHz Higher Power Applications

MASW-000822-12770T  
Rev 1.0

**MASW-000822-12770T Typical Performance Curves @ +25°C : Rx Return Loss  
20 mA for Loss, 11 V Back Bias for Isolation**

MASW-000822-12770T, RX Return Loss ( S11 ), +25C

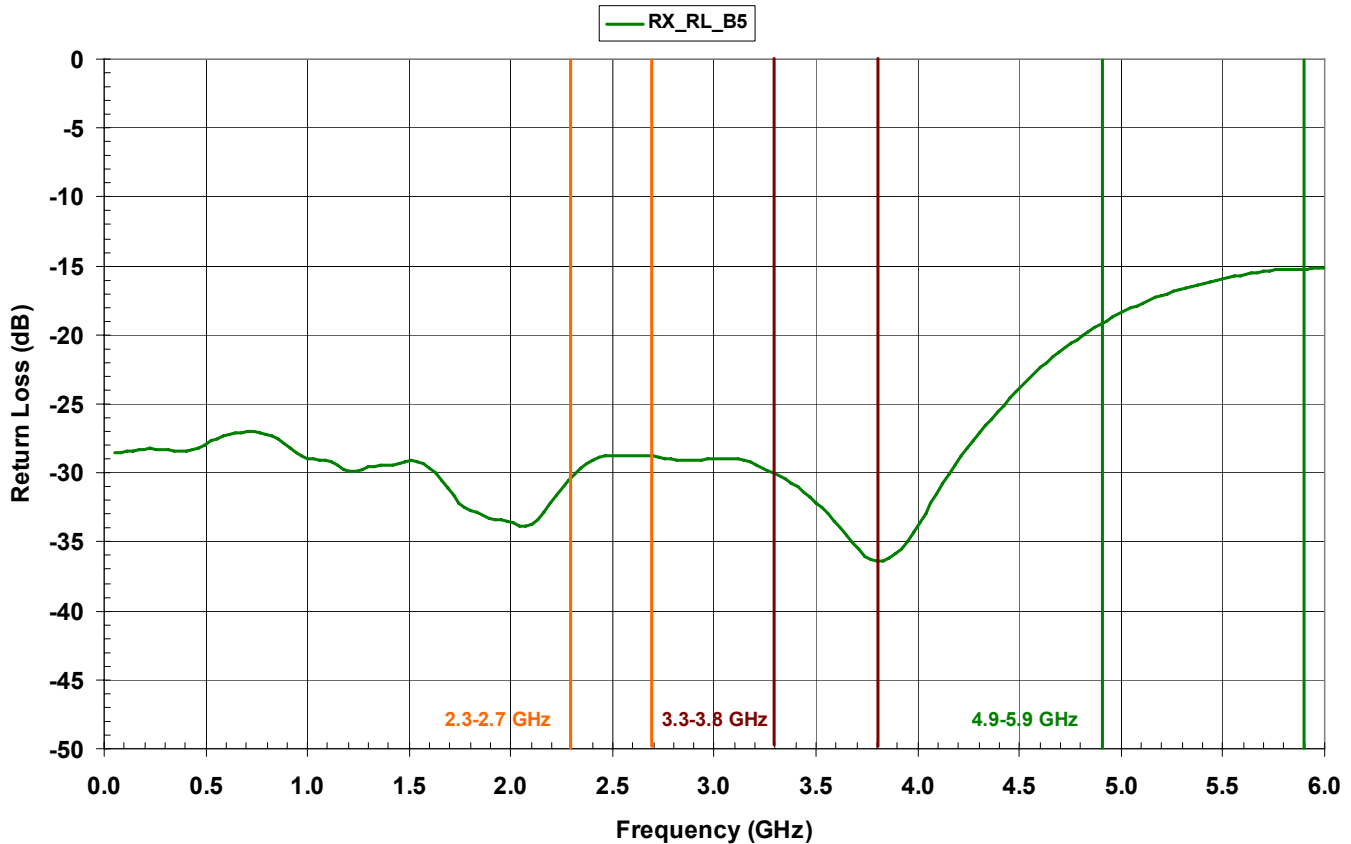

**HMIC™ PIN Diode SP2T 8 Watt Switch  
for 0.05 – 6.0 GHz Higher Power Applications**

**MASW-000822-12770T  
Rev 1.0**

**MASW-000822-12770T Outline – 3mm FQFP-N 16 Lead Saw Singulated**

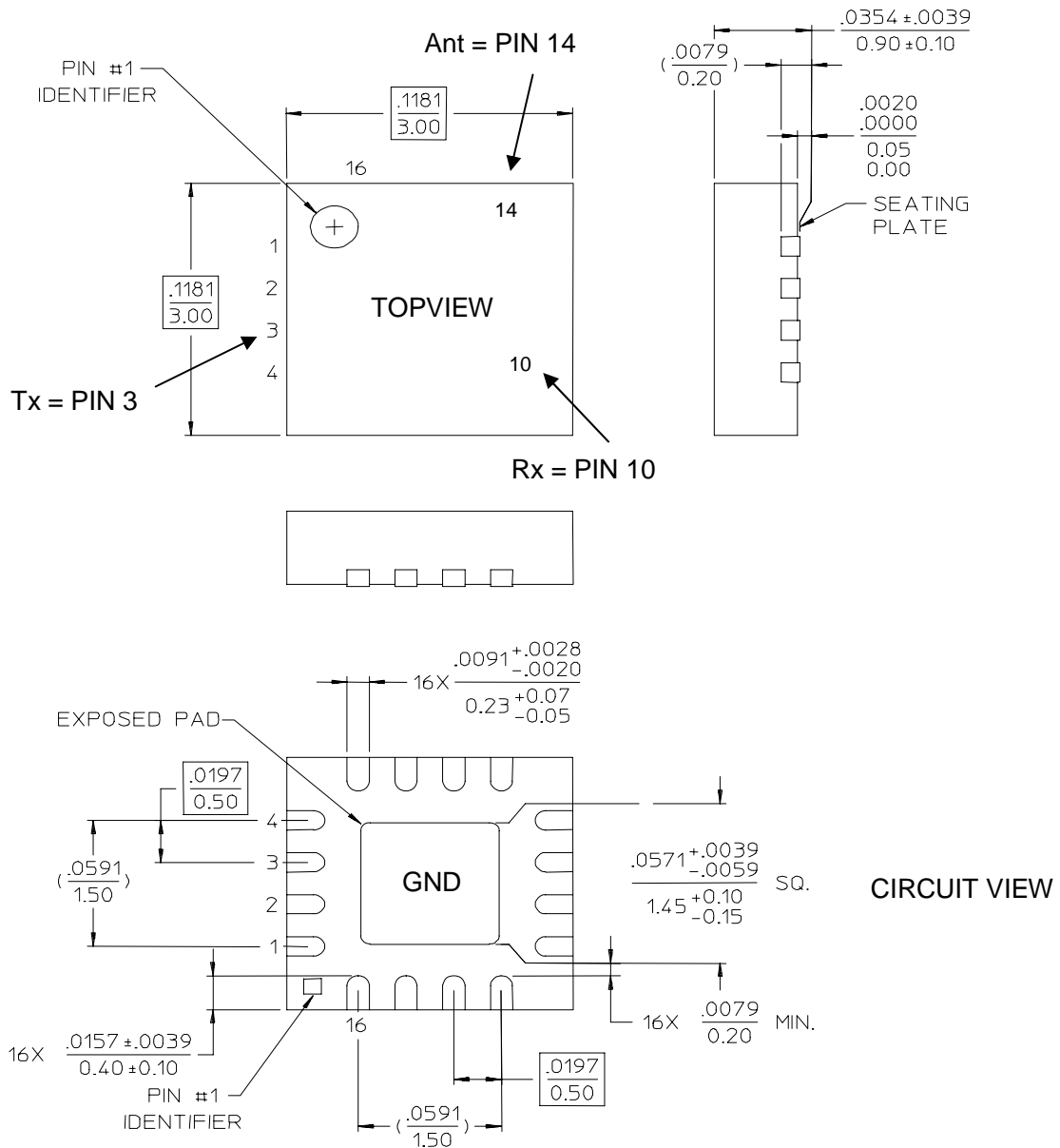

- NOTES: 1. REFERENCE JEDEC MO-220, VAR. VBED-1 FOR ADDITIONAL DIMENSIONAL AND TOLERANCE INFORMATION.  
2. REFERENCE S2083 APPLICATION NOTE FOR PCB FOOTPRINT INFORMATION.  
3. ALL DIMENSIONS SHOWN AS INCHES/MM.



**HMIC™ PIN Diode SP2T 8 Watt Switch  
for 0.05 – 6.0 GHz Higher Power Applications**

**MASW-000822-12770T  
Rev 1.0**

**Driver and SP2T Schematic with Positive Voltage**

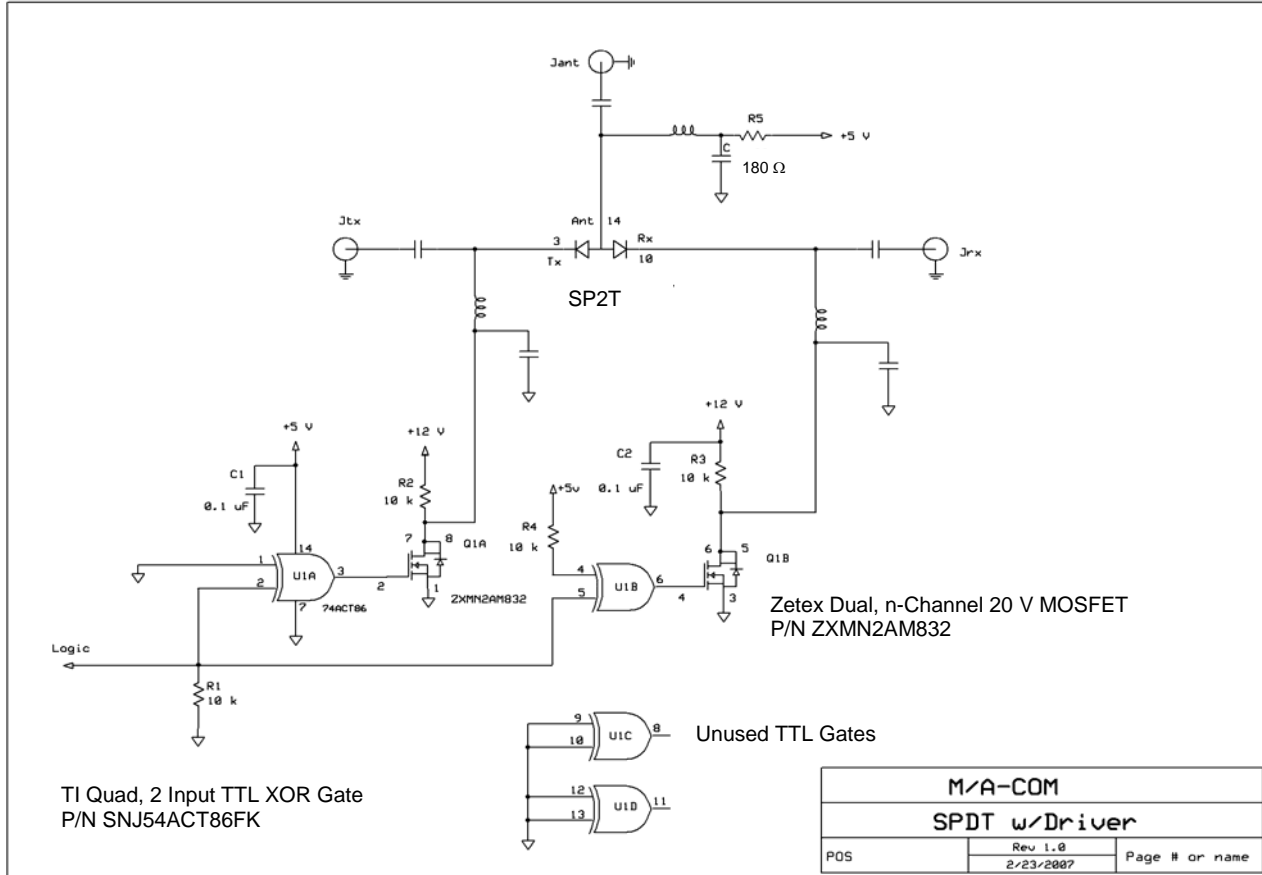

**Notes:**

1. Forward Bias Diode Voltage,  $\Delta V_f @ 22 \text{ mA} = +0.9 \text{ V}$ .
2. Reverse Bias Diode =  $| - (+12 \text{ V} - +0.9 \text{ V}) | = | - 11.1 | \text{ V}$ .
3. Nominal Zetex ZXMN2AM832 MOSFET Low Output Voltage,  $V_{ds} \sim +0 \text{ V} @ 22 \text{ mA}$ .
4. The ZXMN2AM832 may be operated with +5V with a small reduction in RF Isolation.
5. Un-used Texas Instruments SN54ACT86 XOR TTL Inputs are grounded.

**D.C. Bias to RF Truth Table**

RF State	TTL & D.C. Bias Conditions	Voltage at Common Anode
Low Loss Tx-Ant & Isolation Tx-Rx	TTL = 1 + 5V @ 22 mA ( Tx ), + 12V @ 0 mA ( Rx )	+ 0.9 V
Low Loss Ant-Rx & Isolation Rx-Tx	TTL = 0 + 5V @ 22 mA ( Rx ), + 12V @ 0 mA ( Tx )	+ 0.9 V

**HMIC™ PIN Diode SP2T 8 Watt Switch  
for 0.05 – 6.0 GHz Higher Power Applications**

**MASW-000822-12770T  
Rev 1.0**

**Driver and SP2T Schematic with Positive and Negative Voltage**

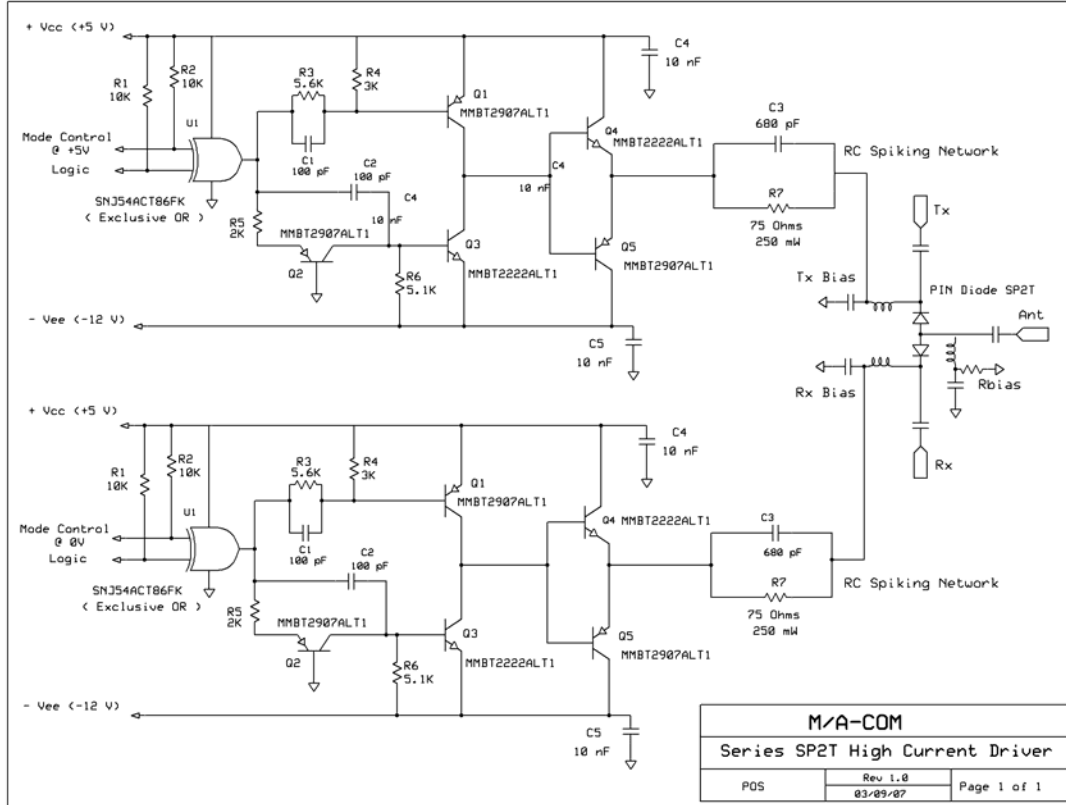

**D.C. Bias to RF Truth Table**

RF State	TTL & D.C. Bias Conditions	Voltage at Common Anode Rbias = 120Ω - I bias = - 50 mA
Low Loss Tx-Ant & Isolation Tx-Rx	TTL = 1 -12V @ -50mA ( Tx ), + 5V @ 0 mA ( Rx )	- 6.0 V
Low Loss Ant-Rx & Isolation Rx-Tx	TTL = 0 -12V @ -50mA ( Rx ), + 5V @ 0 mA ( Tx )	- 6.0 V

**Notes for TTL Compatible Driver Functionality using +Vcc and -Vee.**

- The Mode Control defines the Type of TTL Logic. Grounding the Mode Control produces Inverting Logic:  
TTL 0 ( Input ) = +V , + I ( Output ), and TTL 1 ( Input ) = -V , -I ( Output ).  
Consequently Connecting the Mode Control to +5V , produces Non- Inverting Logic:  
TTL 0 ( Input ) = -V , - I ( Output ), and TTL 1 ( Input ) = +V , +I ( Output ).
- Open circuit output voltage ~ ( +Vcc-0.8V ) or( -Vee + 0.8V ). Diode Forward Voltage , ΔVd @ 50 mA ~ 1.0 V.
- Rbias is used to build reverse D.C.voltage for the isolated , “ OFF “ , Series diode to Improve RF Linearity under High RF Signal.  
Available Negative Bias Current = ( -Vee + ΔVbe + ΔVce + ΔVd ) / ( 75Ω+Rbias ) = ( -Vee + 0.3 V + 0.7+ 1.0 V ) / ( 75Ω+Rbias ). As example, using -Vee = -12V for -50 mA bias current to forward Biased PIN Diode, Rbias = [ ( -12V + 2.0 V ) / - 0.05 A ] - 75Ω = 125 Ω.  
In this example, using Rbias = 120 Ω, Tx Bias Voltage ~ - [ ( 120 Ω\*0.05A ) + 1.0 V ] ~ -7.0 V.  
Using + Vcc = + 5V, the “ OFF “ Series Diode will have a Back Biased Voltage ~ | -6.0 V - ( 5 - 0.8 ) V | = | -10.2 V |.
- The SP2T Switch can be operated from -Vee = -5V with slightly degraded Tx linearity.