

HMIC™ PIN Diode SP2T 13 Watt Switch for TD-SCDMA Applications

Rev. V5

Features

- Exceptional Tx Loss = 0.35 dB Avg @ 2025 MHz, 20mA
- Exceptional Rx Loss = 0.50 dB Avg @ 2025 MHz, 20mA
- Higher Tx-Rx Isolation = 31dB Avg @ 2025 MHz, 20mA
- Higher RF C.W. Input Power =13 W C.W.(Tx-Ant Port)
- Higher RF Peak Power =+49.5 dBm, 5uS P.W.,1 % duty
- Higher IIP3=64 dBm (Tx-Ant Port)
- Lower EVM (OFDM): < 1.5 % @13W Pinc, (Tx-Ant Port)
- Surface Mount 3mm MLP Package, RoHS* Compliant

Description and Applications

The MA-COM MASW-000823-12770T is a SP2T, High Peak and Average Power, High Linearity, Common Anode, PIN diode LNA Protect Switch for TD-SCDMA(2010-2025 MHz) applications.

The device is provided in industry standard 3mm MLP plastic packaging. This device incorporates a PIN diode die fabricated with M/A-COM's patented Silicon-Glass HMIC™ process. This chip features two silicon pedestals embedded in a low loss, low dispersion glass. The diodes are formed on the top of each pedestal. The topside is fully encapsulated with silicon nitride and has an additional polymer passivation layer. These polymer protective coatings prevent damage and contamination during handling and assembly.

This compact SP2T PIN diode switch in 3mm MLP package, offers extraordinary performance with excellent isolation to loss ratio for both Tx and Rx states. The SP2T provides outstanding 13 W C.W. power handling coupled with 64 dBm IIP3 for maximum switch performance.

Absolute Maximum Ratings ¹

@ T_A = +25 °C (unless otherwise specified)

Parameter	Absolute Maximum
Forward Current	200 mA
Reverse Voltage (RF & D.C.)	-130 V
Operating Temperature	-40 °C to +85 °C
Storage Temperature	-55 °C to +150 °C
Junction Temperature	+175 °C
Tx Incident C.W. Power	13 W C.W.
Tx Peak Incident Power With 3.0:1 Maximum Ant VSWR	90 W, 5 uS P.W., 1% Duty
Mounting Temperature	+235 °C for 10 seconds

1. Exceeding these limits may cause permanent damage.

Functional Diagram (TOP VIEW)

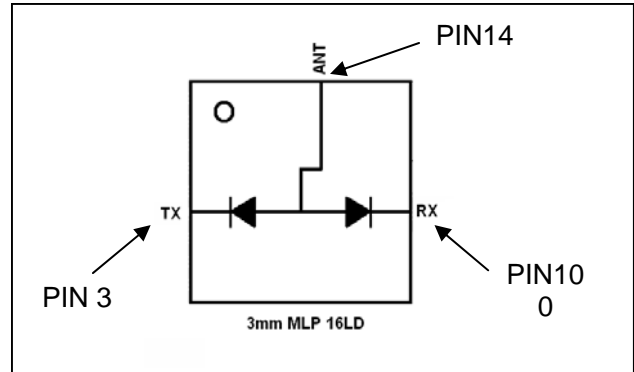

Circuit Side View

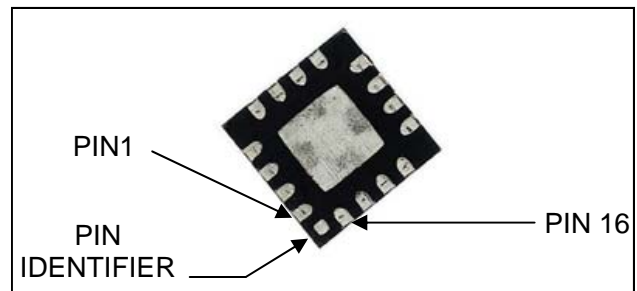

PIN Configuration:

(Center Metal Area is RF, D.C., and Thermal Ground)

PIN	Function	PIN	Function
1	N/C	9	N/C
2	N/C	10	Rx
3	Tx	11	N/C
4	N/C	12	N/C
5	N/C	13	N/C
6	N/C	14	Ant
7	N/C	15	N/C
8	N/C	16	N/C

Ordering Information

Part Number	Package
MASW-000823-12770T	Tape and Reel

ADVANCED: Data Sheets contain information regarding a product M/A-COM Technology Solutions is considering for development. Performance is based on target specifications, simulated results, and/or prototype measurements. Commitment to develop is not guaranteed.

PRELIMINARY: Data Sheets contain information regarding a product M/A-COM Technology Solutions has under development. Performance is based on engineering tests. Specifications are typical. Mechanical outline has been fixed. Engineering samples and/or test data may be available. Commitment to produce in volume is not guaranteed.

- **North America** Tel: 800.366.2266 / Fax: 978.366.2266
- **Europe** Tel: 44.1908.574.200 / Fax: 44.1908.574.300
- **Asia/Pacific** Tel: 81.44.844.8296 / Fax: 81.44.844.8298

Visit www.macomtech.com for additional data sheets and product information.

M/A-COM Technology Solutions Inc. and its affiliates reserve the right to make changes to the product(s) or information contained herein without notice.

HMIC™ PIN Diode SP2T 13 Watt Switch for TD-SCDMA Applications

Rev. V5

Electrical Specifications at +25°C, Characteristic Impedance, $Z_0 = 50 \Omega$

Parameter	Symbol	Conditions	Units	Min	Typ	Max
F = 2010- 2025 MHz						
Insertion Loss, Tx - Ant	Tx IL	Tx = +5.0 V@ +22mA, Rx =+28V @ 0mA, Pinc= 0 dBm, Tx-Ant	dB		0.35	0.50
Insertion Loss, Ant - Rx	Rx IL	Rx = +5.0 V@ +22mA, Tx =+28V @ 0mA, Pinc= 0 dBm, Ant-Rx	dB		0.50	0.70
Isolation, Tx - Rx	Rx ISO	Tx = +5.0 V@ +22mA, Rx =+28V @ 0mA, Pinc= 0 dBm, Tx-Rx	dB	28.5	31	
Isolation, Rx - Tx	Tx ISO	Rx = +5.0 V@ +22mA, Tx =+28V @ 0mA, Pinc= 0 dBm, Rx-Tx	dB	24.5	26	
Tx Input Return Loss	Tx RL	Tx = +5.0 V@ +22mA, Rx =+28V @ 0mA, Pinc= 0 dBm, Tx-Ant	dB		33	
Rx Input Return Loss	Rx RL	Rx = +5.0 V@ +22mA, Tx =+28V @ 0mA, Pinc= 0 dBm, Rx-Ant	dB		36	
Tx Input P0.1dB	Tx IP0.1dB	2.010 GHz, Tx = +5.0 V@ +22mA, Rx =+28V @ 0mA Tx To Antenna	dBm		40	
Tx Input P1dB	Tx IP1dB	2.010 GHz, Tx = +5.0 V@ +22mA, Rx =+28V @ 0mA Tx To Antenna	dBm		> 45	
Tx 2 nd Harmonic	Tx 2Fo	Fo=2.010 GHz, Tx = +5.0 V@ +22mA, Rx =+28V @ 0mA Pin = + 30 dBm, Tx To Antenna	dBc		63	
Tx 3 rd Harmonic	Tx 3Fo	Fo= 2.010 GHz, Tx = +5.0 V@ +22mA, Rx =+28V @ 0mA Pin = + 30 dBm, Tx To Antenna	dBc		80	
Tx Input Third Order Intercept Point	Tx IIP3	Tx = +5.0 V@ +22mA, Rx =+28V @ 0mA Pi= +10dBm, F1 = 2.010 GHz, F2 = 2.025 GHz, Tx To Antenna	dBm		64	
Tx C.W. Input Power	Tx cwPinc	Tx = +5.0 V@ +22mA, Rx =+28V @ 0mA F = 2.010 GHz, Tx To Antenna	dBm			41.1
Tx Peak Input Power	Tx pkPinc	Tx = +5.0 V@ +22mA, Rx =+28V @ 0mA F = 2.010 GHz, Tx To Antenna (5 μ S RF Pulse Width, 1% Duty , 3.0:1 Ant VSWR)	dBm			49.5
Rx C.W. Input Power	Rx cwPinc	Rx = +5.0 V@ +22mA, Tx =+28V @ 0mA F = 2.010 GHz, Antenna to Rx	dBm			33
Tx RF Switching Speed	τ_{RF}	(10% - 90% RF Voltage) Tx = +5.0 V@ +22mA, Rx =+28V @ 0mA F = 2.010 GHz, Tx To Antenna 1MHz Rep Rate in Modulating Mode	μ s		1	
Tx EVM (OFDM) QAM 64	EVM	Tx = +5.0 V@ +22mA, Rx =+28V @ 0mA Pinc = +41.1 dBm, Tx-Ant	%		1.5	

ESD Rating : These devices are rated at Class 1B Human Body

2

ADVANCED: Data Sheets contain information regarding a product M/A-COM Technology Solutions is considering for development. Performance is based on target specifications, simulated results, and/or prototype measurements. Commitment to develop is not guaranteed.

PRELIMINARY: Data Sheets contain information regarding a product M/A-COM Technology Solutions has under development. Performance is based on engineering tests. Specifications are typical. Mechanical outline has been fixed. Engineering samples and/or test data may be available. Commitment to produce in volume is not guaranteed.

• **North America** Tel: 800.366.2266 / Fax: 978.366.2266

• **Europe** Tel: 44.1908.574.200 / Fax: 44.1908.574.300

• **Asia/Pacific** Tel: 81.44.844.8296 / Fax: 81.44.844.8298

Visit www.macomtech.com for additional data sheets and product information.

M/A-COM Technology Solutions Inc. and its affiliates reserve the right to make changes to the product(s) or information contained herein without notice.

Typical Performance Curves @ +25°C

Tx Insertion Loss (Bias Conditions: 10 mA and 20 mA for Low Loss, 27 V Back Bias for Isolation Port)

MASW-000823-12770T Tx-Ant Insertion Loss vs Frequency and Current

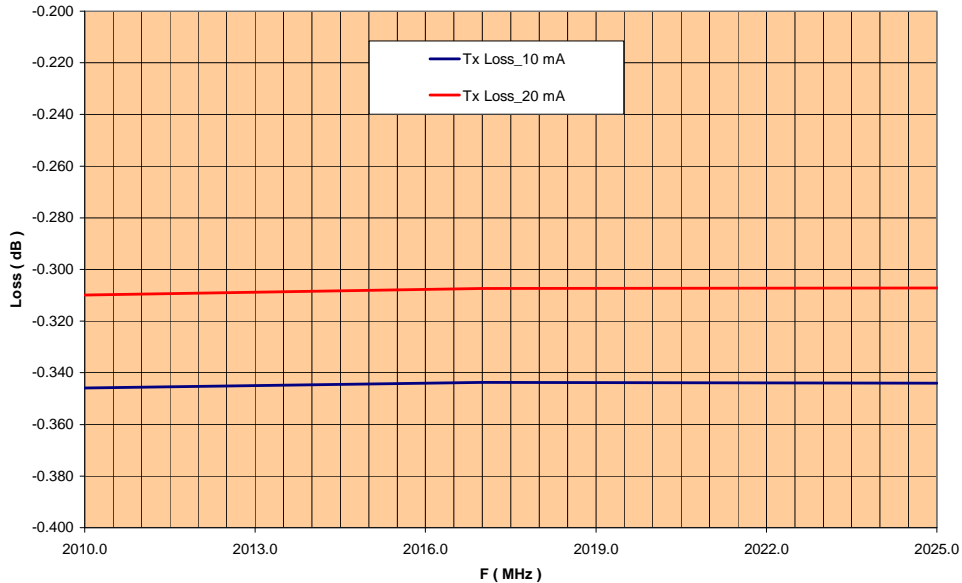

Rx Insertion Loss (Bias Conditions: 10 mA and 20 mA for Low Loss, 27 V Back Bias for Isolation Port)

MASW-000823-12770T Ant-Rx Insertion Loss vs Frequency and Current

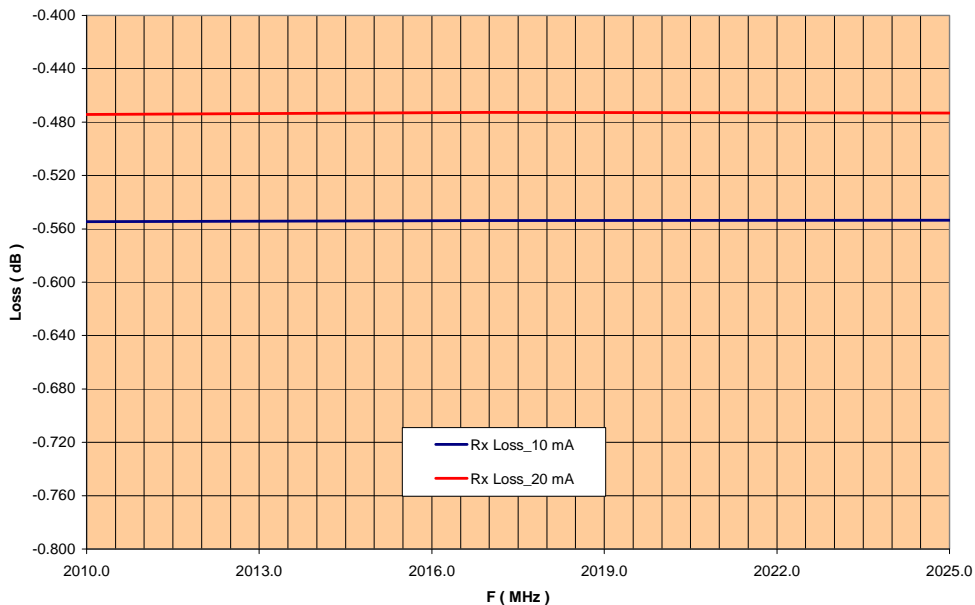

Typical Performance Curves @ +25°C

Tx & Rx Return Loss (Bias Conditions: 20 mA for Loss, 27 V Back Bias for Isolation Port)

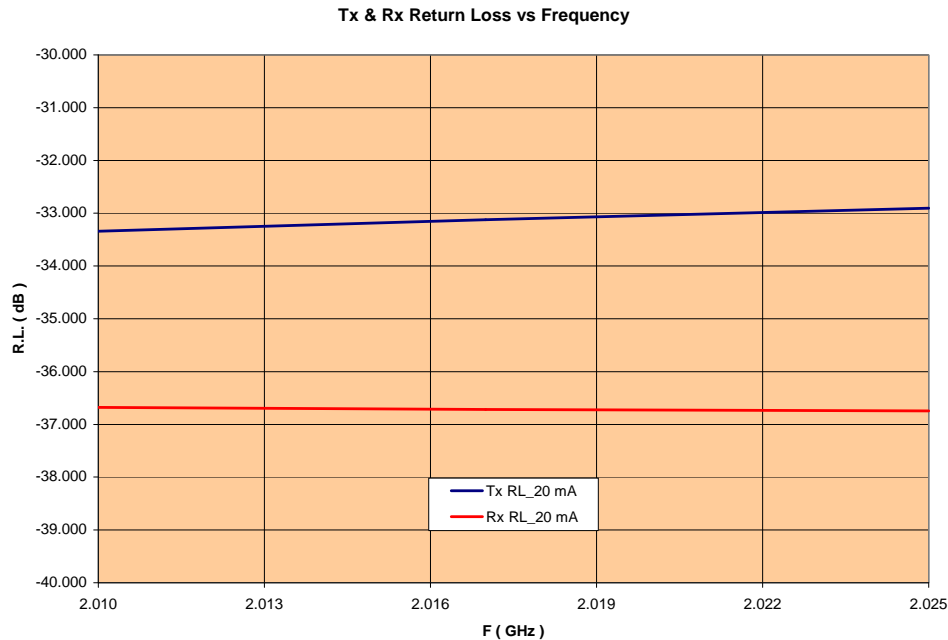

Tx-Rx & Rx-Tx Isolation (Bias Conditions: 20 mA for Loss, 27 V Back Bias for Isolation Port)

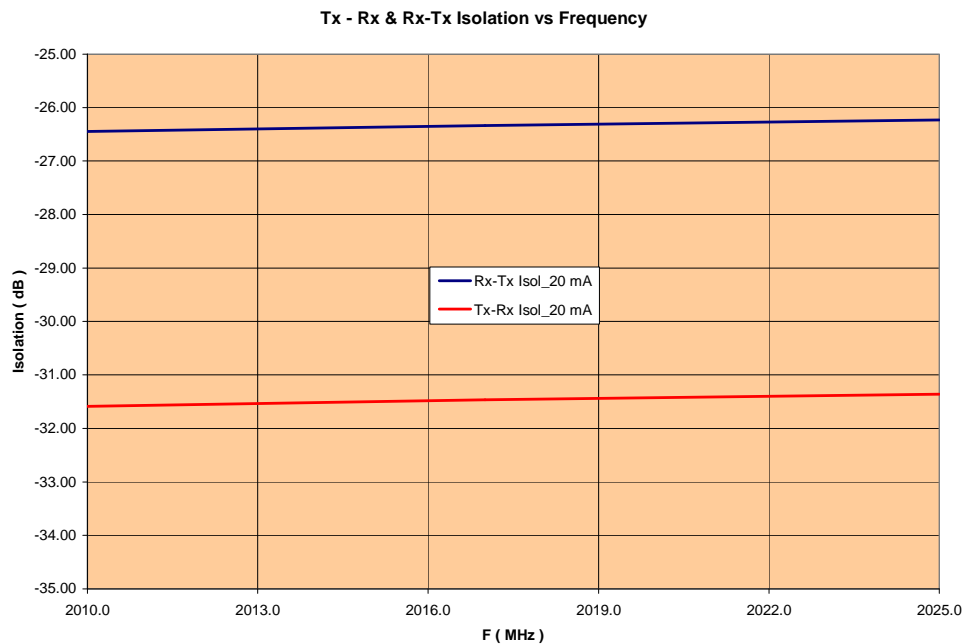

HMIC™ PIN Diode SP2T 13 Watt Switch for TD-SCDMA Applications

Rev. V5

Notes:

1. Data is taken on M/A-COM evaluation board 1000029181-0000001 @ 25C by removing peripheral board losses (connectors, transmission line, and bias elements).
2. MA-COM PIN Diode Driver, MADR-008888-0001TR, Operating with +5V and + 28V, is recommended for usage with the MASW-000823-12770T SP2T Switch.
3. Typical PIN Diode Forward Voltage = + 0.9 V @ + 22 mA for Insertion Loss.
Typical PIN Diode Reverse Voltage = 28 V – 1.0 V = 27 V for Isolation (See Bias Schematic).
4. Switch is Asymmetrical, + 41.1 dBm RF C.W. Input Power Applies to Tx Port Only.
5. Center Ground Area of MLP 3mm Package must be Attached to Thermal Ground for Optimum RF Power Performance.

Assembly Note:

A typical profile for a Sn 60/ Pb 40 Soldering process is provided in Application Note, “ M538, Surface Mounting Instructions ” on the MA-COM website, www.macom.com

TTL Driver and SP2T Schematic with +5V, + 28V D.C. Power ^{2,3,4,5}

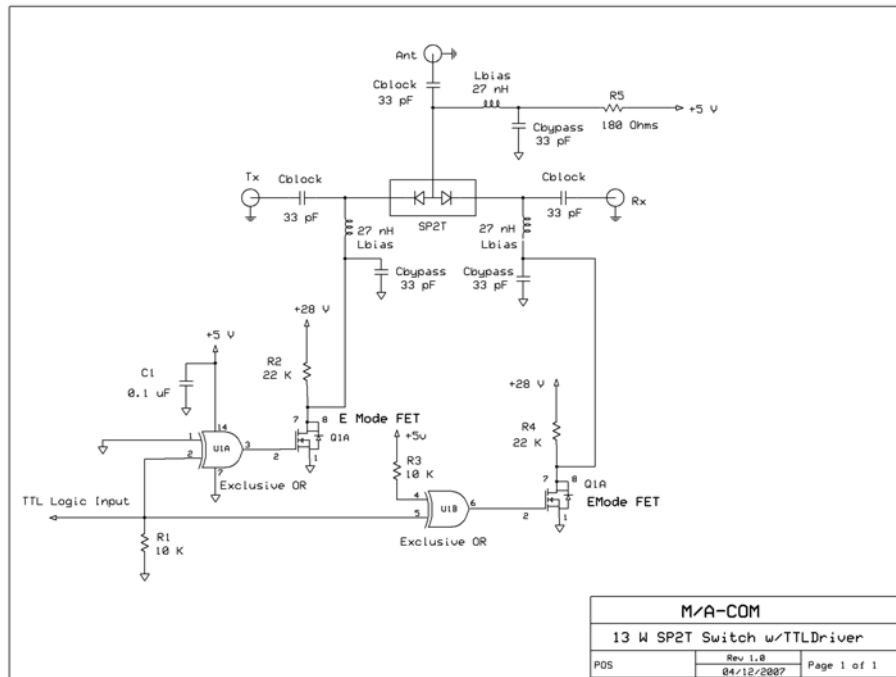

2. Forward Bias Diode Voltage, $\Delta V_f @ 22 \text{ mA} = + 0.9 \text{ V}$.
3. Reverse Bias Diode = $| - (+28 \text{ V} - +1.0 \text{ V}) | = | - 27 \text{ V} | \text{ V}$.
4. Nominal FET Low Output Voltage, $V_{ds} \sim + 0.1 \text{ V} @ 22 \text{ mA}$.
5. MA-COM PIN Diode Driver, MADR-008888-0001TR, is recommended for usage with the MASW-000823-12770T SP2T Switch.

D.C. Bias to RF Truth Table

RF State	TTL Logic & D.C. Supply Conditions	Voltage at Common Anode
Low Loss Tx-Ant & Isolation Tx-Rx	TTL = 1 + 5V @ 22 mA (Tx), + 28V @ 0 mA (Rx)	+ 1.0 V
Low Loss Ant-Rx & Isolation Rx-Tx	TTL = 0 + 5V @ 22 mA (Rx), + 28V @ 0 mA (Tx)	+ 1.0 V

ADVANCED: Data Sheets contain information regarding a product M/A-COM Technology Solutions is considering for development. Performance is based on target specifications, simulated results, and/or prototype measurements. Commitment to develop is not guaranteed.
PRELIMINARY: Data Sheets contain information regarding a product M/A-COM Technology Solutions has under development. Performance is based on engineering tests. Specifications are typical. Mechanical outline has been fixed. Engineering samples and/or test data may be available. Commitment to produce in volume is not guaranteed.

• **North America** Tel: 800.366.2266 / Fax: 978.366.2266
• **Europe** Tel: 44.1908.574.200 / Fax: 44.1908.574.300
• **Asia/Pacific** Tel: 81.44.844.8296 / Fax: 81.44.844.8298
Visit www.macomtech.com for additional data sheets and product information.

M/A-COM Technology Solutions Inc. and its affiliates reserve the right to make changes to the product(s) or information contained herein without notice.

MASW-000823-12770T Outline – 3mm FQFP-N 16 Lead Saw Singulated

