

MASW-004240-13170W

HMIC™ SP4T Surface Mount Silicon PIN Diode Switch with Integrated Bias Network

V1

Features

- ◆ Operating Freq. 10 ± 2GHz or 24 ± 2GHz
- ◆ Surface Mount Device
- ◆ Integrated Bias Network
- ◆ No Wire Bonds Required
- ◆ Low Current Consumption
+12 mA for On State/0V for Off Condition
- ◆ Rugged, Glass Encapsulated Construction
- ◆ Fully Monolithic
- ◆ Polymer Scratch Protection
- ◆ RoHS Compliant

Description

The MASW-004240-13170W is a surface mount SP4T switch chip with integrated bias network. It utilizes M/A-COM technology Solutions HMIC™ (Heterolithic Microwave Integrated Circuit) process, US Patent 5,268,310, which allows the incorporation of silicon pedestals that form series and shunt diodes or vias by imbedding them in low loss, low dispersion glass. By using small spacing between elements, this combination of silicon and glass gives HMIC devices low loss and high isolation performance with exceptional repeatability through low millimeter frequencies. Patterned gold backside metal allows for manual or re-flow soldering without the need for wire bond connections to the RF and bias ports. The chip may be soldered using 80Au/20Sn, RoHS compliant solders or electrically conductive silver epoxy. The RF bond pads are labeled J1-J5 and are 375x375µM (15x15mils) square. The DC bias bond pads are labeled B2-B5 and are also 375x375µM (15x15mils) square.

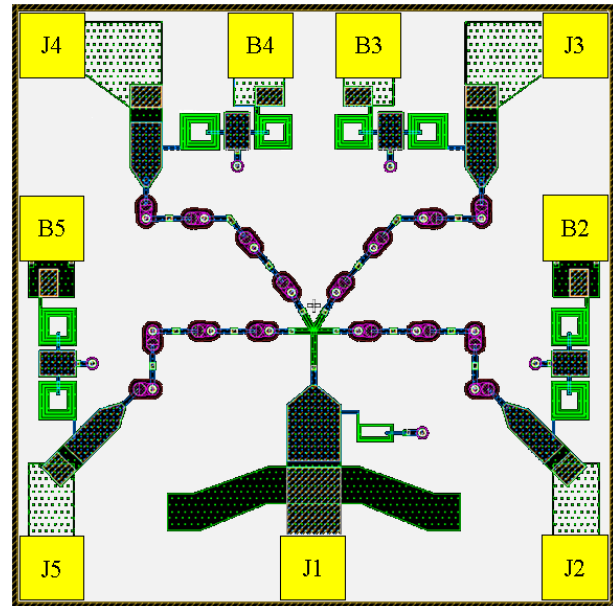

Yellow areas denote backside soldering points for bias and RF connections.

Parameter	Absolute Maximum
Operating Temperature	-65°C to +125°C
Storage Temperature	-65°C to +150°C
Junction Temperature	+175°C
Applied Forward Current	+40mA
RF Incident Power	+30dBm C.W.
Mounting Temperature	+280°C for 10 Seconds

Applications

The MASW-004240-13170W has been designed for 24GHz automotive radar sensor applications and is also ideally suited for use at 10GHz. The switch is turned on by applying a forward current of +12mA at 4V to the appropriate bias port and is turned off at 0V. The RF bias network has been incorporated into the design for ease of use and space considerations.

1

ADVANCED: Data Sheets contain information regarding a product M/A-COM Technology Solutions is considering for development. Performance is based on target specifications, simulated results, and/or prototype measurements. Commitment to develop is not guaranteed.
PRELIMINARY: Data Sheets contain information regarding a product M/A-COM Technology Solutions has under development. Performance is based on engineering tests. Specifications are typical. Mechanical outline has been fixed. Engineering samples and/or test data may be available. Commitment to produce in volume is not guaranteed.

• **North America** Tel: 800.366.2266 • **Europe** Tel: +353.21.244.6400
 • **India** Tel: +91.80.43537383 • **China** Tel: +86.21.2407.1588
 Visit www.macomtech.com for additional data sheets and product information.

M/A-COM Technology Solutions Inc. and its affiliates reserve the right to make changes to the product(s) or information contained herein without notice.

MASW-004240-13170W

HMIC™ SP4T Surface Mount Silicon PIN Diode Switch with Integrated Bias Network

V1

MASW-004240-13170W (SP4T) Electrical Specifications @ T_{AMB} = +25°C

Parameter	Frequency	Port 1	Port 2	Stimulus	Minimum	Typical	Maximum
Insertion Loss	10GHz & 24GHz	J1	J2	12mA @ B2		2.5	3.5dB
		J1	J3	12mA @ B3		2.5	3.5dB
		J1	J4	12mA @ B4		2.5	3.5dB
		J1	J5	12mA @ B5		2.5	3.5dB
Isolation	10GHz & 24GHz	J1	J2	12mA @ B2	40dB	50	
		J1	J3	12mA @ B3	40dB	50	
		J1	J4	12mA @ B4	40dB	50	
		J1	J5	12mA @ B5	40dB	50	
Input Return Loss	10GHz & 24GHz	J1	J2	12mA @ B2		14	
		J1	J3	12mA @ B3		14	
		J1	J4	12mA @ B4		14	
		J1	J5	12mA @ B5		14	

MASW-004240-13170W

HMIC™ SP4T Surface Mount Silicon PIN Diode Switch with Integrated Bias Network

V1

TYPICAL INSERTION LOSS

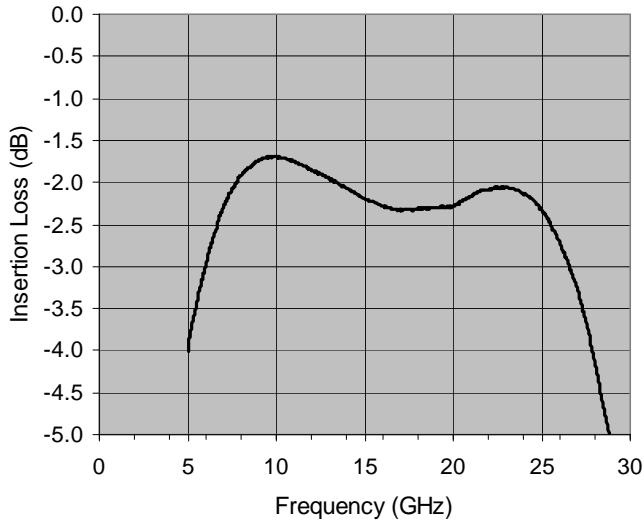

TYPICAL ISOLATION

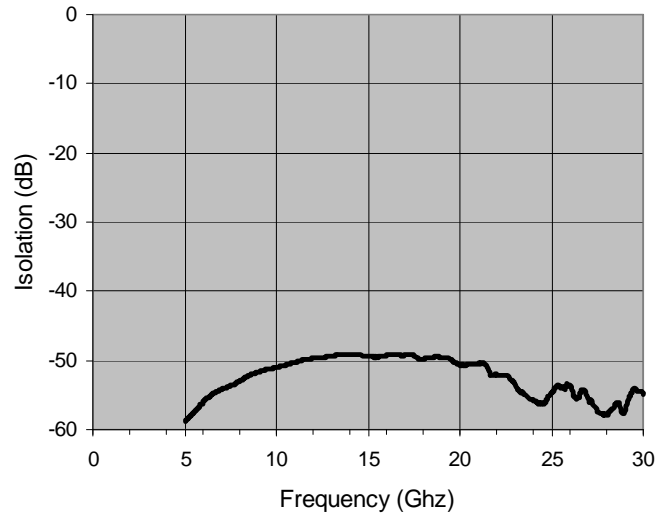

TYPICAL INPUT RETURN LOSS

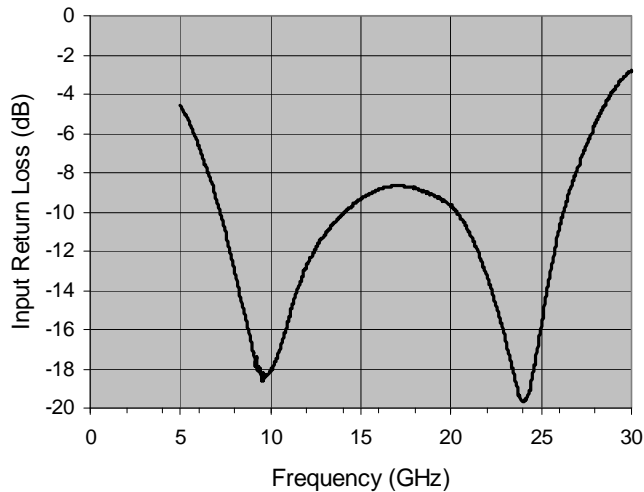

TYPICAL OUTPUT RETURN LOSS

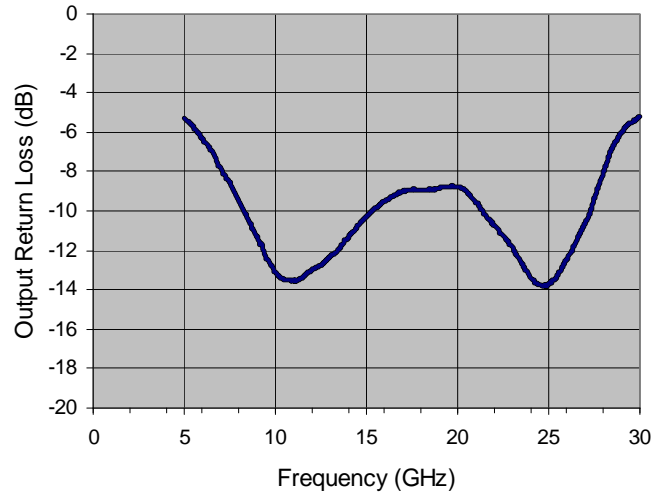

ADVANCED: Data Sheets contain information regarding a product M/A-COM Technology Solutions is considering for development. Performance is based on target specifications, simulated results, and/or prototype measurements. Commitment to develop is not guaranteed.
PRELIMINARY: Data Sheets contain information regarding a product M/A-COM Technology Solutions has under development. Performance is based on engineering tests. Specifications are typical. Mechanical outline has been fixed. Engineering samples and/or test data may be available. Commitment to produce in volume is not guaranteed.

• **North America** Tel: 800.366.2266 • **Europe** Tel: +353.21.244.6400
 • **India** Tel: +91.80.43537383 • **China** Tel: +86.21.2407.1588
 Visit www.macomtech.com for additional data sheets and product information.

M/A-COM Technology Solutions Inc. and its affiliates reserve the right to make changes to the product(s) or information contained herein without notice.

MASW-004240-13170W

HMIC™ SP4T Surface Mount Silicon PIN Diode Switch with Integrated Bias Network

V1

MASW-004240-13170W Schematic

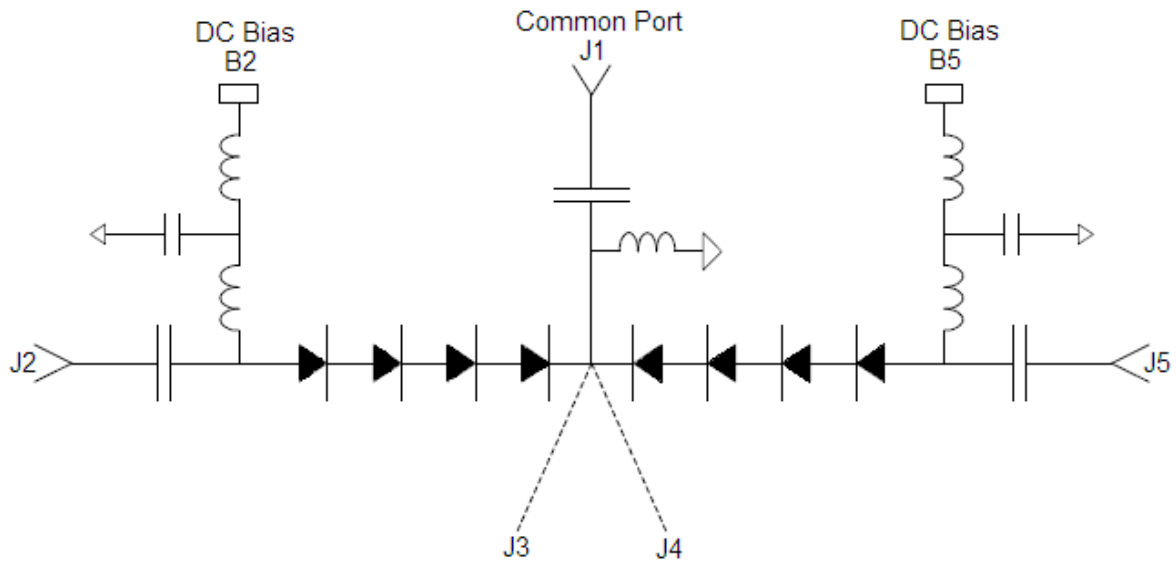

Operation of the MASW-004240-13170W

Operation of the MASW-00420-13170W PIN diode switch is achieved by simultaneously applying a current of +12mA DC to the bias port of the on arm and 0V to the remaining isolated off arms.

Driver Connections

Control Level (DC Current) at Port				Condition of RF Output			
B2	B3	B4	B5	J1-J2	J1-J3	J1-J4	J1-J5
-12mA	0V	0V	0V	Low Loss	Isolation	Isolation	Isolation
0V	-12mA	0V	0V	Isolation	Low Loss	Isolation	Isolation
0V	0V	-12mA	0V	Isolation	Isolation	Low Loss	Isolation
0V	0V	0V	-12mA	Isolation	Isolation	Isolation	Low Loss

MASW-004240-13170W

HMIC™ SP4T Surface Mount Silicon PIN Diode Switch with Integrated Bias Network

V1

Chip Dimensions and Pad Locations^{1,2,3}

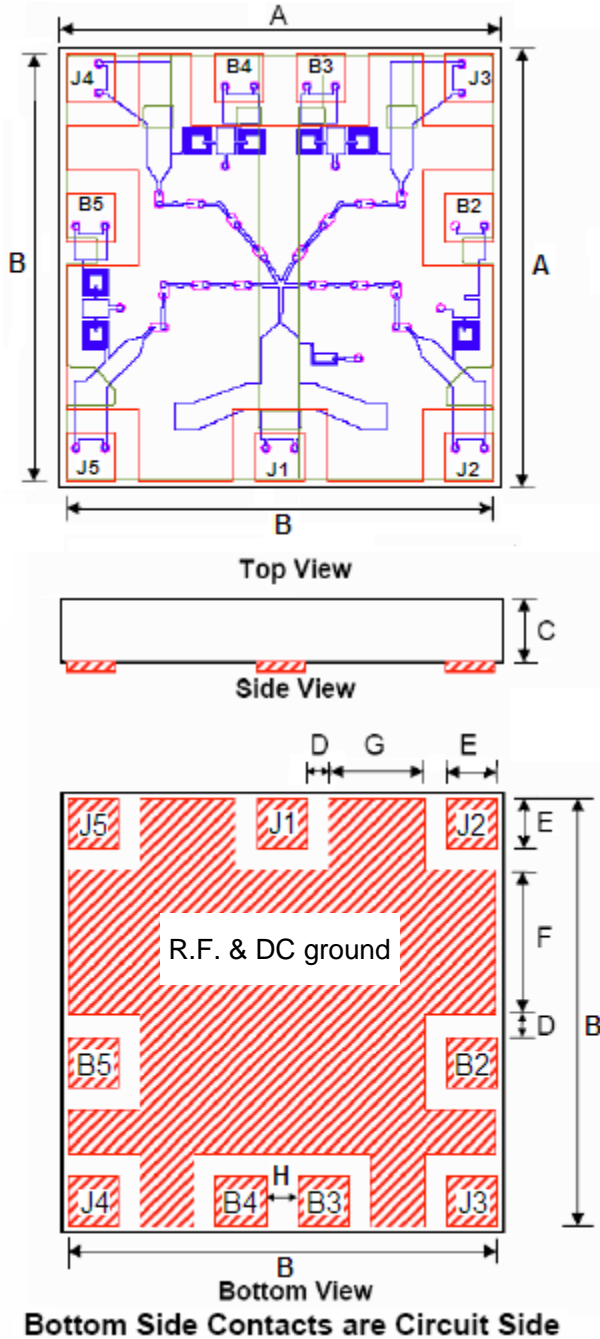

Chip Dimensions				
Dim	Mils		Millimeters	
	Min.	Max	Min.	Max
A	132.0	134.0	3.350	3.400
B	128.5	129.0	3.270	3.280
C	4.0	6.0	0.102	0.152
D	67.0	71.0	0.170	0.180
E	14.5	15.0	0.370	0.380
F	43.3	43.7	1.100	1.110
G	28.3	28.7	0.720	0.730
H	9.5	10.0	0.245	0.255

Bond Pad Centers				
Dim	Mils		Millimeters	
	X	Y	X	Y
J1	0	-57	0	-1.450
J2	-57	-57	1.450	-1.450
J3	57	57	1.450	1.450
J4	-57	57	-1.450	1.450
J5	-57	-57	-1.450	-0.145
B2	-57	15	1.450	0.380
B3	12	57	0.313	1.450
B4	-12	57	-0.313	1.450
B5	-57	15	-1.450	0.380

Notes:

1. Backside metallization thickness is 0.01μm.
2. Hatched areas indicate backside ohmic gold contacts
3. Bond pad centers are referenced from chip center.

Die Attachment and Handling Guidelines

Handling

All semiconductor chips should be handled with care to avoid damage or contamination from perspiration and skin oils. The use of plastic tipped tweezers or vacuum pickups is strongly recommended for individual components. Bulk handling should insure that abrasion and mechanical shock are minimized.

Bonding

Attachment to a circuit board is made simple through the use of surface mount technology. Mounting pads are conveniently located on the bottom surface of these devices and are removed from the active junction locations. These devices are well suited for solder or conductive epoxy attachment onto hard or soft substrates. The use of 60Pb/40Sn, 80Au/20Sn or any RoHS lead-free solder is recommended to achieve the lowest series resistance and optimum heat sink. .

When soldering these devices a hot gas or oven re-flow process is preferred. We recommend utilizing a vacuum tip and applying a downward force of 40 - 60 grams to the top surface of the device. When soldering, position the die so that its mounting pads are aligned with the circuit board mounting pads and reflow the solder by heating the circuit trace near the mounting pads while applying 40 to 60 grams of force perpendicular to the top surface of the die. All mounting pads should be heated simultaneously so that the solder under the pads flows at the same time. Avoid soldering the pads one at a time as doing so would produce an un-equal heat flow and potentially create thermal stress to the chip.

Solder reflow should not be performed by causing the heat to flow through the top surface of the die. Die should be uniformly heated in a re-flow oven. A typical heating profile and handling instructions are provided in Application Notes, [M538 Surface Mounting Instructions](#) and [M541 Bonding and Handling Procedures](#) on the MA-COM website at www.macomtech.com

Conductive silver epoxy may also be used for die attachment, in lower Incident power applications where the average power is <1W. Apply a thin controlled amount approximately 1- 2 mils thick to minimize ohmic and thermal stresses. Take care not to bridge the gap between the chip pads with epoxy. A thin epoxy fillet should be visible around the perimeter of the pads after placement to ensure full coverage. Cure per epoxy per manufacturer's recommended schedule. Typically 150°C for 1 hour.

Ordering Information

Part Number	Package
MASW-004240-13170W	Waffle Pack