

Features

- Broadband Performance
- Low Insertion Loss: 1.6 dB
- High Isolation: 30 dB
- Fast Switching Speed: 12 ns
- Reflective Configuration
- Ultra Low DC Power Consumption
- Lead-Free 3 mm 14-Lead PQFN Package
- RoHS* Compliant

Description

The MASW-011105 is a versatile, broadband, high isolation SPDT switch offered in a lead-free 3 mm 14-lead PQFN surface mount plastic package. The combination of broadband performance along with fast switching and excellent settling time make this device ideal for many applications, including test & measurement, EW and broadband communication systems.

The MASW-011105 is fabricated using MACOM's robust process with full surface passivation for a high performance and high reliability.

Ordering Information^{1,2}

Part Number	Package
MASW-011105-TR0500	500 piece reel
MASW-011105-TR1000	1000 piece reel
MASW-011105-001SMB	Sample Board

1. Reference Application Note M513 for reel size information.
2. All sample boards include 2 loose parts.

Functional Schematic

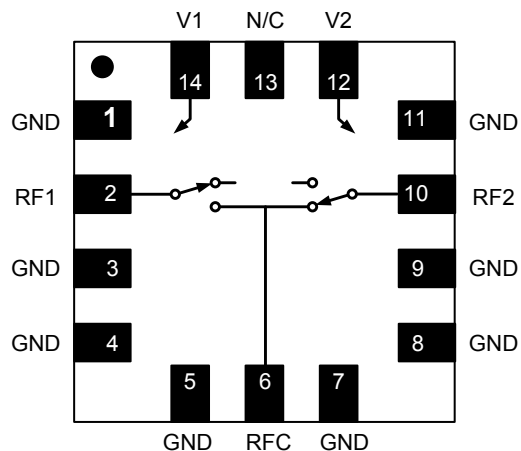

Pin Configuration³

Pin #	Pin Name	Function
1, 3-5, 7-9, 11	GND	Ground
2	RF1	RF Port 1
6	RFC	RF Common
10	RF2	RF Port 2
12	V2	Control Voltage
13	N/C	No Connection
14	V1	Control Voltage
15	Paddle ⁴	Ground

3. MACOM recommends connecting unused package pins to ground.
4. The exposed pad centered on the package bottom must be connected to RF, DC and thermal ground.

* Restrictions on Hazardous Substances, European Union Directive 2011/65/EU.

GaAs SPDT Switch 17.7 - 31.0 GHz

Rev. V1

Electrical Specifications: Freq. = 17.7 - 31.0 GHz, $T_A = +25^\circ\text{C}$, $V_{1,2} = 0/+5\text{ V}$, $Z_0 = 50\ \Omega$

Parameter	Test Conditions	Units	Min.	Typ.	Max.
Insertion Loss	—	dB	—	1.6	2.0
Isolation	—	dB	25	30	—
Port Amplitude Imbalance	—	dB	—	0.1	—
Port Phase Imbalance	—	°	—	5	—
Return Loss	RFC RF1, RF2	dB	—	15 15	—
Input P0.1dB	@ 24 GHz	dBm	—	24	—
Input IP3	Two Tone, +7 dBm/Tone, 5 MHz Spacing, 24 GHz	dBm	—	43	—
T_{RISE} , T_{FALL}	10% to 90% RF and 90% to 10% RF	ns	—	6	—
T_{ON} , T_{OFF}	50% control to 90% RF and 50% control to 10% RF	ns	—	12	—
Settling Time	50% Vctl to 0.1 dB of final value	ns	—	60	—
Control Current (Complementary Logic)	V Low (0 V), V High (5 V)	μA	—	1	2

Absolute Maximum Ratings^{5,6}

Parameter	Absolute Maximum
Control Voltage	8.5 V
Input Power	25 dBm
Operating Temperature	-40°C to +85°C
Storage Temperature	-65°C to +150°C

- Exceeding any one or combination of these limits may cause permanent damage to this device.
- MACOM does not recommend sustained operation near these survivability limits.

Truth Table⁷

Control Input		Condition of Switch	
V1	V2	RF1	RF2
1	0	On	Off
0	1	Off	On

7. Logic "0" = 0 to 0.2 V, Logic "1" = 5 to 5.2 V.

Handling Procedures

Please observe the following precautions to avoid damage:

Static Sensitivity

These electronic devices are sensitive to electrostatic discharge (ESD) and can be damaged by static electricity. Proper ESD control techniques should be used when handling these devices.

PCB Layout Recommendation

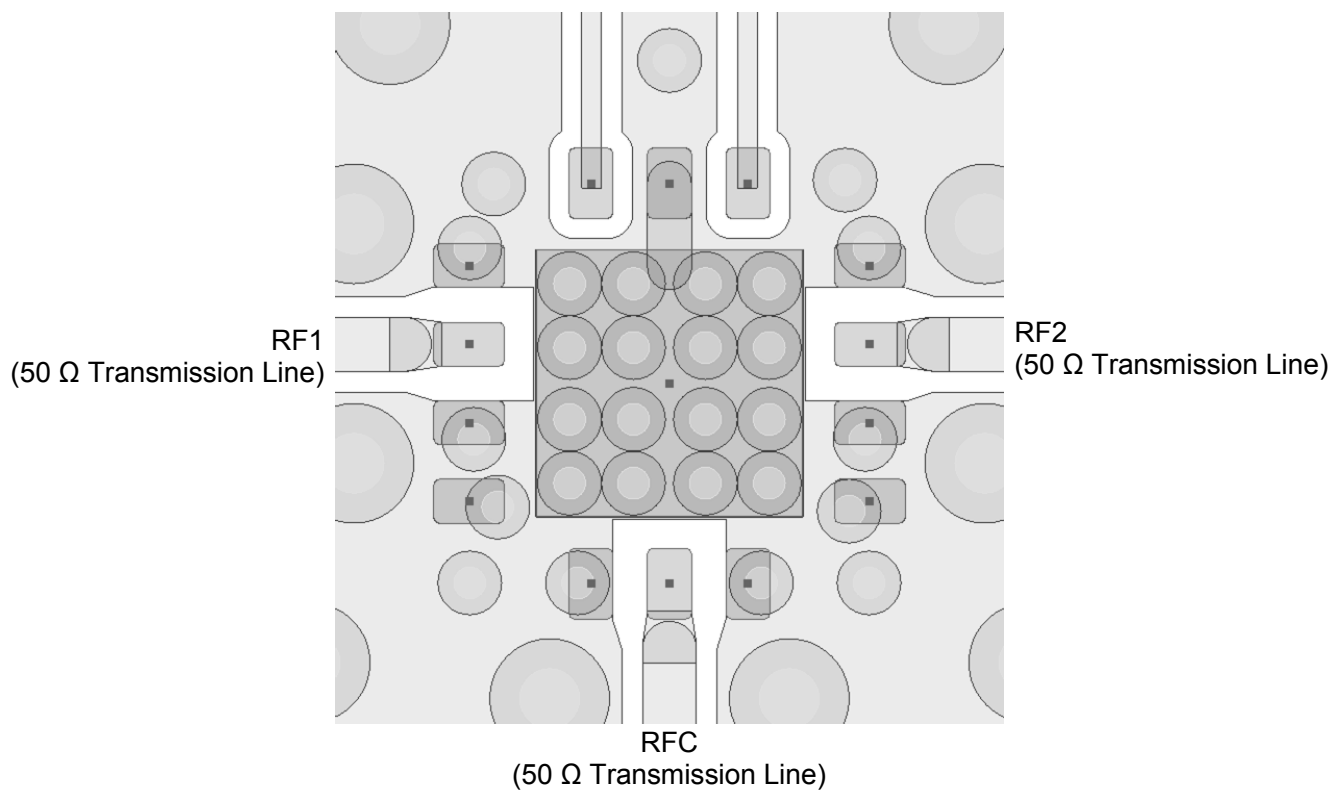

Ground of transmission lines should connect to package paddle in shortest possible way.

Typical Performance Curves

Insertion Loss

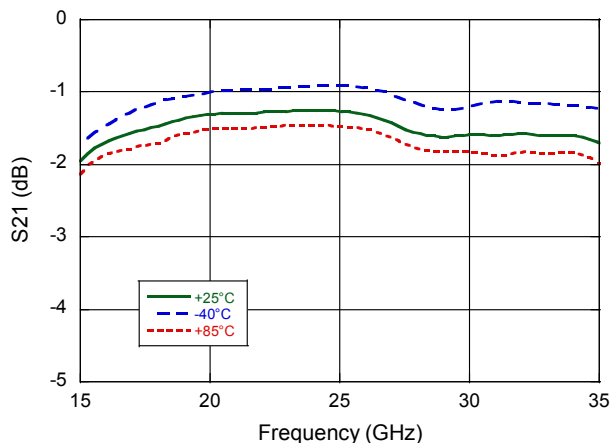

Isolation

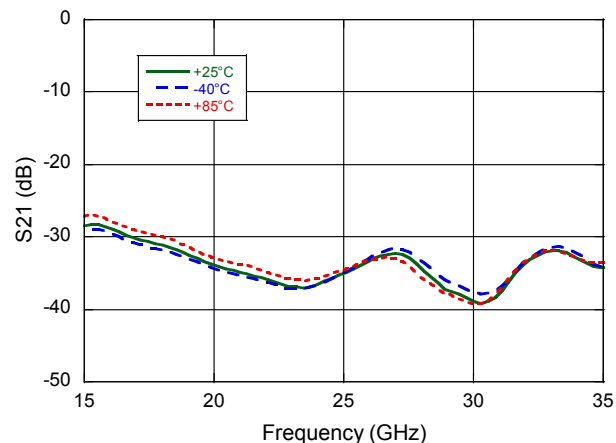

Input Return Loss (RF Common)

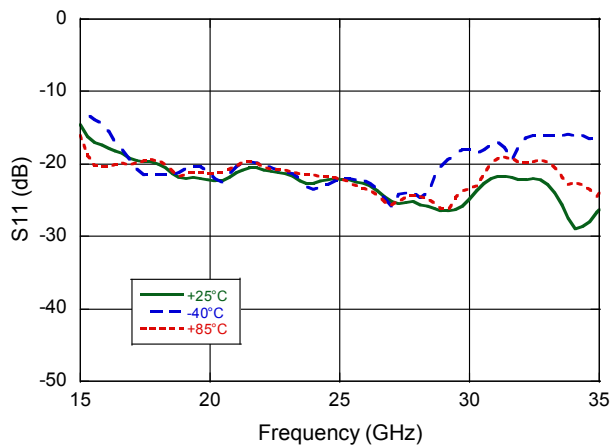

Output Return Loss (On state RF1, RF2)

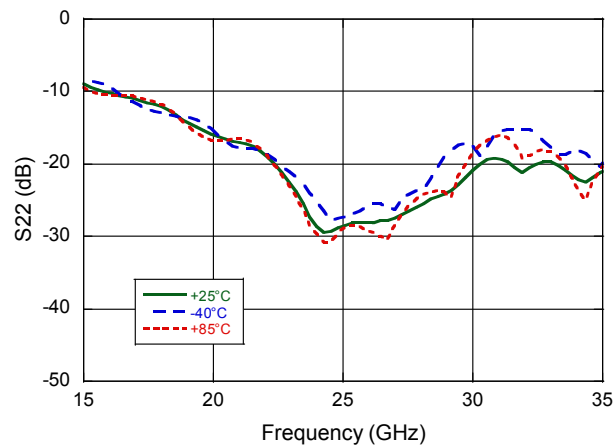

Gain Compression @ 24 GHz

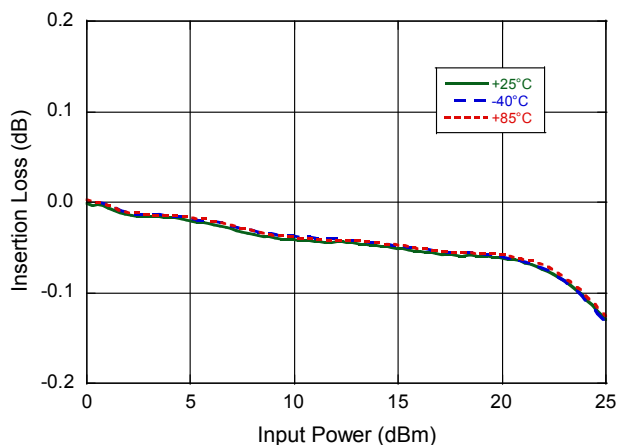

Input IP3

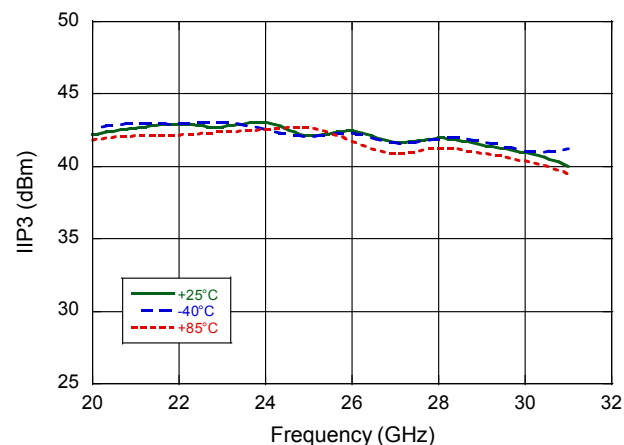

MACOM Technology Solutions Inc. All rights reserved.

Information in this document is provided in connection with MACOM Technology Solutions Inc ("MACOM") products. These materials are provided by MACOM as a service to its customers and may be used for informational purposes only. Except as provided in MACOM's Terms and Conditions of Sale for such products or in any separate agreement related to this document, MACOM assumes no liability whatsoever. MACOM assumes no responsibility for errors or omissions in these materials. MACOM may make changes to specifications and product descriptions at any time, without notice. MACOM makes no commitment to update the information and shall have no responsibility whatsoever for conflicts or incompatibilities arising from future changes to its specifications and product descriptions. No license, express or implied, by estoppel or otherwise, to any intellectual property rights is granted by this document.

THESE MATERIALS ARE PROVIDED "AS IS" WITHOUT WARRANTY OF ANY KIND, EITHER EXPRESS OR IMPLIED, RELATING TO SALE AND/OR USE OF MACOM PRODUCTS INCLUDING LIABILITY OR WARRANTIES RELATING TO FITNESS FOR A PARTICULAR PURPOSE, CONSEQUENTIAL OR INCIDENTAL DAMAGES, MERCHANTABILITY, OR INFRINGEMENT OF ANY PATENT, COPYRIGHT OR OTHER INTELLECTUAL PROPERTY RIGHT. MACOM FURTHER DOES NOT WARRANT THE ACCURACY OR COMPLETENESS OF THE INFORMATION, TEXT, GRAPHICS OR OTHER ITEMS CONTAINED WITHIN THESE MATERIALS. MACOM SHALL NOT BE LIABLE FOR ANY SPECIAL, INDIRECT, INCIDENTAL, OR CONSEQUENTIAL DAMAGES, INCLUDING WITHOUT LIMITATION, LOST REVENUES OR LOST PROFITS, WHICH MAY RESULT FROM THE USE OF THESE MATERIALS.

MACOM products are not intended for use in medical, lifesaving or life sustaining applications. MACOM customers using or selling MACOM products for use in such applications do so at their own risk and agree to fully indemnify MACOM for any damages resulting from such improper use or sale.