

Features

- Very Broadband Performance
- Low Insertion Loss: 1.75 dB Typical @ 18 GHz
- High Isolation: 50 dB Typical @ 18 GHz
- Fast Switching Speed: 2 ns Typical
- Reflective Configuration
- Ultra Low DC Power Consumption
- Via Hole Grounding

Description

M/A-COM's MASW20000 is a versatile, high isolation SPDT switch. Designed on M/A-COM's mature 1-micron MESFET process, this parts is ideal for modules or other packaging for use in the Cellular, GPS, LAN and infrastructure markets.

Demonstrating performance up to 20 GHz, the MASW20000 will perform well in many types of applications within that range.

Ordering Information¹

Part Number	Package
MASW20000	Die

1. Die quantity varies.

Absolute Maximum Ratings²

Parameter	Absolute Maximum
Control Voltage (A1/B2 or A2/B1)	-8.5 VDC
Input RF Power	+34 dBm
Operating Temperature	+175°C
Storage Temperature	-65°C to +175°C

2. Exceeding any one or combination of these limits may cause permanent damage to this device.

Pad Layout

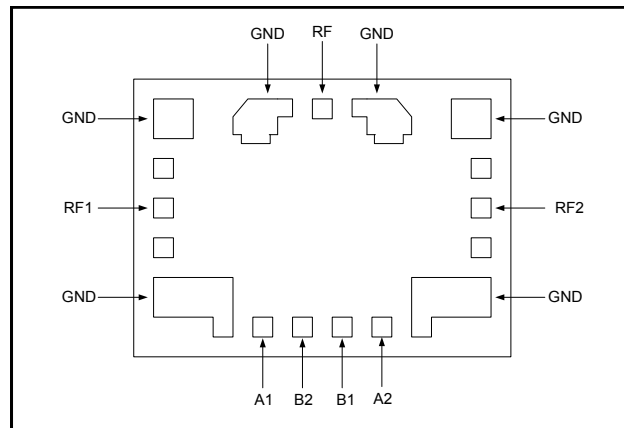

Bond Pad Dimensions

Bond Pad	Dimension Inches (mm)
RF, RF1, RF2	0.004 x 0.004 (0.100 x 0.100)
A1, A2, B1, B2	0.004 x 0.004 (0.100 x 0.100)
DIE Size	0.083 x 0.035 x 0.004 (2.10 x 0.89 x 0.10)

Schematic

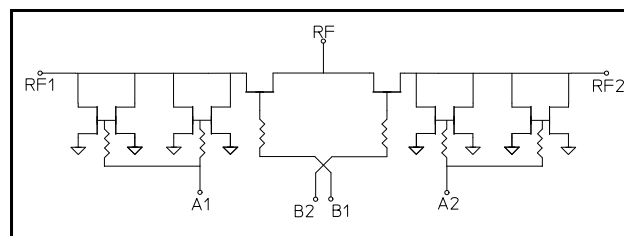

GaAs SPDT Switch DC - 20 GHz

Rev. V5

Electrical Specifications³: $T_A = 25^\circ\text{C}$, $Z_0 = 50\Omega$, $+25^\circ\text{C}$ ⁴

Parameter	Test Conditions	Units	Min.	Typ.	Max.
Insertion Loss	10 GHz	dB	—	1.4	1.7
	18 GHz	dB	—	1.75	2.1
	20 GHz	dB	—	2.0	2.5
Isolation	10 GHz	dB	50	59	—
	18 GHz	dB	42	49	—
	20 GHz	dB	40	47	—
VSWR	10 GHz	Ratio	—	—	1.6:1
	18 GHz	Ratio	—	—	1.8:1
	20 GHz	Ratio	—	—	2.0:1
Trise, Tfall	10% to 90% RF and 90% to 10% RF	ns	—	2	—
Ton, Toff	50% control to 90% RF, and 50% control to 10% RF	ns	—	3	—
Transients	In-Band	mV	—	20	—
Input P1dB	0.5 - 20 GHz, 0 to -5 V	dBm	—	25	—
	0.05 GHz, 0 to -5 V	dBm	—	18	—
IP2	Two Tone, +5 dBm/Tone, 5 MHz Spacing, >50 MHz 0.5 - 20 GHz	dBm	—	+59	—
IIP3	Two Tone, +5 dBm/Tone, 5 MHz Spacing, >50 MHz 0.5 - 20 GHz 0.05 GHz	dBm	—	+43	—
		dBm	—	+27	—
Control Voltage (Complementary Logic)	V_{IN} Low, 0 to -0.2 V	μA	—	—	5
	V_{IN} High, -5 V	μA	—	—	50

3. All specifications apply with 50 Ω impedance connected to all RF ports, 0 and -5 VDC control voltages.

4. Loss changes 0.0025 dB/ $^\circ\text{C}$ (From -55 $^\circ\text{C}$ to +85 $^\circ\text{C}$).

Truth Table^{5,6}

Control Inputs		Condition of Switch	
A1/B2	A2/B1	RF1	RF2
V_{IN} Hi	V_{IN} Low	On	Off
V_{IN} Low	V_{IN} Hi	Off	On

5. V_{IN} Low = 0 to -0.2 V, V_{IN} Hi = -5V

6. For normal SPDT operation A1 is connected to B2 and A2 is connected to B1.

Handling Procedures

Please observe the following precautions to avoid damage:

Static Sensitivity

Gallium Arsenide Integrated Circuits are sensitive to electrostatic discharge (ESD) and can be damaged by static electricity. Proper ESD control techniques should be used when handling these devices.

Typical Performance Curves

Insertion Loss

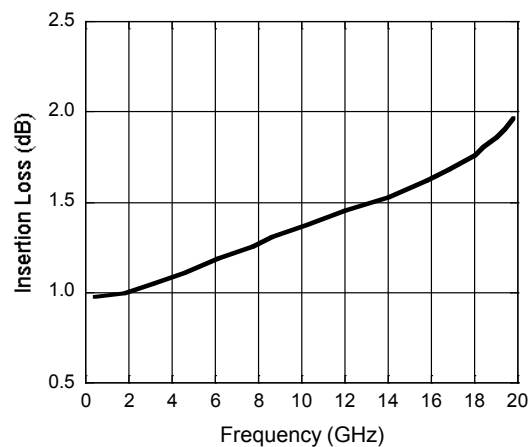

Isolation

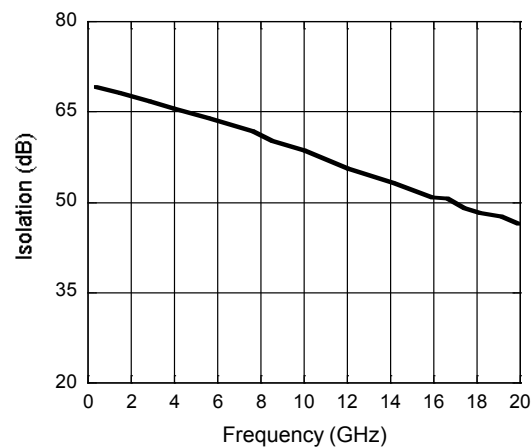

VSWR

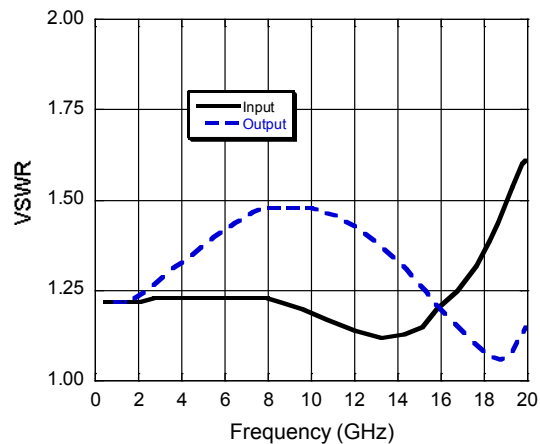

Handling Procedures

Permanent damage to the MASW20000 may occur if the following precautions are not adhered to:

- A. Cleanliness - The MASW20000 should be handled in a clean environment. DO NOT attempt to clean assembly after the MASW20000 is installed.
- B. Static Sensitivity - All die handling equipment and personnel should be DC grounded.
- C. Transients - Avoid instrument and power supply transients while bias is connected to the MASW20000. Use shielded signal and bias cables to minimize inductive pick-up.
- D. Bias - Apply voltage to either control port A1/B2 or A2/B1 only when the other is grounded. Neither port should be allowed to "float".
- E. General Handling - It is recommended that the MASW20000 chip be handled along the long side of the die with a sharp pair of bent tweezers. DO NOT touch the surface of the chip with fingers or tweezers.

Mounting

The MASW20000 is back-metallized with Pd/Ni/Au (100/1,000/30,000Å) metallization. It can be die-mounted using Au/Sn eutectic preforms or a thermally conductive epoxy. The package surface should be clean and flat before attachment.

Eutectic Die Attach:

- A. An 80/20 Au/Sn preform is recommended with a work surface temperature of approximately 255°C and a tool temperature of 265°C. When hot 90/10 nitrogen/hydrogen gas is applied, solder temperature should be approximately 290°C.
- B. DO NOT expose the MASW20000 to a temperature greater than 320°C for more than 20 seconds. No more than 3 seconds of scrubbing should be required for attachment.

Epoxy Die Attach:

- A. Apply a minimum amount of epoxy and place the MASW20000 into position. A thin epoxy fillet should be visible around the perimeter of the die.
- B. Cure epoxy per manufacturer's recommended schedule.
- C. Electrically conductive epoxy is recommended but is not required.

Wire Bonding

- A. Ball or wedge bond with 1.0 mil diameter pure gold wire. Gold ribbon (3.0 mil x 0.5 mil) may also be used. Thermo sonic wire bonding with a nominal stage temperature of 150°C and a ball bonding force of 40 to 50 grams or wedge bonding force of 18 to 22 grams is recommended. Ultrasonic energy and time should be adjusted to the minimum levels to achieve reliable wirebonds.
- B. Wirebonds should be started on the chip and terminated on the package.

M/A-COM Technology Solutions Inc. All rights reserved.

Information in this document is provided in connection with M/A-COM Technology Solutions Inc ("MACOM") products. These materials are provided by MACOM as a service to its customers and may be used for informational purposes only. Except as provided in MACOM's Terms and Conditions of Sale for such products or in any separate agreement related to this document, MACOM assumes no liability whatsoever. MACOM assumes no responsibility for errors or omissions in these materials. MACOM may make changes to specifications and product descriptions at any time, without notice. MACOM makes no commitment to update the information and shall have no responsibility whatsoever for conflicts or incompatibilities arising from future changes to its specifications and product descriptions. No license, express or implied, by estoppel or otherwise, to any intellectual property rights is granted by this document.

THESE MATERIALS ARE PROVIDED "AS IS" WITHOUT WARRANTY OF ANY KIND, EITHER EXPRESS OR IMPLIED, RELATING TO SALE AND/OR USE OF MACOM PRODUCTS INCLUDING LIABILITY OR WARRANTIES RELATING TO FITNESS FOR A PARTICULAR PURPOSE, CONSEQUENTIAL OR INCIDENTAL DAMAGES, MERCHANTABILITY, OR INFRINGEMENT OF ANY PATENT, COPYRIGHT OR OTHER INTELLECTUAL PROPERTY RIGHT. MACOM FURTHER DOES NOT WARRANT THE ACCURACY OR COMPLETENESS OF THE INFORMATION, TEXT, GRAPHICS OR OTHER ITEMS CONTAINED WITHIN THESE MATERIALS. MACOM SHALL NOT BE LIABLE FOR ANY SPECIAL, INDIRECT, INCIDENTAL, OR CONSEQUENTIAL DAMAGES, INCLUDING WITHOUT LIMITATION, LOST REVENUES OR LOST PROFITS, WHICH MAY RESULT FROM THE USE OF THESE MATERIALS.

MACOM products are not intended for use in medical, lifesaving or life sustaining applications. MACOM customers using or selling MACOM products for use in such applications do so at their own risk and agree to fully indemnify MACOM for any damages resulting from such improper use or sale.

5

M/A-COM Technology Solutions Inc. (MACOM) and its affiliates reserve the right to make changes to the product(s) or information contained herein without notice.
Visit www.macom.com for additional data sheets and product information.