

## GaAs DPDT Switch DC - 6.0 GHz

Rev. V3

### Features

- Low Insertion Loss, 0.5 dB Typical
- Fast Switching Speed, 4 ns Typical
- Ultra Low DC Power Consumption
- RoHS\* Compliant

### Description

MACOM's MASW6030G is a GaAs MMIC DPDT switch die. The MASW6030G is ideally used where low power consumption is required.

Typical applications include transmit / receive switching, switch matrices and switched filter banks, WLAN IEEE 802.11a and 802.11 b/g systems. Other applications include cordless phones and base stations.

### Ordering Information

Part Number	Package
MASW6030G	DIE <sup>1</sup>

1. Die quantity varies.

### Absolute Maximum Rating <sup>2,3</sup>

Parameter	Absolute Maximum
Control Value (A or B)	0/-8 V
Max Input RF Power	+34 dBm (0.5 - 6.0 GHz with 0/-8 V CTL)
Storage Temperature	-65°C to +175°C
Max Operating Temperature	+175°C

2. Exceeding any one or combination of these limits may cause permanent damage to this device.
3. M/A-COM does not recommend sustained operation near these survivability limits.

### Truth Table <sup>4,5</sup>

		RF1 to		RF6 to	
A	B	RF2	RF3	RF4	RF5
1	0	On	Off	On	Off
0	1	Off	On	Off	On

4. 0 = 0 to -0.2 V, 1 = -5 V.
5. When an RF output port is "Off" it is shorted to ground through an "On" shunt MESFET.

\*Restrictions on Hazardous Substances, European Union Directive 2002/95/EC.

### Pad Layout

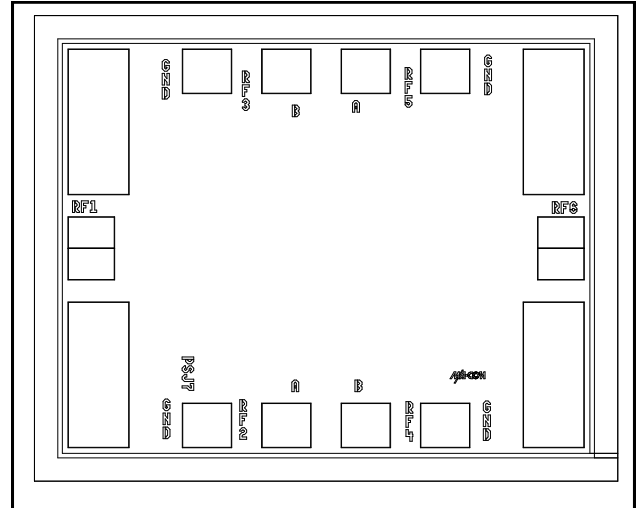

### Die Size - Inches (mm)

0.048 x 0.038 x 0.010 (1.220 x 0.970 x 0.250)

### Bond Pad Dimensions

Bond Pad	Dimensions - Inches (mm)
RF1, RF6	0.005 x 0.005 (0.130 x 0.150)
RF2, RF3, RF4, RF5, A, B	0.004 x 0.004 (0.100 x 0.100)
GND	0.005 x 0.013 (0.130 x 0.320)

### Schematic

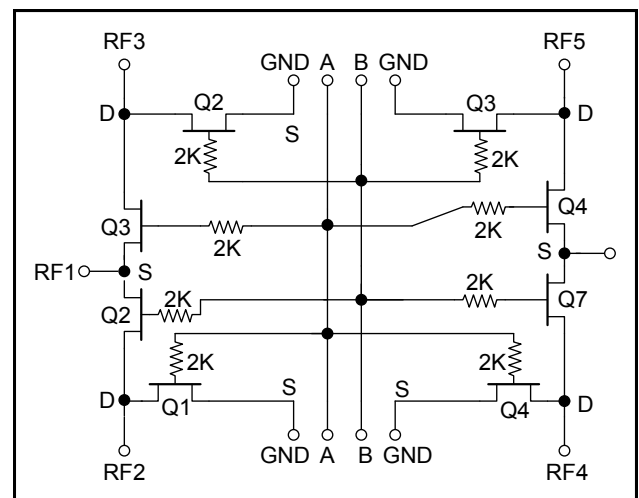

**Electrical Specifications: +25°C, 0/5 Vdc, 50 Ω**

Parameter	Test Conditions	Units	Min.	Typ.	Max.
Insertion Loss <sup>6</sup>	DC - 1.0 GHz	dB	—	—	0.6
	DC - 2.0 GHz	dB	—	—	0.8
	DC - 4.0 GHz	dB	—	—	1.0
	DC - 6.0 GHz	dB	—	—	1.5
Isolation	DC - 1.0 GHz	dB	40	—	—
	DC - 2.0 GHz	dB	35	—	—
	DC - 4.0 GHz	dB	25	—	—
	DC - 6.0 GHz	dB	20	—	—
VSWR	DC - 1.0 GHz	Ratio	—	—	1.2:1
	DC - 2.0 GHz	Ratio	—	—	1.4:1
	DC - 4.0 GHz	Ratio	—	—	1.5:1
	DC - 6.0 GHz	Ratio	—	—	1.8:1
Input P-1dB	0.5 - 6.0 GHz, 0 / -5V, 0 / -8V	dBm	—	+27 / +33	—
	0.05 GHz, 0 / -5V, 0 / -8V	dBm	—	+21 / +26	—
IP2	Two Tone Input Power up to +5 dBm	dBm	—	+68	—
	0.5 - 6.0 GHz 0.05 GHz	dBm	—	+62	—
IP3	Two Tone Input Power up to +5 dBm	dBm	—	+45	—
	0.5 - 6.0 GHz 0.05 GHz	dBm	—	+40	—
Control Current	V <sub>IN</sub> Low (0 to -0.2 V)	μA	—	—	5
	V <sub>OUT</sub> High (-5 V @ 10 μA Typ to -8 V)	μA	—	—	100
T-rise, T-fall	10% to 90% RF and 90% to 10% RF	nS	—	2	—
T <sub>ON</sub> , T <sub>OFF</sub>	50% control to 90% RF, and 50% control to 10% RF	nS	—	4	—
Transients	In Band	mV	—	15	—

6. Loss changes 0.0025 dB/°C (-55°C to +85°C.)

## Handling Procedures

Please observe the following precautions to avoid damage:

## Static Sensitivity

Gallium Arsenide Integrated Circuits are sensitive to electrostatic discharge (ESD) and can be damaged by static electricity. Proper ESD control techniques should be used when handling these devices.

## Typical Performance

### Insertion Loss

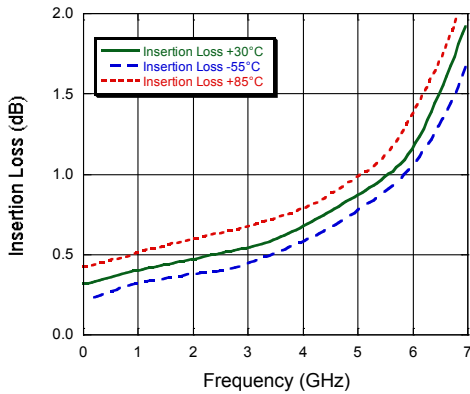

### VSWR @ 25°C

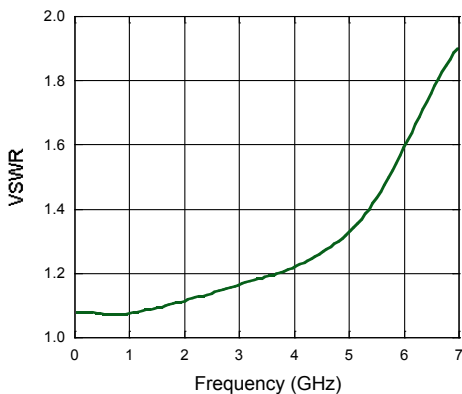

### Isolation @ 25°C

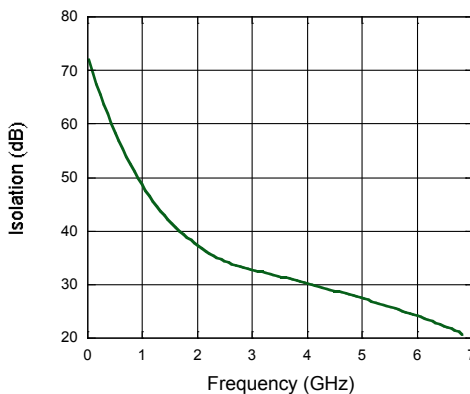

## Handling Precautions

Permanent damage to the MASW6030G may occur if the following precautions are not adhered to:

- Cleanliness - MASW6030G should be handled in a clean environment. DO NOT attempt to clean unit after the MASW6030G is installed.
- Static Sensitivity—All chip handling equipment and personnel should be DC grounded.
- Transient - Avoid instrument and power supply transients while bias is applied to the MASW6030G. Use shielded signal and bias cables to minimize inductive pick-up.
- Bias - Apply voltage to either of the complementary control ports only when the other is grounded. No port should be allowed to “float”.
- General Handling - It is recommended that the MASW6030G chip be handled along the long side of the die with a sharp pair of bent tweezers. DO NOT touch the surface of the chip with fingers or tweezers.

## Wire Bonding

- Ball or wedge with 1.0 mil diameter pure gold wire. Thermosonic wirebonding with a nominal stage temperature of 150°C and a ball bonding force of 40 to 50 grams or wedge bonding force of 18 to 22 grams is recommended. Ultrasonic energy and time should be adjusted to the minimum levels achieve reliable wirebonds.
- Wirebonds should be started on the chip and terminated on the package.

## Mounting

The MASW6030G is back-metallized with Pd/Ni/Au (100/1,000, 10,000 Å) metallization. It can be die-mounted with AuSn eutectic preforms or with thermally conductive epoxy. The package surface should be clean and flat before attachment.

### Eutectic Die Attach:

- A. A 80/20 gold/tin preform is recommended with a work surface temperature of approximately 255°C and a tool temperature of 265°C. When not 90/10 nitrogen/hydrogen gas is applied, tool tip temperature should be approximately 290°C.
- B. DO NOT expose the MASW6030G to a temperature greater than 320°C for more than 20 seconds. No more than 3 seconds for scrubbing should be required for attachment.

### Epoxy Die Attach:

- A. Apply a minimum amount of epoxy and place the MASW6030G into position. A thin epoxy fillet should be visible around the perimeter of the chip.
- B. Cure epoxy per manufacturer's recommended schedule.
- C. Electrically conductive epoxy may be used by is not required.

M/A-COM Technology Solutions Inc. All rights reserved.

Information in this document is provided in connection with M/A-COM Technology Solutions Inc ("MACOM") products. These materials are provided by MACOM as a service to its customers and may be used for informational purposes only. Except as provided in MACOM's Terms and Conditions of Sale for such products or in any separate agreement related to this document, MACOM assumes no liability whatsoever. MACOM assumes no responsibility for errors or omissions in these materials. MACOM may make changes to specifications and product descriptions at any time, without notice. MACOM makes no commitment to update the information and shall have no responsibility whatsoever for conflicts or incompatibilities arising from future changes to its specifications and product descriptions. No license, express or implied, by estoppel or otherwise, to any intellectual property rights is granted by this document.

THESE MATERIALS ARE PROVIDED "AS IS" WITHOUT WARRANTY OF ANY KIND, EITHER EXPRESS OR IMPLIED, RELATING TO SALE AND/OR USE OF MACOM PRODUCTS INCLUDING LIABILITY OR WARRANTIES RELATING TO FITNESS FOR A PARTICULAR PURPOSE, CONSEQUENTIAL OR INCIDENTAL DAMAGES, MERCHANTABILITY, OR INFRINGEMENT OF ANY PATENT, COPYRIGHT OR OTHER INTELLECTUAL PROPERTY RIGHT. MACOM FURTHER DOES NOT WARRANT THE ACCURACY OR COMPLETENESS OF THE INFORMATION, TEXT, GRAPHICS OR OTHER ITEMS CONTAINED WITHIN THESE MATERIALS. MACOM SHALL NOT BE LIABLE FOR ANY SPECIAL, INDIRECT, INCIDENTAL, OR CONSEQUENTIAL DAMAGES, INCLUDING WITHOUT LIMITATION, LOST REVENUES OR LOST PROFITS, WHICH MAY RESULT FROM THE USE OF THESE MATERIALS.

MACOM products are not intended for use in medical, lifesaving or life sustaining applications. MACOM customers using or selling MACOM products for use in such applications do so at their own risk and agree to fully indemnify MACOM for any damages resulting from such improper use or sale.