

**GaAs SP4T 2.5 V High Power Switch
DC - 3.0 GHz**

**MASWSS0118
V2**

Features

- Low Voltage Operation: 2.5 V
- Low Harmonics: < -65 dBc at +34 dBm & 1 GHz
- Low Insertion Loss: 0.65 dB at 1 GHz
- High Isolation: 23 dB at 2 GHz
- 4 mm 16-Lead PQFN Package
- 0.5 micron GaAs PHEMT Process

Description

M/A-COM's MASWSS0118 is a GaAs PHEMT MMIC single pole four throw (SP4T) high power switch in a low cost 4 mm 16-lead PQFN package. The MASWSS0118 is ideally suited for applications where high power, low control voltage, low insertion loss, high isolation, small size, and low cost are required.

Typical applications are for GSM and DCS handset systems that connect separate transmit and receive functions to a common antenna, as well as other handset and related applications. This part can be used in all systems operating up to 3.0 GHz requiring high power at low control voltage.

The MASWSS0118 is fabricated using a 0.5 micron gate length GaAs PHEMT process. The process features full passivation for performance and reliability.

Ordering Information

Part Number	Package
MASWSS0118TR	1000 piece reel
MASWSS0118TR-3000	3000 piece reel
MASWSS0118SMB	Sample Test Board

1. Reference Application Note M513 for reel size information.

Functional Schematic

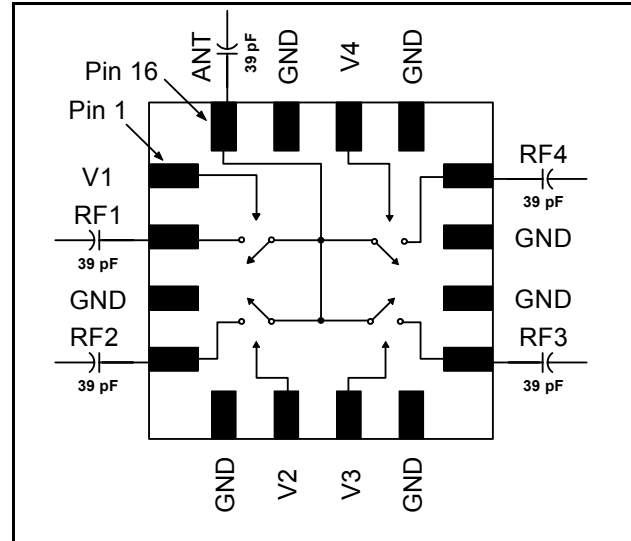

Pin Configuration

Pin No.	Pin Name	Description
1	V1	Control 1
2	RF1	RF Port 1
3	GND	RF Ground
4	RF2	RF Port 2
5	GND	RF Ground
6	V2	Control 2
7	V3	Control 3
8	GND	RF Ground
9	RF3	RF Port 3
10	GND	RF Ground
11	GND	RF Ground
12	RF4	RF Port 4
13	GND	RF Ground
14	V4	Control 4
15	GND	RF Ground
16	ANT	Antenna Port
17	Paddle ²	RF Ground

2. The exposed pad centered on the package bottom must be connected to RF and DC ground.

**GaAs SP4T 2.5 V High Power Switch
DC - 3.0 GHz**

**MASWSS0118
V2**

Electrical Specifications: $T_A = 25^\circ\text{C}$, $Z_0 = 50 \Omega$ ³

Parameter	Test Conditions	Units	Min.	Typ.	Max.
Insertion Loss ⁴	DC – 1 GHz	dB	—	0.65	0.85
	1 – 2 GHz	dB	—	0.80	1.00
	2 – 3 GHz	dB	—	1.00	—
Isolation	DC – 1 GHz	dB	27	29.0	—
	1 – 2 GHz	dB	21	23.0	—
	2 – 3 GHz	dB	—	18.5	—
Return Loss	DC – 3 GHz	dB	—	20	—
IP3	Two Tone +26 dBm, 5 MHz Spacing, > 50 MHz $V_C = 0 \text{ V} / 2.5 \text{ V}$	dBm	—	57	—
IP2	Two Tone +26 dBm, 5 MHz Spacing, > 50 MHz $V_C = 0 \text{ V} / 2.5 \text{ V}$	dBm	—	81	—
P.1dB	$V_C = 0 \text{ V} / 2.5 \text{ V}$	dBm	—	38	—
2 nd Harmonic	1 GHz, $P_{IN} = +34 \text{ dBm}$, $V_C = 0 \text{ V} / 2.5 \text{ V}$	dBc	—	-80	-71
3 rd Harmonic	1 GHz, $P_{IN} = +34 \text{ dBm}$, $V_C = 0 \text{ V} / 2.5 \text{ V}$	dBc	—	-68	-65
Trise, Tfall	10% RF to 90% RF, 90% to 10% RF, $V_C = 0 \text{ V} / 2.5 \text{ V}$	μS	—	0.2	—
Ton, Toff	50% control to 90% RF, 50% control to 10% RF, $V_C = 0 \text{ V} / 2.5 \text{ V}$	μS	—	0.2	—
Transients		mV	—	35	—
Control Current	$V_C = 0 \text{ V} / 2.5 \text{ V}$, 34 dBm	μA	—	10	50

3. External DC blocking capacitors are required on all RF ports.

4. Insertion Loss can be optimized by varying the DC blocking capacitor value, e.g. 1000 pF for 100 MHz - 500 MHz, 39 pF for 0.5 GHz - 3 GHz.

Absolute Maximum Ratings ^{5,6}

Parameter	Absolute Maximum
Input Power (0.5 - 3.0 GHz, 2.5 V Control)	+38 dBm
Voltage	± 8.5 volts
Operating Temperature	-40°C to $+85^\circ\text{C}$
Storage Temperature	-65°C to $+150^\circ\text{C}$

5. Exceeding any one or combination of these limits may cause permanent damage to this device.

6. M/A-COM does not recommend sustained operation near these survivability limits.

Truth Table ^{7,8}

V1	V2	V3	V4	ANT-RF1	ANT-RF2	ANT-RF3	ANT-RF4
1	0	0	0	On	Off	Off	Off
0	1	0	0	Off	On	Off	Off
0	0	1	0	Off	Off	On	Off
0	0	0	1	Off	Off	Off	On

7. Differential voltage, V (state 1) - V (state 2), must be 2.5 V minimum.

8. 0 = -5 V to +2.5 V, 1 = -2.5 V to +5 V

Handling Procedures

Please observe the following precautions to avoid damage:

Static Sensitivity

Gallium Arsenide Integrated Circuits are sensitive to electrostatic discharge (ESD) and can be damaged by static electricity. Proper ESD control techniques should be used when handling these devices.

**GaAs SP4T 2.5 V High Power Switch
DC - 3.0 GHz**

**MASWSS0118
V2**

Typical Performance Curves

Insertion Loss vs. Temperature

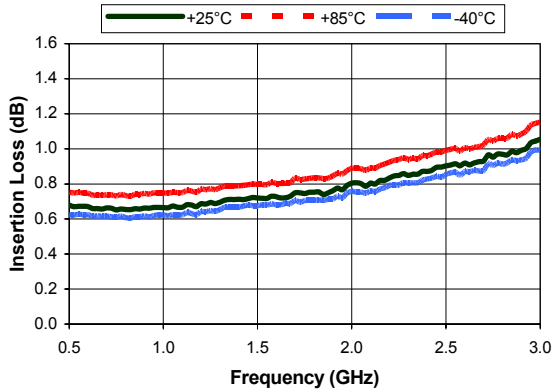

Isolation vs. Temperature

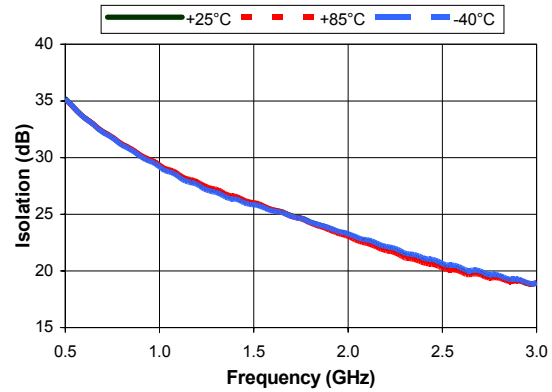

1 GHz 2nd Harmonic Rejection

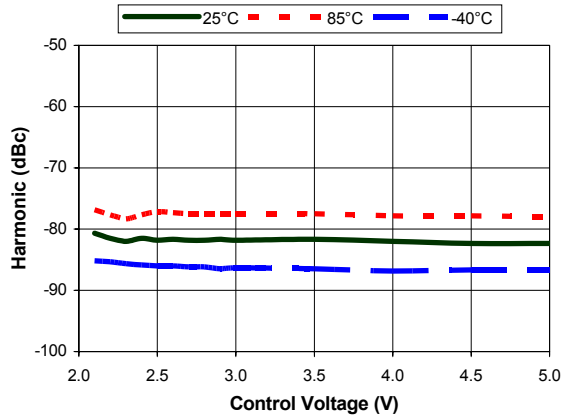

1 GHz 3rd Harmonic Rejection

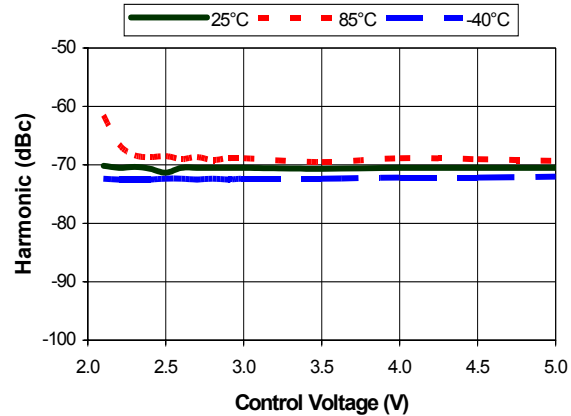

4 mm 16-Lead PQFN

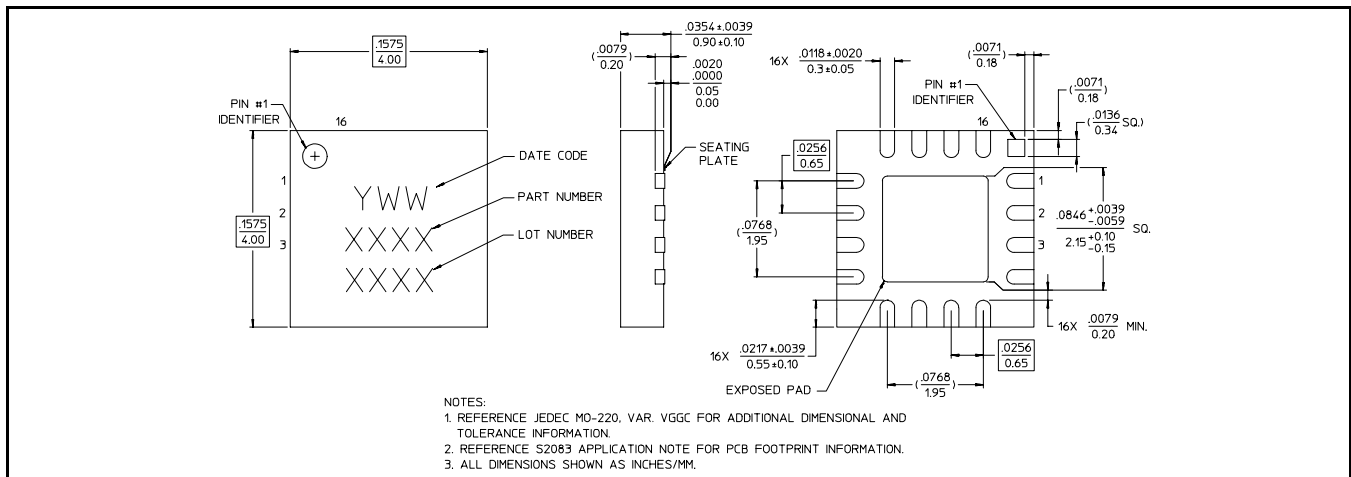

M/A-COM Inc. and its affiliates reserve the right to make changes to the product(s) or information contained herein without notice. M/A-COM makes no warranty, representation or guarantee regarding the suitability of its products for any particular purpose, nor does M/A-COM assume any liability whatsoever arising out of the use or application of any product(s) or information.

- **North America** Tel: 800.366.2266 / Fax: 978.366.2266
- **Europe** Tel: 44.1908.574.200 / Fax: 44.1908.574.300
- **Asia/Pacific** Tel: 81.44.844.8296 / Fax: 81.44.844.8298

Visit www.macom.com for additional data sheets and product information.