

Low Power, 3½ Digit A/D Converter with Display Hold

General Description

The MAX136 is a monolithic analog-to-digital converter (ADC) with very high input impedance. It differs from the Maxim ICL7136 in that the MAX136 provides a Hold pin, which makes it possible to hold or "freeze" a reading. The MAX136 directly drives a nonmultiplexed liquid crystal (LCD) display, requiring no external drive circuitry. With minor external component changes, it is pin compatible with the ICL7116 but with significantly reduced power consumption, making the MAX136 a superior device for portable systems.

Versatility and accuracy are inherent features of this ADC. The dual-slope conversion technique automatically rejects interference signals common in industrial environments. True differential inputs allow direct measurements of bridge transducer outputs or load cells. The zero-integrator phase eliminates overrange hangover and hysteresis effects. The MAX136 offers high accuracy by lowering rollover error to less than one count and zero reading drift to less than 1µV/°C.

Applications

These devices can be used in a wide range of digital panel meter applications. Most applications, however, involve the measurement and display of analog data:

- | | |
|-------------|--------------------|
| Pressure | Conductance |
| Voltage | Current |
| Resistance | Speed |
| Temperature | Material Thickness |

Typical Operating Circuit

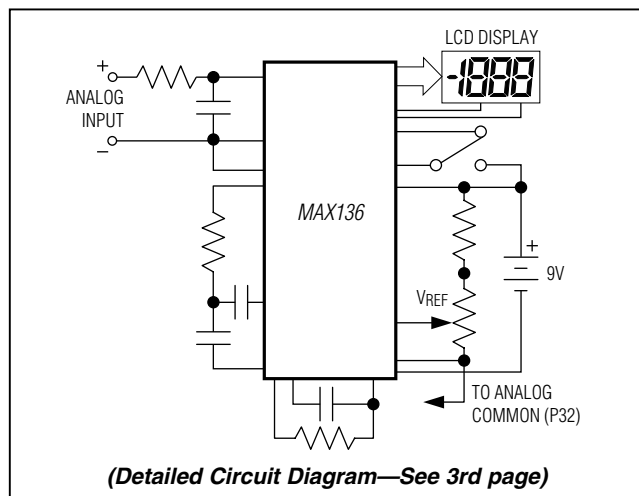

Features

- Power Dissipation Guaranteed Less than 1mW—9V Battery Life 3000 Hours Typical
- Hold Pin Allows Indefinite Display Hold
- Guaranteed First Reading Recovery from Overrange
- On-Board Display Drive Capability—No External Circuitry Required
- High-Impedance CMOS Differential Inputs
- Low Noise (< 15µVp-p) Without Hysteresis or Overrange Hangover
- Clock and Reference On-Chip
- Zero Input Gives Zero Reading
- True Polarity Indication for Precision Null Applications
- Key Parameters Guaranteed Over Temperature

Ordering Information

PART	TEMP RANGE	PIN-PACKAGE
MAX136CPL+	0°C to +70°C	40 PDIP
MAX136CMH+	0°C to +70°C	44 MQFP
MAX136CQH+	0°C to +70°C	44 PLCC
MAX136C/D	0°C to +70°C	Dice

+Denotes a lead(Pb)-free/RoHS-compliant package.

Pin Configurations

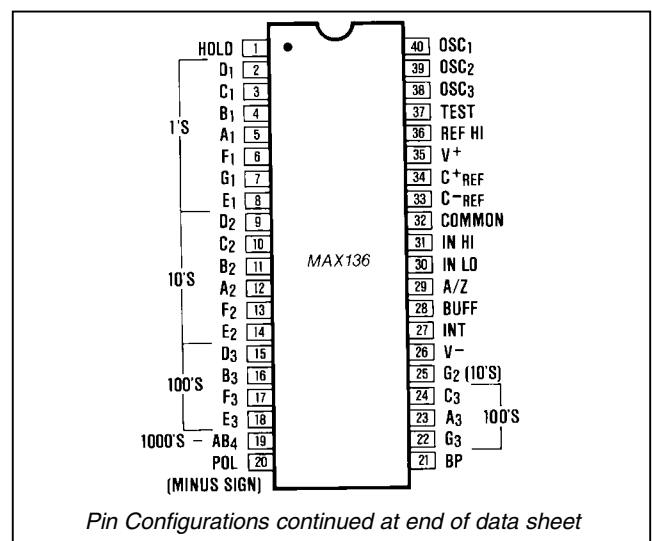

MAX136

Low Power, 3½ Digit A/D Converter with Display Hold

ABSOLUTE MAXIMUM RATINGS

Supply Voltage (V+ to V-)	15V	Power Dissipation (Note 2)	
Analog Input Voltage (either input) (Note 1).....	V+ to V-	PDIP.....	800mW
Reference Input Voltage (either input).....	V+ to V-	Operating Temperature Range	0°C to +70°C
Clock Input, Hold Input.....	TEST to V+	Storage Temperature	-65°C to +160°C
		Lead Temperature (soldering, 60s)	+300°C

Note 1: Input voltages may exceed the supply voltages, provided the input current is limited to ±1mA.

Note 2: Dissipation rating assumes device is mounted with all leads soldered to printed circuit board.

ELECTRICAL CHARACTERISTICS

(V⁺ = 9V; T_A = 25°C; f_{CLOCK} = 48kHz; test circuit - Figure 1 unless noted.)

PARAMETERS	CONDITIONS	MIN	TYP	MAX	UNITS
Zero Input Reading	V _{IN} = 0.0V, Full Scale = 200.0mV T _A = 25°C (Note 3) 0° ≤ T _A ≤ 70°C (Note 6)	-000.0 -000.0	±000.0 ±000.0	+000.0 +000.0	Digital Reading
Ratiometric Reading	V _{IN} = V _{REF} , V _{REF} = 100mV T _A = 25°C (Note 3) 0° ≤ T _A ≤ 70°C (Note 6)	999 998	999/1000 999/1000	1000 1001	Digital Reading
Rollover Error (Difference in reading for equal positive and negative reading near Full Scale)	-V _{IN} = +V _{IN} = 200.0mV T _A = 25°C (Note 3) 0° ≤ T _A ≤ 70°C (Note 6)	-1	±0.2 ±0.2	+1	Counts
Linearity (Max. deviation from best straight line fit)	Full Scale = 200.0mV or full scale = 2.000V	-1	±0.2	+1	Counts
Common Mode Rejection Ratio (Note 7)	V _{CM} = ± 1V, V _{IN} = 0V Full Scale = 200.0mV		5		μV/V
Noise (Pk-Pk value not exceeded 95% of time)	V _{IN} = 0V Full Scale = 200.0mV		10		μV
Input Leakage Current	V _{IN} = 0, T _A = 25°C (Note 3) 0° ≤ T _A ≤ 70°C		1 20	10 200	pA
Zero Reading Drift	V _{IN} = 0, 0° ≤ T _A ≤ 70°C (Note 6)		0.2	1	μV/°C
Scale Factor Temperature Coefficient	V _{IN} = 199.0mV 0° ≤ T _A ≤ 70°C (Ext. Ref. 0ppm/°C) (Note 6)		1	5	ppm/°C
V ⁺ Supply Current	V _{IN} = 0 T _A = 25°C 0° ≤ T _A ≤ 70°C		80	150 200	μA
Analog Common Voltage (with respect to Pos. supply)	250kΩ between Common & Pos. Supply	2.6	2.8	3.2	V
Temp. Coeff. of Analog Common (with respect to Pos. Supply)	250kΩ between Common & Pos. Supply		75		ppm/°C
Input Resistance, Pin 1			1000		MΩ
V _{IL} , Pin 1				TEST +1.5	V
V _{IH} , Pin 1		V ⁺ -1.5			V
Pk-Pk Segment Drive Voltage	V ⁺ to V ⁻ = 9V (Note 8)	4	5	6	V
Pk-Pk Backplane Drive Voltage					
Test Pin Voltage	With Respect to V ⁺	4	5	6	V
Overload Recovery Time (Note 5)	V _{IN} changing from ± 10V to 0V		0	1	Measurement Cycles

Note 3: Test condition is V_{IN} applied between pins IN-HI and IN-LO, i.e., 1MΩ resistor in Figures 1 and 2.

Note 4: All pins are designed to withstand electrostatic discharge (ESD) levels in excess of 2000V. (Test circuit per Mil. Std. 883C, Method 3015.2)

Note 5: Number of measurement cycles for display to give accurate reading.

Note 6: 1MΩ resistor is removed in Figures 1 and 2.

Note 7: Refer to "Differential Input" discussion (See Maxim's ICL7136 data sheet).

Note 8: Back plane drive is in phase with segment drive for 'off' segment, 180° out of phase for 'on' segment. Frequency is 20 times conversion rate. Average DC component is less than 50mV.

MAX136

Low Power, 3½ Digit A/D Converter with Display Hold

Detailed Description

The MAX136 3½ digit ADC is similar to the Maxim ICL7136 except for the addition of a Hold pin. For a detailed product description, and applications information (other than the operation of the Hold pin described below), refer to Maxim's ICL7136 data sheet.

Hold Input

The Hold input is a digital input with a logic threshold approximately midway between V+ and Test. The MAX136 continuously performs conversions, independent of the Hold input. When the Hold input is at V+ the display latch pulse is inhibited, and the display latches

are not updated; when the Hold input is low or at the Test voltage, the display is updated at the end of each conversion. The MAX136 maintains low-power dissipation even during display hold by eliminating the pull-down resistor between Hold and Test present on the ICL7116. The Hold input is CMOS compatible, and can also be driven by a switch connected between Test and V+ (Figure 1).

Reference Input

Unlike the ICL7136, the MAX136 does not have a reference low input. Apply the reference voltage between Reference High (REF HI) and

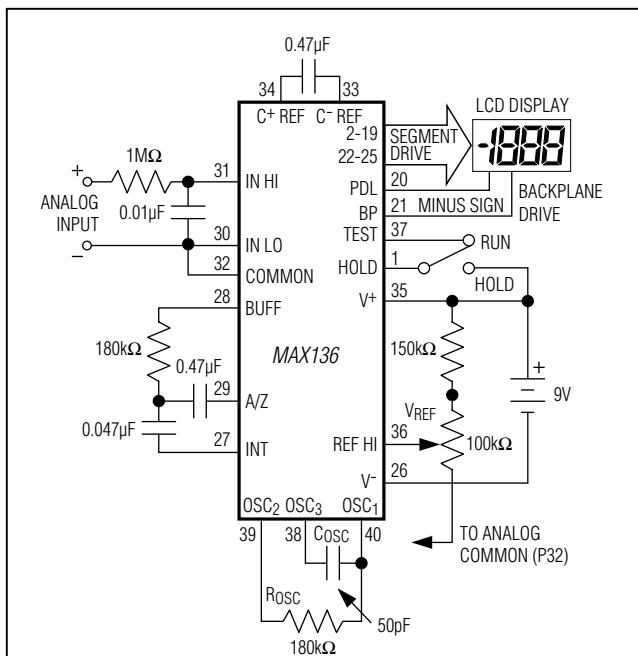

Figure 1. MAX136 Typical Operating Circuit, 200mV Full Scale

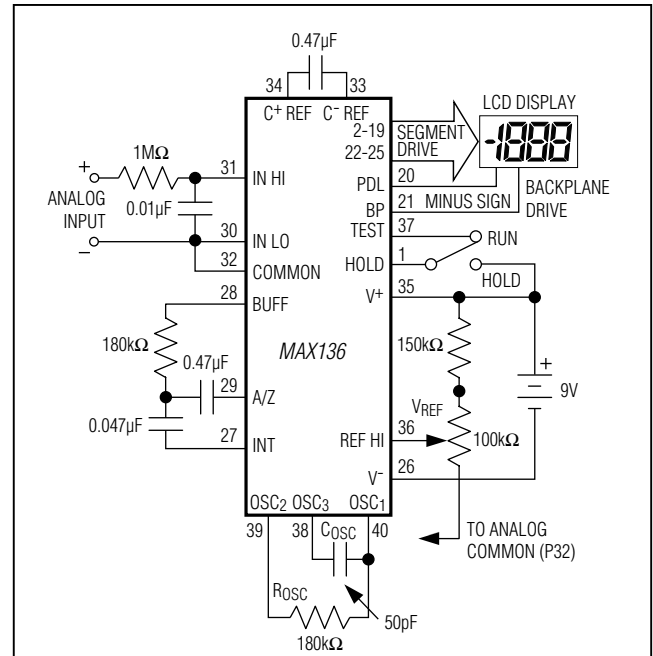
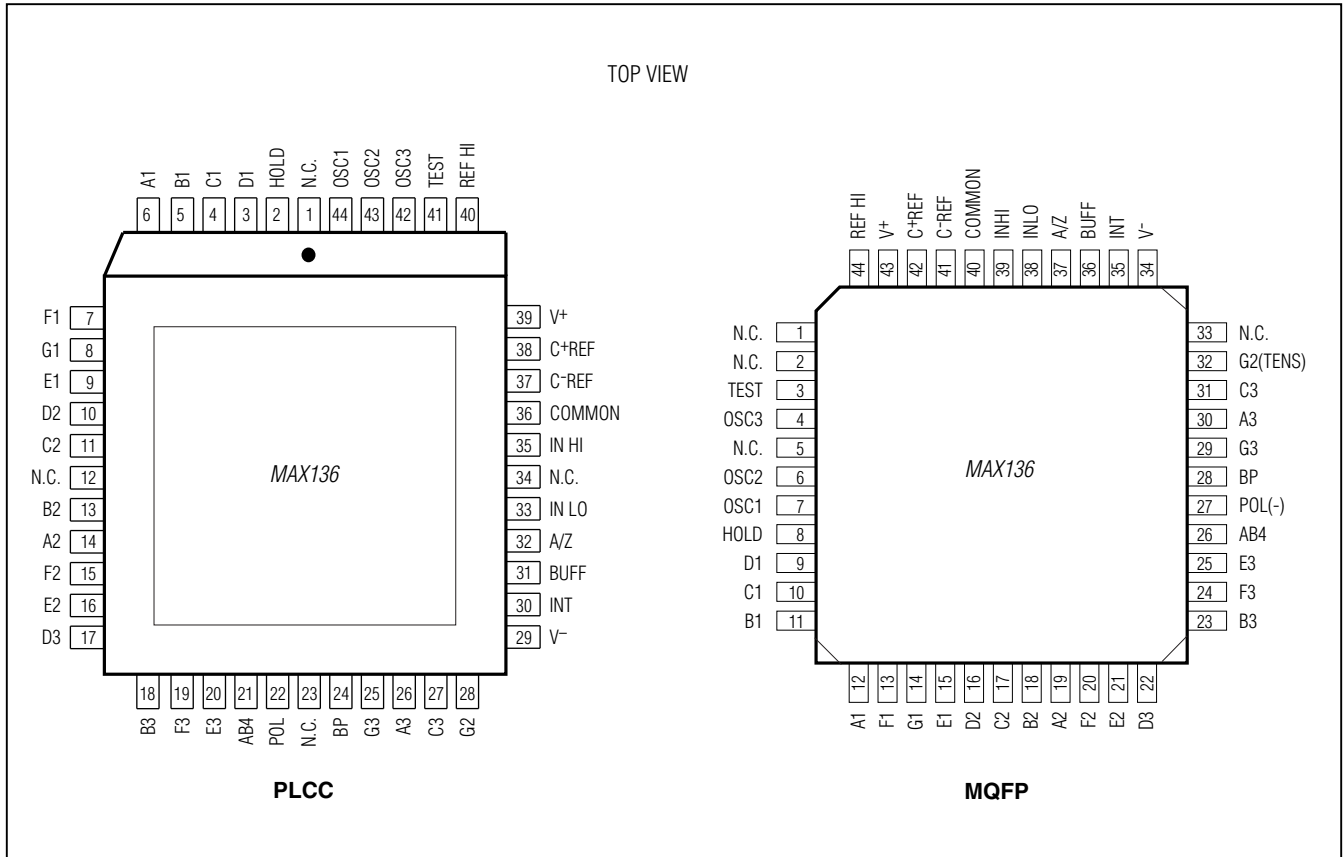

Figure 2. MAX136 Typical Operating Circuit, 2.0V Full Scale

MAX136

Low Power, 3½ Digit A/D Converter with Display Hold

Pin Configurations (continued)



Package Information

For the latest package outline information and land patterns (footprints), go to www.maximintegrated.com/packages. Note that a “+”, “#”, or “-” in the package code indicates RoHS status only. Package drawings may show a different suffix character, but the drawing pertains to the package regardless of RoHS status.

PART TYPE	PACKAGE CODE	DOCUMENT NO.	LAND PATTERN No.
40 PDIP	P40+1	21-0044	—
44 PLCC	Q44+1	21-0049	90-0236
44 MQFP	M44+5	21-0826	90-0169

MAX136

Low Power, 3½ Digit A/D Converter with Display Hold

Revision History

REVISION NUMBER	REVISION DATE	DESCRIPTION	PAGES CHANGED
0	2/87	Initial release	—
1	11/12	Add MQFP package to <i>Ordering Information</i> and <i>Package Information</i> .	1, 4



Maxim Integrated cannot assume responsibility for use of any circuitry other than circuitry entirely embodied in a Maxim Integrated product. No circuit patent licenses are implied. Maxim Integrated reserves the right to change the circuitry and specifications without notice at any time. The parametric values (min and max limits) shown in the Electrical Characteristics table are guaranteed. Other parametric values quoted in this data sheet are provided for guidance.

Maxim Integrated 160 Rio Robles, San Jose, CA 95134 USA 1-408-601-1000

5