

MAXIM

Buck/Boost Regulating Charge Pump in μ MAX

MAX1759

General Description

The MAX1759 is a buck/boost regulating charge pump that generates a regulated output voltage from a single lithium-ion (Li+) cell, or two or three NiMH or alkaline cells for small hand-held portable equipment. The MAX1759 operates over a wide +1.6V to +5.5V input voltage range and generates a fixed 3.3V or adjustable (2.5V to 5.5V) output (Dual Mode™). Maxim's unique charge-pump architecture allows the input voltage to be higher or lower than the regulated output voltage. Despite its high 1.5MHz operating frequency, the MAX1759 maintains low 50 μ A quiescent supply current.

Designed to be an extremely compact buck/boost converter, this device requires only three small ceramic capacitors to build a complete DC-DC converter capable of generating a guaranteed 100mA (min) output current from a +2.5V input. For added flexibility, the MAX1759 also includes an open-drain power-OK (POK) output that signals when the output voltage is in regulation.

The MAX1759 is available in a space-saving 10-pin μ MAX package that is 1.09mm high and half the size of an 8-pin SO.

Applications

Li+ Battery-Powered Applications
Miniature Equipment
Backup Battery Boost Converters
Translators

Typical Operating Circuit

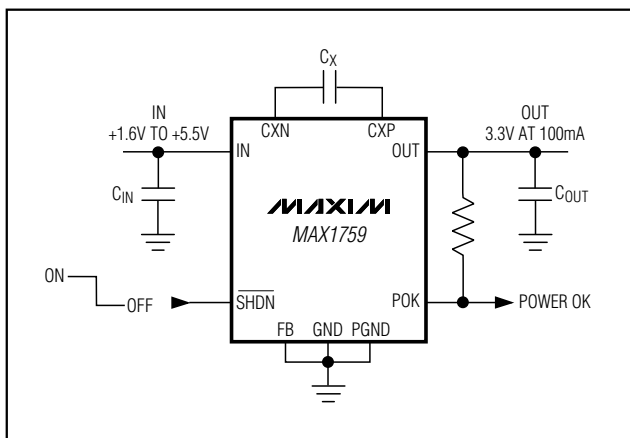

Dual Mode is a trademark of Maxim Integrated Products.

Features

- ◆ Regulated Output Voltage (Fixed 3.3V or Adjustable 2.5V to 5.5V)
- ◆ 100mA Guaranteed Output Current
- ◆ +1.6V to +5.5V Input Voltage Range
- ◆ Low 50 μ A Quiescent Supply Current
- ◆ 1 μ A Shutdown Mode
- ◆ Load Disconnected from Input in Shutdown
- ◆ High 1.5MHz Operating Frequency
- ◆ Uses Small Ceramic Capacitors
- ◆ Short-Circuit Protection and Thermal Shutdown
- ◆ Small 10-Pin μ MAX Package

Ordering Information

PART	TEMP. RANGE	PIN-PACKAGE
MAX1759EUB	-40°C to +85°C	10 μ MAX

Pin Configuration

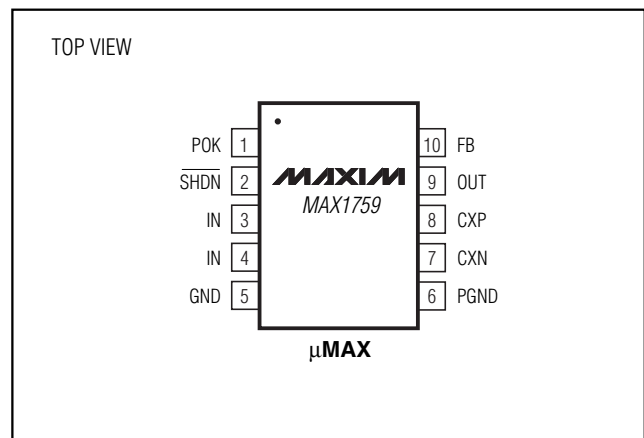

Buck/Boost Regulating Charge Pump in μ MAX

ABSOLUTE MAXIMUM RATINGS

IN, OUT, FB, POK, $\overline{\text{SHDN}}$ to GND -0.3V to +6V
 PGND to GND ± 0.3 V
 CXN to GND -0.3V to ($V_{\text{IN}} + 0.3$)V
 CXP to GND -0.3V to ($V_{\text{OUT}} + 0.3$)V
 OUT Short to GND Indefinite
 Continuous Power Dissipation ($T_A = +70^\circ\text{C}$)
 10-Pin μ MAX (derate 5.6mW/ $^\circ\text{C}$ above $+70^\circ\text{C}$) 444mW

Operating Temperature Range -40°C to $+85^\circ\text{C}$
 Junction Temperature $+150^\circ\text{C}$
 Storage Temperature Range -65°C to $+150^\circ\text{C}$
 Lead Temperature (soldering, 10s) $+300^\circ\text{C}$

Stresses beyond those listed under "Absolute Maximum Ratings" may cause permanent damage to the device. These are stress ratings only, and functional operation of the device at these or any other conditions beyond those indicated in the operational sections of the specifications is not implied. Exposure to absolute maximum rating conditions for extended periods may affect device reliability.

ELECTRICAL CHARACTERISTICS

(Circuit of Figure 1, $V_{\text{IN}} = V_{\overline{\text{SHDN}}} = 2\text{V}$, FB = PGND = GND, $C_{\text{IN}} = 10\mu\text{F}$, $C_X = 0.33\mu\text{F}$, $C_{\text{OUT}} = 10\mu\text{F}$, $T_A = 0^\circ\text{C}$ to $+85^\circ\text{C}$, unless otherwise noted. Typical values are at $T_A = +25^\circ\text{C}$.)

PARAMETER	SYMBOL	CONDITIONS	MIN	TYP	MAX	UNITS
Input Voltage Range	V_{IN}		1.6		5.5	V
Input Undervoltage Lockout Voltage	V_{UVLO}		0.6	1.0	1.4	V
Output Voltage Adjustment Range		$1.6\text{V} \leq V_{\text{IN}} \leq 5.5\text{V}$	2.5		5.5	V
Output Voltage	V_{OUT}	$2\text{V} \leq V_{\text{IN}} \leq 5.5\text{V}$, $1\text{mA} \leq I_{\text{LOAD}} \leq 50\text{mA}$	3.17	3.3	3.43	V
		$2.5\text{V} \leq V_{\text{IN}} \leq 5.5\text{V}$, $1\text{mA} \leq I_{\text{LOAD}} \leq 100\text{mA}$	3.17	3.3	3.43	
Maximum Output Current	$I_{\text{LOAD,MAX}}$	$2.5\text{V} \leq V_{\text{IN}} \leq 5.5\text{V}$	100			mA
Transient Load Current		$I_{\text{LOAD}} \leq 100\text{mA}$ (RMS)		200		mA
Quiescent Supply Current	I_{Q}	$V_{\text{IN}} = V_{\overline{\text{SHDN}}} = 4\text{V}$, $V_{\text{FB}} = 0$, stepping down		50	90	μA
		$V_{\text{IN}} = V_{\overline{\text{SHDN}}} = 2\text{V}$, $V_{\text{FB}} = 0$, stepping up		85	180	
Shutdown Supply Current	$I_{\text{Q,SHDN}}$	$1.6\text{V} \leq V_{\text{IN}} \leq 5.5\text{V}$, $V_{\overline{\text{SHDN}}} = 0$		1	5	μA
Leakage Current into OUT in Shutdown		$V_{\text{IN}} = 2\text{V}$, $V_{\text{OUT}} = 3.3\text{V}$, $V_{\overline{\text{SHDN}}} = 0$		1	5	μA
$\overline{\text{SHDN}}$ Logic Input Voltage	V_{IL}	$1.6\text{V} \leq V_{\text{IN}} \leq 5.5\text{V}$		$0.25 \cdot V_{\text{IN}}$		V
	V_{IH}	$1.6\text{V} \leq V_{\text{IN}} \leq 5.5\text{V}$	$0.7 \cdot V_{\text{IN}}$			
$\overline{\text{SHDN}}$ Input Leakage Current	$I_{\overline{\text{SHDN}}}$	$V_{\overline{\text{SHDN}}} = 5.5\text{V}$	-1		1	μA
FB Regulation Voltage	V_{FB}	$V_{\text{IN}} = 1.65\text{V}$, $V_{\text{OUT}} = 3.3\text{V}$	1.205	1.235	1.265	V
FB Input Current		$V_{\text{FB}} = 1.27\text{V}$		25	200	nA
FB Dual-Mode Threshold		Internal feedback		100	50	mV
		External feedback	200	100		mV
POK Trip Voltage		Falling edge at FB	1.0	1.1	1.2	V
POK Output Low Voltage	V_{OL}	$I_{\text{SINK}} = 0.5\text{mA}$, $V_{\text{IN}} = 2\text{V}$		5	100	mV
POK Leakage Current		$V_{\text{POK}} = 5.5\text{V}$, $V_{\text{FB}} = 1.27\text{V}$		0.01	0.2	μA
Switching Frequency	f_{OSC}	$1.6\text{V} \leq V_{\text{IN}} \leq 5.5\text{V}$, $V_{\text{FB}} = 1\text{V}$	1.2	1.5	1.8	MHz
Output Short-Circuit Current		$V_{\text{OUT}} = 0$, $2.5\text{V} \leq V_{\text{IN}} \leq 5.5\text{V}$, foldback current limit		110		mA
Thermal Shutdown Temperature		Rising temperature		160		$^\circ\text{C}$
Thermal Shutdown Hysteresis				20		$^\circ\text{C}$
Efficiency		$V_{\text{IN}} = 3.6\text{V}$, $I_{\text{LOAD}} = 10\text{mA}$		90		%

Buck/Boost Regulating Charge Pump in μ MAX

MAX1759

ELECTRICAL CHARACTERISTICS

(Circuit of Figure 1, $V_{IN} = V_{\overline{SHDN}} = 2V$, $FB = PGND = GND$, $C_{IN} = 10\mu F$, $C_X = 0.33\mu F$, $C_{OUT} = 10\mu F$, $T_A = -40^\circ C$ to $+85^\circ C$, unless otherwise noted.) (Note 1)

PARAMETER	SYMBOL	CONDITIONS	MIN	MAX	UNITS
Input Voltage Range	V_{IN}		1.6	5.5	V
Input Undervoltage Lockout Voltage	V_{UVLO}		0.6	1.4	V
Output Voltage	V_{OUT}	$2V \leq V_{IN} \leq 5.5V$, $0 \leq I_{LOAD} \leq 50mA$	3.15	3.45	V
		$2.5V \leq V_{IN} \leq 5.5V$, $0 \leq I_{LOAD} \leq 100mA$	3.15	3.45	V
Output Voltage Adjustment Range		$1.6V \leq V_{IN} \leq 5.5V$	2.5	5.5	V
Maximum Output Current	$I_{LOAD,MAX}$	$2.5V \leq V_{IN} \leq 5.5V$	100		mA
Quiescent Supply Current	I_Q	$V_{IN} = V_{\overline{SHDN}} = 4V$, $V_{FB} = 0$		90	μA
		$V_{IN} = V_{\overline{SHDN}} = 2.5V$, $V_{FB} = 0$		180	μA
Shutdown Supply Current	$I_{Q,SHDN}$	$1.6V \leq V_{IN} \leq 5.5V$, $V_{\overline{SHDN}} = 0$		6	μA
Leakage Current into OUT in Shutdown		$V_{IN} = 2V$, $V_{OUT} = 3.3V$, $V_{\overline{SHDN}} = 0$		5	μA
\overline{SHDN} Input Logic Voltage	V_{IL}	$1.6V \leq V_{IN} \leq 5.5V$		$0.2 \cdot V_{IN}$	V
	V_{IH}	$1.6V \leq V_{IN} \leq 5.5V$	$0.7 \cdot V_{IN}$		V
\overline{SHDN} Input Leakage Current	$I_{\overline{SHDN}}$	$V_{\overline{SHDN}} = 5.5V$	-1	1	μA
FB Regulation Voltage	V_{FB}	$V_{IN} = 1.65V$, $V_{OUT} = 3.3V$	1.205	1.265	V
FB Input Bias Current		$V_{FB} = 1.27V$		200	nA
FB Dual Mode Threshold		Internal feedback		40	mV
		External feedback	200		mV
POK Trip Voltage		Falling edge at FB	1.0	1.2	V
POK Output Low Voltage	V_{OL}	$I_{SINK} = 0.5mA$, $V_{IN} = 2V$		100	mV
POK Leakage Current		$V_{POK} = 5.5V$		0.2	μA
Switching Frequency	f_{OSC}	$1.6V \leq V_{IN} \leq 5.5V$, $V_{FB} = 1V$	1.1	1.9	MHz

Note 1: Specifications to $-40^\circ C$ are guaranteed by design and are not production tested.

Buck/Boost Regulating Charge Pump in μ MAX

Typical Operating Characteristics

(Circuit of Figure 1, $C_{IN} = 10\mu F$, $C_X = 0.33\mu F$, $C_{OUT} = 10\mu F$, $V_{OUT} = 3.3V$, $V_{IN} = 2.5V$, $T_A = +25^\circ C$, unless otherwise noted.)

OUTPUT VOLTAGE RIPPLE vs. INPUT VOLTAGE

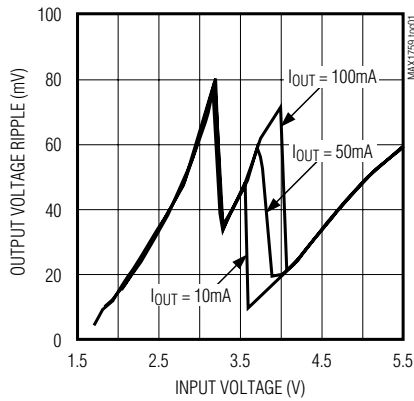

OUTPUT VOLTAGE vs. LOAD CURRENT

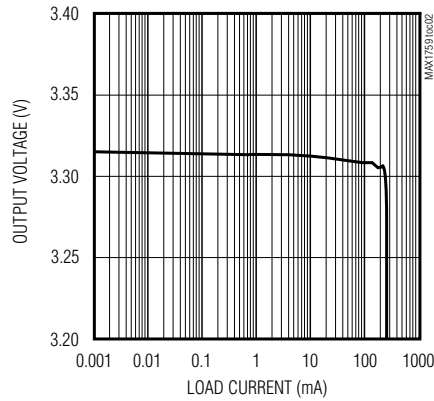

EFFICIENCY vs. INPUT VOLTAGE

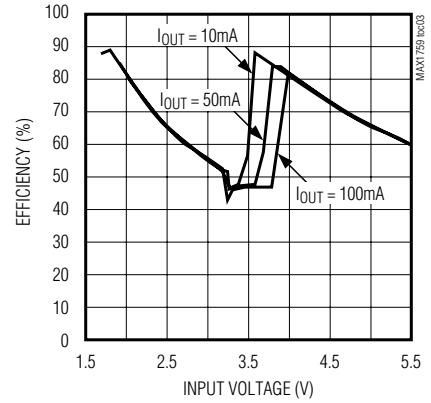

QUIESCENT CURRENT vs. INPUT VOLTAGE

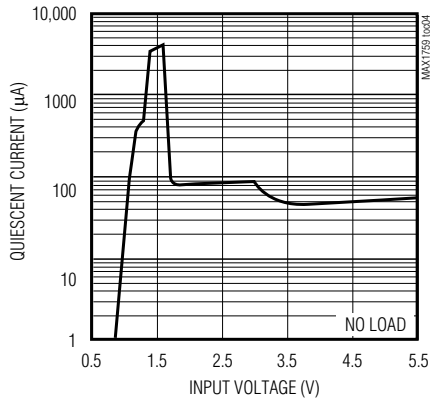

STARTUP INPUT VOLTAGE (VOUT < VIN)

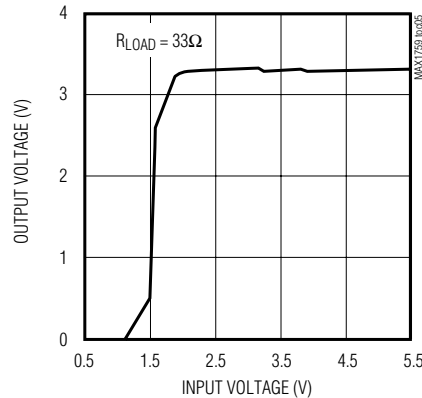

TYPICAL SWITCHING WAVEFORMS (VOUT < VIN)

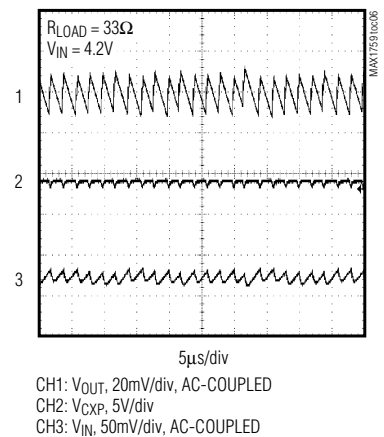

TYPICAL SWITCHING WAVEFORMS (VOUT > VIN)

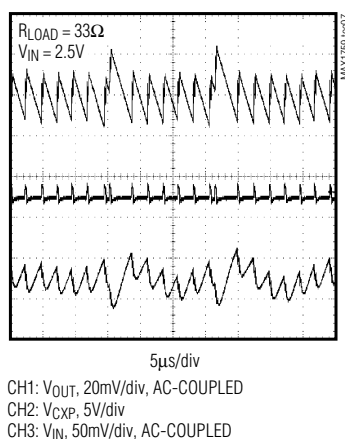

LOAD-TRANSIENT RESPONSE (VOUT < VIN)

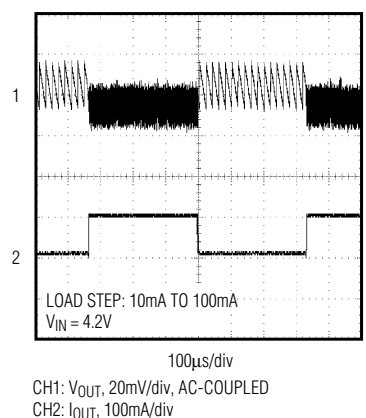

LOAD-TRANSIENT RESPONSE (VOUT > VIN)

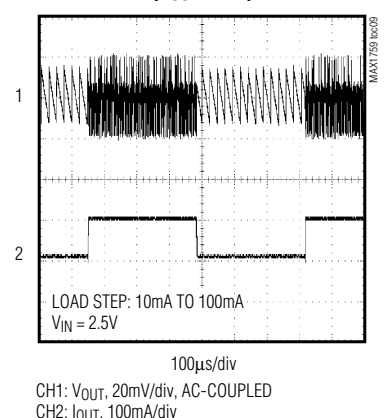

CH1: V_{OUT} , 20mV/div, AC-COUPLED
CH2: V_{CXP} , 5V/div
CH3: V_{IN} , 50mV/div, AC-COUPLED

CH1: V_{OUT} , 20mV/div, AC-COUPLED
CH2: I_{OUT} , 100mA/div

CH1: V_{OUT} , 20mV/div, AC-COUPLED
CH2: I_{OUT} , 100mA/div

Buck/Boost Regulating Charge Pump in μ MAX

MAX1759

Typical Operating Characteristics (continued)

(Circuit of Figure 1, $C_{IN} = 10\mu\text{F}$, $C_X = 0.33\mu\text{F}$, $C_{OUT} = 10\mu\text{F}$, $V_{OUT} = 3.3\text{V}$, $V_{IN} = 2.5\text{V}$, $T_A = +25^\circ\text{C}$, unless otherwise noted.)

LINE-TRANSIENT RESPONSE

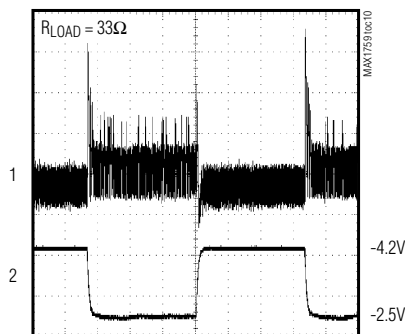

CH1: V_{OUT} , 20mV/div, AC-COUPLED
CH2: V_{IN} , 1V/div, AC-COUPLED

**TURN-ON/OFF RESPONSE
($V_{IN} = 4.2\text{V}$)**

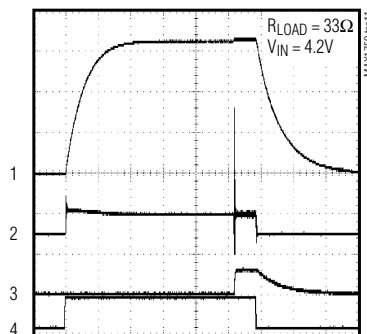

CH1: V_{OUT} , 1V/div
CH2: I_{IN} , 200mA/div
CH3: V_{POK} , 5V/div
CH4: V_{SHDN} , 5V/div

**TURN-ON/OFF RESPONSE
($V_{IN} = 2.5\text{V}$)**

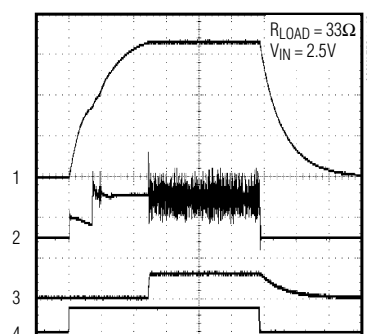

CH1: V_{OUT} , 1V/div
CH2: I_{IN} , 200mA/div
CH3: V_{POK} , 5V/div
CH4: V_{SHDN} , 5V/div

Pin Description

PIN	NAME	FUNCTION
1	POK	Open-Drain Power-OK Output. POK is high impedance when output voltage is in regulation. POK sinks current when V_{FB} falls below 1.1V. Connect a 10k Ω to 1M Ω pull-up resistor from POK to V_{OUT} for a logic signal. Ground POK or leave unconnected if not used. POK is high impedance in shutdown.
2	$\overline{\text{SHDN}}$	Shutdown Input. Drive high for normal operation; drive low for shutdown mode. OUT is high impedance in shutdown.
3, 4	IN	Input Supply. Connect both pins together and bypass to GND with a ceramic capacitor (see <i>Capacitor Selection</i> section).
5	GND	Ground. Connect GND to PGND with a short trace.
6	PGND	Power Ground. Charge-pump current flows through this pin.
7	CXN	Negative Terminal of the Charge-Pump Transfer Capacitor
8	CXP	Positive Terminal of the Charge-Pump Transfer Capacitor
9	OUT	Power Output. Bypass to GND with an output filter capacitor.
10	FB	Dual-Mode Feedback. Connect FB to GND for 3.3V output. Connect to an external resistor divider to adjust the output voltage from 2.5V to 5.5V.

Buck/Boost Regulating Charge Pump in μ MAX

Detailed Description

The MAX1759's unique charge-pump architecture allows the input voltage to be higher or lower than the regulated output voltage. Internal circuitry senses V_{IN} and V_{OUT} and determines whether V_{IN} must be stepped up or stepped down to produce the regulated output. When V_{IN} is lower than V_{OUT} , the charge pump operates as a regulated step-up voltage doubler. When V_{IN} is higher than V_{OUT} , the charge pump operates as a step-down gated switch.

In voltage step-down mode (i.e., the input voltage is greater than the output voltage) with a light load, the controller connects CXN to PGND, and shuttles charge to the output by alternately connecting CXP from IN to OUT (see Figures 1 and 2). Although V_{IN} is greater than V_{OUT} , this scheme may not allow the MAX1759 to regulate the output under heavy loads. In this case, the MAX1759 will automatically switch to step-up mode. In step-up mode, the output is kept in regulation by modulating the charge delivered by the transfer capacitor (C_x) to the load (see Figure 2). When lightly loaded, the charge pump switches only as necessary to supply the load, resulting in low quiescent current. Output voltage ripple does not increase with light loads.

Shutdown Mode

Driving $\overline{\text{SHDN}}$ low places the MAX1759 in shutdown mode. This disables the charge-pump switches, oscillator, and control logic, reducing quiescent current to $1\mu\text{A}$. The output is high impedance in shutdown and is disconnected from the input. The POK output is high impedance in shutdown.

Undervoltage Lockout

The MAX1759 undervoltage lockout feature deactivates the device when the input voltage falls below 1V.

Power-OK Output

POK is an open-drain output that sinks current when the regulator feedback voltage falls below 1.1V. The feedback voltage can be either the internal resistor-divider feedback voltage when in fixed output mode (FB tied to GND) or an external feedback voltage from an external resistive divider in adjustable output mode. A $10\text{k}\Omega$ to $1\text{M}\Omega$ pull-up resistor from POK to OUT may be used to provide a logic output. Connect POK to GND or leave unconnected if not used.

Soft-Start and Short-Circuit Protection

The MAX1759 features foldback short-circuit protection. This circuitry provides soft-start by limiting inrush current during startup and limits the output current to 110mA (typ) if the output is short-circuited to ground.

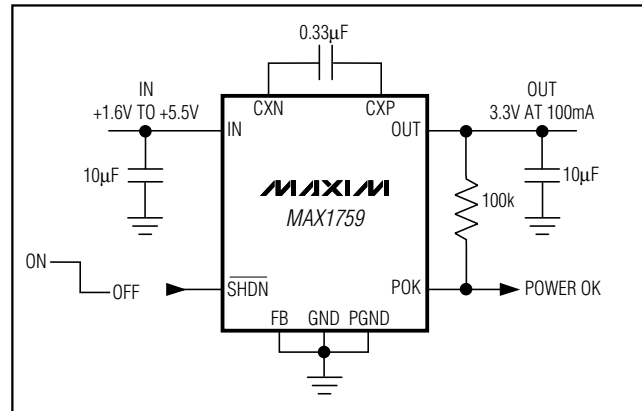

Figure 1. Typical Application Circuit

Thermal Shutdown

The MAX1759 features thermal shutdown with temperature hysteresis. When the die temperature exceeds 160°C , the device shuts down. When the die cools by 20°C , the MAX1759 turns on again. If high die temperature is caused by output overload and the load is not removed, the device will turn off and on, resulting in a pulsed output.

Design Procedure

Setting the Output Voltage

The MAX1759 dual-mode feedback controller selects between the internally set 3.3V regulated output or an external resistive divider that allows adjustment of the output voltage from 2.5V to 5.5V. Connect FB to GND for a regulated 3.3V output. For an adjustable output, connect a resistive divider between OUT and GND. To ensure feedback-loop stability and to minimize error due to FB pin bias currents, the resistive divider current should be approximately $15\mu\text{A}$. In the following equation, choose R_2 in the $50\text{k}\Omega$ to $100\text{k}\Omega$ range, and calculate R_1 from the following formula (Figure 3):

$$R_1 = R_2 [(V_{OUT} / V_{FB}) - 1]$$

and

$$V_{OUT} = V_{FB} (R_1 + R_2) / R_2$$

where V_{OUT} is the desired output voltage from 2.5V to 5.5V, and V_{FB} is the internal regulation voltage, nominally 1.235V.

The circuit of Figure 3 generates a regulated 2.5V, using external standard 1% resistor values. Surface-mount resistors should be placed close to the MAX1759, less than 5mm away from FB (see the *PC Board Layout* section).

Buck/Boost Regulating Charge Pump in μ MAX

MAX1759

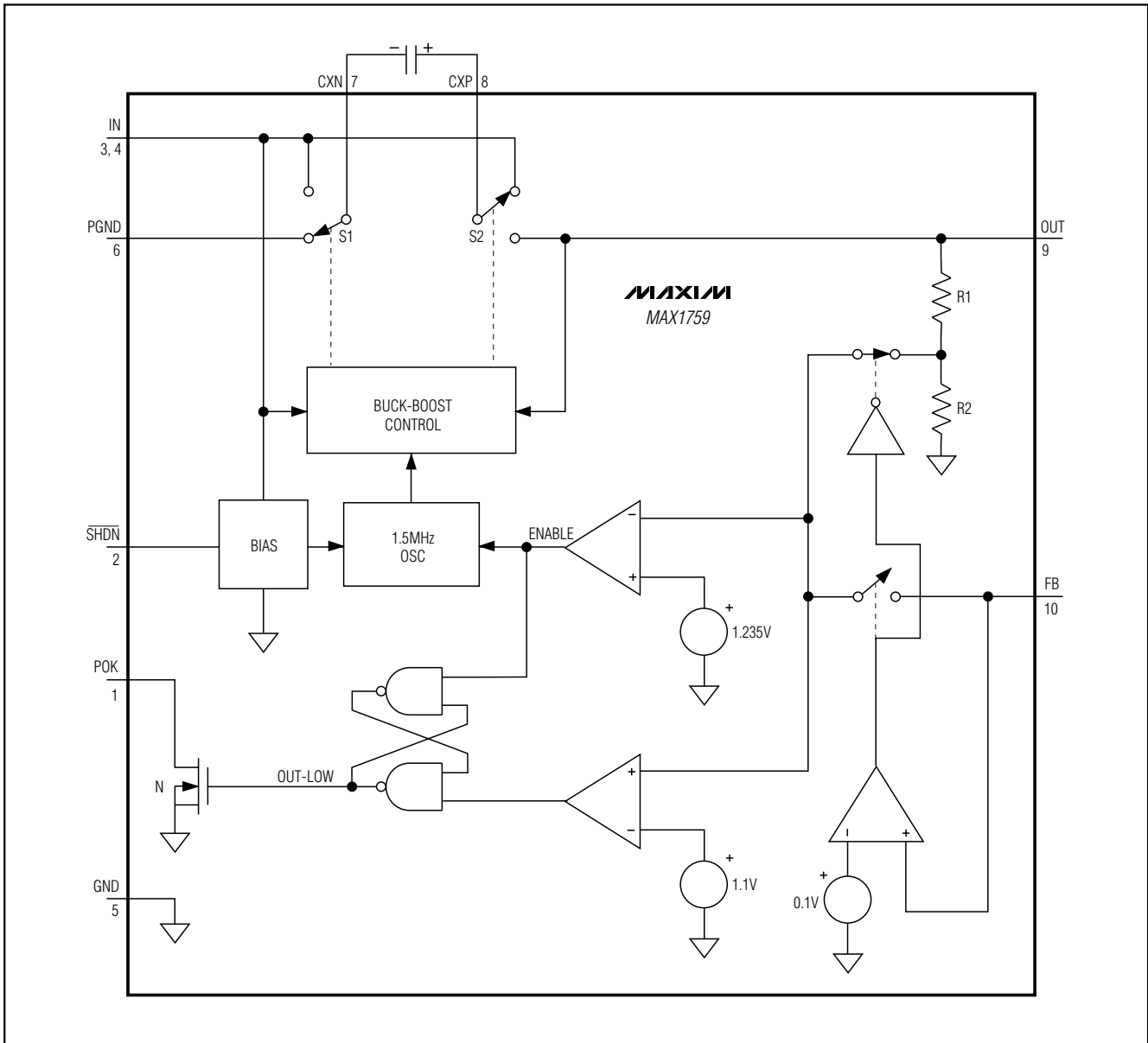

Figure 2. Functional Diagram

Buck/Boost Regulating Charge Pump in μ MAX

Capacitor Selection

Optimize the charge-pump circuit for physical size, output current, and output ripple by selecting capacitors C_{IN} , C_X , and C_{OUT} . See Table 1 for suggested capacitor values.

Note that capacitors must have low ESR ($\leq 20\text{m}\Omega$) to maintain low output ripple. Ceramic capacitors are recommended. In cost-sensitive applications where high output current is needed, the output capacitor may be a combination of a $1\mu\text{F}$ ceramic in parallel with a $10\mu\text{F}$ tantalum capacitor. The ceramic capacitor's low ESR will help keep output ripple within acceptable levels.

Output Voltage Ripple

The MAX1759 proprietary control scheme automatically chooses between voltage doubling and voltage step-down to maintain output voltage regulation over various load currents and V_{IN} to V_{OUT} voltage differentials.

When V_{IN} is lower than V_{OUT} , the charge pump always operates in voltage-doubler mode. It regulates the output voltage by modulating the charge delivered by the transfer capacitor.

When V_{IN} is higher than V_{OUT} , the charge pump operates in voltage step-down mode, but may revert to voltage-doubler mode if necessary to maintain regulation under load. While operating in step-down mode, the output voltage ripple is typically much lower than it is in voltage-doubler mode (see *Typical Operating Characteristics*).

Output Current

The MAX1759 is guaranteed to deliver a regulated 3.3V at 100mA continuous, from a +2.5V input. Peaks up to 200mA are acceptable as long as the current is $\leq 100\text{mA}$ (RMS).

Applications Information

PC Board Layout

The MAX1759 is a high-frequency switched-capacitor voltage regulator. For best circuit performance, use a ground plane and keep C_{IN} , C_X , C_{OUT} , and feedback resistors (if used) close to the device. If using external feedback, keep the feedback node as small as possible by positioning the feedback resistors very close to FB. Suggested PC component placement and board layout are shown in Figures 4a and 4b.

Chip Information

TRANSISTOR COUNT: 1802

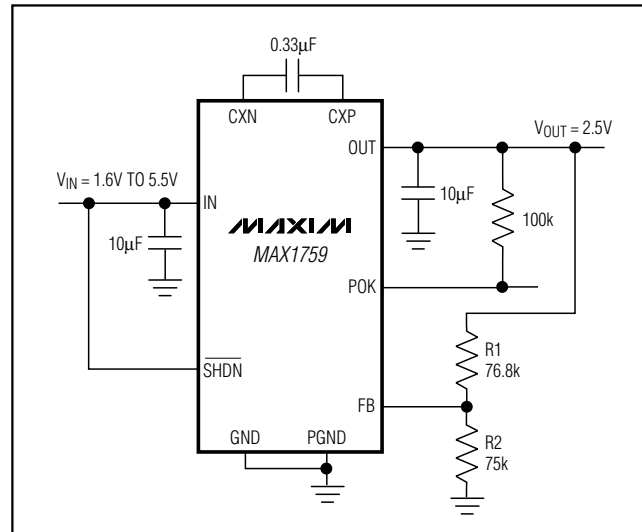

Figure 3. Using External Feedback for Regulated 2.5V Output

Table 1. Capacitor Selection

OUTPUT CURRENT (mA)	CAPACITOR VALUE			OUTPUT RIPPLE (mV)	
	C_{IN} (μF)	C_X (μF)	C_{OUT} (μF)	$V_{IN} = 2.5\text{V}$	$V_{IN} = 4.2\text{V}$
100	10	0.33	10	40	20
100	4.7	0.22	4.7	80	60
50	2.2	0.1	2.2	100	80

Buck/Boost Regulating Charge Pump in μ MAX

MAX1759

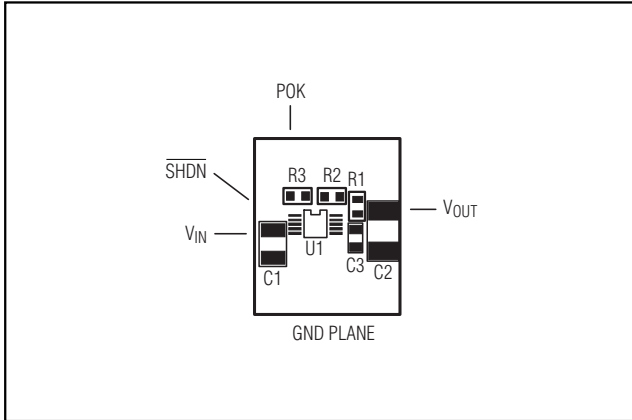

Figure 4a. MAX1759 Component Placement Guide

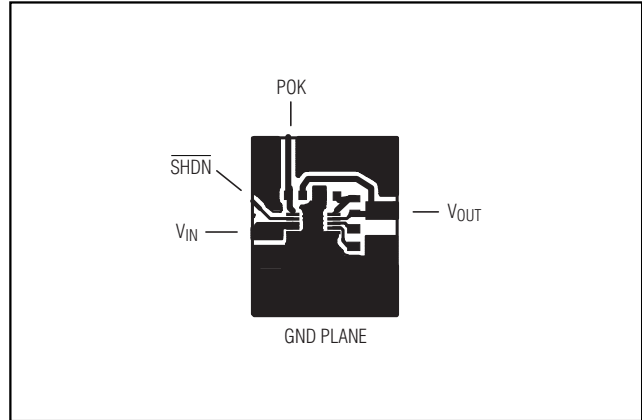
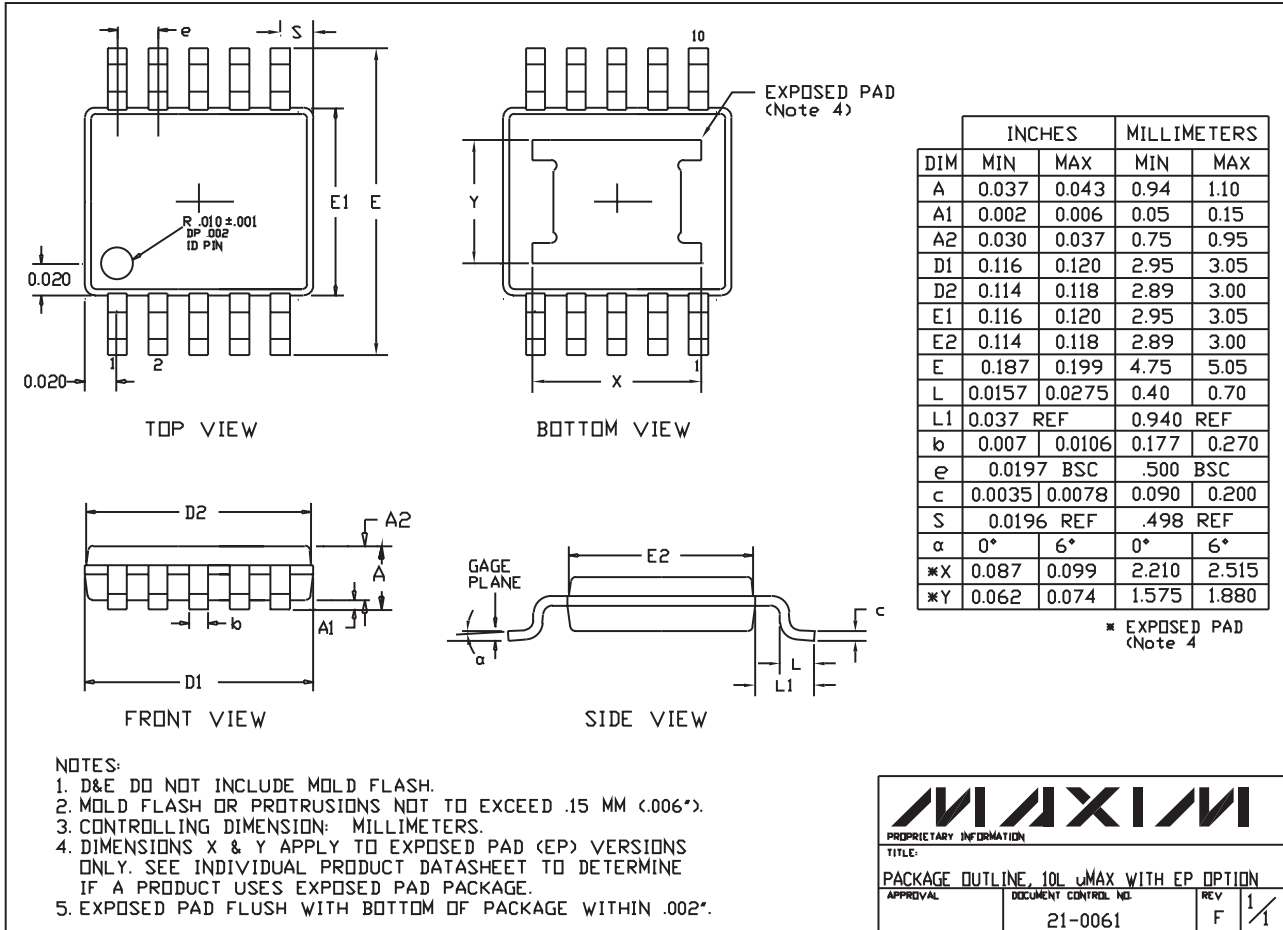

Figure 4b. MAX1759 Recommended PC Board Layout

Buck/Boost Regulating Charge Pump in μ MAX

Package Information



Note: The MAX1759 does not have an exposed pad.

Buck/Boost Regulating Charge Pump in μ MAX

NOTES

MAX1759

Buck/Boost Regulating Charge Pump in μ MAX

NOTES

Maxim cannot assume responsibility for use of any circuitry other than circuitry entirely embodied in a Maxim product. No circuit patent licenses are implied. Maxim reserves the right to change the circuitry and specifications without notice at any time.

12 _____ **Maxim Integrated Products, 120 San Gabriel Drive, Sunnyvale, CA 94086 408-737-7600**