



+145°C Precision SMBus-Compatible Remote/Local Sensors with Overtemperature Alarms

General Description

The MAX6646/MAX6647/MAX6649 are precise, two-channel digital temperature sensors. The devices accurately measure the temperature of their own die and a remote PN junction, and report the temperature in digital form using a 2-wire serial interface. The remote PN junction is typically the emitter-base junction of a common-collector PNP on a CPU, FPGA, or ASIC.

The 2-wire serial interface accepts standard system management bus (SMBus) write byte, read byte, send byte, and receive byte commands to read the temperature data and to program the alarm thresholds. To enhance system reliability, the MAX6646/MAX6647/MAX6649 include an SMBus timeout. A fault queue prevents the $\overline{\text{ALERT}}$ and $\overline{\text{OVERT}}$ outputs from setting until a fault has been detected one, two, or three consecutive times (programmable).

The MAX6646/MAX6647/MAX6649 provide two system alarms: $\overline{\text{ALERT}}$ and $\overline{\text{OVERT}}$. $\overline{\text{ALERT}}$ asserts when any of four temperature conditions are violated: local overtemperature, remote overtemperature, local undertemperature, or remote undertemperature. $\overline{\text{OVERT}}$ asserts when the temperature rises above the value in either of the two $\overline{\text{OVERT}}$ limit registers. The $\overline{\text{OVERT}}$ output can be used to activate a cooling fan, or to trigger a system shutdown.

Measurements can be done autonomously, at the programmed conversion rate, or in a single-shot mode. The adjustable conversion rate allows optimizing supply current and temperature update rate to match system needs.

Remote accuracy is $\pm 1^\circ\text{C}$ maximum error between $+60^\circ\text{C}$ and $+145^\circ\text{C}$ with no calibration needed. The MAX6646/MAX6647/MAX6649 operate from -55°C to $+125^\circ\text{C}$, and measure temperatures between 0°C and $+145^\circ\text{C}$. The MAX6646/MAX6647/MAX6649 are available in an 8-pin μMAX° package.

Applications

Graphics Processors	Thin Clients
Desktop Computers	Workstations
Notebook Computers	Test and Measurement
Servers	Multichip Modules

Selector Guide, Pin Configurations, and Functional Diagram appear at end of data sheet.

μMAX is a registered trademark of Maxim Integrated Products, Inc.

Features

- ◆ **Dual Channel: Measures Remote and Local Temperature**
- ◆ **0.125°C Resolution**
- ◆ **High Accuracy $\pm 1^\circ\text{C}$ (max) from $+60^\circ\text{C}$ to $+145^\circ\text{C}$ (Remote), and $\pm 2^\circ\text{C}$ (max) from $+60^\circ\text{C}$ to $+100^\circ\text{C}$ (Local)**
- ◆ **Measures High-Ideality Thermal Diodes Up to $+170^\circ\text{C}$ (Apparent) $+145^\circ\text{C}$ (Real)**
- ◆ **Two Alarm Outputs: $\overline{\text{ALERT}}$ and $\overline{\text{OVERT}}$**
- ◆ **Programmable Under/Overtemperature Alarm Temperature Thresholds**
- ◆ **Programmable Conversion Rate**
- ◆ **SMBus-Compatible Interface**
- ◆ **SMBus Timeout**

Ordering Information

PART	TEMP RANGE	PIN-PACKAGE	MEASURED TEMP RANGE
MAX6646MUA+	-55°C to $+125^\circ\text{C}$	8 μMAX	0°C to $+145^\circ\text{C}$
MAX6647MUA+	-55°C to $+125^\circ\text{C}$	8 μMAX	0°C to $+145^\circ\text{C}$
MAX6649MUA+	-55°C to $+125^\circ\text{C}$	8 μMAX	0°C to $+145^\circ\text{C}$

+Denotes a lead(Pb)-free/RoHS-compliant package.

Typical Operating Circuit

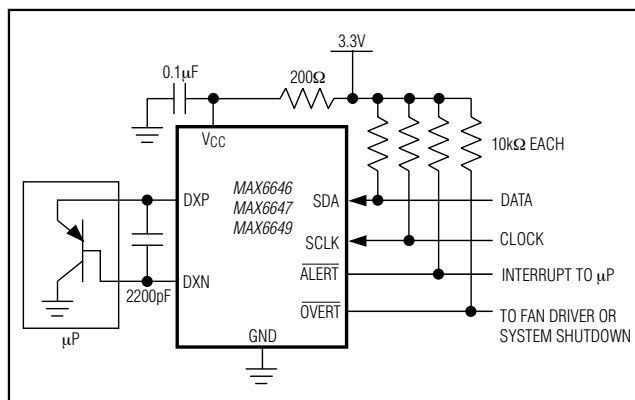

For pricing, delivery, and ordering information, please contact Maxim Direct at 1-888-629-4642, or visit Maxim's website at www.maxim-ic.com.

+145°C Precision SMBus-Compatible Remote/Local Sensors with Overtemperature Alarms

ABSOLUTE MAXIMUM RATINGS

All Voltages Referenced to GND

V _{CC}	-0.3V to +6V
DXP.....	-0.3V to (V _{CC} + 0.3V)
DXN.....	-0.3V to +0.8V
SCLK, SDA, ALERT, OVERT.....	-0.3V to +6V
SDA, ALERT, OVERT Current.....	-1mA to +50mA
DXN Current.....	±1mA
Continuous Power Dissipation (T _A = +70°C) μMAX (derate 4.8mW/°C above +70°C).....	387.8mW

ESD Protection (all pins, Human Body Model).....	±2000V
Junction Temperature.....	+150°C
Operating Temperature Range.....	-55°C to +125°C
Storage Temperature Range.....	-65°C to +150°C
Soldering Temperature (reflow).....	+260°C
Lead Temperature (soldering, 10s).....	+300°C

Stresses beyond those listed under "Absolute Maximum Ratings" may cause permanent damage to the device. These are stress ratings only, and functional operation of the device at these or any other conditions beyond those indicated in the operational sections of the specifications is not implied. Exposure to absolute maximum rating conditions for extended periods may affect device reliability.

ELECTRICAL CHARACTERISTICS

(V_{CC} = 3.0V to 5.5V, T_A = -55°C to +125°C, unless otherwise specified. Typical values are at V_{CC} = 3.3V and T_A = +100°C.) (Note 1)

PARAMETER	SYMBOL	CONDITIONS	MIN	TYP	MAX	UNITS	
Supply Voltage	V _{CC}		3.0		5.5	V	
Temperature Resolution			0.125			°C	
				11		Bits	
Remote Temperature Error		V _{CC} = 3.3V, T _A = +100°C, T _{RJ} = +60°C to +145°C	-1.0		+1.0	°C	
		V _{CC} = 3.3V, T _A = +60°C to +100°C, T _{RJ} = +25°C to +145°C	-1.6		+1.6		
		V _{CC} = 3.3V, T _A = +0°C to +100°C, T _{RJ} = +0°C to +145°C	-3.2		+3.2		
Local Temperature Error		V _{CC} = 3.3V	T _A = +60°C to +100°C	-2.0		+2.0	°C
			T _A = 0°C to +125°C	-3.0		+3.0	
Supply Sensitivity of Temperature Error				±0.2		°C/V	
Undervoltage Lockout (UVLO) Threshold	UVLO	Falling edge of V _{CC} disables ADC	2.4	2.7	2.95	V	
UVLO Hysteresis				90		mV	
Power-On-Reset (POR) Threshold		V _{CC} falling edge		2.0		V	
POR Threshold Hysteresis				90		mV	
Standby Supply Current		SMBus static		3	12	μA	
Operating Current		During conversion			0.08	mA	
Average Operating Current		0.25 conversions per second		40	80	μA	
		2 conversions per second		250	400		
Conversion Time	t _{CONV}	From stop bit to conversion completion	95	125	156	ms	
Conversion Time Error			-25		+25	%	
DXP and DXN Leakage Current		Standby mode			100	nA	
Remote-Diode Source Current	I _{RJ}	High level	80	100	120	μA	
		Low level	8	10	12		

+145°C Precision SMBus-Compatible Remote/ Local Sensors with Overtemperature Alarms

MAX6646/MAX6647/MAX6649

ELECTRICAL CHARACTERISTICS (continued)

(V_{CC} = 3.0V to 5.5V, T_A = -55°C to +125°C, unless otherwise specified. Typical values are at V_{CC} = 3.3V and T_A = +100°C.) (Note 1)

PARAMETER	SYMBOL	CONDITIONS	MIN	TYP	MAX	UNITS
ALERT, OVERT						
Output Low Voltage		I _{SINK} = 1mA			0.4	V
		I _{SINK} = 4mA			0.6	
Output High Leakage Current		V _{OH} = 5.5V			1	μA
SMBus-COMPATIBLE INTERFACE (SCLK AND SDA)						
Logic Input Low Voltage	V _{IL}				0.8	V
Logic Input High Voltage	V _{IH}	V _{CC} = 3.0V	2.2			V
		V _{CC} = 5.5V	2.6			
Input Leakage Current	I _{LEAK}	V _{IN} = V _{GND} or V _{CC}	-1		+1	μA
Output Low-Sink Current	I _{SINK}	V _{OL} = 0.6V	6			mA
Input Capacitance	C _{IN}			5		pF
SMBus-COMPATIBLE TIMING (Note 2)						
Serial Clock Frequency	f _{SCLK}	(Note 3)			100	kHz
Bus Free Time Between STOP and START Condition	t _{BUF}		4.7			μs
Repeat START Condition Setup Time	t _{SU:STA}		4.7			μs
START Condition Hold Time	t _{HD:STA}	10% of SDA to 90% of SCLK	4			μs
STOP Condition Setup Time	t _{SU:STO}	90% of SCLK to 90% of SDA	4			μs
Clock Low Period	t _{LOW}	10% to 10%	4.7			μs
Clock High Period	t _{HIGH}	90% to 90%	4			μs
Data Setup Time	t _{SU:DAT}		250			ns
Data Hold Time	t _{HD:DAT}	(Note 4)	250			ns
Receive SCLK/SDA Rise Time	t _R				1	μs
Receive SCLK/SDA Fall Time	t _F				300	ns
Pulse Width of Spike Suppressed	t _{SP}		0		50	ns
SMBus Timeout	t _{TIMEOUT}	SDA low period for interface reset	25	37	55	ms

Note 1: All parameters tested at a single temperature. Specifications over temperature are guaranteed by design.

Note 2: Timing specifications guaranteed by design.

Note 3: The serial interface resets when SCLK is low for more than t_{TIMEOUT}.

Note 4: A transition must internally provide at least a hold time to bridge the undefined region (300ns max) of SCLK's falling edge.

+145°C Precision SMBus-Compatible Remote/Local Sensors with Overtemperature Alarms

Typical Operating Characteristics

($V_{CC} = 3.3V$, $T_A = +25^\circ C$, unless otherwise noted.)

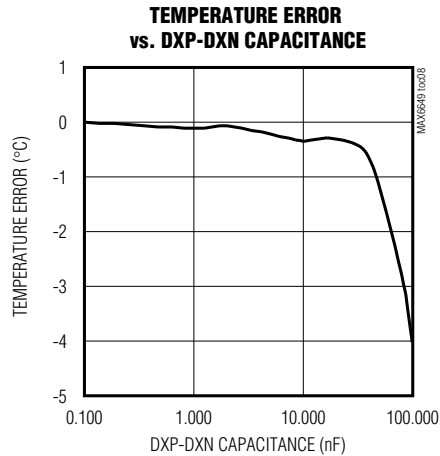
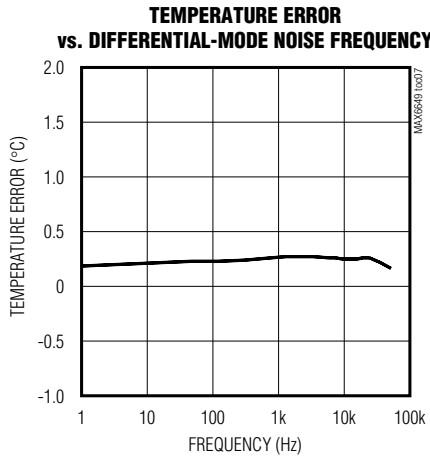
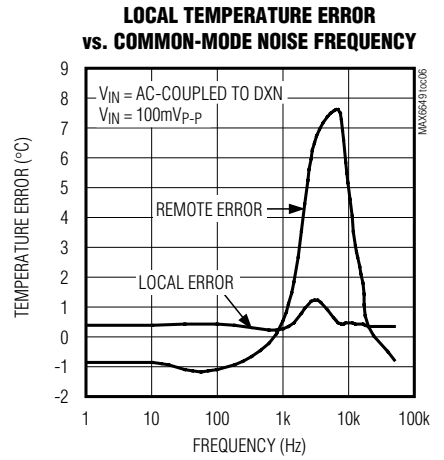
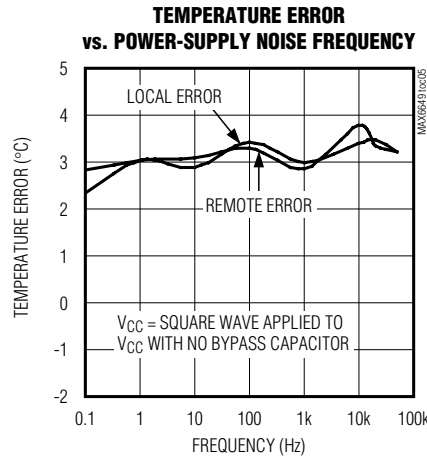
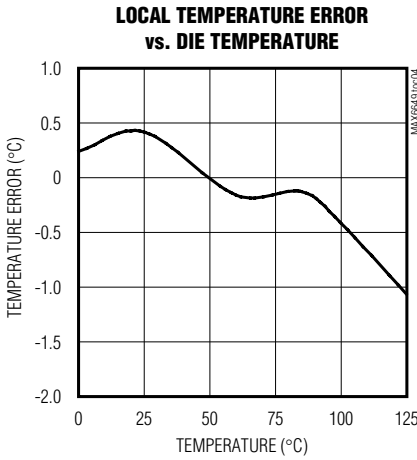
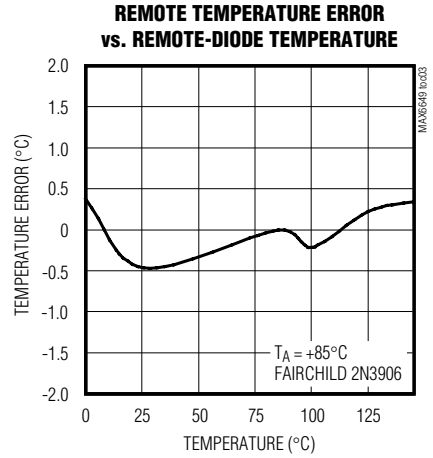
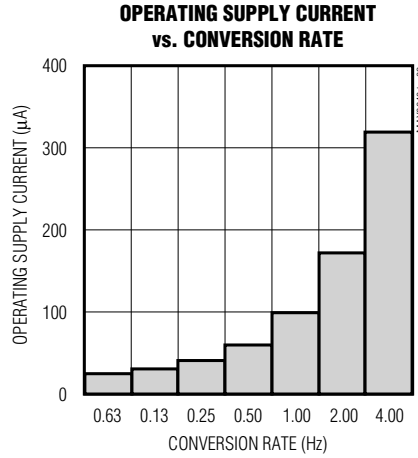
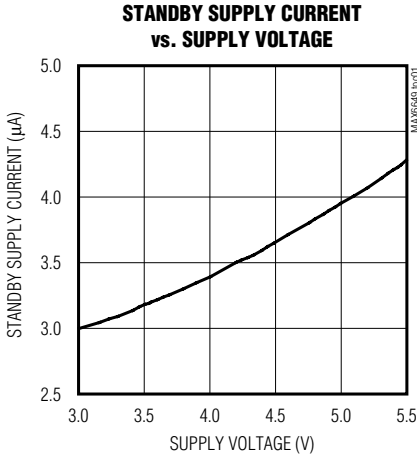

+145°C Precision SMBus-Compatible Remote/Local Sensors with Overtemperature Alarms

Pin Description

PIN	NAME	FUNCTION
1	V _{CC}	Supply Voltage Input, 3V to 5.5V. Bypass V _{CC} to GND with a 0.1µF capacitor. A 200Ω series resistor is recommended but not required for additional noise filtering.
2	DXP	Combined Remote-Diode Current Source and A/D Positive Input for Remote-Diode Channel. DO NOT LEAVE DXP UNCONNECTED ; connect DXP to DXN if no remote diode is used. Place a 2200pF capacitor between DXP and DXN for noise filtering.
3	DXN	Combined Remote-Diode Current Sink and A/D Negative Input. DXN is internally connected to ground.
4	$\overline{\text{OVERT}}$	Overtemperature Alert/Interrupt Output, Open Drain. $\overline{\text{OVERT}}$ is logic low when the temperature is above the software-programmed threshold.
5	GND	Ground
6	$\overline{\text{ALERT}}$	SMBus Alert (Interrupt) Output, Open Drain. $\overline{\text{ALERT}}$ asserts when temperature exceeds limits (high or low temperature). $\overline{\text{ALERT}}$ stays asserted until acknowledged by either reading the status register or by successfully responding to an alert response address, provided that the fault condition no longer exists. See the <i>ALERT Interrupts</i> section.
7	SDA	SMBus Serial-Data Input/Output, Open Drain
8	SCLK	SMBus Serial-Clock Input

Detailed Description

The MAX6646/MAX6647/MAX6649 are temperature sensors designed to work in conjunction with a microprocessor or other intelligence in thermostatic, process-control, or monitoring applications. Communication with the MAX6646/MAX6647/MAX6649 occurs through the SMBus-compatible serial interface and dedicated alert and overtemperature outputs. $\overline{\text{ALERT}}$ asserts if the measured local or remote temperature is greater than the software-programmed $\overline{\text{ALERT}}$ high limit or less than the $\overline{\text{ALERT}}$ low limit in the MAX6649. $\overline{\text{ALERT}}$ also asserts, in the MAX6649, if the remote-sensing diode pins are shorted or unconnected. The overtemperature alarm, $\overline{\text{OVERT}}$, asserts if the software-programmed $\overline{\text{OVERT}}$ limit is exceeded. $\overline{\text{OVERT}}$ can be connected to fans, a system shutdown, a clock throttle control, or other thermal-management circuitry.

The MAX6646/MAX6647/MAX6649 convert temperatures to digital data either at a programmed rate or in single conversions. Temperature data is represented as 11 bits, with the LSB equal to 0.125°C. The “main” temperature data registers (at addresses 00h and 01h) are 8-bit registers that represent the data as 8 bits with the full-scale reading indicating the diode fault status (Table 1). The remaining 3 bits of temperature data are available in the “extended” registers at addresses 11h and 10h (Table 2).

ADC and Multiplexer

The averaging ADC integrates over a 60ms period (each channel, typically), with excellent noise rejection. The multiplexer automatically steers bias currents through the remote and local diodes. The ADC and associated circuitry measure each diode’s forward voltage and compute the temperature based on this voltage. Both channels are automatically converted once the conversion process has started, either in free-running or single-shot mode. If one of the two channels is not used, the device still performs both measurements, and the results of the unused channel can be ignored. If the remote-diode channel is unused, connect DXP to DXN rather than leaving the inputs open.

Table 1. Main Temperature Data Register Format (00h, 01h)

TEMP (°C)	DIGITAL OUTPUT
+145	1001 0001
+130	1000 0010
+128	1000 0000
+25	0001 1001
0	0000 0000
<0	0000 0000
Diode fault (short or open)	1111 1111

+145°C Precision SMBus-Compatible Remote/Local Sensors with Overtemperature Alarms

The DXP-DXN differential input voltage range is 0.25V to 0.95V. Excess resistance in series with the remote diode causes +0.5°C (typ) error per ohm.

Remote Temperature Measurement Range

The MAX6646/MAX6647/MAX6649 measure remote temperatures significantly above the +120°C limit of many temperature sensors. External diode-connected transistors work well as temperature sensors up to approximately +145°C, where accuracy begins to degrade. Thermal diodes on some CPUs have characteristics that produce “apparent temperatures” far above actual operating temperatures. The MAX6646/MAX6647/MAX6649 measure apparent temperatures as high as +170°C, as long as the actual temperature is less than +145°C.

A/D Conversion Sequence

A conversion sequence consists of a local temperature measurement and a remote temperature measurement. Each time a conversion begins, whether initiated automatically in the free-running autonomous mode ($\overline{\text{RUN}} = 0$) or by writing a one-shot command, both channels are converted, and the results of both measurements are available after the end of a conversion. A BUSY status bit in the status byte indicates that the device is performing a new conversion. The results of the previous conversion are always available, even if the ADC is busy.

Low-Power Standby Mode

Standby mode reduces the supply current to less than 12 μA by disabling the ADC and timing circuitry. Enter standby mode by setting the $\overline{\text{RUN}}$ bit to 1 in the configuration byte register (Table 6). All data is retained in memory, and the SMBus interface is active and listening for SMBus commands. Standby mode is not a shutdown mode. With activity on the SMBus, the device draws more supply current (see *Typical Operating Characteristics*). In standby mode, the MAX6646/MAX6647/MAX6649 can be forced to perform A/D conversions through the one-shot command, regardless of the $\overline{\text{RUN}}$ bit status.

If a standby command is received while a conversion is in progress, the conversion cycle is truncated, and the data from that conversion is not latched into a temperature register. The previous data is not changed and remains available.

Supply-current drain during the 125ms conversion period is 250 μA (typ). Slowing down the conversion rate reduces the average supply current (see *Typical Operating Characteristics*). Between conversions, the conversion rate timer consumes 25 μA (typ) of supply current. In standby mode, supply current drops to 3 μA (typ).

SMBus Digital Interface

From a software perspective, the MAX6646/MAX6647/MAX6649 appear as a set of byte-wide registers that contain temperature data, alarm threshold values, and control bits. A standard SMBus-compatible 2-wire serial interface is used to read temperature data and write control bits and alarm threshold data.

The MAX6646/MAX6647/MAX6649 employ four standard SMBus protocols: write byte, read byte, send byte, and receive byte (Figures 1, 2, and 3). The shorter receive byte protocol allows quicker transfers, provided that the correct data register was previously selected by a read byte instruction. Use caution when using the shorter protocols in multimaster systems, as a second master could overwrite the command byte without informing the first master.

Temperature data can be read from the read internal temperature (00h) and read external temperature (01h) registers. The temperature data format for these registers is 8 bits for each channel, with the LSB representing 1°C (Table 1). The MSB is transmitted first.

An additional 3 bits can be read from the read external extended temperature register (10h), which extends the data to 11 bits and the resolution to 0.125°C per LSB. An additional 3 bits can be read from the read internal extended temperature register (11h), which extends the data to 11 bits and the resolution to 0.125°C per LSB (Table 2).

When a conversion is complete, the main temperature register and the extended temperature register are updated simultaneously. Ensure that no conversions are completed between reading the main register and the extended register, so that both registers contain the result of the same conversion.

Table 2. Extended Resolution Temperature Register Data Format (10h, 11h)

FRACTIONAL TEMP (°C)	DIGITAL OUTPUT
0.000	000X XXXX
0.125	001X XXXX
0.250	010X XXXX
0.375	011X XXXX
0.500	100X XXXX
0.625	101X XXXX
0.750	110X XXXX
0.875	111X XXXX

+145°C Precision SMBus-Compatible Remote/Local Sensors with Overtemperature Alarms

MAX6646/MAX6647/MAX6649

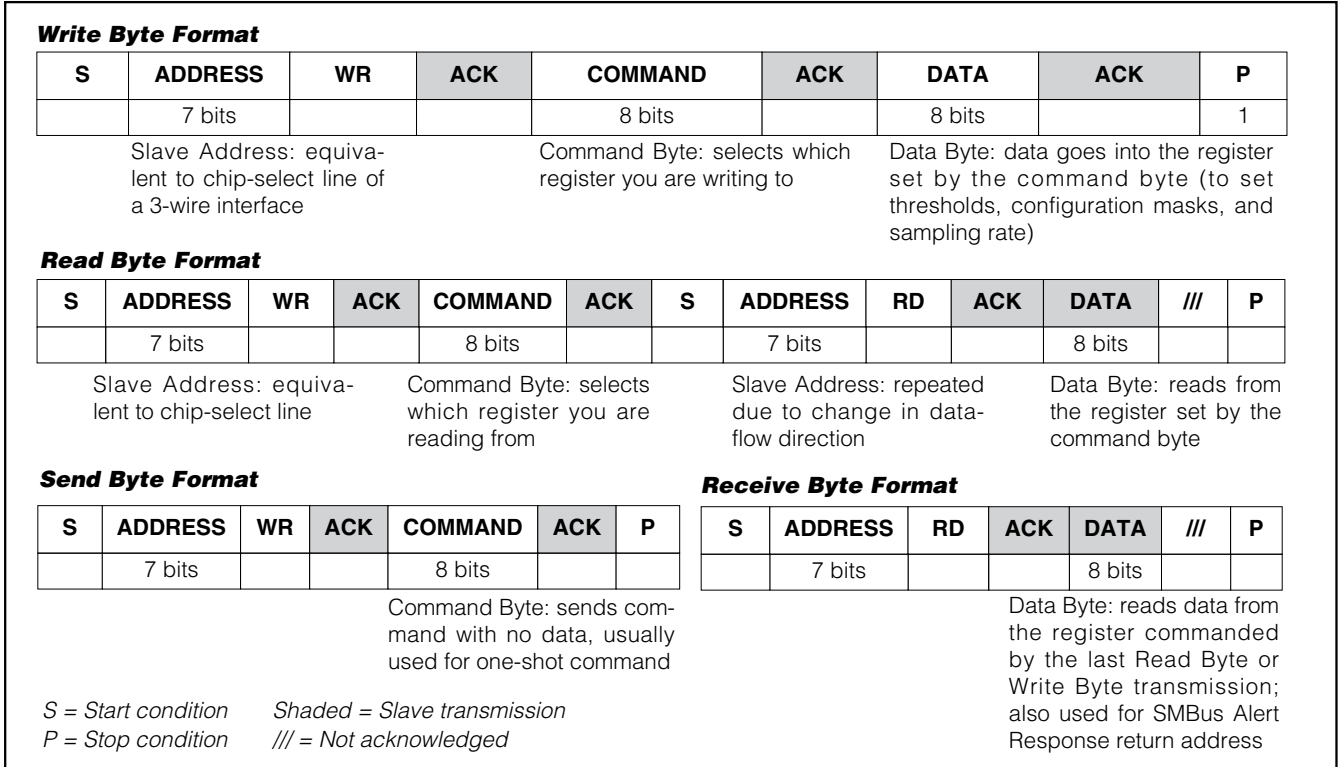

Figure 1. SMBus Protocols

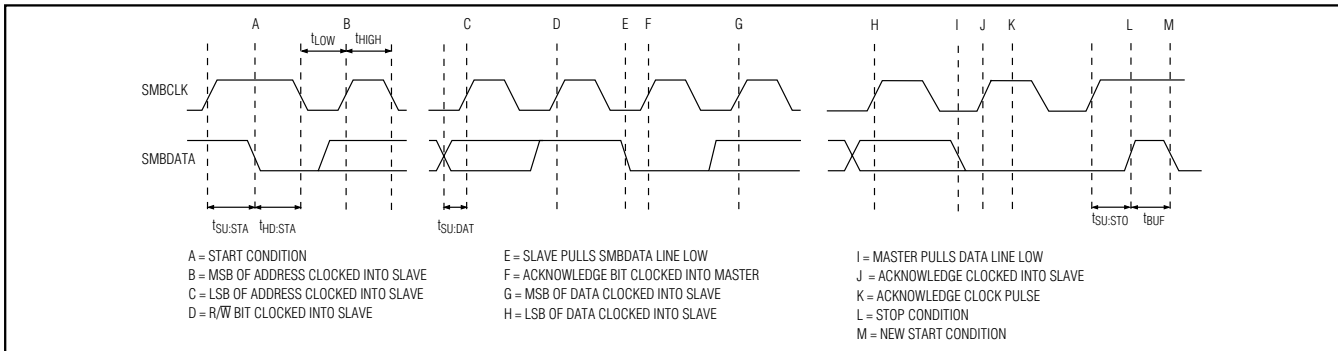

Figure 2. SMBus Write Timing Diagram

To ensure valid extended data, read extended resolution temperature data using one of the following approaches:

- Put the MAX6646/MAX6647/MAX6649 into standby mode by setting bit 6 of the configuration register to 1. Initiate a one-shot conversion using command byte 0Fh. When this conversion is complete, read the contents of the temperature data registers.

- If the MAX6646/MAX6647/MAX6649 is in run mode, read the status byte. If the BUSY bit indicates that a conversion is in progress, wait until the conversion is complete (BUSY bit set to zero) before reading the temperature data. Following a conversion completion, immediately read the contents of the temperature data registers. If no conversion is in progress, the data can be read within a few microseconds, which is a sufficiently short period of time to ensure that a new conversion cannot be completed until after the data has been read.

+145°C Precision SMBus-Compatible Remote/Local Sensors with Overtemperature Alarms

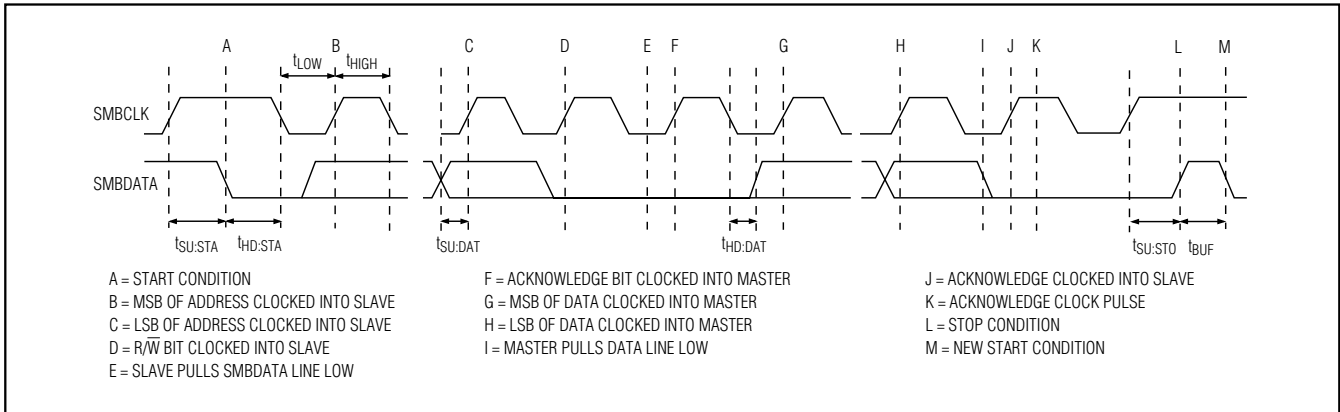

Figure 3. SMBus Read Timing Diagram

Alarm Threshold Registers

Four registers store $\overline{\text{ALERT}}$ threshold values—one high-temperature (T_{HIGH}) and one low-temperature (T_{LOW}) register each for the local and remote channels. If either measured temperature equals or exceeds the corresponding $\overline{\text{ALERT}}$ threshold value, the $\overline{\text{ALERT}}$ interrupt asserts.

The MAX6646/MAX6647 local (internal) $\overline{\text{ALERT}}$ T_{HIGH} register POR state is 0101 0101, or +85°C, while the remote (external) $\overline{\text{ALERT}}$ T_{HIGH} register POR state is 0101 1111, or +95°C. The MAX6649 POR state of both $\overline{\text{ALERT}}$ T_{HIGH} registers is 0101 0101, or +85°C. The POR state of the local and remote T_{LOW} registers for all devices is 0000 0000, or 0°C.

Two additional registers store remote and local alarm threshold data corresponding to the $\overline{\text{OVERT}}$ output. The values stored in these registers are high-temperature thresholds. If either of the measured temperatures equals or exceeds the corresponding alarm threshold value, an $\overline{\text{OVERT}}$ output asserts. The MAX6646/MAX6647 local (internal) $\overline{\text{OVERT}}$ register POR state is 0101 0101, or +85°C, while the remote (external) $\overline{\text{OVERT}}$ register POR state is 0111 1101, or +125°C. The MAX6649 POR state of both $\overline{\text{OVERT}}$ registers is 0101 0101, or +85°C.

Diode Fault Alarm

A continuity fault detector at DXP detects an open circuit between DXP and DXN, or a DXP short to V_{CC} , GND, or DXN. If an open or short circuit exists, the external temperature register is loaded with 1111 1111. If the fault is an open-circuit fault bit 2 ($\overline{\text{OPEN}}$), the status byte is set to 1. In the MAX6649, $\overline{\text{ALERT}}$ is activated at the end of the conversion. Immediately after POR, the status register indicates that no fault is present. If a fault is present upon power-up, the fault is not indicated until the end of the first conversion.

$\overline{\text{ALERT}}$ Interrupts

The $\overline{\text{ALERT}}$ interrupt occurs when the internal or external temperature reading exceeds a high- or low-temperature limit (programmed) or in the MAX6649, when the remote diode is disconnected (for continuity fault detection). The $\overline{\text{ALERT}}$ interrupt output signal is latched and can be cleared only by either reading the status register or by successfully responding to an alert response address. In both cases, the alert is cleared if the fault condition no longer exists. Asserting $\overline{\text{ALERT}}$ does not halt automatic conversion. The $\overline{\text{ALERT}}$ output is open drain, allowing multiple devices to share a common interrupt line.

The MAX6646/MAX6647/MAX6649 respond to the SMBus alert response address, an interrupt pointer return-address feature (see the *Alert Response Address* section). Prior to taking corrective action, always check to ensure that an interrupt is valid by reading the current temperature.

Fault Queue Register

In some systems, it may be desirable to ignore a single temperature measurement that falls outside the $\overline{\text{ALERT}}$ limits. Bits 1 and 2 of the fault queue register (address 22h) determine the number of consecutive temperature faults necessary to set $\overline{\text{ALERT}}$ (see Tables 3 and 4).

Alert Response Address

The SMBus alert response interrupt pointer provides quick fault identification for simple slave devices that lack the complex, expensive logic needed to be a bus master. Upon receiving an $\overline{\text{ALERT}}$ interrupt signal, the host master can broadcast a receive byte transmission to the alert response slave address (0001 100). Following such a broadcast, any slave device that generated an interrupt attempts to identify itself by putting its own address on the bus.

+145°C Precision SMBus-Compatible Remote/Local Sensors with Overtemperature Alarms

Table 3. Fault Queue Register Bit Definition (22h)

BIT	NAME	POR STATE	FUNCTION
7	RFU	1	Reserved. Always write 1 to this bit.
6 to 3	RFU	0	Reserved. Always write zero to this bit.
2	FQ1	1	Fault queue-length control bit (see Table 4).
1	FQ0	1	Fault queue-length control bit (see Table 4).
0	RFU	0	Reserved. Always write zero to this bit.

The alert response can activate several different slave devices simultaneously, similar to the I²C general call. If more than one slave attempts to respond, bus arbitration rules apply, and the device with the lower address code wins. The losing device does not generate an acknowledge and continues to hold the ALERT line low until cleared. (The conditions for clearing an ALERT vary, depending on the type of slave device). Successful completion of the read alert response protocol clears the interrupt latch, provided the condition that caused the alert no longer exists.

OVERT Overtemperature Alarm/Warning Outputs

OVERT asserts when the temperature rises to a value stored in one of the OVERT limit registers (19h, 20h). It deasserts when the temperature drops below the stored limit, minus hysteresis. OVERT can be used to activate a cooling fan, send a warning, invoke clock throttling, or trigger a system shutdown to prevent component damage.

Command Byte Functions

The 8-bit command byte register (Table 5) is the master index that points to the various other registers within the MAX6646/MAX6647/MAX6649. The register's POR state is 0000 0000, so a receive byte transmission (a protocol that lacks the command byte) that occurs immediately after POR, returns the current local temperature data.

The MAX6646/MAX6647/MAX6649 incorporate collision avoidance so that completely asynchronous operation is allowed between SMBus operations and temperature conversions.

Table 4. Fault Queue Length Bit Definition

FQ1	FQ0	FAULT QUEUE LENGTH (SAMPLES)
0	0	1
0	1	2
1	1	3
1	0	1

One-Shot

The one-shot command immediately forces a new conversion cycle to begin. If the one-shot command is received while the MAX6646/MAX6647/MAX6649 are in standby mode (RUN bit = 1), a new conversion begins, after which the device returns to standby mode. If a one-shot conversion is in progress when a one-shot command is received, the command is ignored. If a one-shot command is received in autonomous mode (RUN bit = 0) between conversions, a new conversion begins, the conversion rate timer is reset, and the next automatic conversion takes place after a full delay elapses.

Configuration Byte Functions

The configuration byte register (Table 6) is a read-write register with several functions. Bit 7 is used to mask (disable) interrupts. Bit 6 puts the MAX6646/MAX6647/MAX6649 into standby mode (STOP) or autonomous (RUN) mode.

Status Byte Functions

The status byte register (Table 7) indicates which (if any) temperature thresholds have been exceeded. This byte also indicates whether the ADC is converting and whether there is an open-circuit fault detected in the external sense junction. After POR, the normal state of all flag bits is zero, assuming no alarm conditions are present. The status byte is cleared by any successful read of the status byte, after conversion is complete and if the fault condition no longer exists. Note that the ALERT interrupt latch is not automatically cleared when the status flag bit indicating the ALERT is cleared. The fault condition must be eliminated before the ALERT output can be cleared.

When autoconverting, if the T_{HIGH} and T_{LOW} limits are close together, it is possible for both high-temp and low-temp status bits to be set, depending on the amount of time between status read operations (especially when converting at the fastest rate). In these circumstances, it is best not to rely on the status bits to indicate reversals in long-term temperature changes. Instead use a current temperature reading to establish the trend direction.

+145°C Precision SMBus-Compatible Remote/Local Sensors with Overtemperature Alarms

Table 5. Command-Byte Bit Assignments

REGISTER	ADDRESS	POR STATE		FUNCTION
RLTS	00h	0000 0000	0°C	Read local (internal) temperature
RRTE	01h	0000 0000	0°C	Read remote (external) temperature
RSL	02h	N/A	—	Read status byte
RCL	03h	0000 0000	—	Read configuration byte
RCRA	04h	0000 0111	—	Read conversion rate byte
RLHN	05h	0101 0101	+85°C	Read local (internal) $\overline{\text{ALERT}}$ high limit
RLLI	06h	0000 0000	0°C	Read local (internal) $\overline{\text{ALERT}}$ low limit
RRHI	07h	0101 1111	+95°C	Read remote (external) $\overline{\text{ALERT}}$ high limit (MAX6646/MAX6647)
		0101 0101	+85°C	Read remote (external) $\overline{\text{ALERT}}$ high limit (MAX6649)
RRLS	08h	0000 0000	0°C	Read remote (external) $\overline{\text{ALERT}}$ low limit
WCA	09h	N/A	—	Write configuration byte
WCRW	0Ah	N/A	—	Write conversion rate byte
WLHO	0Bh	N/A	—	Write local (internal) $\overline{\text{ALERT}}$ high limit
WLLM	0Ch	N/A	—	Write local (internal) $\overline{\text{ALERT}}$ low limit
WRHA	0Dh	N/A	—	Write remote (external) $\overline{\text{ALERT}}$ high limit
WRLN	0Eh	N/A	—	Write remote (external) $\overline{\text{ALERT}}$ low limit
OSHT	0Fh	N/A	—	One-shot
REET	10h	0000 0000	0°C	Read remote (external) extended temperature
RIET	11h	0000 0000	0°C	Read local (internal) extended temperature
RWOE	19h	0111 1101	+125°C	Read/write remote (external) $\overline{\text{OVERT}}$ limit (MAX6646/MAX6647)
		0101 0101	+85°C	Read/write remote (external) $\overline{\text{OVERT}}$ limit (MAX6649)
RWOI	20h	0101 0101	+85°C	Read/write local (internal) $\overline{\text{OVERT}}$ limit
HYS	21h	0000 1010	10°C	Overtemperature hysteresis
QUEUE	22h	1000 0110	—	Fault queue
—	FEh	0100 1101	—	Read manufacture ID
—	FFh	0101 1001	—	Read revision ID

Table 6. Configuration-Byte Bit Assignments (03h)

BIT	NAME	POR STATE	FUNCTION
7 (MSB)	MASK	0	Masks $\overline{\text{ALERT}}$ interrupts when set to 1.
6	$\overline{\text{RUN}}$	0	Standby mode control bit; if set to 1, standby mode is initiated.
5 to 0	RFU	0	Reserved.

Conversion Rate Byte

The conversion rate register (Table 8) programs the time interval between conversions in free-running autonomous mode ($\overline{\text{RUN}} = 0$). This variable rate control can be used to reduce the supply current in portable-equipment applications. The conversion rate byte's POR state is 07h or 4Hz. The MAX6646/MAX6647/MAX6649 look only at the 3 LSBs of this register, so the upper 5 bits are "don't care" bits, which should be set to zero. The conversion rate tolerance is $\pm 25\%$ at any rate setting.

Valid A/D conversion results for both channels are available two total conversion times (250ms nominal, 312ms maximum) after initiating a conversion, whether conversion is initiated through the $\overline{\text{RUN}}$ bit, one-shot command, or initial power-up. Changing the conversion rate can also affect the delay until new results are available.

+145°C Precision SMBus-Compatible Remote/ Local Sensors with Overtemperature Alarms

MAX6646/MAX6647/MAX6649

Table 7. Status Register Bit Assignments (02h)

BIT	NAME	POR STATE	FUNCTION
7 (MSB)	BUSY	0	A/D is busy converting when 1.
6	LHIGH	0	Local (internal) high-temperature alarm has tripped when 1; cleared by POR or readout of the status byte if the fault condition no longer exists.
5	LLOW	0	Local (internal) low-temperature alarm has tripped when 1; cleared by POR or readout of the status byte if the fault condition no longer exists.
4	RHIGH	0	Remote (external) high-temperature alarm has tripped when 1; cleared by POR or readout of the status byte if the fault condition no longer exists.
3	RLOW	0	Remote (external) low-temperature alarm has tripped when 1; cleared by POR or readout of the status byte if the fault condition no longer exists.
2	FAULT	0	A 1 indicates DXN and DXP are either shorted or open; cleared by POR or readout of the status byte if the fault condition no longer exists.
1	EOT	0	A 1 indicates the remote (external) junction temperature exceeds the external $\overline{\text{OVERT}}$ threshold.
0	IOT	0	A 1 indicates the local (internal) junction temperature exceeds the internal $\overline{\text{OVERT}}$ threshold.

Slave Addresses

The MAX6646/MAX6647/MAX6649 have fixed slave addresses (see Table 9). All devices also respond to the SMBus alert response slave address (see the *Alert Response Address* section).

POR and UVLO

To prevent ambiguous power-supply conditions from corrupting the data in memory and causing erratic behavior, a POR voltage detector monitors V_{CC} and clears the memory if V_{CC} falls below 2.0V (typ). When power is first applied and V_{CC} rises above 2.0V (typ), the logic blocks begin operating, although reads and writes at V_{CC} levels below 3V are not recommended. A second V_{CC} comparator, the ADC UVLO comparator, prevents the ADC from converting until there is sufficient headroom ($V_{CC} = 2.7V$ typ).

Power-Up Defaults

Power-up defaults include:

- Interrupt latch is cleared.
- ADC begins autoconverting at a 4Hz rate.
- Command byte is set to 00h to facilitate quick local temperature receive byte queries.
- Local (internal) T_{HIGH} limit is set to +85°C.
- Local (internal) T_{LOW} limit is set to 0°C.
- Remote (external) T_{HIGH} limit is set to +85°C (MAX6649)/+95°C (MAX6646/MAX6647)
- $\overline{\text{OVERT}}$ (internal) limit is set to +85°C
- $\overline{\text{OVERT}}$ (external) limit is set to +85°C (MAX6649)/+125°C (MAX6646/MAX6647)

Table 8. Conversion-Rate Control Byte (04h)

DATA	CONVERSION RATE (Hz)
00h	0.0625
01h	0.125
02h	0.25
03h	0.5
04h	1
05h	2
06h	4
07h	4
08h-FFh	Reserved

Table 9. Slave Addresses

PART	SLAVE ADDRESS
MAX6646	1001 101
MAX6647	1001 110
MAX6649	1001 100

+145°C Precision SMBus-Compatible Remote/Local Sensors with Overtemperature Alarms

Applications Information

Remote-Diode Selection

The MAX6646/MAX6647/MAX6649 can directly measure the die temperature of CPUs and other ICs that have on-board temperature-sensing diodes (see *Typical Operating Circuit*), or they can measure the temperature of a discrete diode-connected transistor.

Effect of Ideality Factor

The accuracy of the remote temperature measurements depends on the ideality factor (n) of the remote "diode" (actually a transistor). The MAX6646/MAX6647/MAX6649 are optimized for $n = 1.008$, which is the typical value for the Intel® Pentium® III and the AMD Athlon MP model 6. If a sense transistor with a different ideality factor is used, the output data is different. Fortunately, the difference is predictable.

Assume a remote-diode sensor designed for a nominal ideality factor n_{NOMINAL} is used to measure the temperature of a diode with a different ideality factor n_1 . The measured temperature T_M can be corrected using:

$$T_M = T_{\text{ACTUAL}} \left(\frac{n_1}{n_{\text{NOMINAL}}} \right)$$

where temperature is measured in Kelvin.

As mentioned above, the nominal ideality factor of the MAX6646/MAX6647/MAX6649 is 1.008. The following example uses the MAX6646/MAX6647/MAX6649 with a CPU that has an ideality factor of 1.002. If the diode has no series resistance, the measured data is related to the real temperature as follows:

$$T_{\text{ACTUAL}} = T_M \left(\frac{n_{\text{NOMINAL}}}{n_1} \right) = T_M \left(\frac{1.008}{1.002} \right) = T_M(1.00599)$$

For a real temperature of +85°C (358.15 K), the measured temperature is +82.91°C (356.02 K), which is an error of -2.13°C.

Effect of Series Resistance

Series resistance in a sense diode contributes additional errors. For nominal diode currents of 10 μ A and 100 μ A, change in the measured voltage is:

$$\Delta V_M = R_S(100\mu\text{A} - 10\mu\text{A}) = 90\mu\text{A} \times R_S$$

Since 1°C corresponds to 198.6 μ V, series resistance contributes a temperature offset of:

*Intel and Pentium are registered trademarks of Intel Corp.
AMD and Athlon are trademarks of Advanced Micro Devices, Inc.*

$$\frac{90 \frac{\mu\text{V}}{\Omega}}{198.6 \frac{\mu\text{V}}{^\circ\text{C}}} = 0.453 \frac{^\circ\text{C}}{\Omega}$$

Assume that the diode being measured has a series resistance of 3 Ω . The series resistance contributes an offset of:

$$3\Omega \times 0.453 \frac{^\circ\text{C}}{\Omega} = 1.36^\circ\text{C}$$

The effects of the ideality factor and series resistance are additive. If the diode has an ideality factor of 1.002 and series resistance of 3 Ω , the total offset can be calculated by adding error due to series resistance with error due to ideality factor:

$$1.36^\circ\text{C} - 2.13^\circ\text{C} = -0.77^\circ\text{C}$$

for a diode temperature of +85°C.

In this example, the effect of the series resistance and the ideality factor partially cancel each other.

Discrete Remote Diodes

When the remote-sensing diode is a discrete transistor, short the collector to the base. Table 10 lists examples of discrete transistors that are appropriate for use with the MAX6646/MAX6647/MAX6649.

Avoid violating the A/D input voltage range by using a small-signal transistor with a relatively high forward voltage. The forward voltage at the highest expected temperature must be greater than 0.25V at 10 μ A, and the forward voltage at the lowest expected temperature must be less than 0.95V at 100 μ A. Do not use large power transistors. Ensure that the base resistance is less than 100 Ω . Tight specifications for forward current gain ($50 < \beta < 150$, for example) indicate that the manufacturer has good process controls and that the devices have consistent V_{BE} characteristics.

Table 10. Remote-Sensor Transistor Manufactures

MANUFACTURER	MODEL NO.
Central Semiconductor (USA)	CMPT3904
Rohm Semiconductor (USA)	SST3904
Samsung (Korea)	KST3904-TF
Siemens (Germany)	SMBT3904
Zetex (England)	FMMT3904CT-ND

Note: Discrete transistors must be diode connected (base shorted to collector).

+145°C Precision SMBus-Compatible Remote/Local Sensors with Overtemperature Alarms

MAX6646/MAX6647/MAX6649

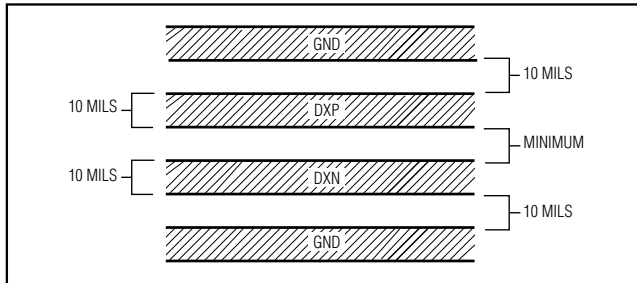

Figure 4. Recommended DXP-DXN PC Traces

ADC Noise Filtering

The integrating ADC used has good noise rejection for low-frequency signals such as 60Hz/120Hz power-supply hum. In noisy environments, high-frequency noise reduction is needed for high-accuracy remote measurements. The noise can be reduced with careful PC board layout and proper external noise filtering.

High-frequency EMI is best filtered at DXP and DXN with an external 2200pF capacitor. Larger capacitor values can be used for added filtering, but do not exceed 3300pF because larger values can introduce errors due to the rise time of the switched current source.

PC Board Layout

Follow these guidelines to reduce the measurement error of the temperature sensors:

- 1) Place the MAX6646/MAX6647/MAX6649 as close as is practical to the remote diode. In noisy environments, such as a computer motherboard, this distance can be 4in to 8in (typ). This length can be increased if the worst noise sources are avoided. Noise sources include CRTs, clock generators, memory buses, and ISA/PCI buses.
- 2) Do not route the DXP-DXN lines next to the deflection coils of a CRT. Also, do not route the traces across fast digital signals, which can easily introduce 30°C error, even with good filtering.
- 3) Route the DXP and DXN traces in parallel and in close proximity to each other, away from any higher voltage traces, such as 12VDC. Leakage currents from PC board contamination must be dealt with carefully since a 20M Ω leakage path from DXP to ground causes about 1°C error. If high-voltage traces are unavoidable, connect guard traces to GND on either side of the DXP-DXN traces (Figure 4).
- 4) Route through as few vias and crossunders as possible to minimize copper/solder thermocouple effects.

- 5) When introducing a thermocouple, make sure that both the DXP and the DXN paths have matching thermocouples. A copper-solder thermocouple exhibits 3 μ V/°C, and takes about 200 μ V of voltage error at DXP-DXN to cause a 1°C measurement error. Adding a few thermocouples causes a negligible error.
- 6) Use wide traces. Narrow traces are more inductive and tend to pick up radiated noise. The 10mil widths and spacing recommended in Figure 4 are not absolutely necessary, as they offer only a minor improvement in leakage and noise over narrow traces. Use wider traces when practical.
- 7) Add a 200 Ω resistor in series with V_{CC} for best noise filtering (see *Typical Operating Circuit*).
- 8) Copper cannot be used as an EMI shield; only ferrous materials such as steel work well. Placing a copper ground plane between the DXP-DXN traces and traces carrying high-frequency noise signals does not help reduce EMI.

Twisted-Pair and Shielded Cables

Use a twisted-pair cable to connect the remote sensor for remote-sensor distance longer than 8in, or in very noisy environments. Twisted-pair cable lengths can be between 6ft and 12ft before noise introduces excessive errors. For longer distances, the best solution is a shielded twisted pair like that used for audio microphones. For example, Belden 8451 works well for distances up to 100ft in a noisy environment. At the device, connect the twisted pair to DXP and DXN and the shield to GND. Leave the shield unconnected at the remote sensor.

For very long cable runs, the cable's parasitic capacitance often provides noise filtering, so the 2200pF capacitor can often be removed or reduced in value. Cable resistance also affects remote-sensor accuracy. For every 1 Ω of series resistance, the error is approximately 0.5°C.

Thermal Mass and Self-Heating

When sensing local temperature, these devices are intended to measure the temperature of the PC board to which the devices are soldered. The leads provide a good thermal path between the PC board traces and the die. Thermal conductivity between the die and the ambient air is poor by comparison, making air temperature measurements impractical. Because the thermal mass of the PC board is far greater than that of the MAX6646/MAX6647/MAX6649, the device follows temperature changes on the PC board with little or no perceivable delay.

+145°C Precision SMBus-Compatible Remote/Local Sensors with Overtemperature Alarms

When measuring the temperature of a CPU or other IC with an on-chip sense junction, thermal mass has virtually no effect; the measured temperature of the junction tracks the actual temperature within a conversion cycle. When measuring temperature with discrete remote sensors, smaller packages, such as SC70s or SOT23s, yield the best thermal response times. Take care to account for thermal gradients between the heat source and the sensor, and ensure that stray air currents across the sensor package do not interfere with measurement accuracy.

Self-heating does not significantly affect measurement accuracy. Remote-sensor self-heating due to the diode current source is negligible. For the local diode, the worst-case error occurs when autoconverting at the fastest rate and simultaneously sinking maximum current at the $\overline{\text{ALERT}}$ output. For example, with $V_{CC} = 5.0\text{V}$, at a 4Hz conversion rate and with $\overline{\text{ALERT}}$ sinking 1mA, the typical power dissipation is:

$$5.0\text{V} \times 500\mu\text{A} + 0.4\text{V} \times 1\text{mA} = 2.9\text{mW}$$

Θ_{J-A} for the 8-pin μMAX package is +221°C/W, so assuming no copper PC board heat sinking, the resulting temperature rise is:

$$\Delta T = 2.9\text{mW} \times +221^\circ\text{C/W} = +0.6409^\circ\text{C}$$

Even under nearly worst-case conditions, it is difficult to introduce a significant self-heating error.

Functional Diagram

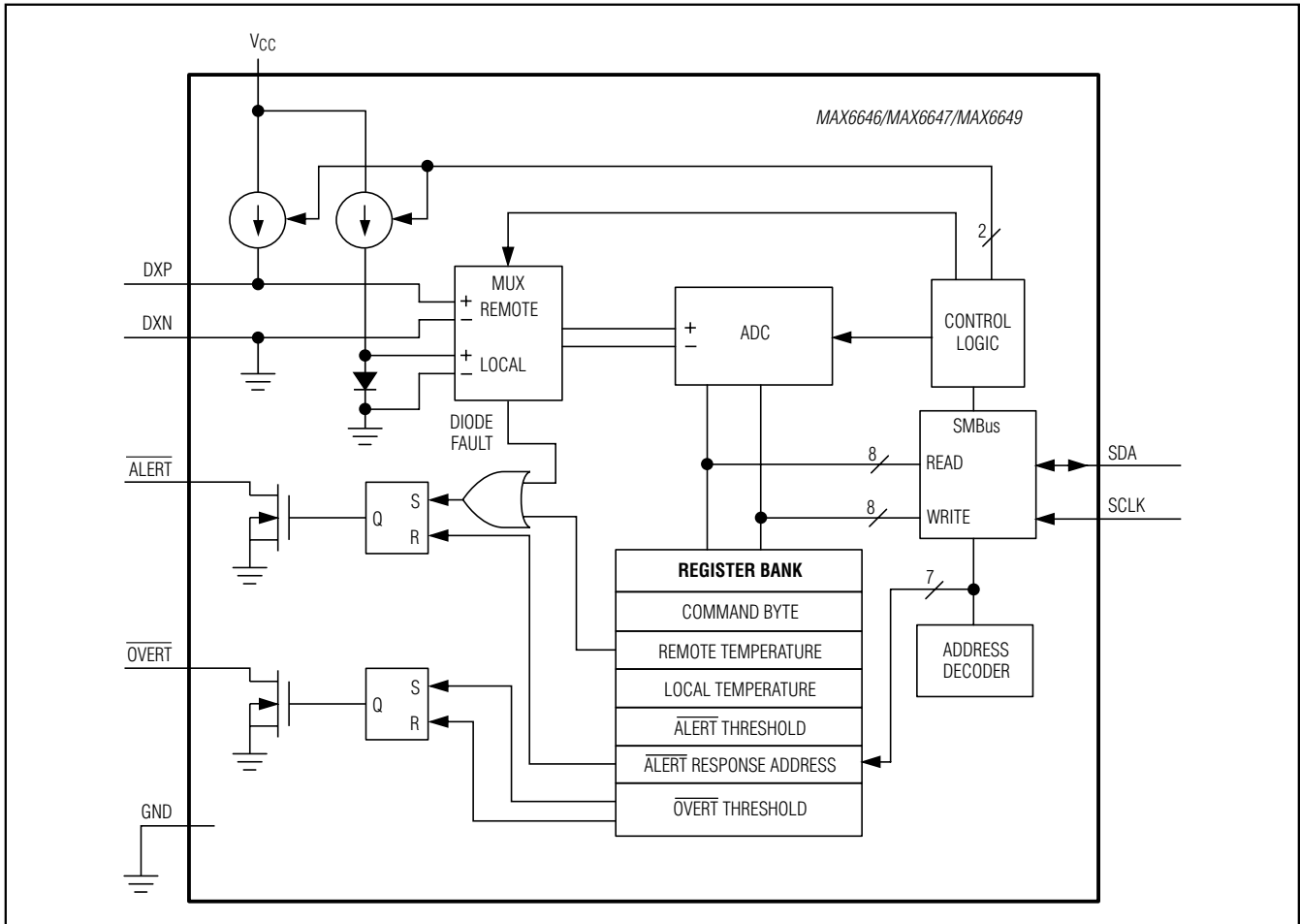

+145°C Precision SMBus-Compatible Remote/ Local Sensors with Overtemperature Alarms

Selector Guide

PART	ADDRESS	POR VALUES		ALERT ASSERTED WHILE DIODE OPEN
		EXTERNAL $\overline{\text{OVERT}}$ LIMIT (°C)	EXTERNAL $\overline{\text{ALERT}}_{\text{THIGH}}$ LIMIT (°C)	
MAX6646	1001 101	+125	+95	No
MAX6647	1001 110	+125	+95	No
MAX6649	1001 100	+85	+85	Yes

Pin Configuration

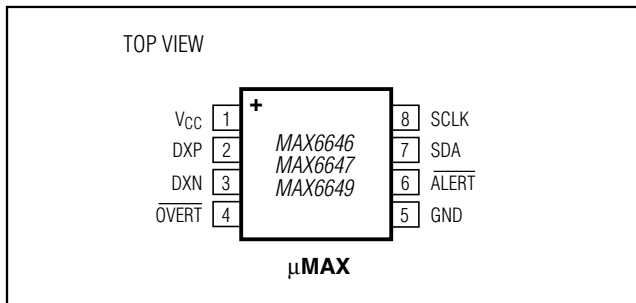

Chip Information

PROCESS: BiCMOS

Package Information

For the latest package outline information and land patterns (footprints), go to www.maxim-ic.com/packages. Note that a "+", "#", or "-" in the package code indicates RoHS status only. Package drawings may show a different suffix character, but the drawing pertains to the package regardless of RoHS status.

PACKAGE TYPE	PACKAGE CODE	OUTLINE NO.	LAND PATTERN NO.
8 μMAX	U8+1	21-0036	90-0092

MAX6646/MAX6647/MAX6649

+145°C Precision SMBus-Compatible Remote/ Local Sensors with Overtemperature Alarms

Revision History

REVISION NUMBER	REVISION DATE	DESCRIPTION	PAGES CHANGED
4	7/12	Updated the <i>Ordering Information</i> table to include lead-free packages; added the soldering temperature value to the <i>Absolute Maximum Ratings</i> section; added the <i>Package Information</i> table; updated the <i>Electrical Characteristics</i> table for the following: 1) Removed the START Condition Setup Time parameter 2) Changed $t_{SU:STA(MIN)}$ from 50ns to 4.7ns and removed the 90% to 90% condition 3) Updated the Data Setup Time parameter symbol and added the Data Hold Time parameter	1, 2, 3, 15

Maxim cannot assume responsibility for use of any circuitry other than circuitry entirely embodied in a Maxim product. No circuit patent licenses are implied. Maxim reserves the right to change the circuitry and specifications without notice at any time. The parametric values (min and max limits) shown in the Electrical Characteristics table are guaranteed. Other parametric values quoted in this data sheet are provided for guidance.

16 **Maxim Integrated Products, Inc. 160 Rio Robles, San Jose, CA 95134 USA 1-408-601-1000**