

MAX78615+PPM

Isolated Energy Measurement Processor for Polyphase Monitoring Systems

General Description

The MAX78615+PPM is part of an isolated energy measurement processor (EMP) chipset for polyphase power monitoring systems. It is designed for real-time monitoring for a variety of typical three-phase configurations in industrial applications.

The device provides flexible sensor configuration for up to three MAX78700s or MAX71071s that provide up to six isolated analog inputs for interfacing to voltage and current sensors. Scaled voltages from the sensors are fed to the isolated front-end utilizing a high-resolution delta-sigma converter. Supported current sensors include resistive shunts and current transformers (CTs).

An embedded 24-bit measurement processor and firmware perform all necessary computations and data formatting for accurate reporting to the host. With integrated flash memory for storing nonvolatile calibration coefficients and device configuration settings, the MAX78615+PPM can be a completely autonomous solution.

The MAX78615+PPM is designed to interface to the host processor through the UART, SPI, or I²C interfaces, and is available in a 24-pin TQFN package.

Applications

- Polyphase Submetering
- Building Automation Systems
- Inverters and Renewable Energy Systems
- Level 1 and 2 EV Charging Systems
- Grid-Friendly Appliances and Smart Plugs

Benefits and Features

- Best-In-Class Embedded Algorithms Support Highly Accurate Electricity Measurements
 - Voltage, Current, and Frequency
 - Active, Reactive, and Apparent Power/Energy
 - Power Quality Measurements Including Peak Current and Harmonic Content
 - Digital Temperature Compensation
- Configurable Device Provides Design Flexibility
 - Nonvolatile Storage of Calibration and Configuration Parameters.
 - SPI, I²C, or UART Interface Options
 - Configurable I/O Pins for Alarm Signaling, Address Pins, or User Control
- Highly Integrated Features Support Compact Designs and Reduced Bill of Materials
 - Small 24-Pin TQFN Package
 - Internal or External Oscillator Timing References
 - Three Remote ADC Interfaces Provide Cost-Effective and Reliable Isolation
 - Quick Calibration Routines Minimize Manufacturing (System) Cost
 - Digital Temperature Compensation

Ordering Information appears at end of data sheet.

Simplified Block Diagram

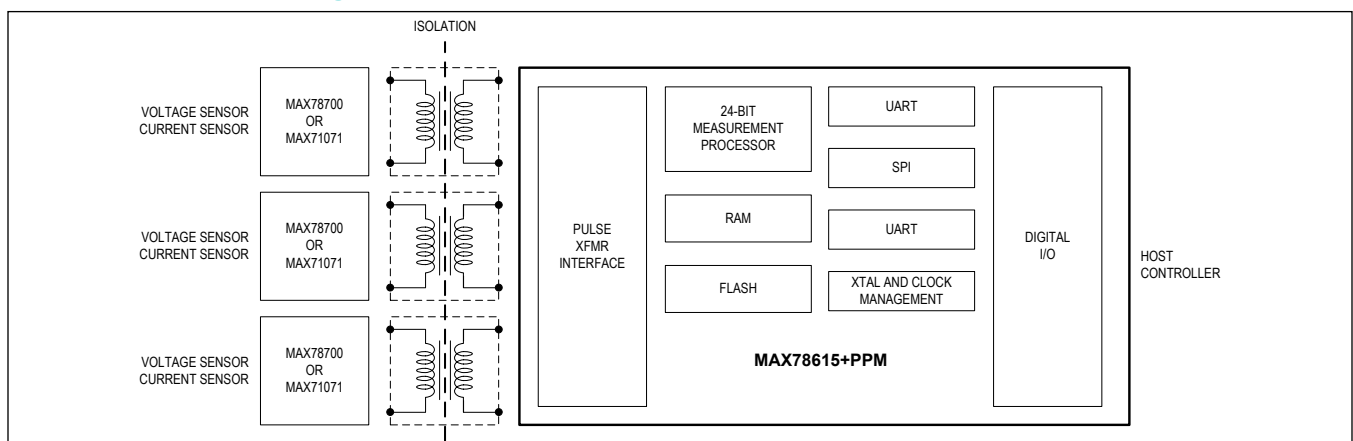

Absolute Maximum Ratings

Supplies and Ground Pins

V_{DD}.....-0.5V to 4.6V
GND.....-0.5V to +0.5V

Analog Input Pins

AV1, AV2, AV3, AI1, AI2, AI3-10mA to +10mA
-0.5V to (V_{DD} + 0.5V)

Oscillator Pins:

XIN, XOUT.....-10mA to +10mA
-0.5V to 3.0V

Digital Pins:

Digital Pins Configured as Outputs-30mA to +30mA,
-0.5 to (V_{DD} + 0.5V)

RESET and Digital Pins

Configured as Inputs-10mA to +10mA,
-0.5V to +6V

Operating Junction Temperature

Peak, 100ms.....+140°C
Continuous.....+125°C
Storage Temperature Range-45°C to +165°C
Lead Temperature (soldering, 10s)+260°C
Soldering Temperature (reflow)+300°C
ESD Stress on All Pins.....±4kV

Stresses beyond those listed under "Absolute Maximum Ratings" may cause permanent damage to the device. These are stress ratings only, and functional operation of the device at these or any other conditions beyond those indicated in the operational sections of the specifications is not implied. Exposure to absolute maximum rating conditions for extended periods may affect device reliability.

Recommended External Components

NAME	FROM	TO	FUNCTION	VALUE	UNITS
XTAL	XIN	XOUT	20.000MHz	20.000	MHz
CXS	XIN	GND	Load capacitor for crystal (exact value depends on crystal specifications and parasitic capacitance of board)	18 ±10%	pF
CXL	XOUT	GND		18 ±10%	pF

Recommended Operating Conditions

PARAMETER	CONDITIONS	MIN	TYP	MAX	UNITS
3.3V Supply Voltage (V _{DD})	Normal operation	3.0	3.3	3.6	V
Operating Temperature		-40		+85	°C

Performance Specifications

(Note that production tests are performed at room temperature.)

PARAMETER	CONDITIONS	MIN	TYP	MAX	UNITS
INPUT LOGIC LEVELS					
Digital High-Level Input Voltage (V _{IH})		2			V
Digital Low-Level Input Voltage (V _{IL})				0.8	V
OUTPUT LOGIC LEVELS					
Digital High-Level Output Voltage (V _{OH})	I _{LOAD} = 1mA	V _{DD} - 0.4			V
	I _{LOAD} = 10mA	V _{DD} - 0.6			V
Digital Low-Level Output Voltage (V _{OL})	I _{LOAD} = 1mA	0		0.4	V
	I _{LOAD} = 10mA			0.5	V
SUPPLY CURRENT					
V _{DD} Current (Compounded)	Normal operation, V _{DD} = 3.3V		8.1	10.3	mA

Performance Specifications (continued)

(Note that production tests are performed at room temperature.)

PARAMETER	CONDITIONS	MIN	TYP	MAX	UNITS
CRYSTAL OSCILLATOR					
XIN to XOUT Capacitance	(Note 1)		3		pF
Capacitance to GND (Note 1)	XIN		5		pF
	XOUT		5		
INTERNAL RC OSCILLATOR					
Nominal Frequency			20.000		MHz
Accuracy	$V_{DD} = 3.0V, 3.6V; T_A = 22^\circ C$		± 1.5		%
RESET PIN					
Reset Pulse Fall Time	(Note 1)		1		μs
Reset Pulse Width	(Note 1)		5		μs
SPI SLAVE PORT (Figure 1)					
SCK Cycle Time (t_{SPICYC})		1			μs
Enable Lead Time ($t_{SPILEAD}$)		15			ns
Enable Lag Time (t_{SPILAG})		0			ns
SCK Pulse Width (t_{SPIW})	High	250			ns
	Low	250			
SSB to First SCK Fall (t_{SPISCK})	Ignore if SCK is low when SSB falls (Note 1)		2		ns
Disable Time (t_{SPIDIS})	(Note 1)		0		ns
SCK to Data Out (SDO) (t_{SPIEV})				25	ns
Data Input Setup Time (SDI) (t_{SPISU})		10			ns
Data Input Hold Time (SDI) (t_{SPIH})		5			ns
I²C SLAVE PORT (Figure 2, Note 1)					
Bus Idle (Free) Time Between Transmissions (STOP/START) (t_{BUF})		1500			ns
I ² C Input Fall Time (t_{ICF})	(Note 2)	20		300	ns
I ² C Input Rise Time (t_{ICR})	(Note 2)	20		300	ns
I ² C START or Repeated START Condition Hold Time (t_{STH})		500			ns
I ² C START or Repeated START Condition Setup Time (t_{STS})		600			ns
I ² C Clock High Time (t_{SCH})		600			ns
I ² C Clock Low Time (t_{SCL})		1300			ns
I ² C Serial Data Setup Time (t_{SDS})		100			ns
I ² C Serial Data Hold Time (t_{SDH})		10			ns
I ² C Valid Data Time (t_{VDA}): SCL Low to SDA Output Valid ACK Signal from SCL Low to SDA (Out) Low				900	ns

Note 1: Guaranteed by design, not subject to test.**Note 2:** Dependent on bus capacitance.

Timing Diagrams

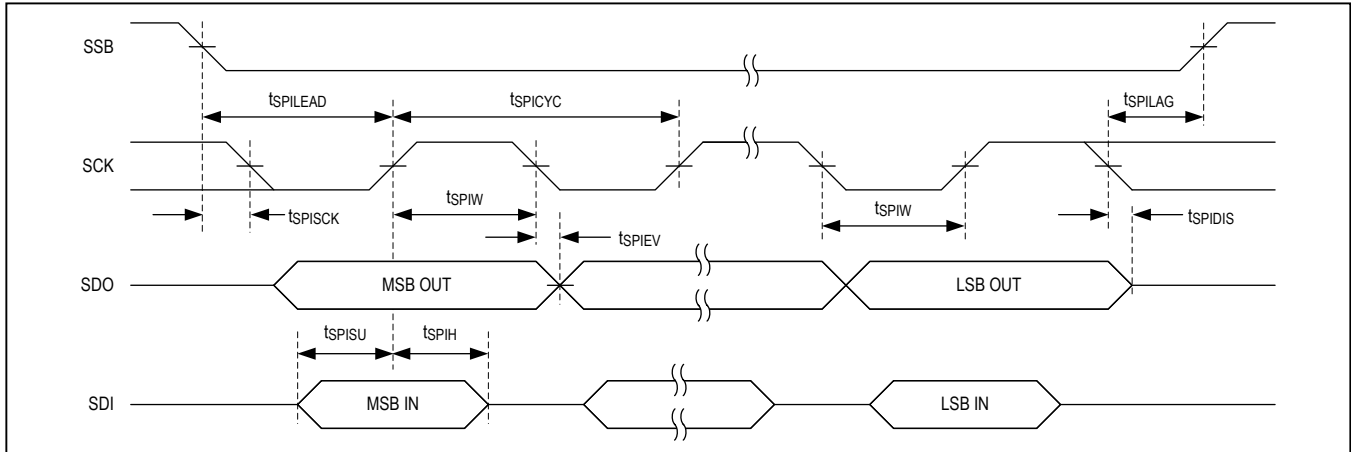

Figure 1. SPI Timing Diagram

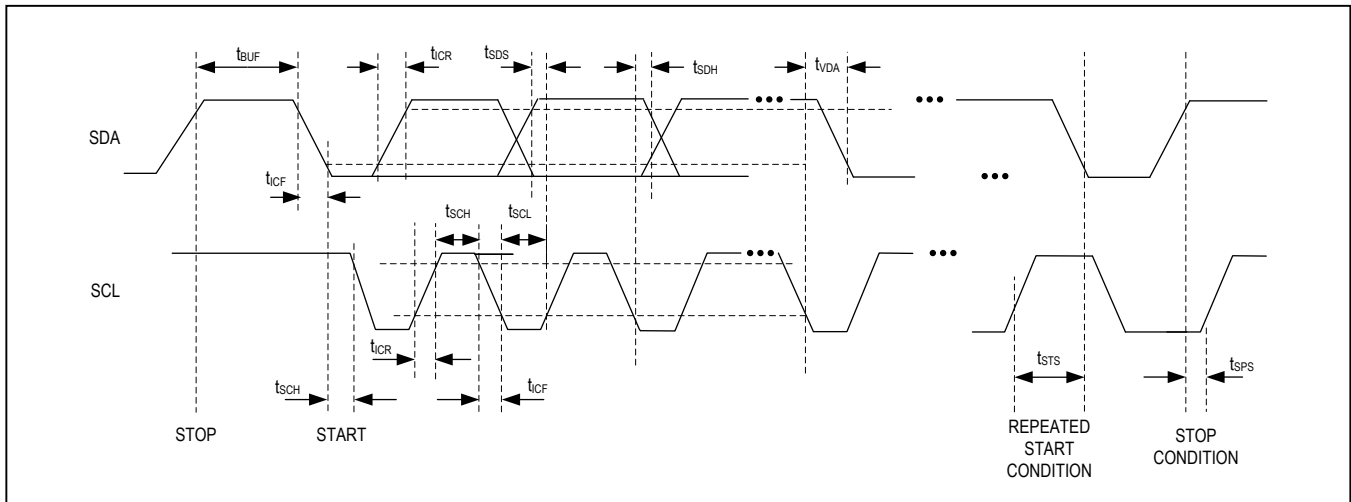
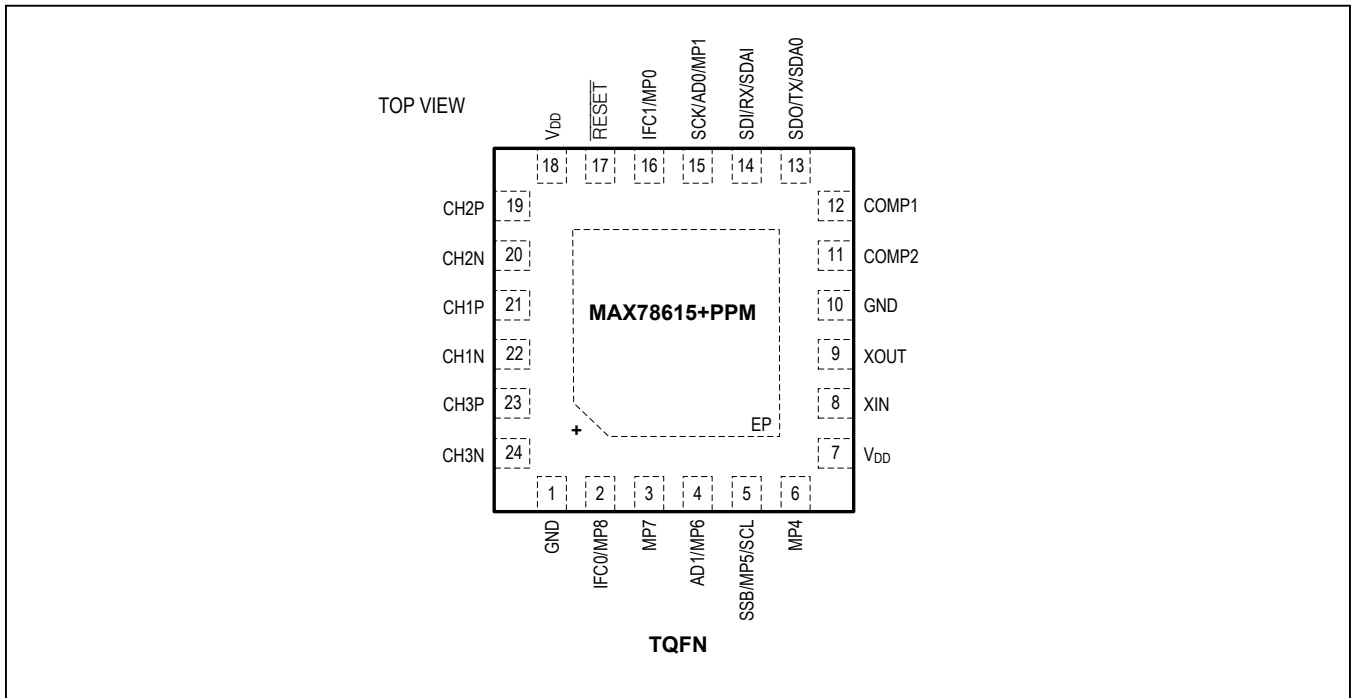

Figure 2. I²C Timing Diagram

Pin Configuration



Pin Description

PIN	NAME	FUNCTION
1, 10	GND	Ground
2	IFC0/MP8	IFC0 (Interface Selection)
3	MP7	Multipurpose DIO
4	AD1/MP6	Multipurpose DIO/Address
5	SSB/MP5/SCL	Slave Select (SPI)/MP5/I ² C Serial Clock
6	MP4	Multipurpose DIO
7, 18	V _{DD}	3.3V DC Supply
8	XIN	Crystal Oscillator Input
9	XOUT	Crystal Oscillator Output
10	GND	Ground
11	COMP2	Comparator 2 Input (Not Used/Reserved), No Connection
12	COMP1	Comparator 1 Input (Not Used/Reserved), No Connection
13	SDO/TX/SDAO	SPI Data Out/UART Tx/I ² C Data Out
14	SDI/RX/SDAI	SPI Data In/UART Rx/I ² C Data In

Pin Description (continued)

PIN	NAME	FUNCTION
15	SCK/AD0/MP1	SPI Clock/Address
16	IFC1/MP0	Multipurpose DIO/Interface Selection
17	$\overline{\text{RESET}}$	Active-Low Reset Input
19	CH2P	Pulse Transformer Interface Channel 2 (Negative)
20	CH2N	Pulse Transformer Interface Channel 2 (Positive)
21	CH1P	Pulse Transformer Interface Channel 1 (Negative)
22	CH1N	Pulse Transformer Interface Channel 1 (Positive)
23	CH3P	Pulse Transformer Interface Channel 3 (Negative)
24	CH3N	Pulse Transformer Interface Channel 3 (Positive)
—	EP	Exposed Pad. Internally connected to GND. Not intended as an electrical connection point.

Glossary

NAME	DESCRIPTION
AFE	Analog Front-End
ADC	Analog-to-Digital Converter
FSV	Peak System Voltage Required to Produce 250mVpk at the AFE ADC
FSI	Peak System Current Required to Produce 250mVpk at the AFE ADC
FSP	Full-Scale Power (FSI x FSV)
SPS	Sample Per Second
HPF	Highpass Filter

Block Diagram

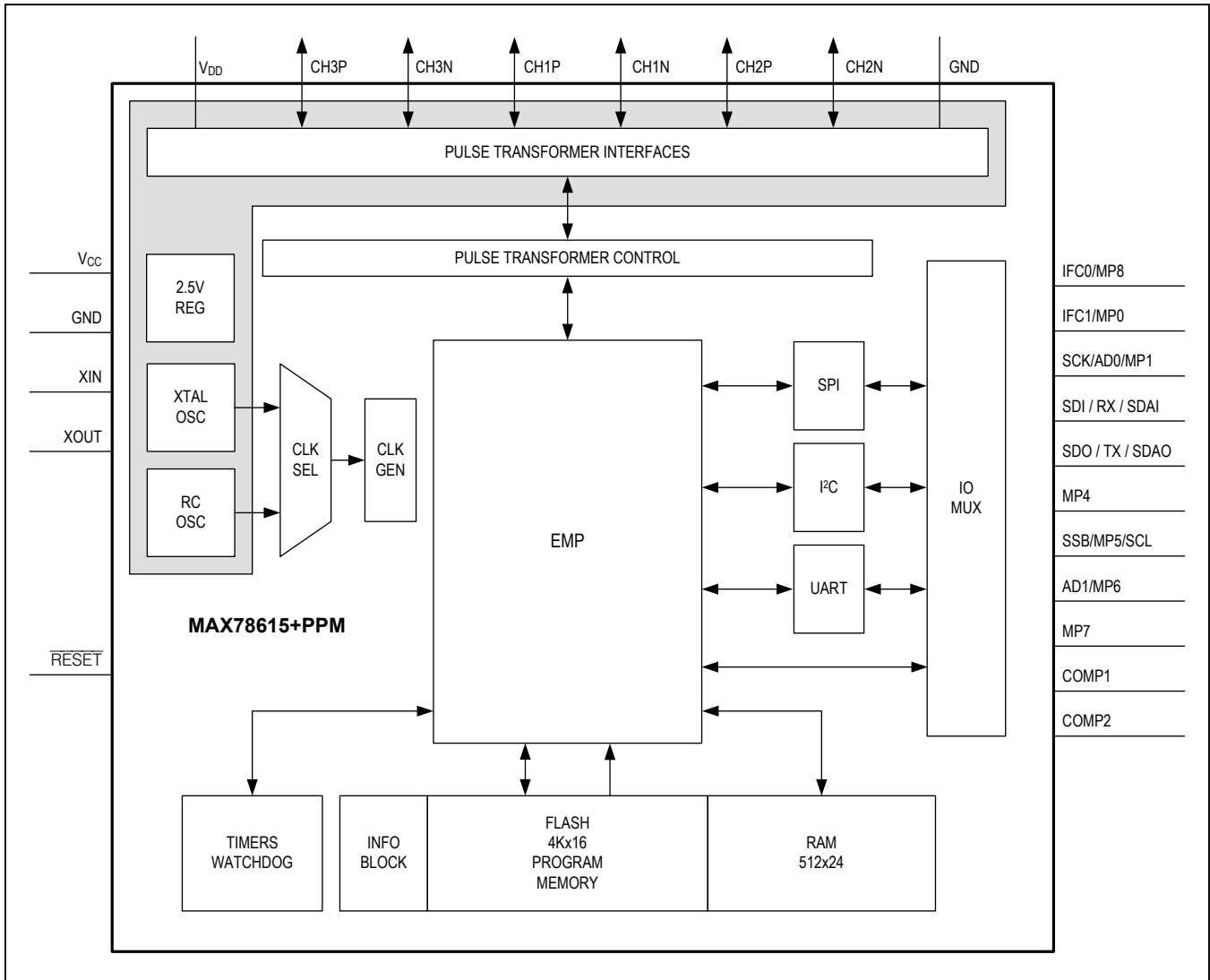

On-Chip Resources Overview

The MAX78615+PPM device integrates all the hardware blocks required for accurate AC power and energy measurement. Included on the device are the following:

- Oscillator and clock management logic
- Power-on reset, watchdog timer, and reset circuitry
- 24-bit measurement processor with RAM and flash memory
- UART, SPI, and I²C serial communication interfaces and multipurpose digital I/O
- Pulse transformer interfaces (for connection to up to three or more MAX78700 or MAX71071 devices)

Clock Management

The device can be clocked by oscillator circuitry that relies on an external crystal or, as a backup source, by a trimmed internal RC oscillator. The internal RC oscillator provides an accurate clock source for UART baud rate generation.

The chip hardware automatically handles the clock sources logic and distributes the clock to the rest of the device. Upon reset or power-on, the device will utilize the internal RC oscillator circuit for the first 1024 clock cycles, allowing the external crystal adequate time to startup. The device will then automatically select the external clock, if available. It will also automatically switch back to the internal oscillator in the event of a failure with the external oscillator. This condition is also monitored by the processor and available to the user in the STATUS register.

The MAX78615+PPM external clock circuitry requires a 20.000MHz crystal. The circuitry includes two 18pF ceramic capacitors. [Figure 3](#) shows the typical connection of the external crystal. This oscillator is self-biasing and therefore an external resistor should **not** be connected across the crystal.

An external 20MHz system clock signal can also be utilized instead of the crystal. In this case, the external clock should be connected to the XOUT pin while the XIN pin should be connected to GND.

Alternatively, if no external crystal or clock is utilized, the XOUT pin should be connected to GND and the XIN pin left unconnected.

Power-On Reset, Watchdog-Timer, and Reset Circuitry

Power-On Reset (POR)

An on-chip power-on reset (POR) block monitors the supply voltage (V_{DD}) and initializes the internal digital circuitry at power-on. Once V_{DD} is above the minimum operating threshold, the POR circuit triggers and initiates a reset sequence. It also issues a reset to the digital circuitry if the supply voltage falls below the minimum operating level.

Watchdog Timer (WDT)

A watchdog timer (WDT) block detects any software processing errors. The embedded software periodically refreshes the free-running watchdog timer to prevent it from timing out. If the WDT times out, it is an indication that software is no longer being executed in the intended sequence; thus, a system reset is initiated.

External Reset Pin ($\overline{\text{RESET}}$ Pin)

In addition to the internal sources, a reset can be forced by applying a low level to the $\overline{\text{RESET}}$ pin. If the $\overline{\text{RESET}}$ pin is pulled low, all digital activities in the device stop, except the clock management circuitry and oscillators, which continue to run. The external reset input is filtered to prevent spurious reset events in noisy environments. The reset does not occur until $\overline{\text{RESET}}$ has been held low for at least 1 μ s.

Once initiated, the reset mode persists until the $\overline{\text{RESET}}$ is set high and the reset timer times out (4096 clock cycles). At the completion of the reset sequence, the internal reset is released and the processor begins executing from address 0.

If not used, the $\overline{\text{RESET}}$ pin can be connected either directly or through a pullup resistor to V_{DD} supply. [Figure 4](#) shows simple connection diagram examples.

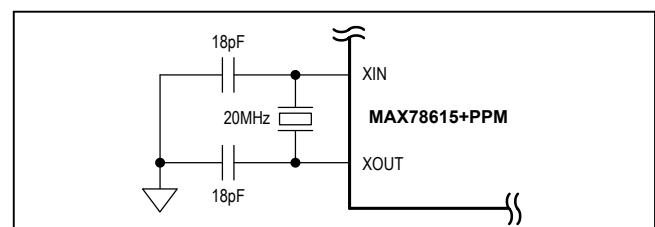

Figure 3. Typical Connection of External Crystal

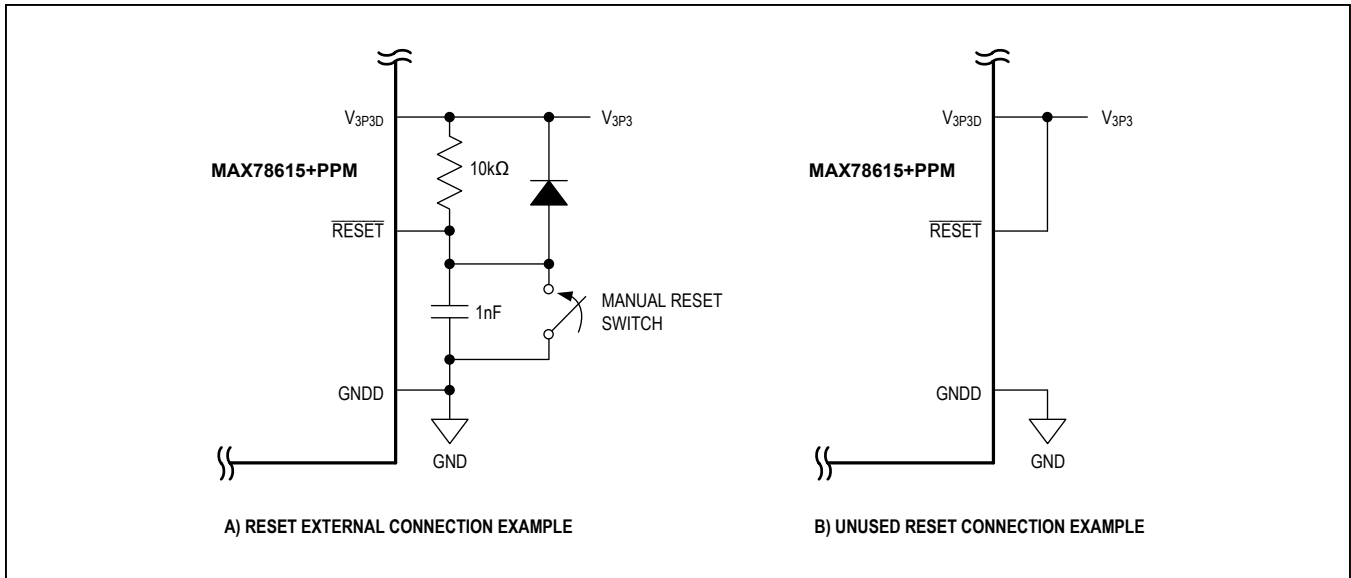

Figure 4. Connection Examples for \overline{RESET} Pin

24-Bit Measurement Processor

The MAX78615+PPM integrates a fixed-point 24-bit signal processor that performs all the digital signal processing necessary for energy measurement, alarm generation, calibration, compensation, etc. Functionality and operation of the device is determined by the firmware and described in the [Functional Description and Operation](#) section.

Flash and RAM

The MAX78615+PPM includes 8KB of on-chip flash memory. The flash memory contains program code and is used to store coefficients, calibration data, and configuration settings. The MAX78615+PPM includes 1.5KB of on-chip RAM, which contains the values of input and output registers and is utilized by the firmware for its operations.

Digital I/O Pins

There are a total of nine digital input/outputs on the MAX78615+PPM device. Some are dedicated to serial interface communications and configuration. Others are multi-purpose I/O (indicated as MP or “Multi-Purpose” pins) that can be used as a simple output under user control or routed to special purpose internal signals, such as alarm signaling.

Communication Interfaces

The MAX78615+PPM includes three communication interface options: UART, SPI, and I²C. Since the I/O pins are shared, only one mode is supported at a time. Interface configuration pins are sampled at power-on or reset to determine which interface is active.

Isolated Analog Front-End (AFE)

Up to three isolation interfaces (channels) are provided to provide power, configure/control, and read measurement data from a MAX78700 or MAX71071. The power is provided by the MAX78615+PPM, through dedicated pulses that are spaced at 10.00MHz/6 (600ns period), with write and read pulses located in between. The power pulses are also used to provide the synchronization for the MAX78700 (or MAX71071) on-chip PLL. Within every power pulse cycle a write data pulse and a read data pulse is inserted.

Data sent from the MAX78615+PPM to the isolated AFE:

- Power
- ADC Configuration
- Control

Data sent from the isolated AFE to the MAX78615+PPM:

- Voltage Samples
- Current Samples
- Die Temperature
- Bandgap and Trim Information

Functional Description and Operation

This section describes the MAX78615+PPM functionality. It includes measurements and relevant calculations, alarms, auxiliary functions such as calibrations, zero-crossing, etc.

A set of input (write), output (read), and read/write registers are provided to allow access to calculated data and alarms and to configure the device. The input (write) registers values can be saved into flash memory through a specific command. The values saved into flash memory are loaded in these registers at reset or power-on as defaults.

Signal Processing Description

AFE Configuration

The MAX78615+PPM supplies configuration and control to the isolated AFEs. The MAX71071 and MAX78700 have different configurations to support the same solution.

Input Mapping

Up to three remotes can be connected to the remote interfaces. The sensors are expected by the firmware to be connected to support the logical current/voltage mapping as shown in [Table 2](#).

Highpass Filters and Offset Removal

Offset registers for each analog input contain values to be subtracted from the raw ADC outputs for the purpose of removing inherent system DC offsets from any calculated power and RMS values. When the integrated highpass filter (HPF) is enabled, it dynamically updates the offset registers every accumulation interval. During each accumulation interval (or low-rate cycle), the HPF calculates the median or DC average of each input. Adjustable coefficients determine what portion of the measured offset is combined with the previous offset value (see [Table 3](#)).

The HPF_COEF_I and HPF_COEF_V registers contain signed fixed point numbers with a usable range of 0 to 1.0-LSB (negative values are not supported). Setting them to 1.0 (0x7FFFFFFF) causes the entire measured offset to be applied to the offset register enabling lump-sum offset removal. Setting them to zero disables any dynamic update of the offset registers by the HPF. The HPF coefficients apply to all three channels (current or voltage).

Table 1. Sample Rate and Preamplifier Settings

PARAMETER	MAX78700	MAX71071	NOTES
SPS	3306.9*	2381**	Samples per second
ADC PREAMP	1x	9x	—

*Sample rate per channel on multiplexed ADC.

**Sample rate per channel with one ADC per channel.

Table 2. Analog Input Assignment

REMOTE ANALOG INPUT PINS	REMOTE INTERFACE	INPUT NAME
INAP/N	CH1	Voltage 1 (AV1)
INBP/N		Current 1 (AI1)
INAP/N	CH2	Voltage 2 (AV2)
INBP/N		Current 2 (AI2)
INAP/N	CH3	Voltage 3 (AV3)
INBP/N		Current 3 (AI3)

Table 3. Offset Registers

REGISTER	DESCRIPTION
V1_OFFSETS	Voltage Input AV1 Offset Calibration
V2_OFFSETS	Voltage Input AV2 Offset Calibration
V3_OFFSETS	Voltage Input AV3 Offset Calibration
I1_OFFSETS	Current Input AI1 Offset Calibration
I2_OFFSETS	Current Input AI2 Offset Calibration
I3_OFFSETS	Current Input AI3 Offset Calibration

Table 4. Highpass Filter Coefficients

REGISTER	DESCRIPTION
HPF_COEF_I	HPF Coefficient for AIA, AIB, and AIC Current Inputs
HPF_COEF_V	HPF Coefficient for AVA, AVB, and AVC Voltage Inputs

Gain Correction

The system (sensors) and the MAX78615+PPM device inherently have gain errors that can be corrected by using the gain registers. These registers can be directly accessed and modified by an external host processor or automatically updated by an integrated self-calibration routine.

Input gain registers are signed fixed-point numbers with the binary point to the left of bit 21. They are set to 1.0 by default and have a usable range of 0 to 4.0-LSB (negative values are not supported). The gain equation for each input X can be described as $Y = gain * X$.

Die Temperature Compensation

The MAX78615+PPM receives the isolated ADC (MAX78700 or MAX71071) die temperature measurements. This data is used by the signal processor for correcting the voltage reference error (bandgap curvature). It is also available to the user in the TEMPC registers. Temperature data has a fixed scaling with a range of -16384°C to +16384°C less one LSB (format S.10). See [Table 6](#).

Setting the temperature compensation (TC) bit in the Control register allows the firmware to further adjust the system gain based on measured isolated die temperature. The isolated ADC die temperature offset is typically calibrated by the user during the calibration stage. Die temperature gain is set to a factory default value for most applications, but can be adjusted by the user. See [Table 7](#).

Table 5. Voltage and Current Gain Registers

REGISTER	DESCRIPTION
V1_GAIN	Voltage Input AV1 Gain Calibration
V2_GAIN	Voltage Input AV2 Gain Calibration
V3_GAIN	Voltage Input AV3 Gain Calibration
I1_GAIN	Current Input AI1 Gain Calibration
I2_GAIN	Current Input AI2 Gain Calibration
I3_GAIN	Current Input AI3 Gain Calibration

Table 6. Remote ADC Die Temperature Registers

REGISTER	DESCRIPTION	LSB	TIME SCALE
TEMPC1	Chip Temperature (Celsius°) Channel 1	°C/2 ¹⁰	1 interval
TEMPC2	Chip Temperature (Celsius°) Channel 2	°C/2 ¹⁰	
TEMPC3	Chip Temperature (Celsius°) Channel 3	°C/2 ¹⁰	

Phase Compensation

Phase compensation registers are used to compensate for phase errors or time delays between the voltage input source and respective current source that are introduced by the off-chip sensor circuit. The user configurable registers are signed fixed point numbers with the binary point to the left of bit 21. Values are in units of high rate sample delays so each integer unit of delay is 1/SPS with a total possible delay of ±4 samples. See [Table 8](#).

Example:

To compensate a phase error of 315µs (or 6.8° at 60Hz) for a MAX78700 isolated AFE it is necessary to set the relevant phase compensation register as follows:

$$Compensation = \frac{Phase\ Error}{Sample\ Rate} = \frac{315\ E^{-6}}{3174.6}$$

$$Compensation = 1.0000$$

The value to enter in the phase compensation register is therefore:

$$PHASECOMP = \frac{315\ E^{-6}}{3174.6} \times 2^{21} = 2097150 = 0x1FFFFD$$

Table 7. Remote ADC Temperature Calibration Registers

REGISTER	DESCRIPTION
T_OFFS1, TOFFS2, TOFFS3	Die Temperature Offset Calibration.
T_GAIN	Die Temperature Slope Calibration, set by factory.

Table 8. Phase Compensation Registers

REGISTER	LSB	DESCRIPTION
PHASECOMP1	SAMPLE/2 ²¹	Phase (delay) compensation for AI1 relative to AV1
PHASECOMP2	SAMPLE/2 ²¹	Phase (delay) compensation for AI2 relative to AV1
PHASECOMP3	SAMPLE/2 ²¹	Phase (delay) compensation for AI3 relative to AV1

Voltage Input Configuration

The device supports multiple analog input configurations for determining the voltages in a three-phase system. The CONFIG register is used to instruct the device on how to compute them. See [Table 9](#).

The VDELTA bit must be set whenever the voltage sensors measure phase voltages (line-to-neutral), but the load is connected in a Delta configuration. The MAX78615+PPM then computes line-to-line voltages from the inputs and uses those for all other computations.

The VPHASE setting determines how many voltage sensors are present, and in which phases. If three sensors are used, these bits should be set to zero. If two sensors are used, settings 01, 10 and 11 indicate the phase with no

voltage sensor. This phase will then be computed such that $VA+VB+VC$ equals to zero. Note that using two voltage sensors is not recommended in Wye-connected systems, as the previous equation may not necessarily be true.

The INV_AVx bits instruct the MAX78615+PPM to invert every sample of the corresponding voltage input, before performing any other computations based on the VDELTA and VPHASE settings. See [Table 10](#).

Voltage Input Flowchart

[Figure 5](#) illustrates the computational flowchart for VA, VB, and VC. The values for the voltage input configuration register can be saved in flash memory and automatically restored at power-on or reset.

Table 9. Voltage Inputs Configuration

CONFIG BITS	NAME	FUNCTION
22	INV_AV3	Invert voltage samples AV3
21	INV_AV2	Invert voltage samples AV2
20	INV_AV1	Invert voltage samples AV1
5	VDELTA	Compute and report line-to-line voltages
4:3	VPHASE	Missing sensor on voltage input or reference

Table 10. Voltage Inputs Computation

VDELTA	VPHASE	VA	VB	VC
0	00	AV1	AV2	AV3
0	01	AV3-AV2	AV2	AV3
0	10	AV1	AV1-AV3	AV3
0	11	AV1	AV2	AV2-AV1
1	00	AV3-AV1	AV1-AV2	AV2-AV3
1	01	AV2-AV3	AV2-AV1	AV3-AV1
1	10	AV1-AV2	AV1-AV3	AV3-AV2
1	11	AV1-AV3	AV2-AV3	AV1-AV2

Note: INV_AVx settings are applied before these computations.

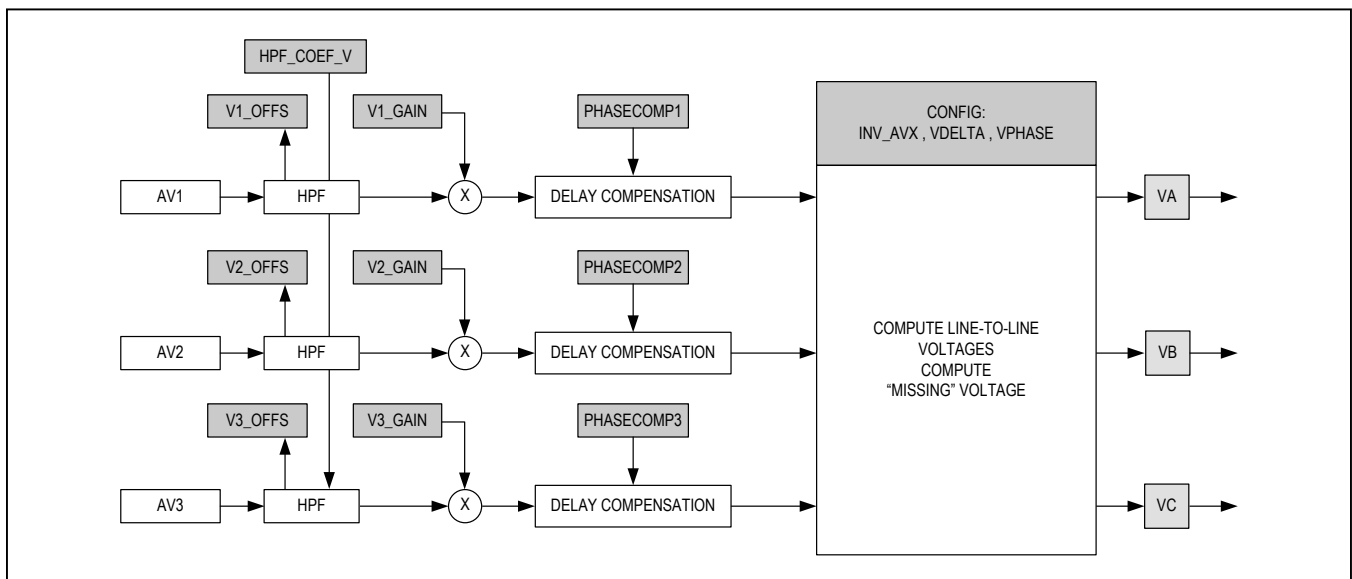

Figure 5. Computational Flowchart for VA, VB, and VC

Current Input Configuration

The MAX78615+PPM supports multiple analog input configurations for determining the currents in a three-phase system. The CONFIG register is used to instruct the MAX78615+PPM how to compute them. See [Table 11](#).

The IPHASE setting determines how many line current sensors are present, and for which phases. If three sensors are used, these bits should be set to zero. If two sensors are used, settings 01, 10, and 11 indicate the phase without a line current sensor. The current for this phase will then be computed according to the INEUTRAL and VDELTA settings. If VDELTA is cleared and IN can be assumed to be zero, the current is computed such that $IA + IB + IC = 0$. If VDELTA is set, the current in this phase is

the difference between the two other currents (INEUTRAL must be cleared in these two cases).

When the INEUTRAL bit is set, a sensor in the neutral conductor replaces one of the three line current sensors. IN is directly measured from a sensor placed in the neutral conductor and the firmware calculates the current for the input with no line current sensor, such that $IA + IB + IC = IN$ (IPHASE cannot be 00). See [Table 12](#).

Current Input Flowchart

[Figure 6](#) illustrates the computational flowchart for IA, IB, and IC. The values for current input configuration register can be saved in flash memory and automatically restored at power-on or reset.

Table 11. Current Inputs Configuration

CONFIG BITS	NAME	FUNCTION
2	INEUTRAL	Configuration uses a current sensor in the neutral conductor. This sensor replaces the missing sensor (see IPHASE setting).
1:0	IPHASE	Missing sensor on current input 00: none missing 01: AI1 10: AI2 11: AI3

Table 12. Current Inputs Computation

INEUTRAL	IPHASE	VDELTA	IA	IB	IC
x	00	x	AI1	AI2	AI3
0	01	0	$-(AI2+AI3)$	AI2	AI3
0	10	0	AI1	$-(IA1+AI3)$	AI3
0	11	0	AI1	AI2	$-(IA1+AI2)$
0	01	1	$AI2-IA3$	AI2	AI3
0	10	1	AI1	$AI3-IA1$	AI3
0	11	1	AI1	AI2	$AI1-IA2$
1	01	x	$AI1-(AI2+AI3)$	AI2	AI3
1	10	x	AI1	$AI2-(AI1+AI3)$	AI3
1	11	x	AI1	AI2	$AI3-(AI1+AI2)$

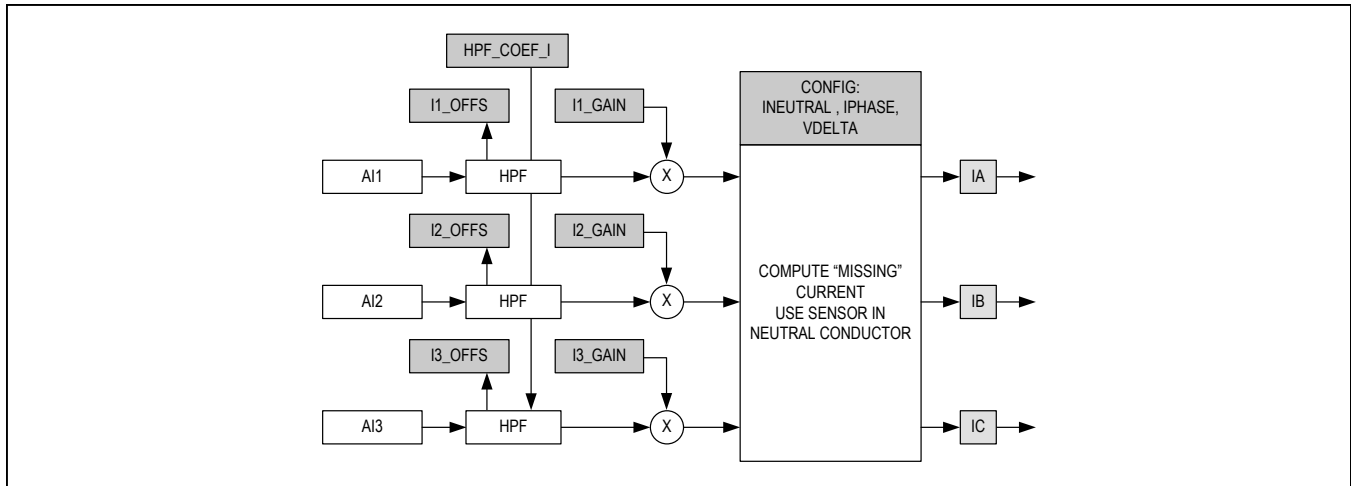

Figure 6. Computational Flowchart for IA, IB, and IC

Data Refresh Rates

Instantaneous voltage and current measurement results are updated at the sample rate (SPS) and are generally not useful unless accessed with a high-speed interface such as SPI. The CYCLE register is a 24-bit counter that increments every high-rate sample update and resets when low rate results are updated.

Low rate results, updated at a user-configurable rate (also referred to as accumulation interval), are typically used and more suitable for most applications. The FRAME register is a counter that increments every accumulation interval. A data ready indicator in the STATUS register indicates when new data is available. Optionally, this indicator can be made available as a signal on one of the maskable MP output pins.

The high rate samples in one accumulation interval are averaged to produce a low-rate result, increasing their accuracy and repeatability. Low rate results include RMS voltages and currents, frequency, power, energy, and power factor. The accumulation interval can be based on a fixed number of ADC samples or locked to the incoming line voltage cycles.

If Line Lock is disabled, the accumulation interval defaults to a fixed time interval defined by the number of samples defined in the SAMPLES register (default of SPS samples or 1.0 seconds).

When the Line-Lock bit (LL) is set, and a valid AC voltage signal is present, the actual accumulation interval is stretched to the next positive zero-crossing of the reference line voltage after the defined number of samples has been reached. If there is not a valid AC signal present and line lock is enabled, there is a 100 sample timeout

implemented that would limit the accumulation interval to SAMPLES+100.

The DIVISOR register records the actual duration (number of high rate samples) of the last low-rate interval whether or not Line-Lock is enabled.

Zero-crossing detection and line frequency for the purpose of determining the accumulation interval are derived from a composite signal, $VZC = VA - 0.5 \times VB - 0.25 \times VC$. For a three-phase system, this signal oscillates at the line frequency as long as any of the three voltages is present.

Calibration

The firmware provides integrated calibration routines to modify gain and offset coefficients. The user can setup and initiate a calibration routine through the Command Register. On a successful calibration, the command bits are cleared in the Command Register, leaving only the system setup bits. In case of a failed calibration, the bit in the Command Register corresponding to the failed calibration is left set. When calibrating, the line-lock bit should be set for best results.

The calibration routines will write the new coefficients to the relevant registers. The user can then save the new coefficients into flash memory as defaults using the flash access command in the Command Register.

See the [Command Register](#) section for more information on using commands.

Voltage and Current Gain Calibration

In order to calibrate the gain parameters for voltage and current channels, a reference AC signal must be applied to the channel to be calibrated. The RMS value corre-

sponding to the applied reference signal must be entered in the relevant target register (V_TARGET, I_TARGET). Considering calibration is done with low rate RMS results, the value of the target register should never be set to a value above 70.7% of full scale.

Initially, the value of the gain is set to unity for the selected channels. RMS values are then calculated on all inputs and averaged over the number of measurement cycles set by the CALCYCS register. The new gain is calculated by dividing the appropriate Target register value by the averaged measured value. The new gain is then written to the select Gain registers unless an error occurred.

Note that there is only one V_TARGET register for voltages. It is possible to calibrate multiple or all voltage channels simultaneously, if and only if the same RMS voltage value is applied to each corresponding input. Analogous considerations apply to the current channels, which are calibrated via the I_TARGET register.

Offset Calibration

If the highpass filters are not desired then the user can fix the DC offset compensation registers through calibration. To calibrate offset, all signals should be removed from all analog inputs although it is possible to do the calibration in the presence of AC signals. In the command, the user also specifies which channel(s) to calibrate. Target registers are not used for offset calibration.

During the calibration process, each input is accumulated over the entire calibration interval as specified by the CALCYCS register. The result is divided by the total number of samples and written to the appropriate offset register, if selected in the calibration command. Using the offset calibration command sets the respective HPF coefficients to zero, thereby fixing the offset registers to their calibrated values.

Die Temperature Calibration

To re-calibrate the on-chip temperature sensor offset, the user must first write the known chip temperature to the T_TARGET register. Next, the user initiates the Temperature Calibration Command in the Command Register. This will update the T_OFFS offset parameter with a new offset based on the known temperature supplied by the user. The T_GAIN gain register is set by the factory and not updated with this routine.

Voltage Channel Measurements

Instantaneous voltage measurements are updated every sample, while RMS voltages are updated every accumulation interval (n samples). See [Table 13](#).

The MAX78615+PPM reports true RMS measurements for each input. An RMS value is obtained by performing the sum of the squares of instantaneous values over a time interval (accumulation interval) and then performing a square root of the result after dividing by the number of samples in the interval. See [Figure 7](#).

Table 13. Voltage Channels Registers

REGISTER	DESCRIPTION	LSB	TIME SCALE
VA VB VC	Instantaneous voltage at time t	FSV/2 ²³	1 sample
VA_RMS VB_RMS VC_RMS	RMS voltage of last interval	FSV/2 ²³	1 interval
VT_RMS	Average of VA_RMS, VB_RMS, VC_RMS	FSV/2 ²³	

Note that the VDELTA and VPHASE settings in the CONFIG register affect how the instantaneous and averaged values are computed as described in the Voltage Input Configuration section.

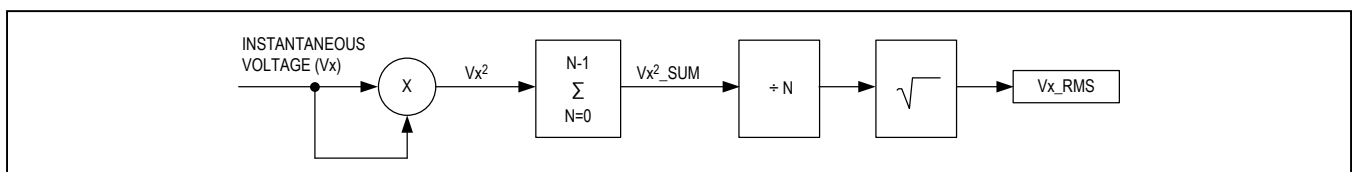

Figure 7. True RMS Value

Line Frequency

This output is a measurement of the fundamental frequency of the AC voltage source. It is derived from a composite signal and therefore applies to all three phases (it is a single reading per device) and is updated every 64 line cycles. Frequency data is reported as binary fixed-point number, with a range of 0 to +256Hz less one LSB (format S.16). See [Table 14](#).

Current Channel Measurements

Instantaneous current measurements are updated every sample, while peak currents and RMS currents are updated every accumulation interval (n samples). See [Table 15](#).

Note that the INEUTRAL and IPHASE settings in the CONFIG register affect how the instantaneous and averaged values are computed as described in the [Current Input Configuration](#) section.

Peak Current

This output is a capture of the largest magnitude instantaneous current load sample. See [Figure 8](#).

RMS Current

The MAX78615+PPM reports true RMS measurements for current inputs. The RMS current is obtained by performing the sum of the squares of the instantaneous voltage samples over the accumulation interval and then performing a square root of the result after dividing by the number of samples in the interval. See [Figure 9](#).

An optional “RMS offset” for the current channels can be adjusted to reduce errors due to noise or system offsets (crosstalk) exhibited at low input amplitudes. Full-scale values in the IxRMS_OFFS registers are squared and subtracted from the accumulated/divided squares. If the resulting RMS value is negative, zero is used.

Table 14. Frequency Measurement Register

REGISTER	DESCRIPTION	LSB	TIME SCALE
FREQ	AC Voltage Frequency	Hz/2 ¹⁶	64 voltage line cycles

Table 15. Current Channels Register

REGISTER	DESCRIPTION	LSB	TIME SCALE
IA IB IC	Instantaneous Current	FSI/2 ²³	1 sample
IA_PEAK IB_PEAK IC_PEAK	Peak Current	FSI/2 ²³	1 interval
IA_RMS IB_RMS IC_RMS	RMS Current	FSI/2 ²³	
IT_RMS	Average of IA_RMS, IB_RMS, IC_RMS	FSI/2 ²³	

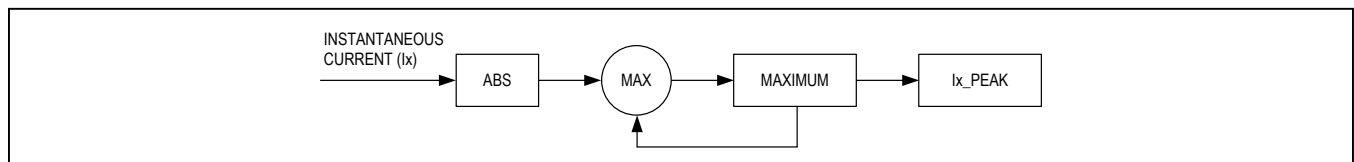

Figure 8. Peak Current Value

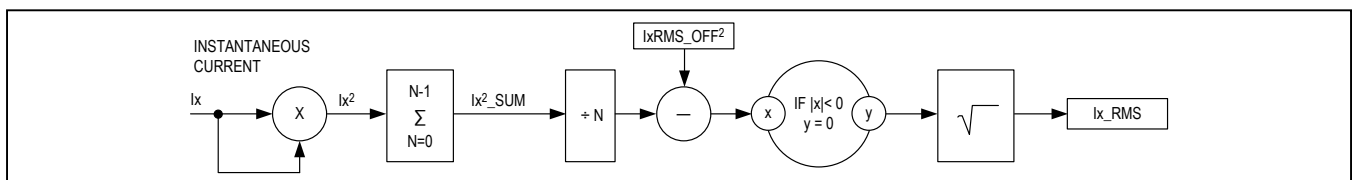

Figure 9. True Current Input Value

Current and Voltage Imbalance

Imbalance of a three-phase system is typically defined as the percentage of the maximum deviation of any of the phases from the average of the phases.

Voltage imbalance is obtained from Vx_RMS and VT_RMS as

$$VIMBAL \% = \frac{\max(|VARMS - VTRMS|, |VBRMS - VTRMS|, |VCRMS - VTRMS|)}{VTRMS} \times 100$$

Current imbalance is obtained from Ix_RMS and IT_RMS as

$$IIMBAL \% = \frac{\max(|IARMS - ITRMS|, |IBRMS - ITRMS|, |ICRMS - ITRMS|)}{ITRMS} \times 100$$

The MAX78615+PPM monitors the deviation of any phase from the average value. It generates an alarm if the deviation exceeds user programmable threshold; V_IMB_MAX for voltages and I_IMB_MAX for currents.

The thresholds are expressed as binary full-scale units with a value range of 0.0 to 1.0 less one LSB (S.23 format). 1.0 thus corresponds to 100% imbalance.

Example: generate an alarm if voltage imbalance exceeds 1.5%.

$$V_{IMB_{MAX}} = \text{int}\left(\frac{1.5}{100} \times 2^{23}\right) = 125.829 = 0x1E8b5$$

Power Calculations

This section describes the detailed flow of power calculations in the MAX78615+PPM. Table 16 lists the available measurement results for AC power.

Active Power (P)

The instantaneous power results (PA, PB, PC) are obtained by multiplying aligned instantaneous voltage and current samples. The sum of these results are then averaged over N samples (accumulation time) to compute the average active power (WATT_A, WATT_B, WATT_C). See Figure 10.

The value in the Px_OFFS register is the “Power Offset” for the power calculations. Full-scale values in the Px_OFFS register are subtracted from the magnitude of the averaged active power. If the resulting active power value results in a sign change, zero watts are reported.

Table 16. Power and Power Factor Registers

REGISTER	DESCRIPTION	LSB	TIME SCALE
WATT_A WATT_B WATT_C	Average Active Power (P)	FSP/2 ²³	1 interval
VAR_A VAR_B VAR_C	Average Reactive Power (Q)	FSP/2 ²³	
VA_A VA_B VA_C	Apparent Power (S)	FSP/2 ²³	
PF_A PF_B PF_C	Power Factor	FSP/2 ²³	
WATT_T	Average of WATT_A, WATT_B, WATT_C	FSP/2 ²³	
VAR_T	Average of VAR_A, VAR_B, VAR_C	FSP/2 ²³	
VA_T	Average of VA_A, VA_B, VA_C	FSP/2 ²³	
PF_T	Total power factor: Equal to WATT_T / VA_T	FSP/2 ²³	

Note that the voltage and current configuration settings in the CONFIG register affect the physical meaning of the computed power results.

Reactive Power (Q)

Instantaneous reactive power results are calculated by taking the square root of the Apparent Power squared minus the Active Power squared to produce the Reactive Power (VAR_A, VAR_B, VAR_C). A reactive power offset (Qx_OFFS) is also provided for each channel. See [Figure 11](#).

Apparent Power (S)

The apparent power, also referred as Volt-Amps, is the product of low-rate RMS voltage and current results. Offsets applied to RMS current will affect apparent power results.

Power Factor (PF)

The power factor registers capture the ratio of active power to apparent power for the most recent accumulation interval. The sign of power factor is determined by the sign of active power. Power factors are reported as a binary fixed-point number, with a range of -2 to +2 less one LSB (format S.22).

$$PF_x = \frac{WATT_x}{VA_x}$$

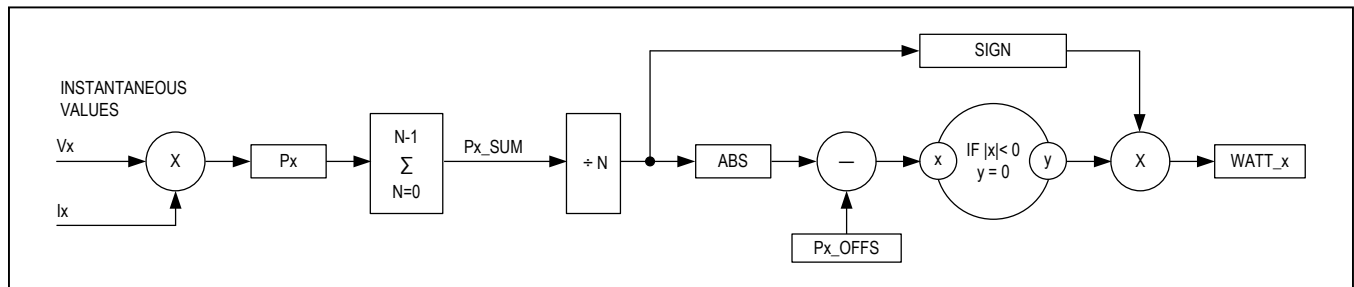

Figure 10. Active Power (P) Value

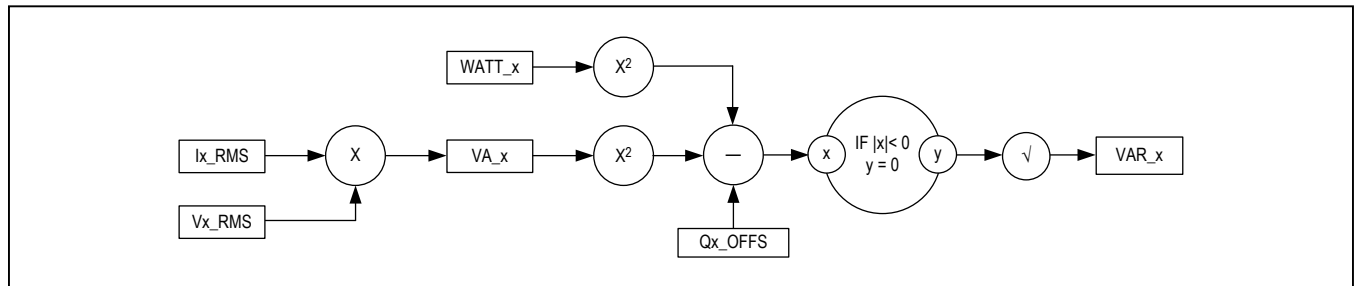

Figure 11. Reactive Power (Q) Value

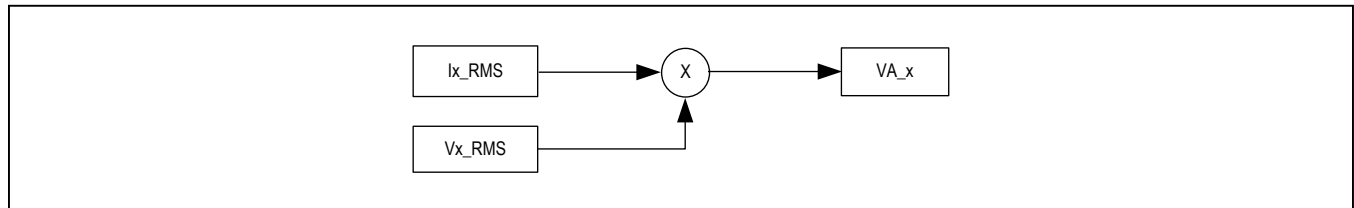

Figure 12. Apparent Power (S) Value

Totals of Active Power, Reactive Power, Apparent Power, and Power Factor

The total power results in a three-phase system depend on how the AC source, the load, and the sensors are configured. For example, in Wye-connected systems, the totals are computed as the sum of all three per-phase results. In many Delta configurations, the total power is the sum of two per-phase results only, and the third per-phase result must be ignored. The firmware requires a setting to indicate how the totals are to be computed. The PPHASE bits in the CONFIG register serve this purpose. See [Table 17](#).

When PPHASE is not 00, the firmware computes the totals of two phases only, as is typically done when only line currents are available in a Delta-connected load. In such cases, the total apparent power is correctly scaled by a factor of $\sqrt{3}/2$. In order to prevent overflows, all totals are computed as averages and must be multiplied by two by the host. When PPHASE is equal to 00, all totals are computed as averages and must be multiplied by three by the host. See [Table 18](#).

The total power factor is computed as

$$PF_T = \frac{WATT_T}{VA_T}$$

Fundamental Calculations

The MAX78615+PPM solution includes the ability to filter low rate voltage, current, active power, and reactive power measurement results into fundamental components. These outputs can be used to track individual harmonic contents for the measurements. See [Table 19](#).

The HARM register is used to select the single Nth harmonic of the line voltage fundamental frequency to extract. This input register is set by default to N = 0x000001 selecting the first harmonic (also known as the fundamental frequency). This setting provides the user with fundamental frequency component of the measurements. By setting the value in the HARM register to a higher harmonic, the fundamental result registers will contain measurement results of the selected harmonic at $FREQ \times HARM$.

Table 17. Phase Selection for Power Computation

CONFIG BITS	NAME	FUNCTION
7:6	PPHASE	Ignore phase for total power computations 00: none 01: phase A 10: phase B 11: phase C

Table 18. Selection of Power Calculation Equations

PPHASE	TOTAL ACTIVE POWER	TOTAL REACTIVE POWER	TOTAL APPARENT POWER
	WATT_T =	VAR_T =	VA_T =
00	$\frac{(WATT_A + WATT_B + WATT_C)}{3}$	$\frac{(VAR_A + VAR_B + VAR_C)}{3}$	$\frac{(VA_A + VA_B + VA_C)}{3}$
01	$\frac{(WATT_B + WATT_C)}{2}$	$\frac{(VAR_B + VAR_C)}{2}$	$\frac{\sqrt{3}}{2} \times \frac{(VA_B + VA_C)}{2}$
10	$\frac{(WATT_A + WATT_C)}{2}$	$\frac{(VAR_A + VAR_C)}{2}$	$\frac{\sqrt{3}}{2} \times \frac{(VA_A + VA_C)}{2}$
11	$\frac{(WATT_A + WATT_B)}{2}$	$\frac{(VAR_A + VAR_B)}{2}$	$\frac{\sqrt{3}}{2} \times \frac{(VA_A + VA_B)}{2}$

Energy Calculations

Energy calculations are included in the MAX78615+PPM to minimize the traffic on the host interface and simplify system design. Low rate power measurement results are multiplied by the number of samples (register DIVISOR) to calculate the energy in the last accumulation interval. Energy results are summed together until a user defined “bucket size” is reached. For every bucket of energy is reached, the value in the energy counter register is incremented by one.

All energy counter registers are low-rate 24-bit output registers that contain values calculated over multiple accumulation intervals. Both import (positive) and export

(negative) results are provided for active and reactive energy. See [Table 20](#).

Energy results are cleared upon any power-down or reset and can be manually cleared by the external host using the Energy Clear command (0xECxxxx).

Bucket Size for Energy Counters

The BUCKET register allows the user to define the unit of measure for the energy counter registers. BUCKET is an unsigned 48-bit fixed-point number with 24 bits for the integer part (BUCKETH = U.0) and 24 bits for the fractional part (BUCKETL = U.24). The bucket value can be saved to flash memory as the register default. BUCKETH must be set to nonzero to ensure proper energy counting. See [Table 21](#).

Table 19. Results Registers for Single Harmonic

REGISTER	DESCRIPTION	LSB	TIME SCALE
VFUND_A VFUND_B VFUND_C	Voltage content at specified harmonic	FSP/2 ²³	1 interval
IFUND_A IFUND_B IFUND_C	Current content at specified harmonic	FSP/2 ²³	
PFUND_A PFUND_B PFUND_C	Active power content at specified harmonic	FSP/2 ²³	
QFUND_A QFUND_B QFUND_C	Reactive power content at specified harmonic	FSP/2 ²³	

Table 20. Energy Counter Registers

REGISTER	LSB	DESCRIPTION
WHA_POS WHB_POS WHC_POS	$\frac{\text{BUCKET} \times \text{FSV} \times \text{FSI}}{\text{SPS}} \text{ watt-sec}$	Positive Active Energy Counter, per phase
WHA_NEG WHB_NEG WHC_NEG		Negative Active Energy Counter, per phase
VARHA_POS VARHB_POS VARHC_POS		Positive Reactive Energy Counter, per phase
VARHA_NEG VARHB_NEG VARHC_NEG		Negative Reactive Energy Counter, per phase

Example: 1Watt-hr bucket with a MAX78700

In this example, the full scale is assumed to be set as follows:

FSV = 667V; FSI = 62A

$$\text{BUCKET} = \frac{\text{Watthours(Wh) per count} \times 3600 \text{ sec / hr} \times \text{SPS}}{\text{FSV} \times \text{FSI}}$$

In order to set the energy bucket to 1Wh:

$$\text{BUCKET} = \frac{1 \times 3600 \times 3174.6}{667 \times 62} = 276.3592$$

Therefore, the bucket register(s) value should be set as follows:

$$\text{BUCKET} = \text{BUCKETH} + \text{BUCKETL}/2^{24}$$

$$\text{BUCKETH} = \text{INT}(\text{BUCKET})$$

$$\text{BUCKETL} = (\text{BUCKET} - \text{INT}(\text{BUCKET})) \times 2^{24}$$

$$\text{BUCKETH} = 276 = 0x000114$$

$$\text{BUCKETL} = 0.3592 = 0x5BF722$$

Min/Max Tracking

The MAX78615+PPM provides a set of output registers for tracking the minimum and/or maximum values of up to eight (8) different low-rate measurement results over multiple accumulation intervals. The user can select which measurements to track through an address table. The values in MM_ADDR# are word addresses for all host interfaces and can be saved to flash memory by the user as the register defaults. Results are stored in RAM and cleared upon any power-down or reset and can be cleared by the host using the RTRK bit in the COMMAND register. See [Table 22](#).

Table 21. BUCKET Register Bitmap

NAME	BUCKET													
	BUCKETH							BUCKETL						
Description	High word							Low word						
Bit Position	23	22	...	2	1	0	23	22	21	...	2	1	0	
Value	2 ²³	2 ²²	...	2 ²	2 ¹	2 ⁰	2 ⁻¹	2 ⁻²	2 ⁻³	...	2 ⁻²²	2 ⁻²³	2 ⁻²⁴	

Table 22. Min/Max Tracking Function Registers

REGISTER	DESCRIPTION	TIME SCALE
MM_ADDR0	Word addresses to track minimum and maximum values. A value of zero disables tracking for that address slot.	—
MM_ADDR1		
MM_ADDR2		
MM_ADDR3		
MM_ADDR4		
MM_ADDR5		
MM_ADDR6		
MM_ADDR7		
MIN0	Minimum low rate value at MM_ADDR#.	Multiple intervals
MIN1		
MIN2		
MIN3		
MIN4		
MIN5		
MIN6		
MIN7		

Table 22. Min/Max Tracking Function Registers (continued)

REGISTER	DESCRIPTION	TIME SCALE
MAX0	Maximum low rate value at MM_ADDR#.	Multiple intervals
MAX1		
MAX2		
MAX3		
MAX4		
MAX5		
MAX6		
MAX7		

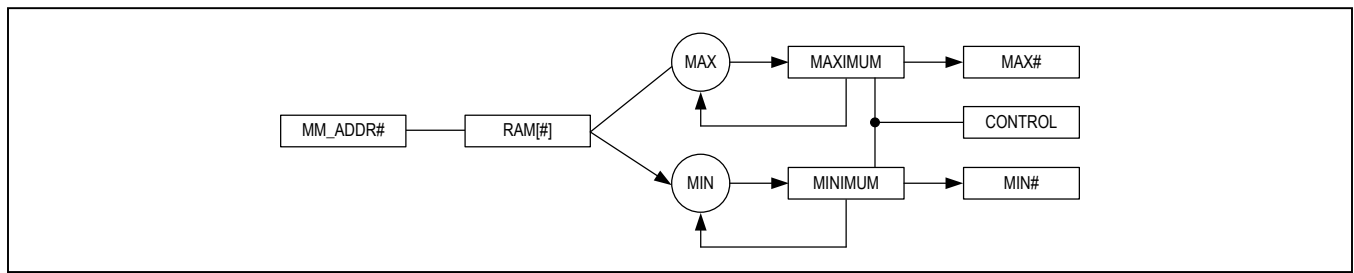

Figure 13. Min/Max Tracking

Voltage Sag Detection

The MAX78615+PPM implements a voltage sag detection function for each of the three phases. When a phase voltage drops below a programmable threshold, a corresponding alarm is generated. The firmware computes the following indicator to detect whether the voltage falls below the threshold.

$$V_{SAGX} = \sum_{n=0}^{VSAG_INT-1} (v_{Xn}^2 - VSAG_LIM^2)$$

where:

- VSAG_LIM is the user-settable RMS value of the voltage threshold.
- VSAG_INT is the user-settable number of high-rate samples over which the indicators should be computed. For optimal performance, this should be set so that the resulting interval is an integer multiple of the line period (at least one half line period)
- X is the phase (A, B, C).

If VSAGX becomes negative, the firmware sets the VX_SAG bit for the corresponding phase in the STATUS register. If VX_SAG is enabled in a MASK register, the

corresponding pin is also be asserted low. If the VX_SAG bit is set in the STICKY register, then the alarm bit will remain set and any unmasked AL pin will remain low until the VX_SAG alarm is cleared via the STATUS_CLEAR register or the MAX78615+PPM is reset. If the VX_SAG bit is cleared in the STICKY register, then the alarm bit will be automatically cleared and any unmasked AL pin set high as soon as the indicator VSAGX is greater than the programmable threshold.

The sag detection can be used to monitor or record the quality of the power line or utilize the sag alarm pin to notify external devices (for example a host microprocessor) of a pending power-down. The external device can then enter a power-down mode (for example saving data or recording the event) before a power outage. Figure 14 shows a sag event and how the alarm bit is set by the firmware (in the case of the STICKY register bit cleared).

Example: Set the detection interval to one-half of a line cycle (60Hz line frequency) with a MAX78700.

$$VSAG_INT = \frac{\frac{T_{line}}{2}}{\frac{1}{f_{sample}}} = \frac{f_{sample}}{2f_{line}} = \frac{3174.6}{2 \times 60} = 26.455$$

Voltage Sign Outputs

The device can optionally output the sign of the phase or line voltages VA, VB, VC on dedicated pins. This functionality is enabled individually for each phase by setting the VSGNA, VSGNB and VSGNC bits in the CONFIG register. If a VSGNx bit is set, the sign of the voltage Vx drives the state of the corresponding pin if enabled as an output. The time delay of the sign output versus the sign of the actual voltage is approximately 2 sample times. Resetting a VSGNx bit disables this functionality and makes the corresponding pin available as a general-purpose input/output. See [Table 23](#).

Alarm Monitoring

Low-rate alarm conditions are determined every accumulation interval. If results for Die Temperature, AC Frequency, or RMS Voltage exceeds or drops below user-configurable thresholds, then a respective alarm bit in the STATUS register is set. For RMS Current results, a maximum threshold is provided for detecting over current conditions with the load. For Power Factor results, a minimum threshold is provided. See [Table 24](#).

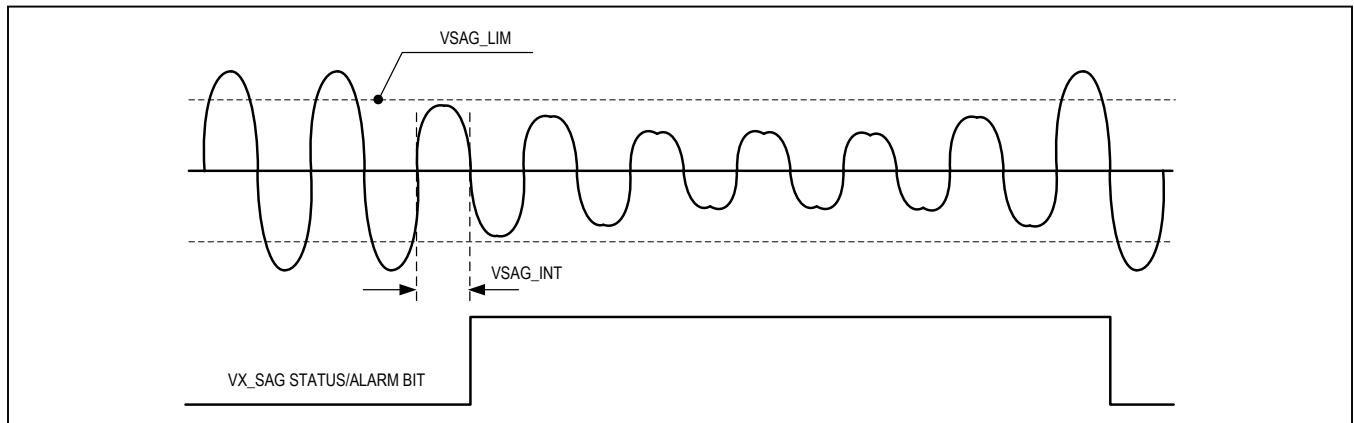

Figure 14. Voltage Sag Event

Table 23. Line Voltage Sign Output Enable

DIO_STATE DIO_DIR DIO_POL	24-PIN TQFN	VSGNx
Bit 6	4	VSGNA
Bit 7	3	VSGNB
Bit 8	2	VSGNC

Table 24. Alarms Thresholds Registers

REGISTER	LSB	DESCRIPTION
T_MAX	$^{\circ}\text{C}/2^{10}$	Threshold value which Temperature must exceed to trigger alarm.
T_MIN	$^{\circ}\text{C}/2^{10}$	Threshold value which Temperature must drop below to trigger alarm.
F_MAX	$\text{Hz}/2^{16}$	Threshold value which Frequency must exceed to trigger alarm.
F_MIN	$\text{Hz}/2^{16}$	Threshold value which Frequency must drop below to trigger alarm.
VRMS_MAX	$\text{FSV}/2^{23}$	Threshold value which RMS Voltage must exceed to trigger alarm.
VRMS_MIN	$\text{FSV}/2^{23}$	Threshold value which RMS Voltage must drop below to trigger alarm.
IRMS_MAX	$\text{FSI}/2^{23}$	Threshold value which RMS current must exceed to trigger alarm.
PF_MIN	$1/2^{22}$	Threshold value which power factor must drop below to trigger alarm.

Imbalance of the three voltages and three currents is monitored and reported via dedicated alarm bits if they exceed respective maximum threshold `V_IMB_MAX` and `I_IMB_MAX`. See the [Current and Voltage Imbalance](#) section for details. See [Table 25](#).

The STATUS register also provides Sag voltage alarms. A configurable RMS voltage threshold and selectable Interval is provided as described below and in the [Voltage Sag Detection](#) section. See [Table 26](#).

Status Registers

The STATUS register is used to monitor the status of the device and user-configurable alarms. All other registers mentioned in this section share the same bit descriptions.

The STICKY register determines which alarm/status bits are sticky and which track the current status of the condition. Each alarm bit defined as sticky (once triggered) holds its alarm status until the user clears it using the STATUS_RESET register. Any sticky bit not set allows the respective status bit to clear when the condition clears.

The STATUS_SET and the STATUS_RESET registers allow the user to force status bits on or off, respectively, without fear of affecting unintended bits. A bit set in the STATUS_SET register sets the respective bit in the STATUS register, and a bit set in the STATUS_RESET register clears it. STATUS_SET and STATUS_RESET are both cleared after the status bit is set or reset. [Table 27](#) lists the bit mapping for the all status-related registers.

Reset State

During and immediately after reset, all DIOs are configured as inputs until configured. Interface configuration

pins (IFC0/MP8, IFC1/MP0) and address pins (AD1/MP6, SCK/AD0/MP1) are input pins sampled during reset/initialization to select the serial host interface and set device addresses (for I²C and UART modes). If the IFC0 pin is low, the device operates in the SPI mode. Otherwise, the state of IFC1 and the AD[1:0] pins determine the operating mode and device address.

DIO_STATE

The DIO_STATE register contains the current status of the DIOs. The user can acquire the state of a DIO, if configured as input (1 = high, 0 = low), or control its state, if configured as output.

DIO_DIR

The DIO_DIR register sets the direction of the pins, where 1 is input and 0 is output. For pins used as part of the selected serial interface, the DIO_DIR register has no effect. If a DIO is defined as an input, a weak internal pullup is active. DIO pins must remain configured as an input if directly connecting to GND/VDD. Otherwise, it is recommended to use external pullup or pulldown resistors accordingly.

DIO_POL

DIOs configured as outputs are by default active low. The logic 0 state is on. This can be modified using the DIO_POL register using the same bit definition as the DIO_STATE register. Any corresponding bit set in the DIO_POL register inverts the same DIO output so that it becomes active high.

Table 25. Imbalance Thresholds Registers

REGISTER	DESCRIPTION
V_IMB_MAX	Percentage Threshold value which Voltage Imbalance must exceed to trigger alarm.
I_IMB_MAX	Percentage Threshold value which Current Imbalance must exceed to trigger alarm.

Table 26. Voltage Sag Thresholds Registers

REGISTER	DESCRIPTION
VSAG_LIM	Threshold value (in RMS) which voltage must go below to trigger a sag alarm.
VSAG_INT	Interval (in samples) over which the voltage must be below the threshold. Should be set in increments of half cycles (i.e., 22 samples per half cycle at 60Hz).

Table 27. Status-Related Registers Bitmap

BIT	NAME	STICKABLE?	DESCRIPTION
23	DRDY	Yes	New low rate results (data) ready
22	OV_FREQ	Yes	Frequency over High Limit
21	UN_FREQ	Yes	Under Low Frequency Limit
20	OV_TEMP	Yes	Temperature over High Limit
19	UN_TEMP	Yes	Under Low Temperature Limit
18	OV_VRMSC	Yes	RMS Voltage C Over Limit
17	UN_VRMSC	Yes	RMS Voltage C Under Limit
16	OV_VRMSB	Yes	RMS Voltage B Over Limit
15	UN_VRMSB	Yes	RMS Voltage B Under Limit
14	OV_VRMSA	Yes	RMS Voltage A Over Limit
13	UN_VRMSA	Yes	RMS Voltage A Under Limit
12	UN_PFC	Yes	Power Factor C Under Limit
11	UN_PFB	Yes	Power Factor B Under Limit
10	UN_PFA	Yes	Power Factor A Under Limit
9	OV_IRMSC	Yes	RMS Current C Over Limit
8	OV_IRMSB	Yes	RMS Current B Over Limit
7	OV_IRMSA	Yes	RMS Current A Over Limit
6	VC_SAG	Yes	Voltage C Sag Condition Detected
5	VB_SAG	Yes	Voltage B Sag Condition Detected
4	VA_SAG	Yes	Voltage A Sag Condition Detected
3	V_IMBAL	Yes	Voltage Imbalance Detected
2	I_IMBAL	Yes	Current Imbalance Detected
1	XSTATE	No	External Oscillator is clocking source
0	RESET	Always	Set by device after any type of reset

Table 28. Digital I/O Functionality

DIO_STATE DIO_DIR DIO_POL	24-PIN TQFN	FUNCTION AT POWER- ON/RESET	SPI	UART	I ² C	MASK
Bit 0	16	IFC1	MP0			—
Bit 1	15	AD0	SCK	MP1		—
Bit 2	14	—	SDI	RX	SDAI	—
Bit 3	13	—	SDO	TX	SDAO	—
Bit 4	4	—	MP4			MASK4
Bit 5	5	—	SSB	MP5	SCL	—
Bit 6	4	AD1	MP6			—
Bit 7	3	—	MP7			MASK7
Bit 8	2	IFC0	MP8			—
Bit 9:23	—	—	—			—

Alarm Masks

The device provides MASK registers for signaling the status of any STATUS bits to one of the MP pins. These MASK registers have the same bit mapping as the STATUS register. The user must first enable the respective pin as an output before the MP can be driven to its active state. See [Table 29](#).

Command Register

The Command Register is located at address 0x00. Use this register to perform specific tasks such as saving coefficients and nonvolatile register defaults into flash memory. It also allows initiation of integrated calibration routines. See [Table 30](#).

Normal Operation

The Normal Operations Command bits are applied in all normal operating cases. See [Table 31](#).

Calibration Command

The Calibration Command starts the calibration process for the selected inputs. It is assumed that appropriate input signals and target values are applied. When a gain calibration process completes, bits 23:17 are cleared along with bits associated with channels that calibrated successfully. When an offset calibration completes, 23:17 are cleared but the corresponding offset bits will remain set. See [Table 32](#).

Table 29. Mask Registers

PIN NAME	REGISTER	DESCRIPTION
MP4	MASK4	A combination of a bit set in both the STATUS register and a MASK register causes the assigned DIO_STATE/pin to be activated (default active-low).
MP7	MASK7	

Table 30. Command Register Commands

VALUE (HEX)	DESCRIPTION
0x00xxxx	Normal Operations Command
0xCA/CBxxxx	Calibration Command
0xACCxxx	Flash Access Command
0xBDxxxx	Soft Reset Command
0xECxxxx	Reset Energy Command

Table 31. Normal Operation Command Details

BIT(S)	VALUE	DESCRIPTION
6	RTRK	1= reset the minima and maxima registers for all monitored variables. This bit automatically clears to zero when the reset completes.

Table 32. Calibration Command Details

BIT(S)	VALUE	DESCRIPTION
23:17	0x65	“Calibrate” Command
16		1 = Calibrate Voltage for Phase C, 0 = no action
15		1 = Calibrate Voltage for Phase B, 0 = no action
14		1 = Calibrate Voltage for Phase A, 0 = no action
13		1 = Calibrate Current for Phase C, 0 = no action
12		1 = Calibrate Current for Phase B, 0 = no action
11		1 = Calibrate Current for Phase A, 0 = no action
10		1 = Calibrate Temperature, 0 = no action
9		Calibrate Offset vs. Gain (0 = calibrate Gain; 1 = calibrate Offset)
8:0		Reserved, set to 0

Note: During calibration, the “line-lock” bit should be set for best results.

Examples:

Calibrate gains of voltage and current of Phase A
 Start Command: COMMAND = 0xCA4830
 Successful Calibration: COMMAND is reset to 0x000030
 Calibration of current failed: COMMAND is reset to 0x000830
 Calibrate gains of all three voltages.
 Start Command: COMMAND = 0xCBC030
 Successful Calibration: COMMAND is reset to 0x000030
 Calibration of voltages B and C failed: COMMAND is reset to 0x018030

Save to Flash Command

Use the 0xACC command to save to flash the calibration coefficients and defaults for nonvolatile registers. Upon reset or power-on, the values stored in flash will become new system defaults. [Table 33](#) describes the ACC command bits. After execution of this command, the device resets the COMMAND register bits [23:8] to zero.

Example:

Save all current settings to flash memory, to make them permanent.
 Write COMMAND = 0xACC230. After execution of this command, the MAX78615+PPM resets the COMMAND register to 0x000030.

Soft Reset Command

Use the 0xBD command to soft reset the device firmware. [Table 34](#) describes the command bits. After execution of this command, the device resets the firmware and restarts.

Energy Clear Command

Use this command to clear all energy counters. [Table 35](#) describes the command bits.

Configuration Register

A CONFIG register is provided for system settings, such as sensor configuration, current sensor type, power computations and hardware gains. See [Table 36](#) for register bit descriptions.

Table 33. Save to Flash Command Bits

BIT(S)	VALUE	DESCRIPTION
23:0	0xACC200	Save defaults to flash memory for NV registers.

Table 34. Soft Reset Command Bits

BIT(S)	VALUE	DESCRIPTION
23:0	0xBDxxxx	Soft reset the device.

Table 35. Energy Clear Command Bits

BIT(S)	VALUE	DESCRIPTION
23:0	0xEC0000	Clear All Energy Counters

Table 36. CONFIG Register Bit Descriptions

BIT(S)	NAME	DESCRIPTION
23	—	Reserved for future use, write as zeroes
22	INV_AV3	Invert voltage samples AV3
21	INV_AV2	Invert voltage samples AV2
20	INV_AV1	Invert voltage samples AV1
19	VSGNC	Drive MP8 with sign of voltage C
18	VSGNB	Drive MP7 with sign of voltage B
17	VSGNA	Drive MP6 with sign of voltage A
16	—	Reserved for future use, write as zeroes
15	—	Reserved for future use, write as zeroes
14	—	Reserved for future use, write as zeroes
13	—	Reserved for future use, write as zeroes
12	—	Reserved for future use, write as zeroes
11	—	Reserved for future use, write as zeroes
10	—	Reserved for future use, write as zeroes
9	—	Reserved for future use, write as zeroes
8	—	Reserved for future use, write as zeroes
7:6	PPHASE	Ignore phase for total power computations 00: none 01: phase A 10: phase B 11: phase C
5	VDELTA	Compute delta voltage between phases
4:3	VPHASE	Missing sensor on voltage input 00: none missing 01: AV1 10: AV2 11: AV3
2	INEUTRAL	Current sensor in neutral leg.
1:0	IPHASE	Missing sensor on current input 00: none missing 01: AI1 10: AI2 11: AI3

Control Register

This register is used to control the basic operating modes of the MAX78615+PPM. See [Table 37](#) for register bit descriptions.

User Nonvolatile Storage

The firmware provides eight scratch registers that are stored in flash on a flash save command(0xACC2xx). These registers have no direct function in the firmware functionality and can be used without effect by the user. See [Table 38](#).

Register Access

All user registers are contained in a 256-word (24-bits each) area of the on-chip RAM and can be accessed through the UART, SPI, or I²C interfaces. These registers are byte-addressable via the UART interface and word-addressable via the SPI and I²C interfaces. These registers consist of read (output), write (input), and read/write in the case of the Command Register. **Writing to reserved registers or to unspecified memory locations could result in device malfunction or unexpected results.**

Data Types

The input and output registers have different data types, depending on their assignment and functions. The notation used indicates whether the number is signed, unsigned, or bit-mapped and the location of the binary point. All registers, by default, are stored as 24-bit two's complement values. This gives the registers' raw value (Rr) a theoretical range of 2²³ - 1 (0x7FFFFFF) to -2²³ (0x800000). These registers are expressed, by convention, with the notation of S.N, which implies the interpreted value of the register (Ri) is the raw value (Rr) divided by 2^N.

S	Indicates a signed fixed point two's compliment value.
U	Indicates an unsigned fixed point value.
N	Indicates the number of bits to the right of the binary point. The numbers value can be expressed by dividing the binary or two's compliment value by 2 ⁿ .

Example 1:

S.0 (INT) is a 24-bit signed fixed-point number with 0 fraction bits to the right of the binary point and a range of -2²³ to +2²³ - 1. 0x200000 = 2²¹ = 2097152.

Table 37. Control Register Bit Descriptions

BIT(S)	NAME	DESCRIPTION
23:6	NA	Reserved/0
6	DIR	1: DIO_STATE[5]/MP5 pin is used in UART mode to indicate the device is selected and may transmit or deselected and will not transmit. 0: DIO_STATE[5] is unaffected.
5	lock	Line Lock 1 = lock to line cycle; 0 = independent of line voltage
4	tc	Enable Gain/Temperature compensation 1 = enable; 0 = disable. This bit allows the firmware to modify the system gain based on measured chip temperature.
3	NA	Reserved/0
2	strg	Single-Target SSI Mode: SSI ignores the devaddr and AD# pins. Will respond to all SSI commands. Only checked during initialization.
1:0	NA	Reserved/0

Table 38. User Nonvolatile Storage Registers

REGISTER	DEFAULT	DESCRIPTION
UNV0	62	User Nonvolatile Storage
UNV1	667	User Nonvolatile Storage
UNV2	0	User Nonvolatile Storage
UNV3	0	User Nonvolatile Storage

REGISTER	DEFAULT	DESCRIPTION
UNV4	0	User Nonvolatile Storage
UNV5	0	User Nonvolatile Storage
UNV6	0	User Nonvolatile Storage
UNV7	0	User Nonvolatile Storage

Example 2:

S.21 is a 24-bit signed fixed-point number with 21 fraction bits to the right of the binary point and a range of -4.0 to 4-2-21. The value can be expressed by dividing the two's compliment value by 2²¹. 0x200000 = 1. 0x800000 = -4.0.

Example 3:

U.24 is a 24-bit unsigned fixed-point number with 24 fraction bits to the right of the binary point and a range of 1.0-2^X to 0. The value can be expressed by dividing the binary value by 2^X = 2^X = 0.125. 0x800000 = 2^X = 0.5.

Indirect Read Access

The device firmware supplies a method for indirect read access to the device RAM memory. The firmware writes the contents of IND_RD_DATA with the content of RAM at the word address indicated by (IND_RD_ADDR and 0x0000FF). That value (IND_RD_ADDR and 0x0000FF) is then written back into IND_RD_ADDR to indicate the read has completed. The check/action for the contents of

IND_RD_ADDR is performed at every high rate sample. See [Table 39](#).

Indirect Write Access

The device firmware supplies a method for indirect write access to the device RAM memory. If any of the upper 12 bits of IND_WR_ADDR are nonzero, the firmware writes the contents of IND_WR_DATA into the word address indicated by (IND_WR_ADDR and 0x0000FF). That value (IND_WR_ADDR and 0x0000FF) is then written back into IND_WR_ADDR to indicate the write has completed. The check/action for the contents of IND_WR_ADDR is performed at every high rate sample. See [Table 40](#).

Register Locations

Use word addresses for I²C and SPI interfaces and byte addresses for the SSI (UART) protocol. Nonvolatile (NV) register defaults are indicated with a "Y." All other registers are initialized as described in the [Functional Description](#). See [Table 41](#).

Table 39. Indirect Read Access Registers

REGISTER	DESCRIPTION
IND_RD_ADDR	Indirect Read Address
IND_RD_DATA	Indirect Read Data

Table 40. Direct Read Access Registers

REGISTER	DESCRIPTION
IND_WR_DATA	Indirect Write Data
IND_WR_ADDR	Indirect Write Address

Table 41. Register Map

WORD ADDR (HEX)	BYTE ADDR (HEX)	REGISTER NAME	TYPE	NV	DESCRIPTION
0	0	COMMAND	INT	Y	Firmware action/commands
1	3	FW_VERSION	INT		Firmware version
2	6	CONFIG	INT	Y	Selects input configuration
3	9	CONTROL	INT	Y	Device behavior control
4	C	CYCLE	INT		High-rate sample counter
5	F	DIVISOR	INT		Actual samples in previous accumulation interval
6	12	FRAME	INT		Low-rate sample counter
7	15	STATUS	INT		Alarm and device status bits
8	18	DIO_STATE	INT		State of DIO pins
9	1B	IND_WR_DATA	INT		Indirect Write Data
A	1E	IND_WR_ADDR	INT		Indirect Write Address
B	21	IND_RD_ADDR	INT		Indirect Read Address

Table 41. Register Map (continued)

WORD ADDR (HEX)	BYTE ADDR (HEX)	REGISTER NAME	TYPE	NV	DESCRIPTION
C	24	IND_RD_DATA	INT		Indirect Read Data
D	27	VA	S.23		Instantaneous Voltage
E	2A	VB	S.23		Instantaneous Voltage
F	2D	VC	S.23		Instantaneous Voltage
10	30	IA	S.23		Instantaneous Current
11	33	IB	S.23		Instantaneous Current
12	36	IC	S.23		Instantaneous Current
13	39	VA_RMS	S.23		RMS Voltage
14	3C	VB_RMS	S.23		RMS Voltage
15	3F	VC_RMS	S.23		RMS Voltage
16	42	VT_RMS	S.23		RMS Voltage average (Total/3)
17	45	VFUND_A	S.23		Fundamental Voltage
18	48	VFUND_B	S.23		Fundamental Voltage
19	4B	VFUND_C	S.23		Fundamental Voltage
1A	4E	IA_PEAK	S.23		Peak Current
1B	51	IB_PEAK	S.23		Peak Current
1C	54	IC_PEAK	S.23		Peak Current
1D	57	IA_RMS	S.23		RMS Current
1E	5A	IB_RMS	S.23		RMS Current
1F	5D	IC_RMS	S.23		RMS Current
20	60	IT_RMS	S.23		RMS Current average (Total/3)
21	63	IFUND_A	S.23		Fundamental Current
22	66	IFUND_B	S.23		Fundamental Current
23	69	IFUND_C	S.23		Fundamental Current
24	6C	WATT_A	S.23		Active Power
25	6F	WATT_B	S.23		Active Power
26	72	WATT_C	S.23		Active Power
27	75	VAR_A	S.23		Reactive Power
28	78	VAR_B	S.23		Reactive Power
29	7B	VAR_C	S.23		Reactive Power
2A	7E	VA_A	S.23		Apparent Power
2B	81	VA_B	S.23		Apparent Power
2C	84	VA_C	S.23		Apparent Power

Table 41. Register Map (continued)

WORD ADDR (HEX)	BYTE ADDR (HEX)	REGISTER NAME	TYPE	NV	DESCRIPTION
2D	87	WATT_T	S.23		Active Power Total
2E	8A	VAR_T	S.23		Reactive Power Total
2F	8D	VA_T	S.23		Apparent Power Total
30	90	PFUND_A	S.23		Fundamental Power
31	93	PFUND_B	S.23		Fundamental Power
32	96	PFUND_C	S.23		Fundamental Power
33	99	QFUND_A	S.23		Fundamental Reactive Power
34	9C	QFUND_B	S.23		Fundamental Reactive Power
35	9F	QFUND_C	S.23		Fundamental Reactive Power
36	A2	VAFUNDA	S.23		Fundamental Volt Amperes
37	A5	VAFUNDB	S.23		Fundamental Volt Amperes
38	A8	VAFUNDC	S.23		Fundamental Volt Amperes
39	AB	PFA	S.22		Power Factor
3A	AE	PFB	S.22		Power Factor
3B	B1	PFC	S.22		Power Factor
3C	B4	PF_T	S.22		Total Power Factor
3D	B7	FREQ	S.16		Line Frequency
3E	BA	TEMPC_A	S.10		Chip Temperature (Celsius°) Channel A
3F	BD	TEMPC_B	S.10		Chip Temperature (Celsius°) Channel B
40	C0	TEMPC_C	S.10		Chip Temperature (Celsius°) Channel C
41	C3	WHA_POS	INT		Received Active Energy Counter
42	C6	WHB_POS	INT		Received Active Energy Counter
43	C9	WHC_POS	INT		Received Active Energy Counter
44	CC	WHA_NEG	INT		Delivered Active Energy Counter
45	CF	WHB_NEG	INT		Delivered Active Energy Counter
46	D2	WHC_NEG	INT		Delivered Active Energy Counter
47	D5	VARHA_POS	INT		Reactive Energy Leading Counter
48	D8	VARHB_POS	INT		Reactive Energy Leading Counter
49	DB	VARHC_POS	INT		Reactive Energy Leading Counter
4A	DE	VARHA_NEG	INT		Reactive Energy Lagging Counter
4B	E1	VARHB_NEG	INT		Reactive Energy Lagging Counter
4C	E4	VARHC_NEG	INT		Reactive Energy Lagging Counter
4D	E7	MIN0	NA		Minimum Recorded Value 1

Table 41. Register Map (continued)

WORD ADDR (HEX)	BYTE ADDR (HEX)	REGISTER NAME	TYPE	NV	DESCRIPTION
4E	EA	MIN1	NA		Minimum Recorded Value 2
4F	ED	MIN2	NA		Minimum Recorded Value 3
50	F0	MIN3	NA		Minimum Recorded Value 4
51	F3	MIN4	NA		Minimum Recorded Value 5
52	F6	MIN5	NA		Minimum Recorded Value 6
53	F9	MIN6	NA		Minimum Recorded Value 7
54	FC	MIN7	NA		Minimum Recorded Value 8
55	FF	MAX0	NA		Maximum Recorded Value 1
56	102	MAX1	NA		Maximum Recorded Value 2
57	105	MAX2	NA		Maximum Recorded Value 3
58	108	MAX3	NA		Maximum Recorded Value 4
59	10B	MAX4	NA		Maximum Recorded Value 5
5A	10E	MAX5	NA		Maximum Recorded Value 6
5B	111	MAX6	NA		Maximum Recorded Value 7
5C	114	MAX7	NA		Maximum Recorded Value 8
5D	117	MMADDR0	INT	Y	Min/Max Monitor address 1
5E	11A	MMADDR1	INT	Y	Min/Max Monitor address 2
5F	11D	MMADDR2	INT	Y	Min/Max Monitor address 3
60	120	MMADDR3	INT	Y	Min/Max Monitor address 4
61	123	MMADDR4	INT	Y	Min/Max Monitor address 5
62	126	MMADDR5	INT	Y	Min/Max Monitor address 6
63	129	MMADDR6	INT	Y	Min/Max Monitor address 7
64	12C	MMADDR7	INT	Y	Min/Max Monitor address 8
65	12F	BUCKETL	INT	Y	Energy Bucket Size – Low word
66	132	BUCKETH	INT	Y	Energy Bucket Size – High word
67	135	SAMPLES	INT	Y	Minimum high-rate samples per accumulation interval
68	138	STATUS_CLEAR	INT		Used to reset alarm/status bits
69	13B	STATUS_SET	INT		Used to set/force alarm/status bits
6A	13E	DEVADDR	INT	Y	High order address bits for I2C and UART interfaces
6B	141	BAUD	INT	Y	Baud rate for UART interface
6C	144	DIO_DIR	INT	Y	Direction of DIO pins. 1 = Input ; 0 = Output
6D	147	DIO_POL	INT	Y	Polarity of DIO pins. 1 = Active High ; 0 = Active Low
6E	14A	CALCYCS	INT	Y	Number of calibration cycles to average

Table 41. Register Map (continued)

WORD ADDR (HEX)	BYTE ADDR (HEX)	REGISTER NAME	TYPE	NV	DESCRIPTION
6F	14D	HPF_COEF_I	S.23	Y	Current input HPF coefficient. Positive values only
70	150	HPF_COEF_V	S.23	Y	Voltage input HPF coefficient. Positive values only
71	153	PHASECOMP1	S.21	Y	Phase compensation (± 4 samples) for AV1 input
72	156	PHASECOMP2	S.21	Y	Phase compensation (± 4 samples) for AV2 input
73	159	PHASECOMP3	S.22	Y	Phase compensation (± 4 samples) for AV3 input
74	15C	HARM	INT	Y	Harmonic Selector, default: 1 (fundamental)
75	15E	V1_OFFS	S.23	Y	Voltage Offset Calibration
76	162	V2_OFFS	S.23	Y	Voltage Offset Calibration
77	165	V3_OFFS	S.23	Y	Voltage Offset Calibration
78	168	V1_GAIN	S.21	Y	Voltage Gain Calibration. Positive values only
79	16B	V2_GAIN	S.21	Y	Voltage Gain Calibration. Positive values only
7A	16E	V3_GAIN	S.21	Y	Voltage Gain Calibration. Positive values only
7B	171	I1_OFFS	S.23	Y	Current Offset Calibration
7C	174	I2_OFFS	S.23	Y	Current Offset Calibration
7D	177	I3_OFFS	S.23	Y	Current Offset Calibration
7E	17A	I1_GAIN	S.21	Y	Current Gain Calibration. Positive values only.
7F	17D	I2_GAIN	S.21	Y	Current Gain Calibration. Positive values only.
80	180	I3_GAIN	S.21	Y	Current Gain Calibration. Positive values only.
81	183	IARMS_OFF	S.23	Y	RMS Current dynamic offset adjust. Positive values only.
82	186	IBRMS_OFF	S.23	Y	RMS Current dynamic offset adjust. Positive values only.
83	189	ICRMS_OFF	S.23	Y	RMS Current dynamic offset adjust. Positive values only.
84	18C	QA_OFFS	S.23	Y	Reactive Power dynamic offset adjust. Positive values only.
85	18F	QB_OFFS	S.23	Y	Reactive Power dynamic offset adjust. Positive values only.
86	192	QC_OFFS	S.23	Y	Reactive Power dynamic offset adjust. Positive values only.
87	195	PA_OFFS	S.23	Y	Active Power dynamic offset adjust. Positive values only.
88	198	PB_OFFS	S.23	Y	Active Power dynamic offset adjust. Positive values only.
89	19B	PC_OFFS	S.23	Y	Active Power dynamic offset adjust. Positive values only.
8A	19E	T_GAIN	S.21	Y	Temperature Slope Calibration (Factory Set)
8B	1A1	T_OFFS1	INT	Y	Temperature Offset Calibration Remote Channel 1
8C	1A4	T_OFFS2	INT	Y	Temperature Offset Calibration Remote Ch. B
8D	1A7	T_OFFS3	INT	Y	Temperature Offset Calibration Remote Ch. C
8E	1AA	VSAG_INT	INT	Y	Voltage sag detect interval (high-rate samples)
8F	1AD	V_IMB_MAX	S.23	Y	Voltage imbalance alarm limit. Positive values only

Table 41. Register Map (continued)

WORD ADDR (HEX)	BYTE ADDR (HEX)	REGISTER NAME	TYPE	NV	DESCRIPTION
90	1B0	I_IMB_MAX	S.23	Y	Current imbalance alarm limit. Positive values only.
91	1B3	V_TARGET	S.23	Y	Calibration Target for Voltages. Positive values only.
92	1B6	VRMS_MIN	S.23	Y	Voltage lower alarm limit. Positive values only.
93	1B9	VRMS_MAX	S.23	Y	Voltage upper alarm limit. Positive values only.
94	1BC	VSAG_LIM	S.23	Y	RMS Voltage Sag threshold. Positive values only.
95	1BF	I_TARGET	S.23	Y	Calibration Target for Currents. Positive values only.
96	1C2	IRMS_MAX	S.23	Y	Current upper alarm limit. Positive values only.
97	1C5	T_TARGET	S.10	Y	Temperature calibration target
98	1C8	T_MIN	S.10	Y	Temperature Alarm Lower Limit
99	1CB	T_MAX	S.10	Y	Temperature Alarm Upper Limit
9A	1CE	PF_MIN	S.22	Y	Power Factor lower alarm limit
9B	1D1	F_MIN	S.16	Y	Frequency Alarm Lower Limit
9C	1D4	F_MAX	S.16	Y	Frequency Alarm Upper Limit
9D	1D7	MASK4	INT	Y	Alarm/status mask for MP4 output pin
9E	1DA	MASK7	INT	Y	Alarm/status mask for MP7 output pin
9F	1DD	STICKY	INT	Y	Alarm/status bits to hold until cleared by host
A0	1E0	RSVD	NA	Y	Reserved
A1	1E3	RSVD	NA	Y	Reserved
A2	1E6	UNV0	NA	Y	User Nonvolatile Storage
A3	1E9	UNV1	NA	Y	User Nonvolatile Storage
A4	1FC	UNV2	NA	Y	User Nonvolatile Storage
A5	1EF	UNV3	NA	Y	User Nonvolatile Storage
A6	1F2	UNV4	NA	Y	User Nonvolatile Storage
A7	1F5	UNV5	NA	Y	User Nonvolatile Storage
A8	1F8	UNV6	NA	Y	User Nonvolatile Storage
A9	1FB	UNV7	NA	Y	User Nonvolatile Storage

Serial Interfaces

All user registers are contained in a 256-word (24-bits each) area of the on-chip RAM and can be accessed through the UART, SPI, or I²C interfaces. While access to a single byte is possible with some interfaces, it is highly recommended that the user access words (or multiple words) of data with each transaction.

Only one interface can be active at a time. The interface selection pins are sampled at the end of a reset or power-on sequence to determine the operating mode. See [Table 42](#).

UART Interface

The device implements a “simple serial interface” (SSI) protocol on the UART interface that features:

- Support for single and multipoint communications
- Transmit (direction) control for an RS-485 transceiver
- Efficient use of a low bandwidth serial interface
- Data integrity checking

The default configuration is 38400 baud, 8-bit, no-parity, 1 stop-bit, no flow control. The value in the BAUD register

determines the baud rate to be used. Example: To select a 9600 baud rate, the user writes a decimal 9600 to the BAUD register. The new rate will not take effect immediately. It must be saved to flash and takes effect at the next reset. The maximum BAUD value is limited to 115200.

RS-485 Support

The SSB/MP5/SCL pin can be used to drive an RS-485 transceiver output enable or direction pin. The implemented protocol supports a full-duplex 4-wire RS-485 bus. When the DIR bit is set in the Control Register, then the DIO_STATE[5] pin reflects if the device has been selected or deselected by an SSI target command. If DIO_DIR[5] is also set to an output, then the MP5 pin reflects this state. See [Figure 15](#).

Table 42. Serial Interface Selection

INTERFACE MODE	IFC0	IFC1
SPI	0	X (don't care)
UART	1	0
I ² C	1	1

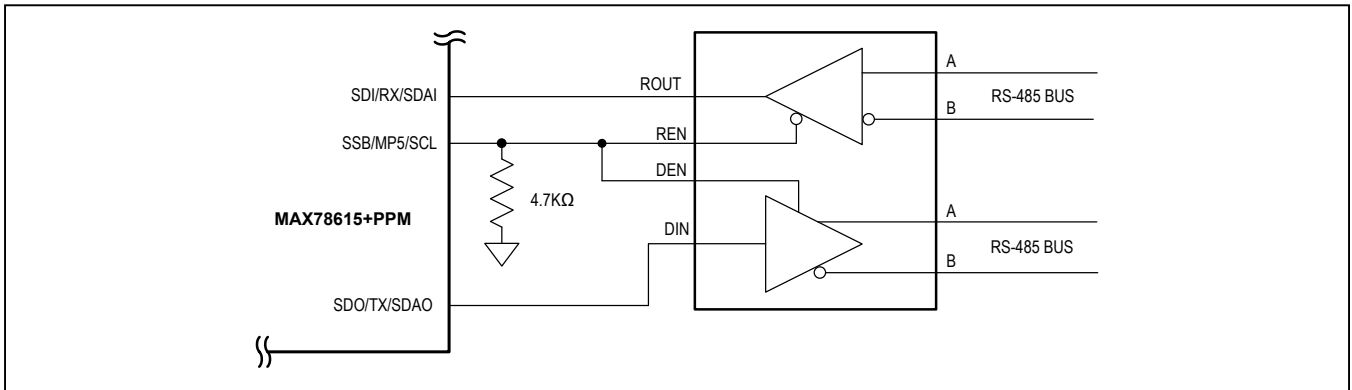

Figure 15. RS-485 Bus Protocol

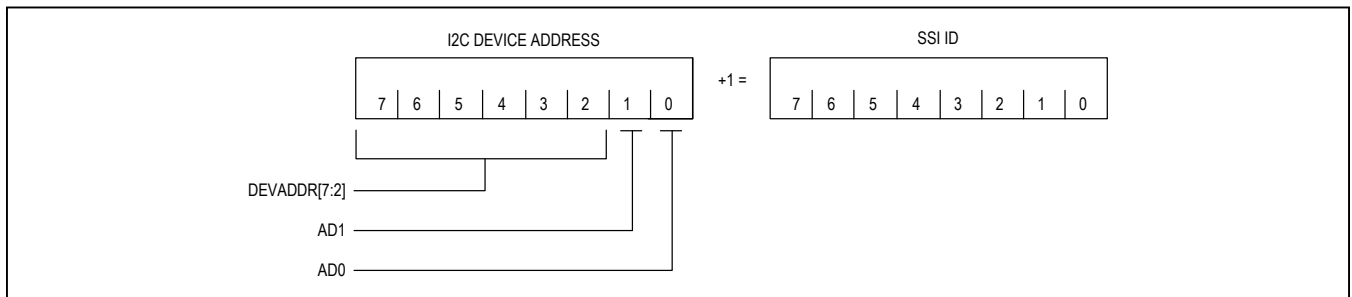

Figure 16. Multipoint Device Address Communication System

Device Address Configuration

The SSI protocol utilizes 8-bit addressing for multipoint communications. The usable SSI ID range is 1 to 254. In multipoint systems with more than four targets, the user must configure device address bits in the DEVADDR according to the formula SSI ID = Device Address +1 (Figure 16).

If the CONTROL[2]/strg bit is set on startup, then the SSI protocol assumes it is the only device in the system and ignore the SSI ID and responds to all commands. See Table 43.

SSI Protocol Description

The SSI protocol is command response system supporting a single master and one or more targets. The host (master) sends commands to a selected target that first verifies the integrity of the packet before sending a reply or executing a command. Failure to decode a host packet will cause the selected target to send a fail code. If the condition of a received packet is uncertain, no reply is sent.

Each target must have a unique SSI ID. Zero is not a valid SSI ID for a target device as it is used by the host to de-select all target devices.

With both address pins low on the MAX78615+PPM, the SSI ID defaults to 1 and is the “Selected” device following a reset. This configuration is intended for single target (point-to-point) systems that do not require the use of device addressing or selecting targets.

In multipoint systems, the master typically de-selects all target devices by selecting SSI ID #0. The master must then select the target with a valid SSI ID and get an acknowledgement from the slave before setting the target’s register address pointer and performing read or write operations. If no target is selected, no reply is sent. The SSB/MP5/SCL pin is asserted while the device is selected. Figure 17 shows the sequence of operation.

Master Packets

Master packets always start with the 1-byte header (0xAA) for synchronization purposes. The master then sends the byte count of the entire packet (up to 255 byte packets) followed by the payload (up to 253 bytes) and a 1-byte modulo-256 checksum of all packet bytes for data integrity checking. See Figure 18.

The payload can contain either a single command or multiple commands if the target is already selected. It can also include device addresses, register addresses, and data. All multibyte payloads are sent and received least-significant-byte first. See Table 44 for the master packet command summary.

Users only need to implement commands they actually need or intend to use. For example, only one address command is required, either 0xA1 for systems with 8 address bits or less or 0xA3 for systems with 9 to 16 address bits. Likewise, only one write, read, or select target command needs to be implemented. Select Target is not needed in systems with only one target.

Table 43. Single Target Mode Bit

NAME	DEFAULT	DESCRIPTION
strg	1	1: Single-Target SSI Mode: SSI ignores devaddr and will respond to all SSI commands. Only checked during initialization.

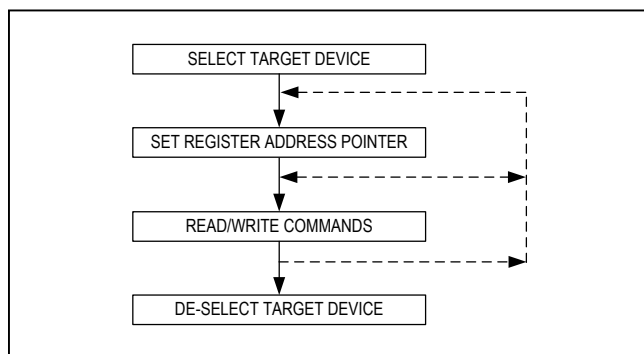

Figure 17. SSI Protocol System Sequence

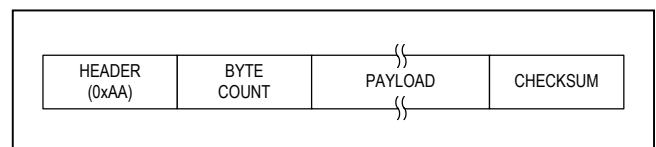

Figure 18. Master Packets

Table 44. Master Packet Command Summary

COMMAND	PARAMETERS	DESCRIPTION
0-7F		(invalid)
80-9F		(not used)
A0		Clear address
A1	[byte-L]	Set Read/Write address bits [7:0]
A2	[byte-H]	Set Read/Write address bits [15:8]
A3	[byte-L][byte-H]	Set Read/Write address bits [15:0]
A4-AF		(reserved for larger address targets)
B0-BF		(not used)
C0		De-select Target (target will Acknowledge)
C1-CE		Select target 1 to 14 (target will Acknowledge)
CF	[byte]	Select target 0 to 255 (target will Acknowledge)
D0	[data...]	Write bytes set by remainder of Byte Count
D1-DF	[data...]	Write 1 to 15 bytes
E0	[byte]	Read 0 to 255 bytes
E1-EF		Read 1 to 15 bytes
F0-FF		(not used)

Command Payload Examples

Device Selection

PAYLOAD	
0xCF Command	SSI ID

Register Address Pointer Selection

PAYLOAD	
0xA3 Command	Register Address (2 Bytes)

Small Read Command (3 bytes)

PAYLOAD	
0xE3 Command	

Large Read Command (30 bytes)

PAYLOAD	
0xE0 Command	0x1E (30 bytes)

Small Write Command (3 bytes)

PAYLOAD	
0xD3 Command	3 Bytes of Data

Large Write Command (30 bytes)

BYTE COUNT	PAYLOAD	
0x21 (34 bytes)	0xD0 Command	30 Bytes of Data

After each read or write operation, the internal address pointer is incremented to point to the address that followed the target of the previous read or write operation.

Slave Packets

The type of slave packet depends upon the type of command from the master device and the successful execution by the slave device. Standard replies include “Acknowledge” and “Acknowledge with Data.”

ACKNOWLEDGE without data

ACKNOWLEDGE with data	BYTE COUNT	READ DATA	CHECK SUM
--------------------------	---------------	--------------	--------------

If no data is expected from the slave or there is a fail code, a single byte reply is sent. If a successfully decoded command is expected to reply with data, the slave sends a packet format similar to the master packet where the header is replaced with a Reply Code and the payload contains the read data.

Failure to decode a host packet will cause the selected target to send a fail code (0xB0–0xBF) acknowledgement depending on mode of failure. Masters wishing to simplify could accept any unimplemented fail code as a Negative Acknowledge.

If no target is selected or the condition of a received packet is uncertain, no reply is sent. Timeouts can also occur when data is corrupt or no target is selected. The master should implement the appropriate timeout control logic after approximately 50 byte times at the current baud rate. When a first reply byte is received, the master should check to see if it is an SSI header or an Acknowledge. If so, the timeout timer is reset, and each subsequent receive byte will also reset the timer. If no byte is received within the timeout interval, the master can expect the slave timed out and re-send a new command.

SPI Interface

The Maxim device operates as an SPI slave. The host is expected to instigate and control all transactions. The signals used for SPI communication are defined as:

- **SSB** : (also known as **CSB**) the device SPI chip/slave select signal (active low)
- **SCK** : the clocking signal that clocks **MISO** and **MOSI** (data)
- **SDI** : (also known as **MOSI**) the data shifted into the measurement device
- **SDO** : (also known as **MISO**) the data shifted out of the measurement device

In Maxim embedded-measurement devices, these signals may have alternate functionality depending upon the device mode and/or firmware.

SPI Mode

The device operates as a slave in mode 3 (CPOL = 1, CPHA == 1) and as such the data is captured on the rising edge and propagated on the falling edge of the serial data clock (SCK). Figure 19 shows a single-byte transaction on the SPI bus. Bytes are transmitted/received MSB first.

Table 45. SSI Responses

REPLY CODE	DEFINITION
0xAA	Acknowledge with data
0xAB	Acknowledge with data (half duplex)
0xAD	Acknowledge without data.
0xB0	Negative Acknowledge (NACK).
0xBC	Command not implemented.
0xBD	Checksum failed.
0xBF	Buffer overflow (or packet too long).
- timeout -	Any condition too difficult to handle with a reply.

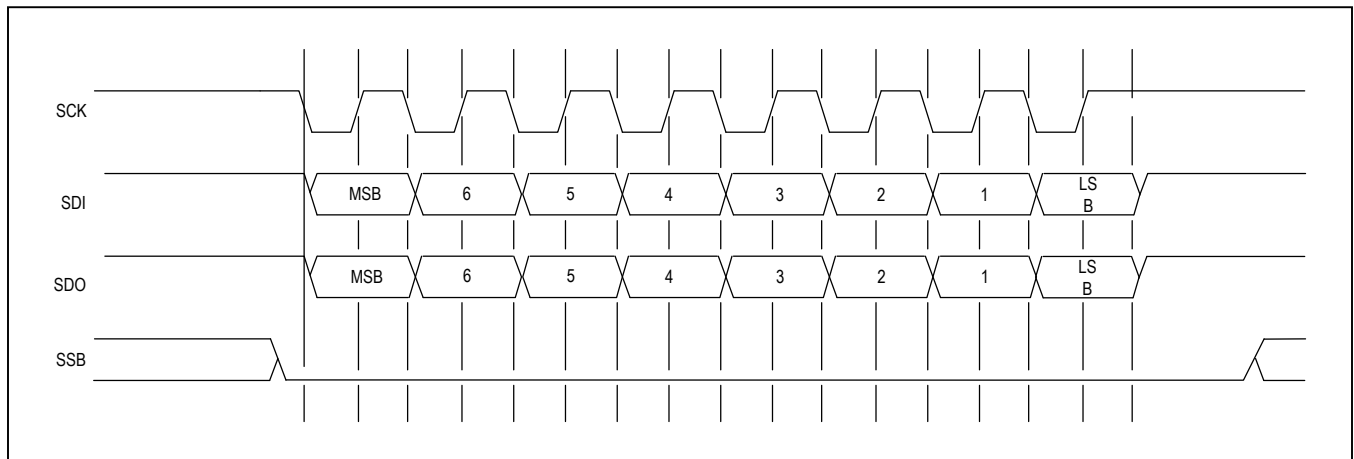

Figure 19. Signal Timing on the SPI Bus

Single Word SPI Reads

The device supplies direct read access to the device RAM memory. To read the RAM the master device must send a read command to the slave device and then clock out the resulting read data. SSB must be kept active low for the entire read transaction (command and response). SCK may be interrupted as long as SSB remains low. ADDR[5:0] is filled with the word address of the read transaction. RAM data contents are transmitted most significant byte first. ADDR[5:0] cannot exceed 0x3F. RAM words, and therefore the results, are natively 24 bits (3 bytes) long. See [Table 46](#) for the single word SPI read command (SDI). The slave responds with the data contents of the requested RAM addresses. See [Table 47](#) for the single word SPI read response (SDO).

Single Word SPI Writes

The device supplies direct write access to the device RAM memory. To write the RAM the master device must send a write command to the slave device and then clock out the

write data. SSB must be kept active low for the entire write transaction (command and data). SCK may be interrupted as long as SSB remains low. ADDR[5:0] is filled with the word address of the write transaction. RAM data contents are transmitted most significant byte first. ADDR[5:0] cannot exceed 0x3F. RAM words are natively 24 bits (3 bytes) long. See [Table 48](#) for the single word SPI write command and data (SDI). The slave SDO remains high impedance during a write access ([Figure 21](#)).

I²C Interface

The MAX78615+PPM has an I²C interface available at the SDAI, SDAO, and SCL pins. The interface supports I²C slave mode with a 7-bit address and operates at a data rate up to 400kHz. [Figure 22](#) shows two possible configurations. Configuration A is the standard configuration. The double pin for SDA also allows for isolated configuration B.

Table 46. Single Word SPI Read Command (SDI)

BYTE#	BIT 7	BIT 6	BIT 5	BIT 4	BIT 3	BIT 2	BIT 1	BIT 0
0	0x01							
1	ADDR[5:0]						0x0	
2	0							
3	0							
4	0							

Table 47. Single Word SPI Read Response (SDO)

BYTE#	BIT 7	BIT 6	BIT 5	BIT 4	BIT 3	BIT 2	BIT 1	BIT 0
0	Hi-Z (during Read Command)							
1	Hi-Z (during Read Command)							
2	DATA[23:16] at ADDR							
3	DATA[15:8] at ADDR							
4	DATA[7:0] at ADDR							

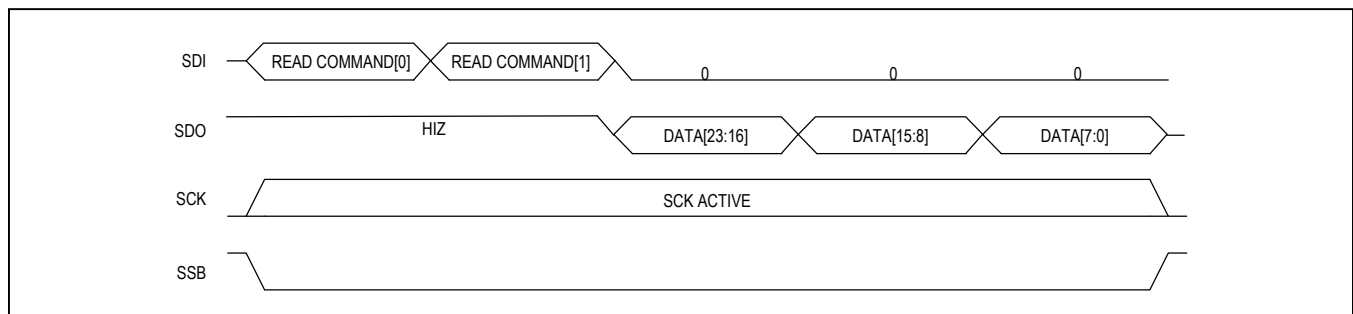

Figure 20. Single Word Read Access Timing

Table 48. Single Word SPI Write Command and Data (SDI)

BYTE#	BIT 7	BIT 6	BIT 5	BIT 4	BIT 3	BIT 2	BIT 1	BIT 0
0	0x01							
1	ADDR[5:0]						0x02	
2	DATA[23:16] @ ADDR							
3	DATA[15:8] @ ADDR							
4	DATA[7:0] @ ADDR							

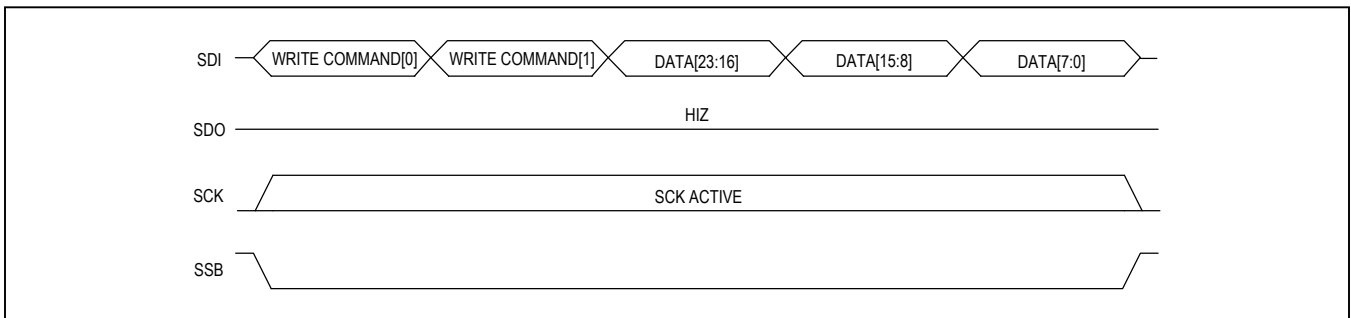

Figure 21. Single Word Write Access Timing

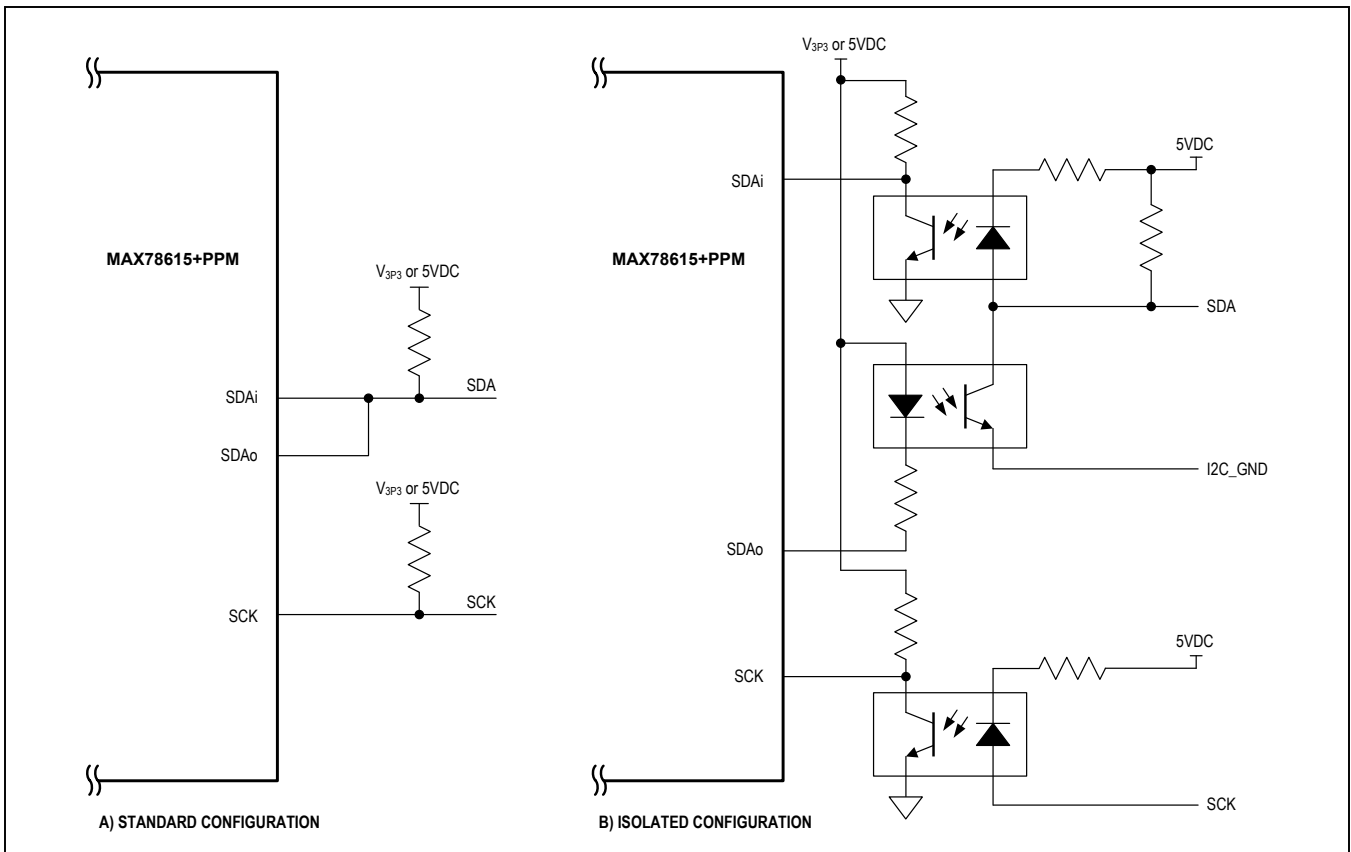

Figure 22. Configurations for I²C Interface

Device Address Configuration

By default, there are only four possible addresses for the MAX78615+PPM as defined by two external address pins. Bits 7 through 2 of the device address can then be defined by DEVADDR register (bits 7:2).

Bus Characteristics

- A data transfer may be initiated only when the bus is not busy.
- During data transfer, the data line must remain stable whenever the clock line is HIGH. Changes in the data line while the clock line is HIGH will be interpreted as a START or STOP condition.

Bus Conditions:

- **Bus not Busy (I):** Both data and clock lines are HIGH indicating an Idle Condition.
- **Start Data Transfer (S):** A HIGH to LOW transition of the SDA line while the clock (SCL) is HIGH determines a START condition. All commands must be preceded by a START condition.
- **Stop Data Transfer (P):** A LOW to HIGH transition of the SDA line while the clock (SCL) is HIGH determines a STOP condition. All operations must be ended with a STOP condition.

- **Data Valid:** The state of the data line represents valid data when, after a START condition, the data line is stable for the duration of the HIGH period of the clock signal. The data on the line must be changed during the LOW period of the clock signal. There is one clock pulse per bit of data. Each data transfer is initiated with a START condition and terminated with a STOP condition.
- **Acknowledge (A):** Each receiving device, when addressed, is obliged to generate an acknowledge after the reception of each byte. The master device must generate an extra clock pulse, which is associated with this Acknowledge bit. The device that acknowledges has to pull down the SDA line during the acknowledge clock pulse in such a way that the SDA line is stable LOW during the HIGH period of the acknowledge-related clock pulse. Of course, setup and hold times must be taken into account. During reads, a master must signal an end of data to the slave by not generating an Acknowledge bit on the last byte that has been clocked out of the slave. In this case, the slave (MAX78615+PPM) will leave the data line HIGH to enable the master to generate the STOP condition.

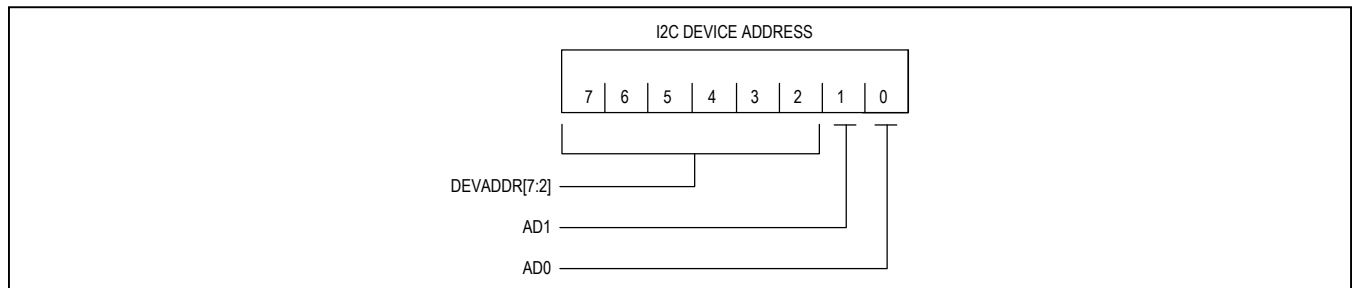

Figure 23. I2C Device Address Configuration

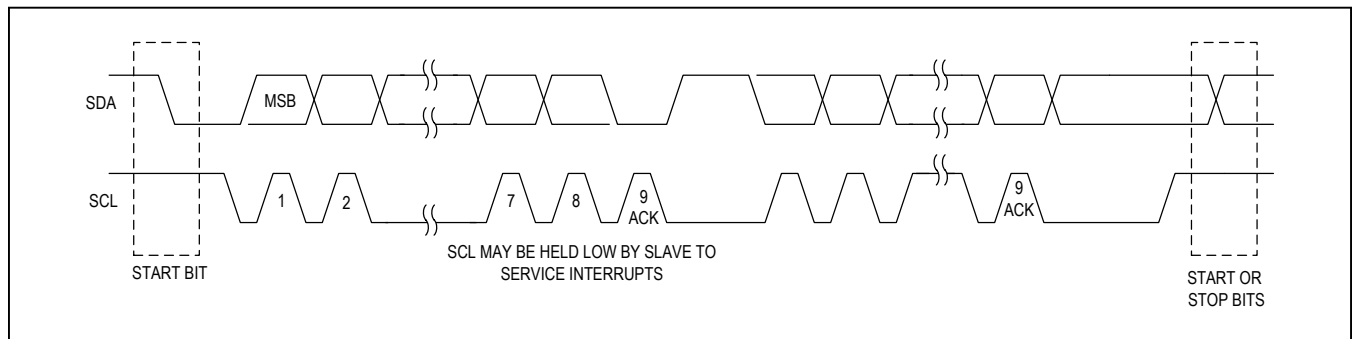

Figure 24. I2C Data Transfer

Device Addressing

A control byte is the first byte received following the START condition from the master device.

The control byte consists of a seven bit address and a bit (LSB) indicating the type of access (0 = write; 1 = read).

Write Operations

Following the START (S) condition from the master, the device address (7 bits) and the R/W bit (logic-low for write) are clocked onto the bus by the master. This indicates to the addressed slave receiver that the register address will follow after it has generated an acknowledge bit (A) during the ninth clock cycle. Therefore, the next byte transmitted by the master is the register address and will be written into the address pointer of the MAX78615+PPM. After receiving another acknowledge (A) signal from the MAX78615+PPM, the master device transmits the data byte(s) to be written into the addressed memory location. The data transfer ends when the master generates a stop (P) condition. This initiates the internal write cycle. [Figure 26](#) shows a 3-byte data write (24-bit register write).

Upon receiving a STOP (P) condition, the internal register address pointer will be incremented. The write access can be extended to multiple sequential registers. [Figure 27](#) shows a single transaction with multiple registers written sequentially.

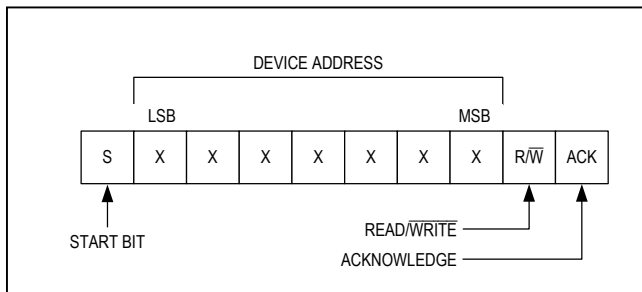

Figure 25. I²C Device Address

Read Operations

Read operations are initiated in the same way as write operations with the exception that the R/W bit of the control byte is set to one. There are two basic types of read operations: current address read and random read.

Current Address Read: The MAX78615+PPM contains an address counter that maintains the address of the last register accessed, internally incremented by one when the stop bit is received. Therefore, if the previous read access was to register address n, the next current address read operation would access data from address n + 1.

Upon receipt of the control byte with R/W bit set to one, the MAX78615+PPM issues an acknowledge (A) and transmits the eight bit data byte. The master does not acknowledge the transfer, but generates a STOP condition to end the transfer and the MAX78615+PPM discontinues the transmission.

This read operation is not limited to 3 bytes, but can be extended until the register address pointer reaches its maximum value. If the register address pointer has not been set by previous operations, it is necessary to set it issuing a command as follows:

Random Read: Random read operations allow the master to access any register in a random manner. To perform this operation, the register address must be set as part of the write operation. After the address is sent, the master generates a start condition following the acknowledge response. This sequence completes the write operation. The master should issue the control byte again this time, with the R/W bit set to 1 to indicate a read operation. The MAX78615+PPM issues the acknowledge response, and transmits the data. At the end of the transaction, the master does not acknowledge the transfer and generates a STOP condition.

This read operation is not limited to 3 bytes, but can be extended until the register address pointer reaches its maximum value.

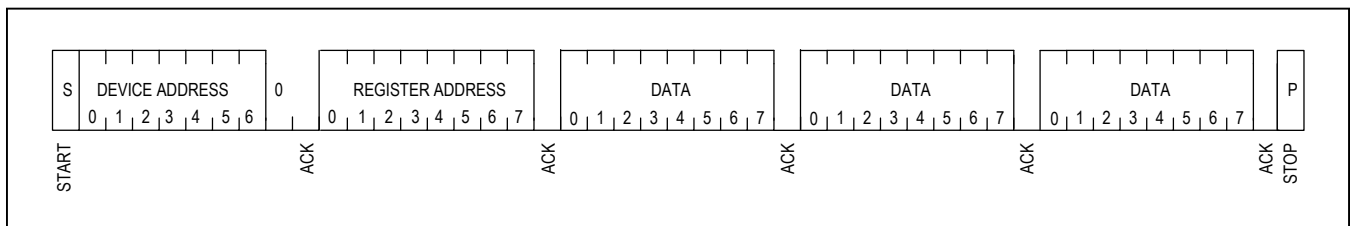

Figure 26. 3-Byte Data Write (24-Bit Register Write)

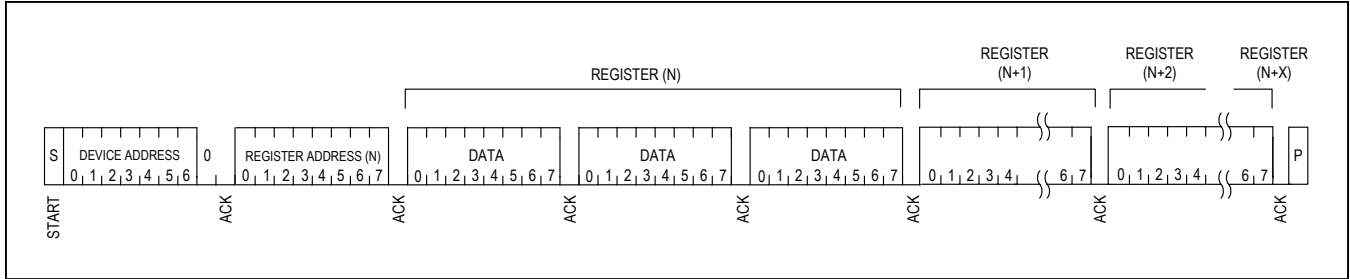

Figure 27. Single Transaction with Multiple Registers

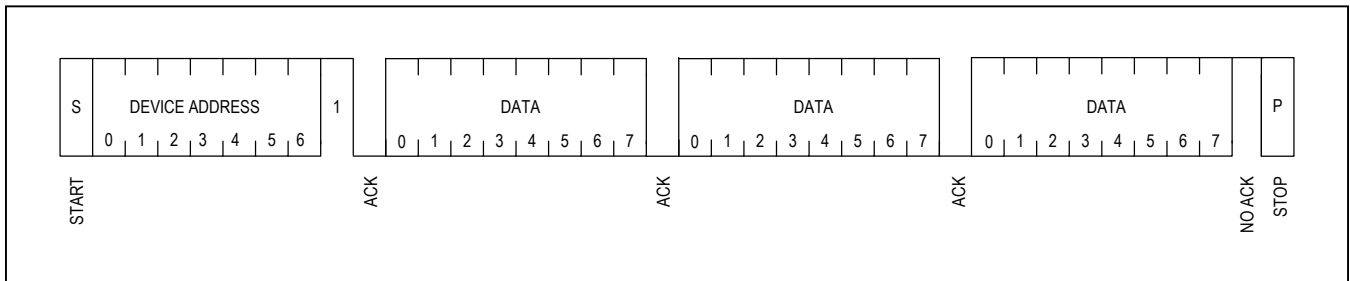

Figure 28. Register Read Transaction

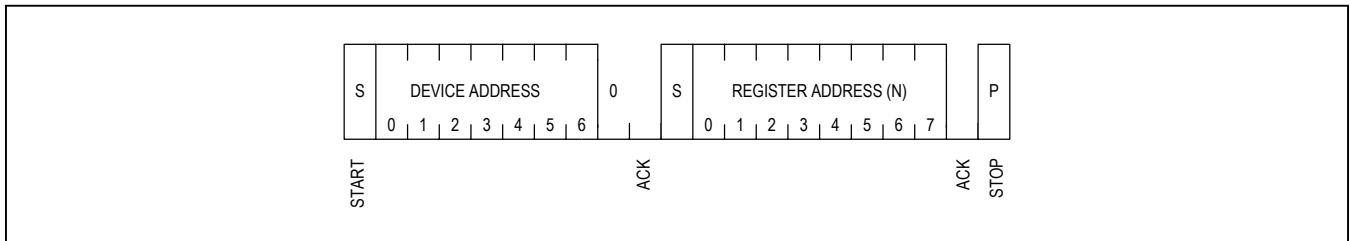

Figure 29. Register Address Command

Ordering Information

PART	TEMP RANGE	PIN-PACKAGE	TOP MARK	ISOLATED AFE
MAX78615+PPM/A03	-40°C to +85°C	24 TQFN-EP*		MAX78700
MAX78615+PPM/A03T				
MAX78615+PPM/C01				MAX71071
MAX78615+PPM/C01T				

+Denotes a lead(Pb)-free/RoHS-compliant package.

T = Tape and reel.

*EP = Exposed pad.

YY = Last two digits of year of assembly.

WW = Week of assembly.

RRRR = Die rev code from reliability database.

= Last 3 numeric characters from the lot number.

@@ = First two alpha characters after the numeric characters from the lot number.

Package Information

For the latest package outline information and land patterns (footprints), go to www.maximintegrated.com/packages. Note that a "+", "#", or "-" in the package code indicates RoHS status only. Package drawings may show a different suffix character, but the drawing pertains to the package regardless of RoHS status.

PACKAGE TYPE	PACKAGE CODE	OUTLINE NO.	LAND PATTERN NO.
24 TQFN-EP	T2444+4	21-0139	90-0022

Revision History

REVISION NUMBER	REVISION DATE	DESCRIPTION	PAGES CHANGED
0	3/15	Initial release	—

For pricing, delivery, and ordering information, please contact Maxim Direct at 1-888-629-4642, or visit Maxim Integrated's website at www.maximintegrated.com.

Maxim Integrated cannot assume responsibility for use of any circuitry other than circuitry entirely embodied in a Maxim Integrated product. No circuit patent licenses are implied. Maxim Integrated reserves the right to change the circuitry and specifications without notice at any time. The parametric values (min and max limits) shown in the Electrical Characteristics table are guaranteed. Other parametric values quoted in this data sheet are provided for guidance.