



SINGLE PHASE GLASS PASSIVATED BRIDGE RECTIFIER MB2M ~ MB10M

Single Phase Glass Passivated Bridge Rectifier

Features

- UL recognized under File #E197450
- Glass passivated chip junction
- High forward surge current capability
- High temperature soldering guaranteed:
260°C/10 seconds
- RoHS and REACH Compliance

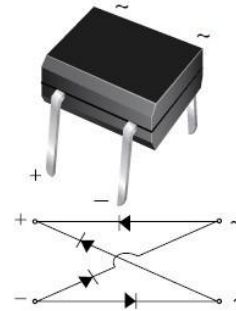

Case Style MBM

Mechanical Data

Case:	Transfer molded plastic
Polarity	Polarity symbols marked on case
Terminals:	Plated Leads solderable per MIL-STD-750 method 2026
Mounting torque	/
Mounting position:	Any
Weight:	0.0078 ounce, 0.22 gram

Maximum Ratings ($T_{Ambient}=25^{\circ}C$ unless noted otherwise)

Symbol	Description	MB2M	MB4M	MB6M	MB8M	MB10M	Unit	Conditions
VRRM	Max Recurrent Peak Reverse Voltage	200	400	600	800	1000	V	
VRMS	Max RMS Voltage	140	280	420	560	700	V	
VDC	Max DC Blocking Voltage	200	400	600	800	1000	V	
I(AV)	Max Average Forward Rectified Current	0.5/0.8					A	@TA=30°C On Glass-epoxy PCB (note1) On Aluminum substrate (Note2)
IFSM	Peak Forward Surge Current	30					A	8.3ms single half sine-wave (JEDEC method)
TJ,TSTG	Operating and Storage Temperature Range	-55 to +150					°C	
I2t	Rating for Fusing	5					A2s	T<8.3mS

Electrical Characteristics ($T_{Ambient}=25^{\circ}C$ unless noted otherwise)

Symbol	Description	MB2M	MB4M	MB6M	MB8M	MB10M	Unit	Conditions
VF	Max Instantaneous Forward Voltage	1.00					V	Drop per Bridge element 0.4A
IR	Max DC Reverse Current at Rated DC Blocking Voltage	5.0					µA	TA=25°C
		100						Tc=125°C
Rθ-Ja	Typical Thermal Resistance	85					°C/W	Note 1
Cj	Typical Junction capacitance per leg	13					pF	Measured at 1.0MHz/4.0V

Note:

1. On glass epoxy PCB mounted on 0.05" x 0.05" (1.3mm x 1.3mm) copper pads
2. On aluminum substrate PCB with an area of 0.8" x 0.8" x 0.25" (20mm x 20mm x 6.4mm) mounted on 0.05" x 0.05" (1.3mm x 1.3mm) solder pad

MB2M ~ MB10M

RATINGS AND CHARACTERISTIC CURVES MB2M THRU MB10M

TYPICAL INSTANTANEOUS FORWARD CHARACTERISTICS

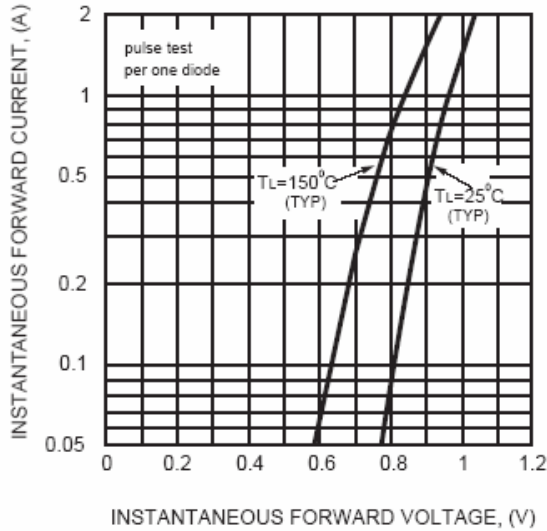

POWER DISSIPATION

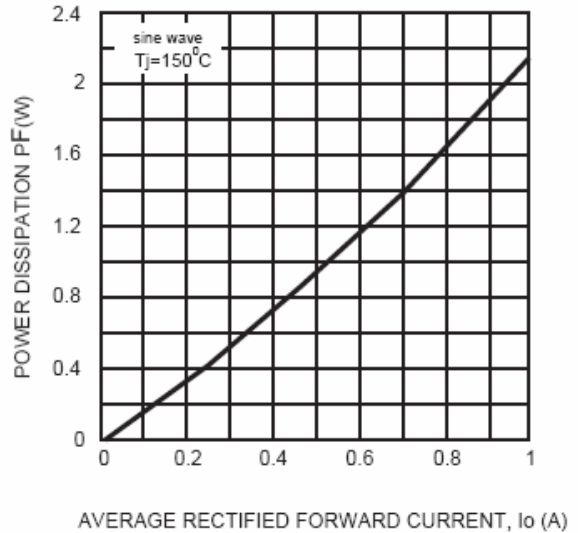

SURGE FORWARD CURRENT CAPABILITY

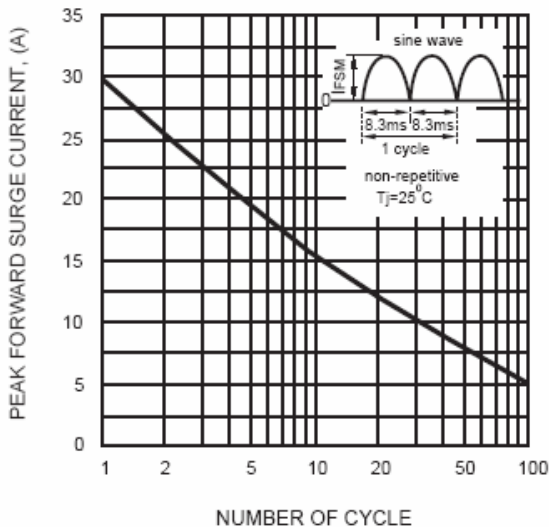

TYPICAL FORWARD CURRENT DERATING CURVE

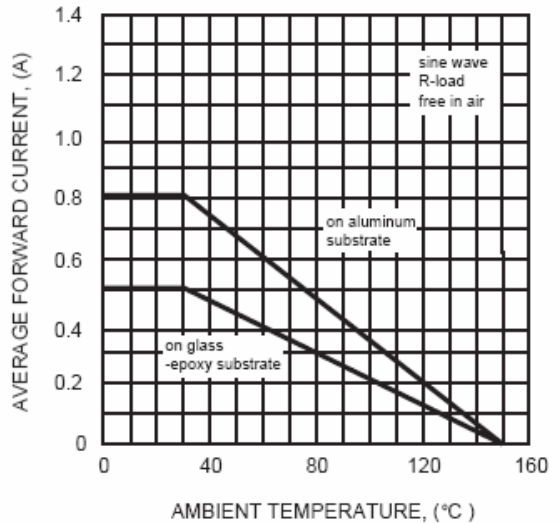

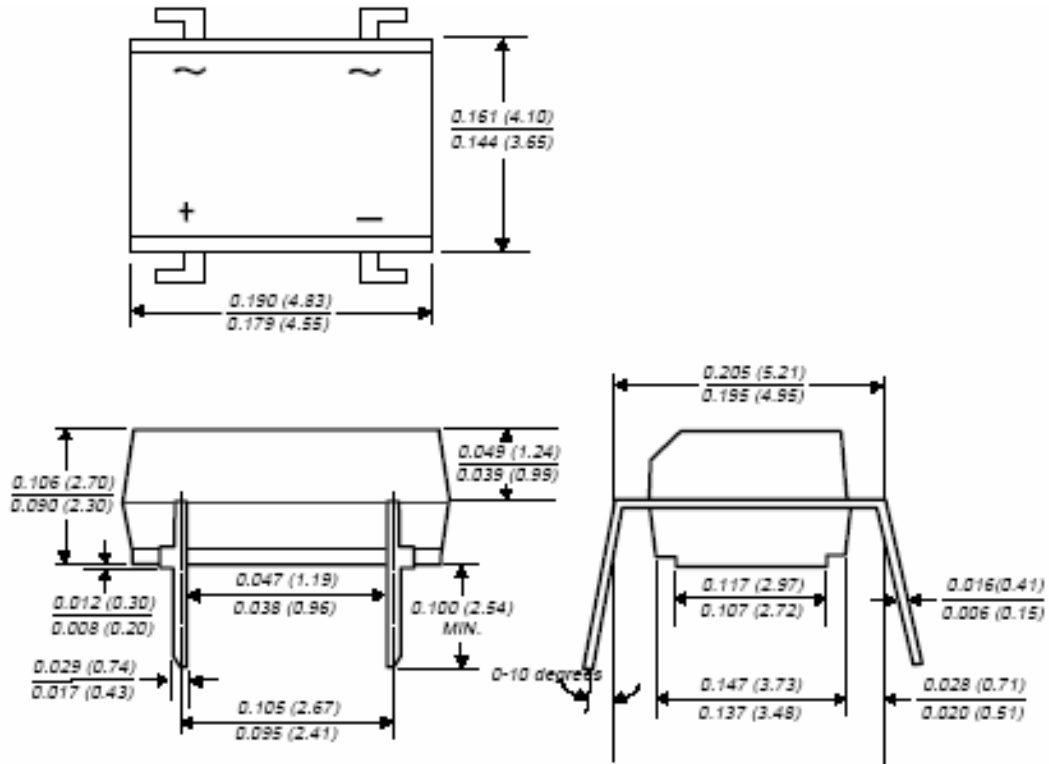
Dimensions in inches (mm)

Contact us:
US HEADQUARTERS
MEI SEMI INC.
2902 Corvin Drive, Santa Clara, CA95051, USA

Tel: 1-408-733-0808 Fax: 1-408-733-2828