

MB1F THRU MB10F

Surface Mount Glass Passivated Bridge Rectifier
Reverse Voltage - 50 to 1000 V
Forward Current - 1 A

Features

- Glass passivated chip junction
- High Surge Current Capability
- Designed for Surface Mount Application

Mechanical Data

- Case: Molded plastic, MBF
- Terminals: solderable per MIL-STD-750, Method 2026

PINNING

PIN	DESCRIPTION
1	Input Pin (~)
2	Input Pin (~)
3	Output Anode (+)
4	Output Cathode (-)

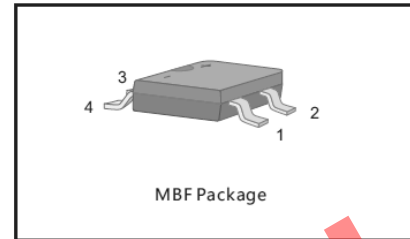

Absolute Maximum Ratings and Characteristics

Ratings at 25 °C ambient temperature unless otherwise specified. Single phase, half wave, 60 Hz, resistive or inductive load. For capacitive load, derate current by 20%.

Parameter	Symbols	MB1F	MB2F	MB4F	MB6F	MB8F	MB10F	Units
Maximum Recurrent Peak Reverse Voltage	V_{RRM}	100	200	400	600	800	1000	V
Maximum RMS Voltage	V_{RMS}	70	140	280	420	560	700	V
Maximum DC Blocking Voltage	V_{DC}	100	200	400	600	800	1000	V
Average Rectified Output Current at $T_a = 40^\circ\text{C}$	$I_{F(AV)}$	1						A
Peak Forward Surge Current 8.3 ms Single Half-sine-wave Superimposed on Rated Load (JEDEC Method)	I_{FSM}	30						A
Maximum Forward Voltage at 1 A	V_F	1						V
Maximum DC Reverse Current at $T_a = 25^\circ\text{C}$ at Rated DC Blocking Voltage at $T_a = 125^\circ\text{C}$	I_R	5 100						μA
Typical Junction Capacitance ¹⁾	C_J	13						pF
Typical Thermal Resistance ²⁾	$R_{\theta JA}$ $R_{\theta JL}$	60 16						$^\circ\text{C/W}$
Operating and Storage Temperature Range	T_j, T_{stg}	- 55 to + 150						$^\circ\text{C}$

¹⁾ Measured at 1 MHz and applied reverse voltage of 4 V

²⁾ On glass epoxy P.C.B. mounted on 0.05" X 0.05" (1.3 X1.3 mm) pads

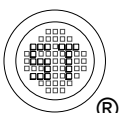

SEMTECH ELECTRONICS LTD.



ISO 9001 : 2008
Certificate No. 50719410



ISO 14001 : 2004
Certificate No. 7116



BS-OHSAS 18001 : 2007
Certificate No. 7116



IECQ QC 080000
Certificate No. PRC-HSPM-1483-1



SGS



TOP DYNAMIC ENTERPRISES LTD.

Dated 23/07/2014 NY Rev: 01

MB1F THRU MB10F

Fig.1 Average Rectified Output Current Derating Curve

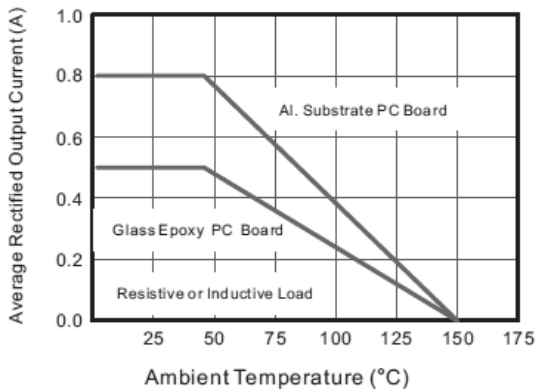

Fig.2 Typical Reverse Characteristics

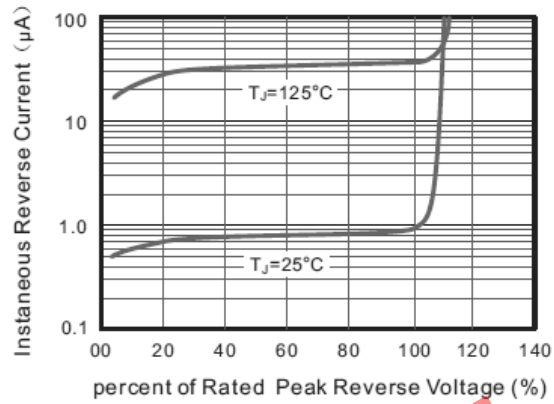

Fig.3 Typical Instantaneous Forward Characteristics

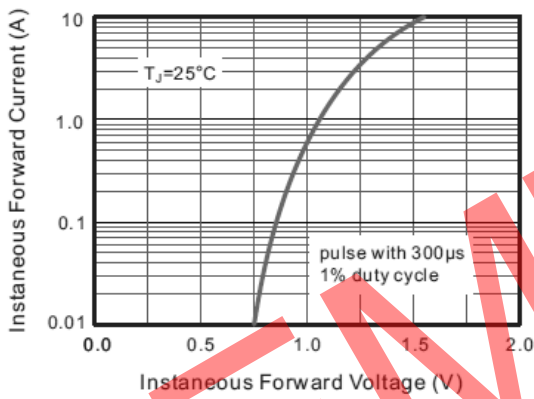

Fig.4 Typical Junction Capacitance

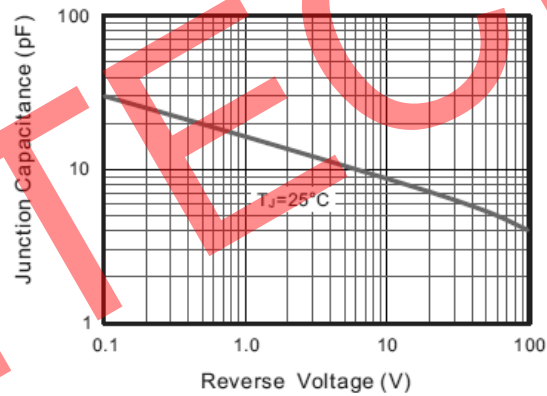
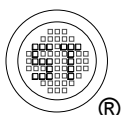
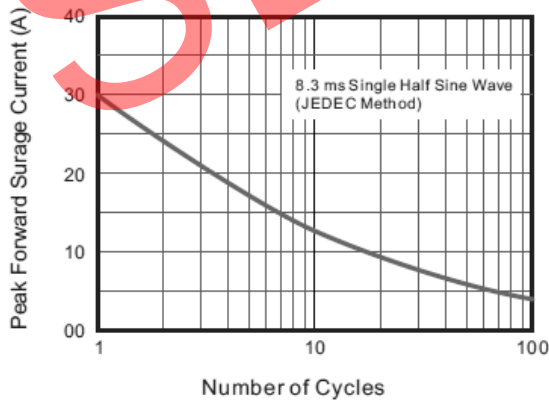

Fig.5 Maximum Non-Repetitive Peak Forward Surge Current



MB1F THRU MB10F

PACKAGE OUTLINE

MBF

Plastic surface mounted package; 4 leads

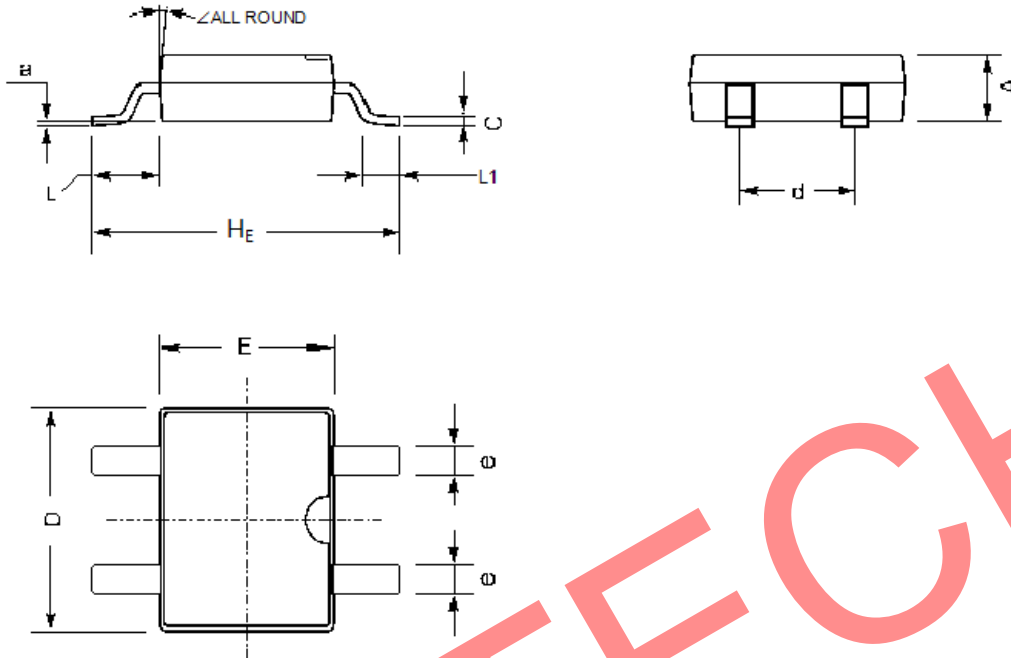

UNIT	A	C	D	E	H _E	d	e	L	L1	a	∠
mm	1.45	0.22	4.75	4.00	6.85	2.65	0.80	1.70	1.10	0.15	7°
	1.30	0.18	4.45	3.50	6.55	2.35	0.60	1.30	0.85	0.00	

RECOMMENDED SOLDERING FOOTPRINT

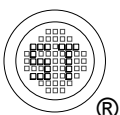
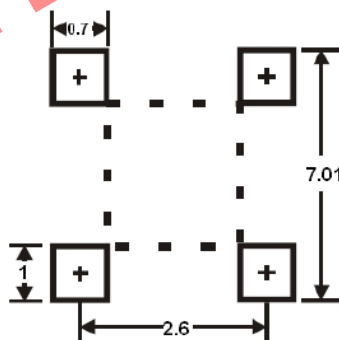

SEMTECH ELECTRONICS LTD.



ISO 9001 : 2008
Certificate No. 100713000



ISO 14001 : 2004
Certificate No. 7116



ISO 9001 : 2008
Certificate No. 50719410



BS-OHSAS 18001 : 2007
Certificate No. 7116



IECQ QC 080000
Certificate No. PRC-HSPM-1483-1



TOP DYNAMIC ENTERPRISES LTD.

Dated 23/07/2014 NY Rev: 01