

MB43458

T-73-13-03



Quad Pre-amplifier IC
for
Vertex Time Projection Chamber Sensor

July 1984
DSTV84-062

The Fujitsu MB43458 is a quad preamplifier IC designed for Vertex Time Projection Chamber Sensor by Fujitsu

BLOCK DIAGRAM

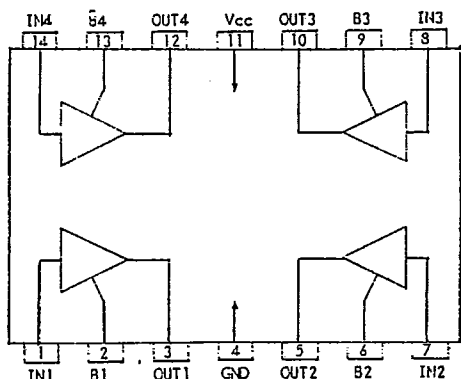

EQUIVALENT CIRCUIT (One Channel)

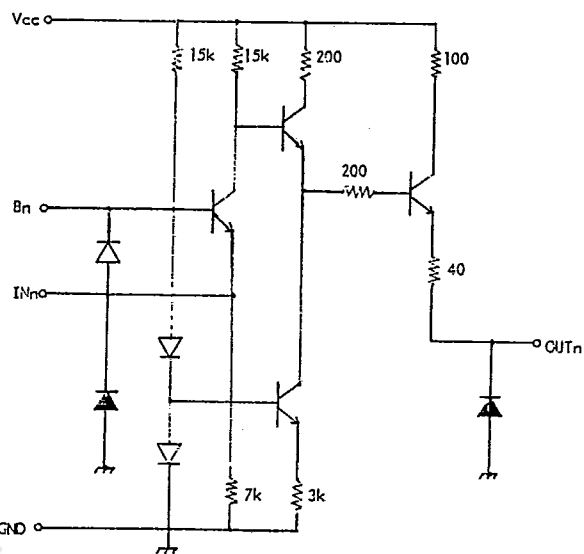

PIN ASSIGNMENT
(TOP VIEW)

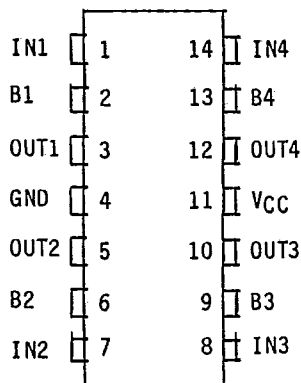

Note: : Protection Diode

Where n is 1, 2, 3 and 4.

ABSOLUTE MAXIMUM RATINGS ($T_A=25^\circ\text{C}$)

Parameter	Symbol	Rating	Unit
Power Supply Voltage	VCC	16	V
Power Dissipation	P _D *	280 (at $T_A < 75^\circ\text{C}$)	mW
Operating Ambient Temperature	T _A	-20 to +75	°C
Storage Temperature	T _{STG}	-55 to +125	°C

Note : * Mounted on 5 x 5 cm² ceramic board.

RECOMMENDED OPERATING CONDITIONS

Parameter	Symbol	Value			Unit
		Min.	Typ.	Max.	
Power Supply Voltage	VCC	11.5	12.0	12.5	V
Operating Ambient Temperature	T _A	-20	+25	+75	°C

ELECTRICAL CHARACTERISTICS ($T_A=25^\circ\text{C}, V_{CC}=12\text{V}, R_S=680\Omega$)

Parameter	Conditions	Symbol	Value			Unit
			Min.	Typ.	Max.	
Input Voltage	See Fig.1	V _{IN}	1.8	2.2	2.6	V
Output Voltage	See Fig.1	V _{OUT}	4.7	5.7	6.7	V
Bias Voltage	See Fig.1	V _B	2.5	2.9	3.3	V
Supply Current	See Fig.1	I _{CC}	12	16	21	mA
	See Fig.2	1/gm	6.4	7.2	8.0	mV/ μA
	See Fig.2	$\Delta 1/\text{gm}$	94	100		%
Noise Voltage	f _q =1MHz, C _{in} =25pF See Fig.3			20		nV/ $\sqrt{\text{Hz}}$

8

T-73-13-03

Impulse Noise Characteristics

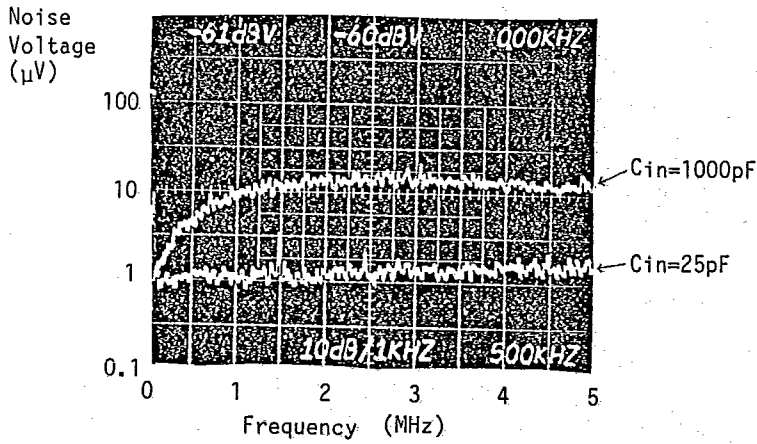

Random Noise Characteristics

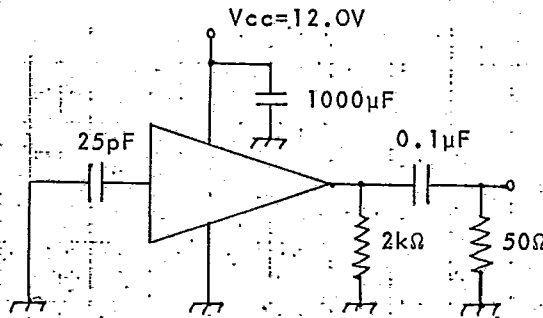
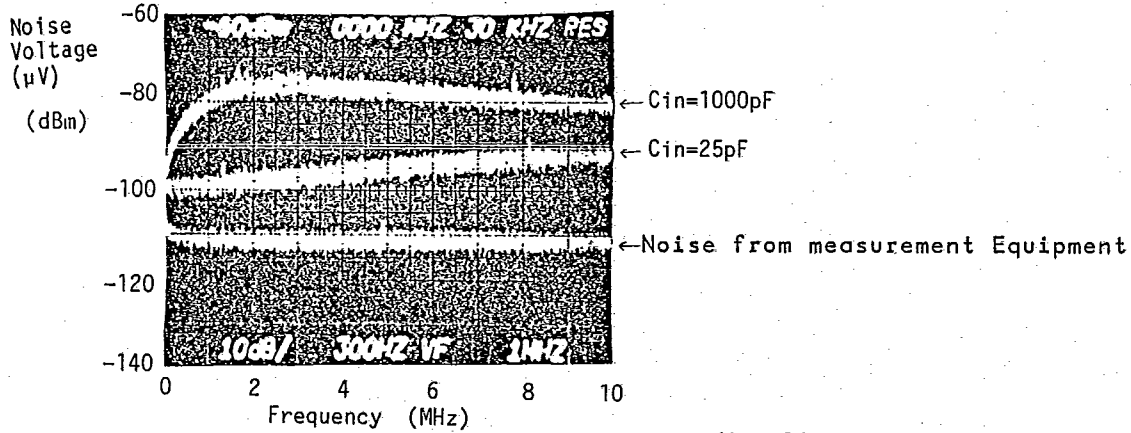

T-73-13-03

Fig.1

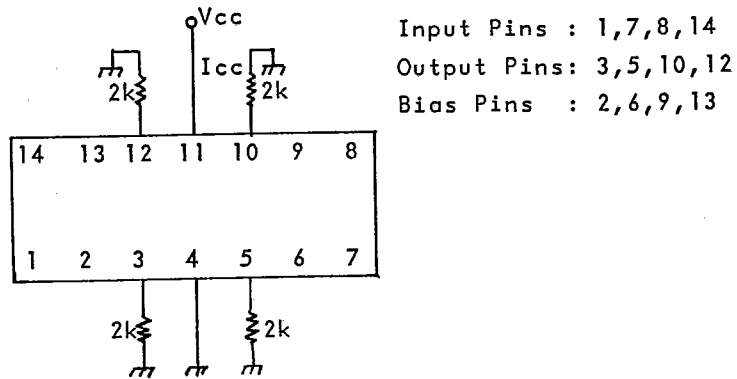

Fig.2

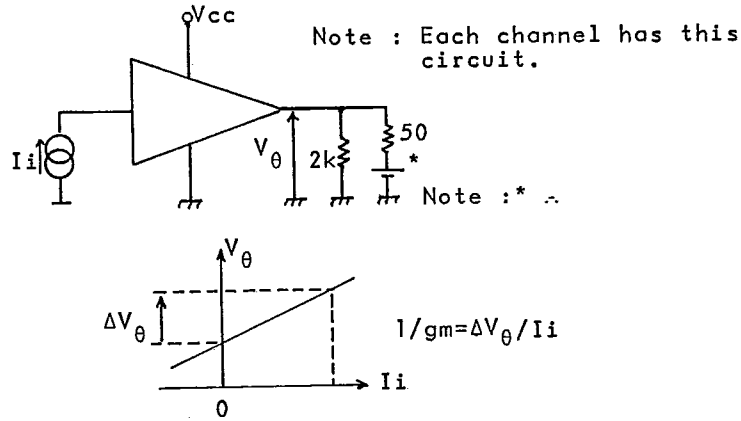
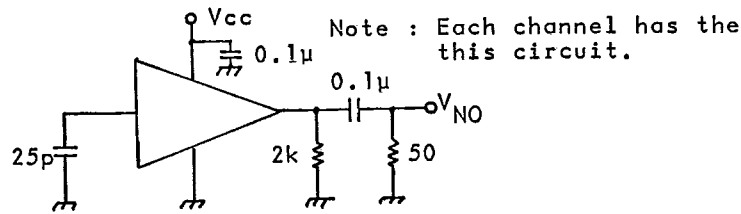
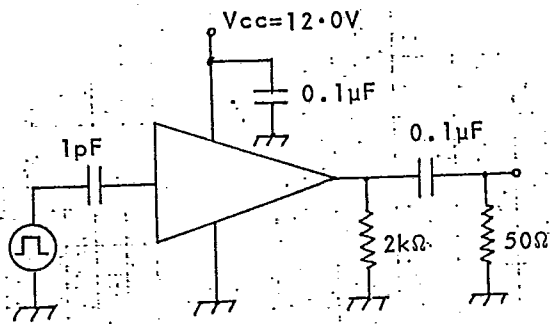
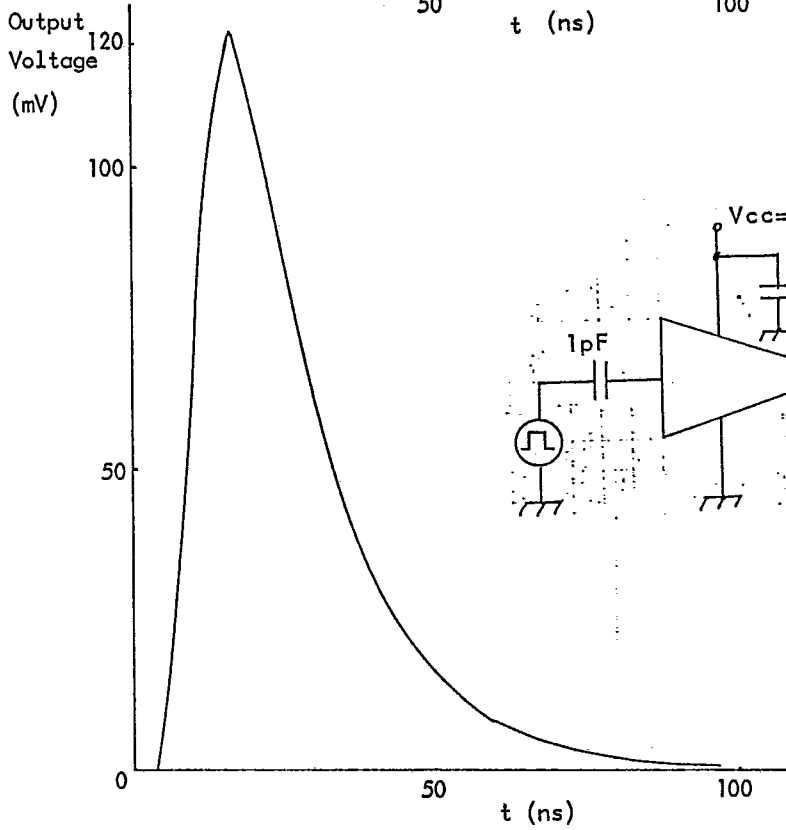
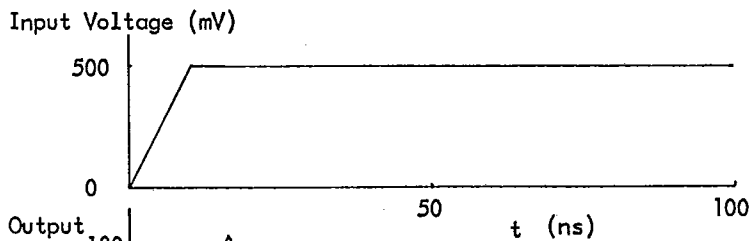

Fig.3





8

T-73-13-03

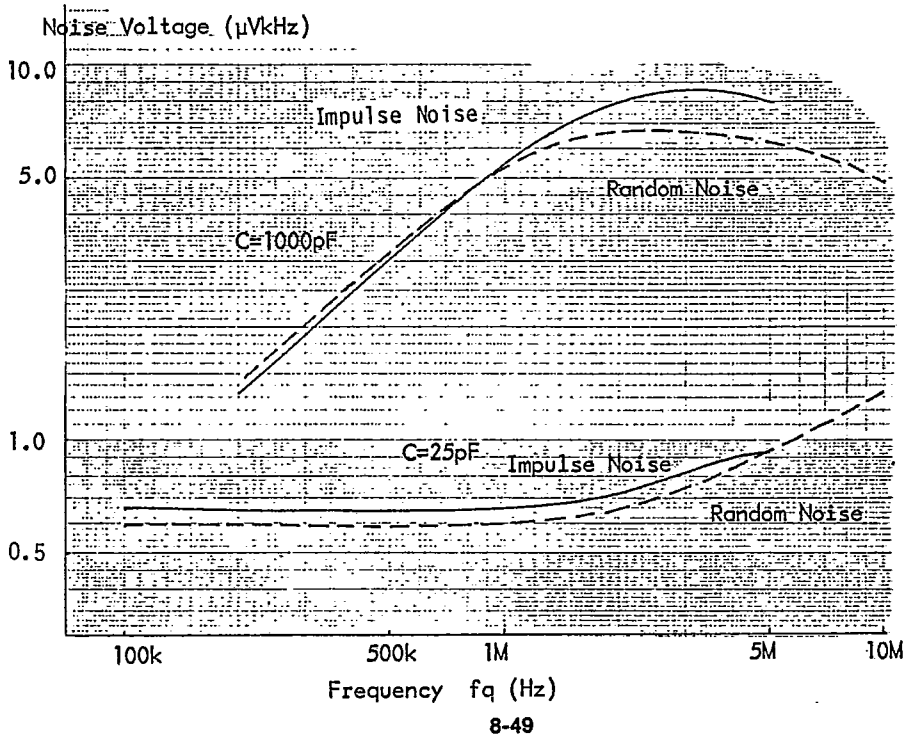
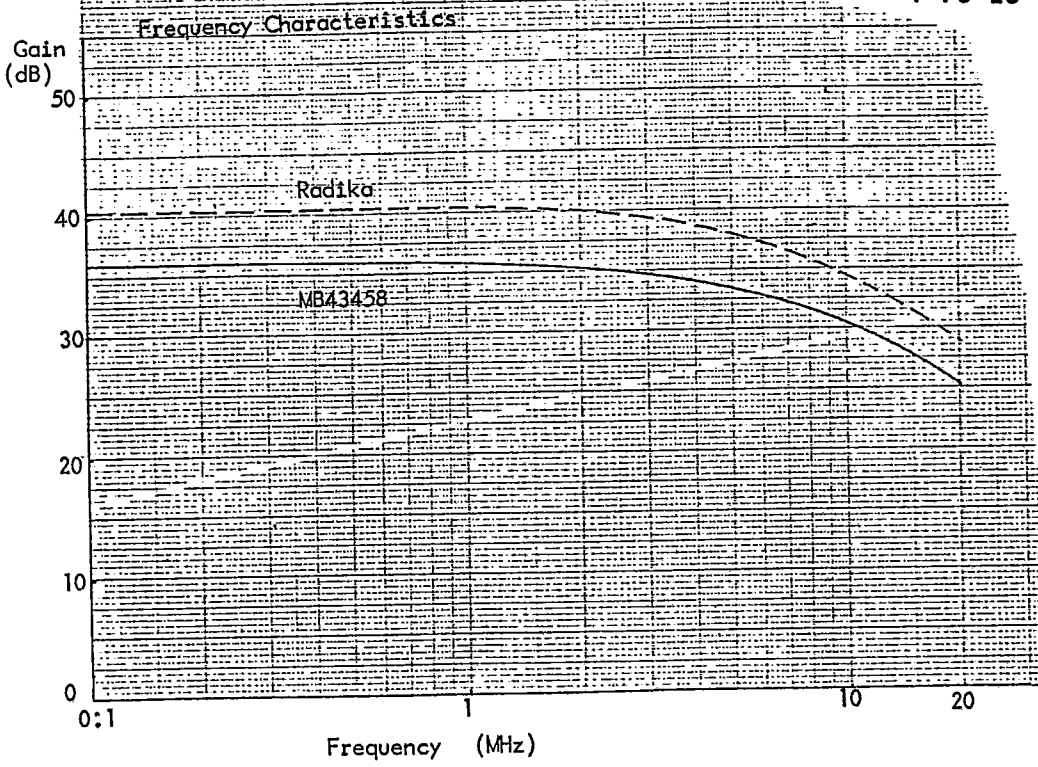

8

14-LEAD PLASTIC FLAT PACKAGE
(CASE No.: FPT-14P-M01)

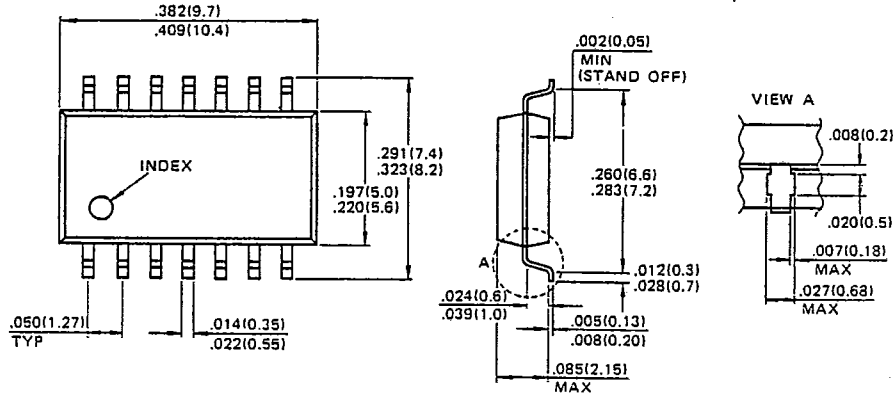

© 1986 FUJITSU LIMITED F14003S-1C

8