



MB86C30-REBFUN-E

*MB86C30 Reference board
Function Specification*

Rev1.6 September 24, 2009

Fujitsu Microelectronics Limited.

Revised History

Revision	DATE	Revised content
1.0	2009/06/03	First created
1.6	2009/09/17	Reflect "MB86C30 Errata Sheet Rev1.3" , etc

Contents

1. INTRODUCTION	4
2. OVERVIEW OF BOARD	4
2-1. FUNCTION	4
2-2. BLOCK DIAGRAM	5
2-3. PARTS PLACEMENT	5
3. MAIN PARTS LIST	6
4. OVERVIEW OF CIRCUIT	7
5. SWITCH,JUMPER,LED FUNCTION TABLE	8
5-1. SWITCH	8
5-2. JUMPER.....	8
5-3. LED.....	9
6. CONNECTOR PIN ASSIGNMENT	10
7. USAGE PRECAUTIONS.....	12
7-1. USB3.0-IF	12
7-2. USB2.0-IF	12
7-3. CLOCK.....	12
7-4. NMSEL	12
7-5. HDD POWER SUPPLY	13
7-6. DEFAULT SETTING	13

1. Introduction

This document describes a function specification of the reference board for MB86C30 (USB3.0-SATA bridge) developed by Fujitsu Microelectronics Ltd.

【Related documentation】

MB86C30 DATA SHEET
MB86C30 User's Manual
Universal Serial Bus 3.0 Specification Revision1.0

Fujitsu Microelectronics Limited
Fujitsu Microelectronics Limited
Hewlett-Packard Company,
Intel Corporation,
Microsoft Corporation,
NEC Corporation,
ST-NXP Wireless,
Texas Instruments

2. Overview of board

2-1. Function

MB86C30 Reference board has following functions.

- MB86C30 (USB3.0-SATA bridg chip) embedded.
- One Standard-B receptacle is embedded for USB3.0 interface.
SuperSpeed(5Gbps)/High-Speed(480Mbps)
- One COMBO receptacle is embedded for SATAinterface
SATA Gen2(3Gbps)/Gen1(1.5Gbps)
- SPI-Flash 512Kbit is embedded for external memory.
- The power supply supports two ways of supply methods of USB bus power and the self-power.
(Peripheral Power Connector)
- As for the USB bus power and self-power, achange is possible with a jumper.

2-2. Block diagram

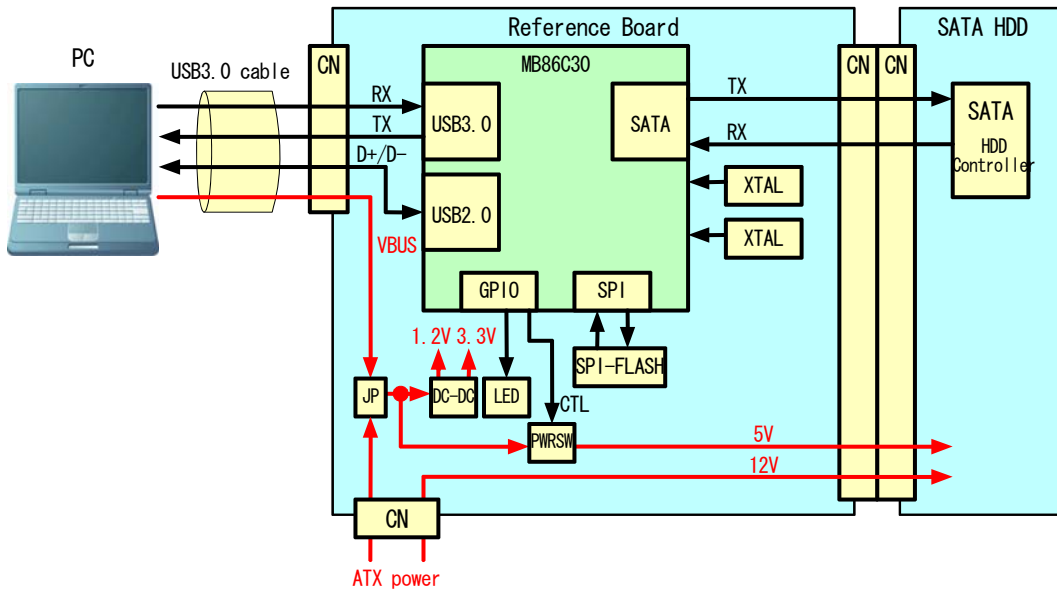

2-3. Parts placement

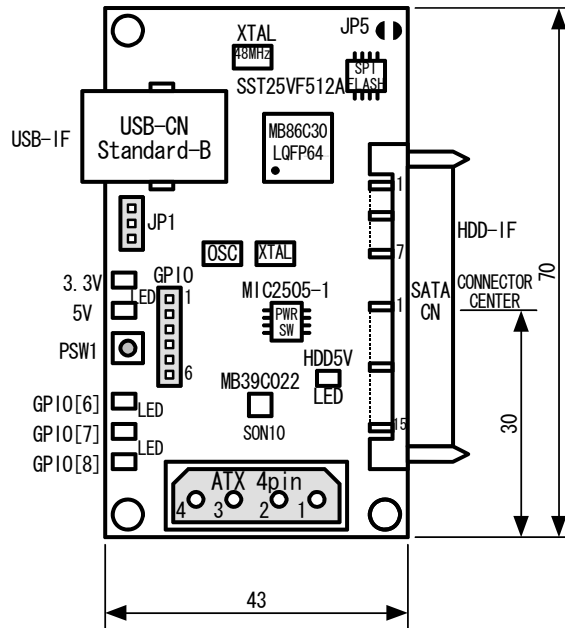

3. Main parts list

Item	Maker	Type	Num	Pow	Note
ASSP	FML	MB86C30	1	3.3V 1.2V	USB3.0-SATA bridge LQFP64 0.4pitch
DC-DC	FML	MB39C022G	1	5V	DC-DC:600mA/LDO:300mA SON10 5V->3.3V/1.2V
FLASH	SST	SST25VF512A-33-4C-SAE	1	3.3V	SPI-FLASH 512kbit SOP8
ESD	MURATA	LXES4XBAA6-027	1	5.0V	1-line ESD Protection Array SOP8 0.65pitch
ESD	MURATA	LXES15AAA1-017	6	---	1-line ESD Protection device SMD (1005)
FL	MURATA	DLP11TB000UL2 for USB3.0	2	---	USB3.0 common mode choke 1.25x1.0 SMD
PWR-SW	MICREL	MIC2505-1YM	1	5.0V	1ch/2A switch(Act-High) SOP8 1.27pitch
IC	TI	SN74LVC3G14DCU	1	3.3V	Triple Schmitt-trigger inverter VSSOP8
IC	TI	SN74LVC1G08DRL	1	3.3V	Single 2-input AND SOT-553
FET	---	FDV301N	1	---	NMOSFET SOT-23
FET	---	BSS84	1	---	PMOSFET SOT-23
OSC	NIHON DENPA	2725T 50MHz or 25MHz	1	3.3V	50MHz or 25MHz SMD MB86C30(SYSCLK)
Crystal	NIHON DENPA	NX5032G STD-CKW-3 (50MHz) or STD-CSK-4 (25MHz)	1	3.3V	50MHz or 25MHz SMD MB86C30(SYS_XI/XO)
Crystal	NIHON DENPA	NX5032G STD-CSK-4 (48MHz)	1	3.3V	48MHz SMD MB86C30(U2_XI/XO)
LED	ROHM	SML-310MT	6	---	LED Green SMD
Switch	ALPS	SKRPABE010	1	---	Push Switch MB86C30(GPIO[5])
Connector	FOXCONN	UEB11123-2AK1-4H_327-0000-2014_X1	1	---	USB3.0 Standard-B right-angle
Connector	FCI	10034814-001LF	1	---	SATA COMBO right angle socket SMT 1.27pitch
Connector	MOLEX	15-24-4557	1	---	4pin x 1 ATX peripheral power 5.08pitch
Connector	MAC8	WL-1-3P	1	---	3pin x 1 straight pin header 2.54pitch Jumper
Connector	MAC8	WL-1-6P	1	---	6pin x 1 straight pin header 2.54pitch GPIO
Cable	FOXCONN	USB3.0 Standard-A to Standard-B	--	---	USB3.0 Std-A plug to Std-B plug

4. Overview of circuit

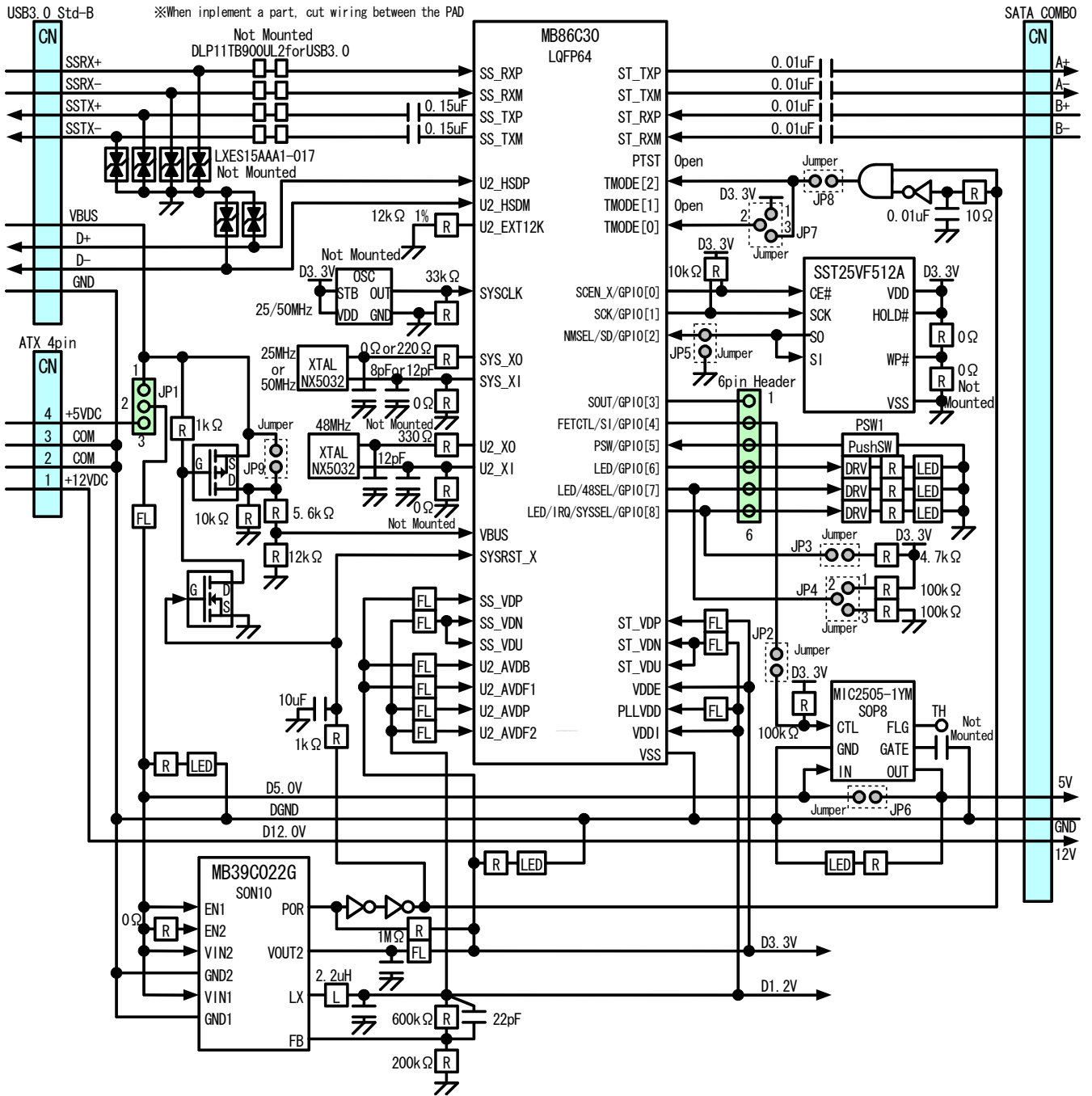

5. Switch, Jumper, LED function table

5-1. Switch

PSW1 : MB86C30 setting (GPIO[5])		Push button switch
Function	Condition	Setting content
Reserved	ON(push-down) : L	Function depends on a deployment program to MB86C30
	OFF : H	Normal condition

5-2. Jumper

JP1 : Power setting		Jumper (Pin header)
Function	Setting	Setting content
Board power supply	SHORT 1-2	USB VBUS by a board power supply (USB bus power)
	SHORT 2-3	ATX connector input by a board power supply (Self power)
<ul style="list-style-type: none"> The DC12V supply to the SATA HDD becomes it only in an ATX power supply. 		

JP2 : HDD-5V Power control setting		Jumper (Solder pad)
Function	Setting	Setting content
HDD-5V power control	SHORT	Control it in GPIO[4] (High : 5V-ON Low : 5V-OFF)
	OPEN	HDD-5V are always ON

JP3 : System clock setting		Jumper (Solder pad)
Function	Setting	Setting content
Select system clock frequency	SHORT	50MHz mode (SYSCLK or SYS_XI/XO)
	OPEN	25MHz mode (SYSCLK or SYS_XI/XO)
<ul style="list-style-type: none"> When you use SYSCLK, please short2-3 JP7, and please implement an oscillator in U4. When you use SYS_XI/XO, please short1-2 JP7, please remove R9, and please implement crystal in X1. 		

JP4 : USB2.0 clock setting		Jumper (Solder pad)
Function	Setting	Setting content
Select USB2.0 clock	SHORT 1-2	Crystal mode (U2_XI/XO)
	SHORT 2-3	Internal clock mode (Generates it than system clock)
<ul style="list-style-type: none"> When you use U2_XI/XO, please implement 48MHz crystal in X2. 		

JP5 : MB86C30 boot setting		Jumper
Function	Setting	Setting content
Select MB86C30 boot mode	OPEN	Normal condition
	Short-circuit at power-up (1~2sec)	Maintenance mode

JP6 : HDD-5V Power supply setting		Jumper (Solder pad)
Function	Setting	Setting content
HDD-5Vsupply	OPEN	Normal condition
	SHORT	Please do not set it
<ul style="list-style-type: none"> When you let you short-circuit, please remove U3 (MIC2505-1YM). 		

JP7 : System clock setting		Jumper (Solder pad)
Function	Setting	Setting content
Select System base clock	SHORT 1-2	Crystal mode (X1 : SYS_XI/SYS_XO)
	SHORT 2-3	Oscillator mode (U4 : SYSCLK)
<ul style="list-style-type: none"> • When you use SYS_XI/SYS_XO, please implement crystal in X1. (NX5032GA 50MHz or 25MHz) • When you use SYSCLK, please implement oscillator in U4. (2725T 50MHz or 25MHz) 		

JP8 : MB86C30 device setting		Jumper (Solder pad)
Function	Setting	Setting content
Select MB86C30	OPEN	Assembly to ES2 and later
	SHORT	Assembly to ES1

JP9 : MB86C30 device setting		Jumper (Solder pad)
Function	Setting	Setting content
Select VBUS control	OPEN	Assembly to ES1
	SHORT	Assembly to ES2 and later

5-3. LED

Part name	Function	Color	Polarity	Content
D1	5V power monitor	Green	--	Lighting 5V power ON
D2	3.3V power monitor	Green	--	Lighting 3.3V power ON
D3	HDD-5V power monitor	Green	--	Lighting SATA-5V power ON
D4	GPIO[6] monitor	Green	H	
D5	GPIO[7] monitor	Green	H	
D6	GPIO[8] monitor	Green	H	

6. Connector pin assignment

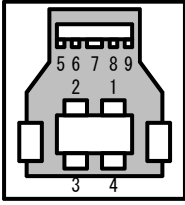

CN3 : USB connector (Standard-B)

Type	No	IO	Signal	Note
USB2.0	1	--	VBUS	VBUS 5.0V VBUS
	2	B	U2_HSDM	USB2.0 D- D-
	3	B	U2_HSDP	USB2.0 D+ D+
	4	--	DGND	Ground GND
USB3.0	5	O	SS_TXM	USB3.0 Super Speed TX- SSTX-
	6	O	SS_TXP	USB3.0 Super Speed TX+ SSTX+
	7	--	DGND	Ground GND
	8	I	SS_RXM	USB3.0 Super Speed RX- SSRX-
	9	I	SS_RXP	USB3.0 Super Speed RX+ SSRX+

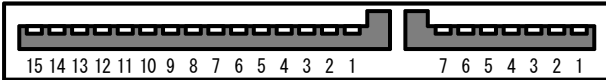

CN2 : SATA connector (COMBO)

Type	No	IO	Signal	Note
Signal	1	--	DGND	Ground 2nd GND
	2	O	ST_TXP	SATA HTX+ A+
	3	O	ST_TXM	SATA HTX- A-
	4	--	DGND	Ground 2nd GND
	5	I	ST_RXM	SATA HRX- B-
	6	I	ST_RXP	SATA HRX+ B+
	7	--	DGND	Ground 2nd GND
Power	1	--	N.C	DC3.3V 3rd 3.3V
	2	--	N.C	DC3.3V 3rd 3.3V
	3	--	N.C	DC3.3V 2nd 3.3V
	4	--	DGND	Ground 1st GND
	5	--	DGND	Ground 2nd GND
	6	--	DGND	Ground 2nd GND
	7	--	D5.0V	DC5.0V 2nd 5V
	8	--	D5.0V	DC5.0V 3rd 5V
	9	--	D5.0V	DC5.0V 3rd 5V
	10	--	DGND	Ground 2nd GND
	11	--	N.C	Device Activity / Disable Staggered Spin-up 3rd LED#
	12	--	DGND	Ground 1st GND
	13	--	D12V	DC12V When you connected an ATX power supply. 2nd 12V
	14	--	D12V	DC12V When you connected an ATX power supply. 3rd 12V
	15	--	D12V	DC12V When you connected an ATX power supply. 3rd 12V

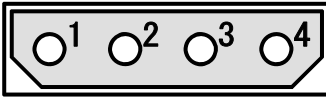
**CN1 : ATX power connector**

No	IO	Signal	Note
1	--	+12V	DC12.0V
2	--	DGND	Ground
3	--	DGND	Ground
4	--	+5V	DC5.0V

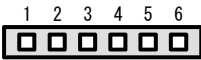
**CN4 : GPIO connector**

No	IO	Signal	Note
1	*	GPIO[3]/SOUT	33kΩ Internal pull-down
2	*	GPIO[4]/SI/FETCTL	33kΩ Internal pull-down Connected to CTL of U3(MIC2505-1)
3	*	GPIO[5]/PSW	33kΩ Internal pull-down Connected to PSW1(PushSW)
4	*	GPIO[6]/LED	33kΩ Internal pull-down Connected to D4(LED)
5	*	GPIO[7]/48SEL/LED	Connected to D5(LED)
6	*	GPIO[8]/SYSEL/IRQ/LED	33kΩ Internal pull-down Connected to D6(LED)

- GPIO[2:0] is used as SPI-FLASH interface.
- GPIO[2,7,8] is shared with a MB86C30 initial setting terminal in the power-up.
- GPIO[3,4] is shared with a UART terminal. (When you use UART, please prepare a RS232 transceiver outside.)
- GPIO[4] is shared with HDD-5V power supply control pin.
- GPIO[6,7,8] is shared with LED. (D4,D5,D6)

7. Usage precautions

7-1. USB3.0-IF

The reference board implements the following parts on a super-speed differential signal line for EMI/ESD correspondence. ~~But the common mode choke is connected between PAD at a line and examines whether you implement it individually. When you implement a common mode choke, You cut wiring between the PAD and implement a part.~~

ESD protection device : MURATA LXES15AAA1-017

~~Common mode choke : MURATA DLP11TB900UL2 for USB3.0~~

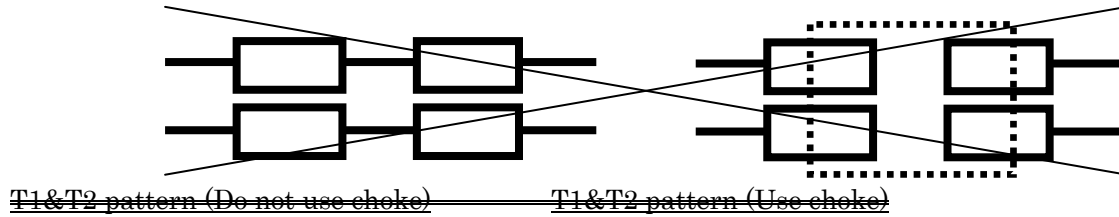

7-2. USB2.0-IF

The reference board implements the following parts on a high-speed differential signal line for ESD correspondence. But do not use the common mode choke.

ESD protection device : MURATA LXES15AAA1-017

7-3. Clock

The reference board makes all part implementation patterns to be able to confirm all clock methods of MB86C30. Please refer to list shown below for each usage.

【System clock】

Mode	Clock input	Frequency	JP3	JP7	Parts assembly					Note
					X1	C25,C26	R36	R9	U4	
Crystal	SYS_XI/XO	50MHz	SHORT	SHORT 1-2	Y (50MHz)	Y(12pF)	Y(220Ω)	N	N	NX5032G STD-CKW-3
		25MHz	OPEN	SHORT 1-2	Y (25MHz)	Y(8pF)	Y(0Ω)	N	N	NX5032G STD-CSK-4
Oscillator	SYSCLK	50MHz	SHORT	SHORT 2-3	N	N	N	Y	Y (50MHz)	2725T
		25MHz	OPEN	SHORT 2-3	N	N	N	Y	Y (25MHz)	2725T

【USB2.0 clock】

Mode	Clock input	Frequency	JP4	Parts assembly		Note
				X2	R11	
External Crystal	U2_XI/XO	48MHz	SHORT 1-2	Y (48MHz)	N	NX5032G STD-CSK-4
Internal	----	48MHz	SHORT 2-3	N	Y	

7-4. NMSEL

When you want to start MB86C30 with a maintenance mode, you make it an opening state after having let JP5 short-circuit at the time of power supply ON for 1 or 2 seconds. Please usually start JP5 as an open state. JP5 is top layer.(L1)

7-5. HDD Power supply

When you want to control 5V supply for HDD to the SATA connector, you let JP2 short-circuit, and please control it by a program from a GPIO[4] terminal of MB86C30.

In addition, the board makes JP6 to supply it without U3(MIC2505-1YM) for 5V supply control.

DC12V are always supplied at the time of ATX power supply connection.

【DC5V】

5V power	JP2	JP6	U3 assembly	GPIO[4]		Output	Note
				IO	Condition		
Program control	SHORT	OPEN	Y	Output	High	5V output	
					Low	Stop	
Always ON	OPEN	OPEN	Y	---	---	5V output	
		SHORT	N	---	---	5V output	

【DC12V】

12V power	ATX Power	Output	Note
Always ON	Y	12V output	
Stop	N	Stop	

7-6. Default setting

The reference board is shipped by the following initial setting.



JP2, JP3, JP5, JP6, JP8, JP9 pattern

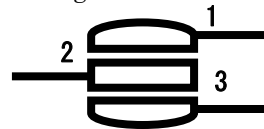

JP4, JP7 pattern

【Jumper】

Part name	Initial setting	Content
JP1	SHORT 2-3	Self-power mode (ATX power)
JP2	SHORT	HDD-5V control it in GPIO[4]
JP3	SHORT	System clock is 50MHz mode
JP4	SHORT 1-2	USB2.0 clock is external crystal
JP5	OPEN	Normal boot
JP6	OPEN	HDD-5V use the U3 output
JP7	SHORT 1-2	System clock is crystal mode
JP8	SHORT	MB86C30 implement ES1
JP9	OPEN	Use VBUS control circuit

【Parts assembly】

Part name	Assembly	Content
TP1~TP5	N	Test pin
C8	N	Capacitor for U3(MIC2505-1YM) output delay control
C61	N	Capacitor for 1.2V power
D7~D12	N	ESD diode for USB2.0/USB3.0
T1, T2	N	Common mode choke for USB3.0 SSRX/SSTX
R9	N	Pull-down resistor for X1
R21	Y	Pull-up resistor for SPI-FLASH WP
R23	N	Pull-down resistor for SPI-FLASH WP
R11	N	Pull-down resistor for X2
U3	Y	5V power switch
U4	N	Oscillator for SYSCLK
X1	Y	Crystal for SYS_XI/XO
X2	Y	Crystal for U2_XI/XO