

MB87077

6-bit, 4-channel Electronic Volume Controller

The Fujitsu MB87077 is a 6-bit, 4-channel electronic volume controller. A digital signal input controls gain every 0.5 dB step from 0dB to -32dB. It has been fabricated in CMOS technology and designed to operate with low power. Its digital inputs and outputs are TTL compatible.

The MB87077 is available in a 24-pin plastic DIP or SOP package.

- Gain variable range: 0 dB to -32 dB by 0.5 dB or -∞
- Gain variable range is expanded to connect two channels serially (0 dB to -64 dB)
- Each channel gain can be set respectively
- Low power consumption: 12 mW at +5 V
- Easy microprocessor interface (6-bit parallel I/O)
- Test function is provided (to confirm internal data)
- Data is initialized by reset signal (all channels are set to 0db)
- Single power supply: +5 V
- Logic I/O is TTL compatible
- Package and ordering information:
 - 24-pin plastic DIP, order as MB87077P
 - 24-pin plastic SOP, order as MB87077PF

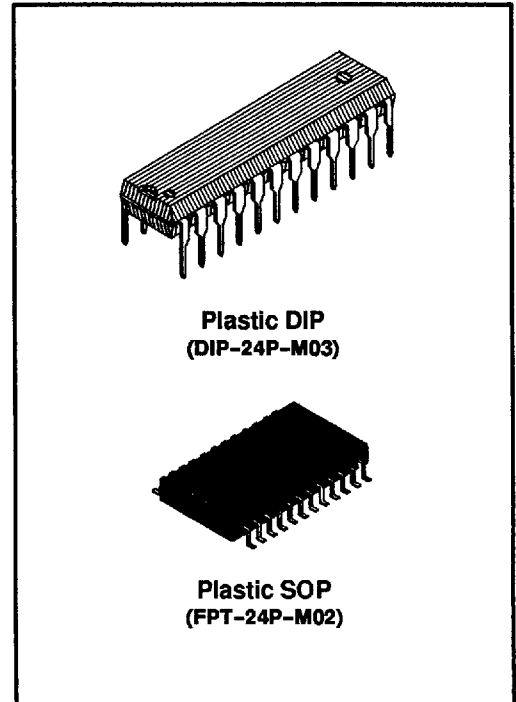

ABSOLUTE MAXIMUM RATINGS

Parameter	Symbol	Pin Name	Value	Unit
Positive Supply Voltage	V_{DD}	V_{DD}	-0.3 to +6	V
Negative Supply Voltage	V_{SS}	V_{SS}	-6 to +0.3	V
Digital Input Voltage	V_{DI}	All digital input pins	-0.3 to $V_{DD} + 0.3$	V
Analog Input Voltage	V_{AI}	A_{10} to A_{13}	$V_{SS} - 0.3$ to $V_{DD} + 0.3$	V
Digital Output Voltage	V_{DO}	All digital output pins	-0.3 to $V_{DD} + 0.3$	V
Analog Output Voltage	V_{AO}	A_{08} to A_{03}	$V_{SS} - 0.3$ to $V_{DD} + 0.3$	V
Digital Output Current	I_{DO}	All digital output pins	-10 to 10	mA
Analog Output Current	I_{AO}	A_{00} to A_{03}	-10 to 10	mA
Storage Temperature	T_{STG}		-40 to +125	°C

— Note —

Permanent device damage may occur if absolute maximum ratings are exceeded. Functional operation should be restricted to the conditions as detailed in the operational sections of this data sheet. Exposure to absolute maximum rating conditions for extended periods may affect device reliability.

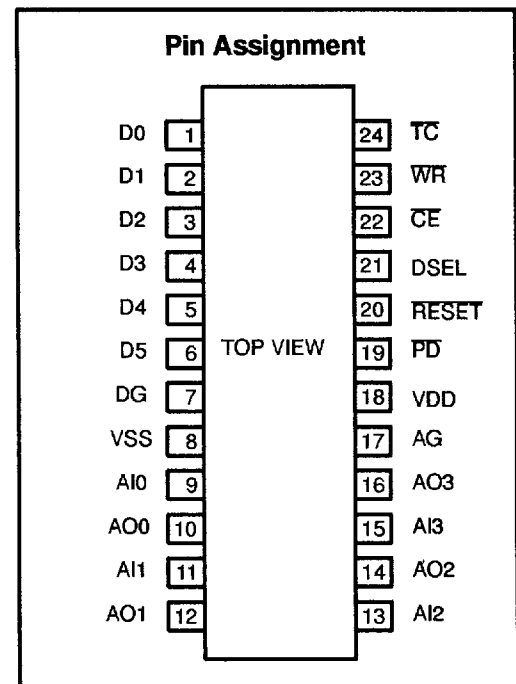

This device contains circuitry to protect the inputs against damage due to high static voltages or electric fields. However, it is advised that normal precautions be taken to avoid application of any voltage higher than maximum rated voltages to this high impedance circuit.

Figure 1. MB87077 Block Diagram

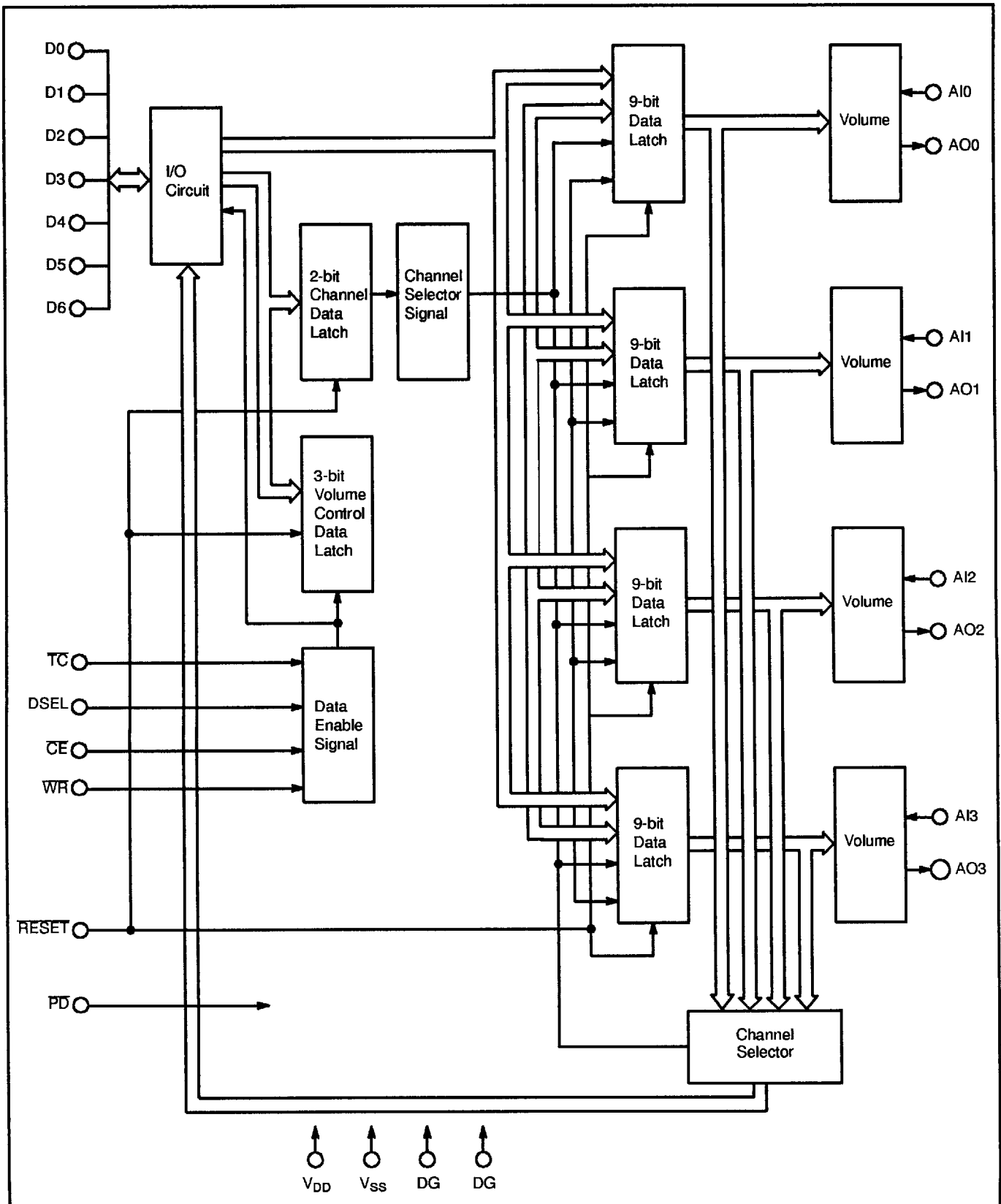

PIN DESCRIPTIONS

	Pin No.	Pin Name	Description
Power Supply	18	V _{DD}	Positive supply voltage, +5V
	8	V _{SS}	Negative supply voltage, -5V
	17	AG	Ground for analog circuitry
	7	DG	Ground for digital circuitry
Digital Input	21	DSEL	Data select input (TTL interface). When this pin is set at high level, DSC1, DSC2, EN, C0 and C32 are in the write enable mode. When this pin is set at low level, GD0 to GD5 are in the write enable mode.
	22	CE	Chip enable input (TTL interface). When this pin is set at low level, data input/output is available. When this pin is at high level, data input/output is inhibited and the pin is set to a high impedance state. This pin is pulled up by a high resistance.
	23	WR	Data write clock input (TTL interface). Data is written at every rising edge of this clock.
	24	TC	Digital signal input/output select input (TTL interface). When this pin is at high level, data can be written through D0 to D5. When this pin is at low level, data can be read output from D0 to D5. This pin is pulled up by a high resistance.
	19	PD	Power down select input (TTL interface). When this pin is at low level, the power down mode is selected. When this pin is at high level, the operation mode is selected. This pin is pulled up by a high resistance.
	20	RESET	Reset input (TTL interface). When this pin is at low level, the data latches for all channels are initialized and the value is set as 0 dB. This pin is pulled up by a high resistance.

Continued on next page

PIN DESCRIPTIONS (continued)



	Pin No.	Pin Name	Description																																																																																																																																																																																																																																																																																																																				
Digital I/O Pins	1	D0	<p>When $\overline{TC} = H$ is at $\overline{CE} = L$, data can be written through D0 to D5. When $\overline{TC} = L$ is at $\overline{CE} = L$, data can be read out from D0 to D5.</p> <p>When DSEL is at high level, DSC1, DSC2, EN, C0 and C32 are in the read/write enable modes. When DSEL is at low level, GD0 to GD5 are in the read/write enable modes.</p> <p>Channel Setting</p> <table border="1"> <thead> <tr> <th>DSC2</th> <th>DSC1</th> <th>Channel</th> </tr> </thead> <tbody> <tr> <td>L</td> <td>L</td> <td>0</td> </tr> <tr> <td>L</td> <td>H</td> <td>1</td> </tr> <tr> <td>H</td> <td>L</td> <td>2</td> </tr> <tr> <td>H</td> <td>H</td> <td>3</td> </tr> </tbody> </table> <p>Digital I/O Setting</p> <table border="1"> <thead> <tr> <th>TC</th> <th>DSEL</th> <th>D0</th> <th>D1</th> <th>D2</th> <th>D3</th> <th>D4</th> <th>D5</th> <th>I/O Modes</th> </tr> </thead> <tbody> <tr> <td rowspan="2">H</td> <td>H</td> <td>DSC</td> <td>DSC</td> <td>EN</td> <td>C0</td> <td>C32</td> <td>X</td> <td rowspan="2">Input mode (setting)</td> </tr> <tr> <td>L</td> <td>GD0</td> <td>GD1</td> <td>GD2</td> <td>GD3</td> <td>GD4</td> <td>GD5</td> </tr> <tr> <td rowspan="2">L</td> <td>H</td> <td>DSC</td> <td>DSC</td> <td>EN</td> <td>C0</td> <td>C32</td> <td>L</td> <td rowspan="2">Output mode (check)</td> </tr> <tr> <td>L</td> <td>GD0</td> <td>GD1</td> <td>GD2</td> <td>GD3</td> <td>GD4</td> <td>GD5</td> </tr> </tbody> </table> <p>Electrical Volume Setting</p> <table border="1"> <thead> <tr> <th colspan="10">Data*</th> <th rowspan="2">Gain (dB)</th> </tr> <tr> <th>GD5</th> <th>GD4</th> <th>GD3</th> <th>GD2</th> <th>GD1</th> <th>GD0</th> <th>EN</th> <th>C0</th> <th>C32</th> <th>D (G)</th> </tr> </thead> <tbody> <tr><td>1</td><td>1</td><td>1</td><td>1</td><td>1</td><td>1</td><td>1</td><td>0</td><td>0</td><td>63</td><td>0</td></tr> <tr><td>1</td><td>1</td><td>1</td><td>1</td><td>1</td><td>0</td><td>1</td><td>0</td><td>0</td><td>62</td><td>-0.5</td></tr> <tr><td>1</td><td>1</td><td>1</td><td>1</td><td>0</td><td>1</td><td>1</td><td>0</td><td>0</td><td>61</td><td>-1</td></tr> <tr><td>1</td><td>1</td><td>1</td><td>1</td><td>0</td><td>0</td><td>1</td><td>0</td><td>0</td><td>60</td><td>-1.5</td></tr> <tr><td>1</td><td>1</td><td>1</td><td>0</td><td>1</td><td>1</td><td>1</td><td>0</td><td>0</td><td>59</td><td>-2</td></tr> <tr><td>1</td><td>1</td><td>1</td><td>0</td><td>1</td><td>0</td><td>1</td><td>0</td><td>0</td><td>58</td><td>-2.5</td></tr> <tr><td>1</td><td>1</td><td>1</td><td>0</td><td>0</td><td>1</td><td>1</td><td>0</td><td>0</td><td>57</td><td>-3</td></tr> <tr><td>1</td><td>1</td><td>1</td><td>0</td><td>0</td><td>0</td><td>1</td><td>0</td><td>0</td><td>56</td><td>-3.5</td></tr> <tr><td>1</td><td>0</td><td>0</td><td>0</td><td>0</td><td>0</td><td>1</td><td>0</td><td>0</td><td>32</td><td>-15.5</td></tr> <tr><td>0</td><td>1</td><td>1</td><td>1</td><td>1</td><td>1</td><td>1</td><td>0</td><td>0</td><td>31</td><td>-16</td></tr> <tr><td>0</td><td>0</td><td>0</td><td>1</td><td>1</td><td>1</td><td>1</td><td>0</td><td>0</td><td>7</td><td>-28</td></tr> <tr><td>0</td><td>0</td><td>0</td><td>1</td><td>1</td><td>0</td><td>1</td><td>0</td><td>0</td><td>6</td><td>-28.5</td></tr> <tr><td>0</td><td>0</td><td>0</td><td>1</td><td>0</td><td>1</td><td>1</td><td>0</td><td>0</td><td>5</td><td>-29</td></tr> <tr><td>0</td><td>0</td><td>0</td><td>1</td><td>0</td><td>0</td><td>1</td><td>0</td><td>0</td><td>4</td><td>-29.5</td></tr> <tr><td>0</td><td>0</td><td>0</td><td>0</td><td>1</td><td>1</td><td>1</td><td>0</td><td>0</td><td>3</td><td>-30</td></tr> <tr><td>0</td><td>0</td><td>0</td><td>0</td><td>1</td><td>0</td><td>1</td><td>0</td><td>0</td><td>2</td><td>-30.5</td></tr> <tr><td>0</td><td>0</td><td>0</td><td>0</td><td>0</td><td>1</td><td>1</td><td>0</td><td>0</td><td>1</td><td>-31</td></tr> <tr><td>0</td><td>0</td><td>0</td><td>0</td><td>0</td><td>0</td><td>1</td><td>0</td><td>0</td><td>0</td><td>-31.5</td></tr> <tr><td>X</td><td>X</td><td>X</td><td>X</td><td>X</td><td>X</td><td>1</td><td>X</td><td>1</td><td>-</td><td>-32</td></tr> <tr><td>X</td><td>X</td><td>X</td><td>X</td><td>X</td><td>X</td><td>1</td><td>1</td><td>0</td><td>-</td><td>0</td></tr> <tr><td>X</td><td>X</td><td>X</td><td>X</td><td>X</td><td>X</td><td>0</td><td>X</td><td>X</td><td>-</td><td>-∞</td></tr> </tbody> </table> <p>* X = don't care. When data is reset, data is set at 0 dB (code 11111100)</p>	DSC2	DSC1	Channel	L	L	0	L	H	1	H	L	2	H	H	3	TC	DSEL	D0	D1	D2	D3	D4	D5	I/O Modes	H	H	DSC	DSC	EN	C0	C32	X	Input mode (setting)	L	GD0	GD1	GD2	GD3	GD4	GD5	L	H	DSC	DSC	EN	C0	C32	L	Output mode (check)	L	GD0	GD1	GD2	GD3	GD4	GD5	Data*										Gain (dB)	GD5	GD4	GD3	GD2	GD1	GD0	EN	C0	C32	D (G)	1	1	1	1	1	1	1	0	0	63	0	1	1	1	1	1	0	1	0	0	62	-0.5	1	1	1	1	0	1	1	0	0	61	-1	1	1	1	1	0	0	1	0	0	60	-1.5	1	1	1	0	1	1	1	0	0	59	-2	1	1	1	0	1	0	1	0	0	58	-2.5	1	1	1	0	0	1	1	0	0	57	-3	1	1	1	0	0	0	1	0	0	56	-3.5	1	0	0	0	0	0	1	0	0	32	-15.5	0	1	1	1	1	1	1	0	0	31	-16	0	0	0	1	1	1	1	0	0	7	-28	0	0	0	1	1	0	1	0	0	6	-28.5	0	0	0	1	0	1	1	0	0	5	-29	0	0	0	1	0	0	1	0	0	4	-29.5	0	0	0	0	1	1	1	0	0	3	-30	0	0	0	0	1	0	1	0	0	2	-30.5	0	0	0	0	0	1	1	0	0	1	-31	0	0	0	0	0	0	1	0	0	0	-31.5	X	X	X	X	X	X	1	X	1	-	-32	X	X	X	X	X	X	1	1	0	-	0	X	X	X	X	X	X	0	X	X	-	-∞
	DSC2	DSC1		Channel																																																																																																																																																																																																																																																																																																																			
	L	L		0																																																																																																																																																																																																																																																																																																																			
	L	H		1																																																																																																																																																																																																																																																																																																																			
	H	L		2																																																																																																																																																																																																																																																																																																																			
	H	H		3																																																																																																																																																																																																																																																																																																																			
TC	DSEL	D0	D1	D2	D3	D4	D5	I/O Modes																																																																																																																																																																																																																																																																																																															
H	H	DSC	DSC	EN	C0	C32	X	Input mode (setting)																																																																																																																																																																																																																																																																																																															
	L	GD0	GD1	GD2	GD3	GD4	GD5																																																																																																																																																																																																																																																																																																																
L	H	DSC	DSC	EN	C0	C32	L	Output mode (check)																																																																																																																																																																																																																																																																																																															
	L	GD0	GD1	GD2	GD3	GD4	GD5																																																																																																																																																																																																																																																																																																																
Data*										Gain (dB)																																																																																																																																																																																																																																																																																																													
GD5	GD4	GD3	GD2	GD1	GD0	EN	C0	C32	D (G)																																																																																																																																																																																																																																																																																																														
1	1	1	1	1	1	1	0	0	63	0																																																																																																																																																																																																																																																																																																													
1	1	1	1	1	0	1	0	0	62	-0.5																																																																																																																																																																																																																																																																																																													
1	1	1	1	0	1	1	0	0	61	-1																																																																																																																																																																																																																																																																																																													
1	1	1	1	0	0	1	0	0	60	-1.5																																																																																																																																																																																																																																																																																																													
1	1	1	0	1	1	1	0	0	59	-2																																																																																																																																																																																																																																																																																																													
1	1	1	0	1	0	1	0	0	58	-2.5																																																																																																																																																																																																																																																																																																													
1	1	1	0	0	1	1	0	0	57	-3																																																																																																																																																																																																																																																																																																													
1	1	1	0	0	0	1	0	0	56	-3.5																																																																																																																																																																																																																																																																																																													
1	0	0	0	0	0	1	0	0	32	-15.5																																																																																																																																																																																																																																																																																																													
0	1	1	1	1	1	1	0	0	31	-16																																																																																																																																																																																																																																																																																																													
0	0	0	1	1	1	1	0	0	7	-28																																																																																																																																																																																																																																																																																																													
0	0	0	1	1	0	1	0	0	6	-28.5																																																																																																																																																																																																																																																																																																													
0	0	0	1	0	1	1	0	0	5	-29																																																																																																																																																																																																																																																																																																													
0	0	0	1	0	0	1	0	0	4	-29.5																																																																																																																																																																																																																																																																																																													
0	0	0	0	1	1	1	0	0	3	-30																																																																																																																																																																																																																																																																																																													
0	0	0	0	1	0	1	0	0	2	-30.5																																																																																																																																																																																																																																																																																																													
0	0	0	0	0	1	1	0	0	1	-31																																																																																																																																																																																																																																																																																																													
0	0	0	0	0	0	1	0	0	0	-31.5																																																																																																																																																																																																																																																																																																													
X	X	X	X	X	X	1	X	1	-	-32																																																																																																																																																																																																																																																																																																													
X	X	X	X	X	X	1	1	0	-	0																																																																																																																																																																																																																																																																																																													
X	X	X	X	X	X	0	X	X	-	-∞																																																																																																																																																																																																																																																																																																													

Continued on next page

PIN DESCRIPTIONS (continued)

	Pin No.	Pin Name	Description
Analog Input	9	AI0	Analog input of channel 0.
	11	AI1	Analog input of channel 1.
	13	AI2	Analog input of channel 2.
	15	AI3	Analog input of channel 3.
Analog Output	10	AO0	Analog output of channel 0. When in a power down mode, this pin is pulled down by a high resistance.
	12	AO1	Analog output of channel 1. When in a power down mode, this pin is pulled down by a high resistance.
	14	AO2	Analog output of channel 2. When in a power down mode, this pin is pulled down by a high resistance.
	16	AO3	Analog output of channel 3. When in a power down mode, this pin is pulled down by a high resistance.

TRUTH TABLE

PD	RESET	CE	TC	DSEL	WR	D0 to D5	Operator Mode
0	X	X	X	X	X		Power down mode
1	0	X	X	X	X		Gain is initialized
1	1	1	X	X	X	Inhibit data input/output (high impedance)	
1	1	0	0	1	X	Data stored in SCH1, SCH2, EN, C0 and C32 are output	Data output mode
1	1	0	0	0	X	Data stored in D0 to D5 are output	Data output mode
1	1	0	1	1		Data stored in SCH1, SCH2, EN, C0 and C32 are input	Data output mode
1	1	0	1	0		Data stored in D0 to D5 are input	Data output mode

Note: X = don't care.

Figure 2. Volume Data Setting Timing Diagram

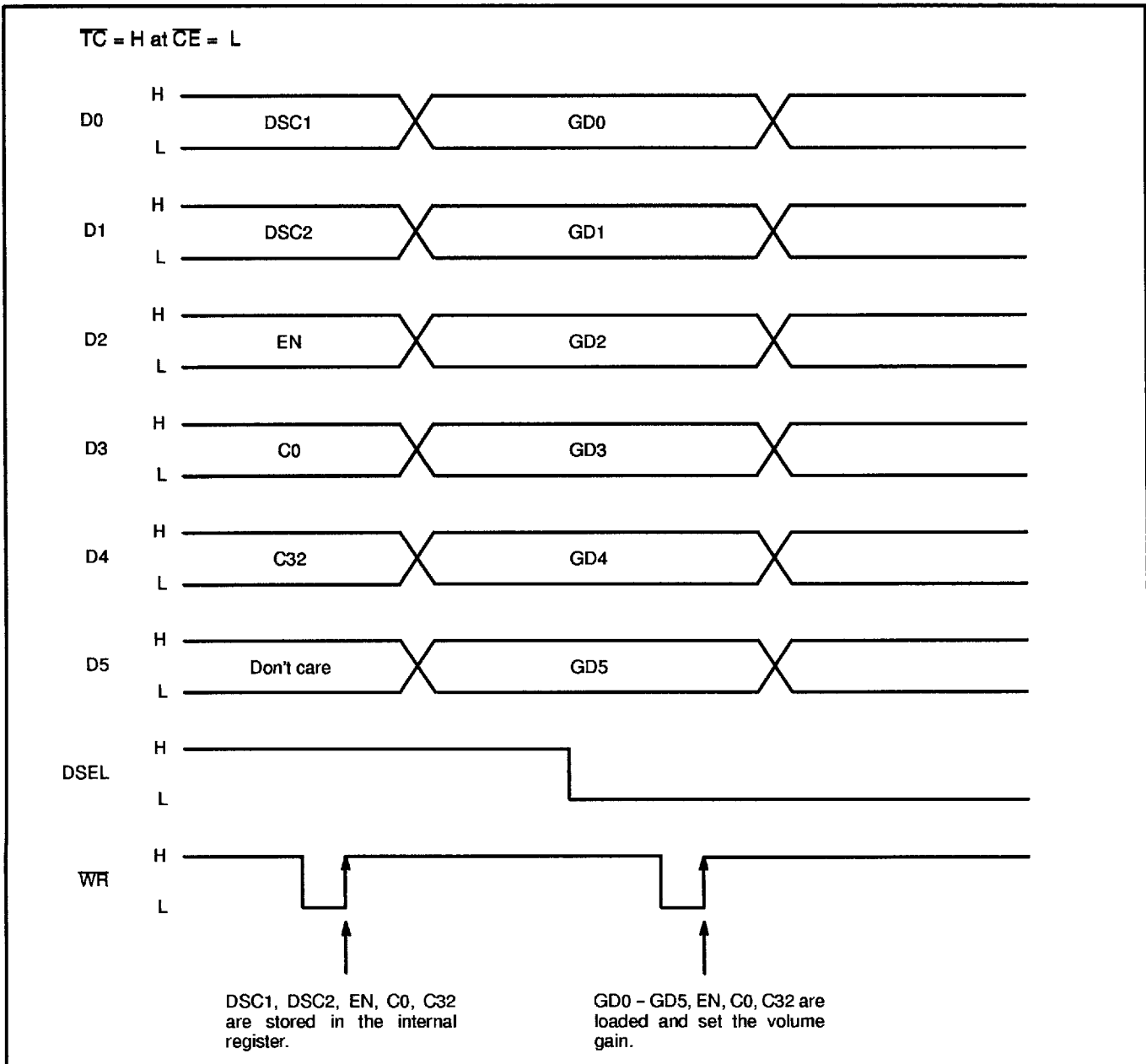

Continued on next page

Figure 2. Volume Data Setting Timing Diagram (continued)

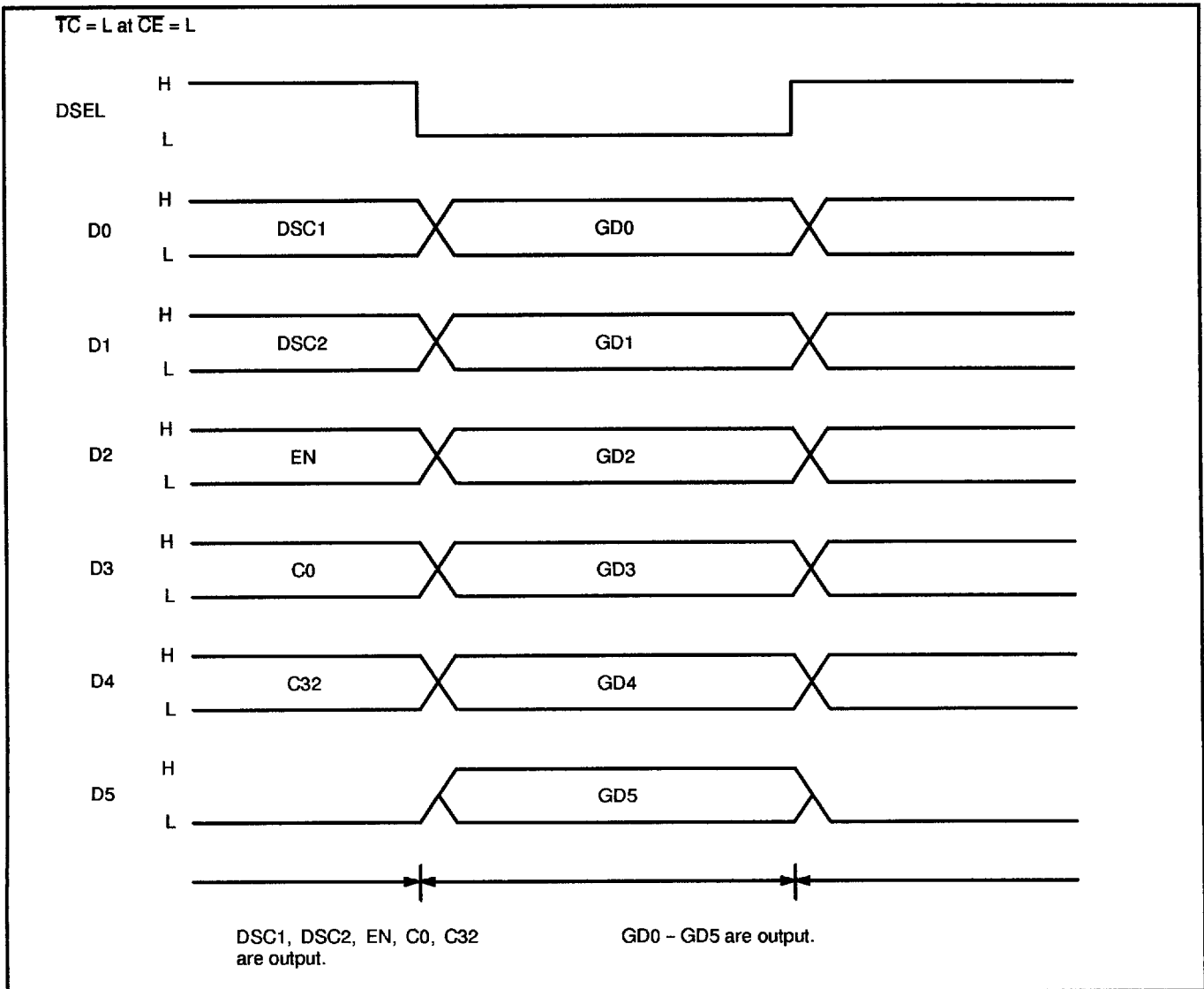

RECOMMENDED OPERATING CONDITIONS

Parameter	Symbol	Pin Name	Value			Unit	
			Min	Typ	Max		
Positive Supply Voltage	V _{DD}	V _{DD}	4.75	5.0	5.25	V	
Negative Supply Voltage	V _{SS}	V _{SS}	-5.25	-5.0	-4.75	V	
Digital Input Voltage	V _{DI}	All digital input pins	0		V _{DD}	V	
Analog Input Voltage	V _{AI}	AIO AI1	$\pm 5\text{ V} \pm 10\%$	-2.5		2.5	V
		AI2 AI3	$\pm 5\text{ V} \pm 5\%$	-3.0		3.0	V
Analog Output Load Resistance	R _{AL}	AO0 - AO3	30			k Ω	
Analog Output Load Capacitance	C _{AL}	AO0 - AO3			50	pF	
Operating Temperature	T _A		-20		70	°C	
Analog Input Frequency	f _{AI}		0		20	kHz	

ELECTRICAL CHARACTERISTICS

(V_{DD} = +5 V +5%, V_{SS} = -5 V +5%, T_A = -20 to +70°C, dBm referenced to 600 Ω)

Parameter	Symbol	Pin Name	Condition	Value			Unit	
				Min	Typ	Max		
Positive Supply Current	I _{DD1}	V _{DD}	No Load	P \bar{D} = H		1.2	2.0	mA
	I _{DD2}			P \bar{D} = L			0.5	mA
Negative Supply Current	I _{SS1}	V _{SS}		P \bar{D} = H	-2.0	-1.2		mA
	I _{SS2}			P \bar{D} = L	-0.5			mA
Digital Input Low Voltage	V _{IL}	All digital input pins		0		0.8	V	
Digital Input High Voltage	V _{IH}			2.2		V _{DD}	V	
Digital Input Low Current	I _{IL}	D0 - D5 WR, DSEL	V _I = GND	-10		10	μ A	
Digital Input High Current	I _{IH}		V _I = V _{DD}	-10		10	μ A	
Digital Output Low Voltage	V _{OL}	All digital output pins	I _{OL} = 2mA	0		0.4	V	
Digital Output High Voltage	V _{OH}		I _{OH} = 2mA	2.6		V _{DD}	V	
Supply Deviation Rejection Ratio	S _{VRD}	V _{DD} , All analog output pins	Supply Voltage Deviation $\Delta V_{SV} = \pm 150\text{ mA}$	60			dB	
	S _{VRS}	V _{SS} , All analog output pins		60			dB	

Continued on next page

ELECTRICAL CHARACTERISTICS (continued)

Parameter	Symbol	Pin Name	Condition	Value			Unit	
				Min	Typ	Max		
Pull up Current	I_{PLU}	RESET, TC PD, CE	$V_I = GND$	-100	-50	-25	μA	
Analog Input Resistance	R_{AIN}	All Analog Output Pins		100	150	300	$k\Omega$	
Analog Output Voltage	V_{AO}		Offset Voltage		-25	0	25	mV
			AC Volt.	$+5V \pm 10\%$	0		5	Vp-p
	$+5V \pm 5\%$			0		6	Vp-p	
Analog Output Maximum Gain	G_{MAX}		Analog Input 5Vp-p	Gain code "111111"	-0.5	0	+0.5	dB
Analog Output Step	ΔG		Below 20 kHz	$63 > D(G) > 0$	0.25	0.5	0.75	dB
Analog Output Gain	G				(Typ)-1	$\frac{D(G)-63}{2}$	(Typ)+1	dB
Harmonic Noise	N_{HH}		Input = 5Vp-p 1 kHz, $G = 0dB$		60	80		dB
Output Noise	N_{IC1}		Input = GND, $G = 0dB$ BW = 0.3 kHz - 20 kHz				-65	dBm
	N_{IC2}		Input = GND, $G = 0dB$ BW = 0.3 kHz - 3.4 kHz				-70	dBm
Cross Talk between Channels	N_{CT}	1 channel AIN = 5Vp-p Remains channels AIN = GND $G = 0dB$ (N = 0 - 3)		70	80		dB	

AC CHARACTERISTICS

(V_{DD} = +5 V +5%, V_{SS} = -5 V +5%, T_A = -20 to +70°C, dBm referenced to 600 Ω)

Parameter	Symbol	Pin Name	Value			Unit
			Min	Typ	Max	
WR High Width	t _{WHWR}	WR	500			ns
WR Low Width	t _{WLWR}	WR	500			ns
DATA Set up Time	t _{SD}	D0 - D5, WR	200			ns
DSEL Set up Time	t _{SDS}	DSEL, WR	200			ns
TC Set up Time	t _{STC}	TC, WR	200			ns
CE Set up Time	t _{SCE}	CE, WR	200			ns
DATA Hold Time	t _{HD}	D0 - D5, WR	200			ns
DSEL Hold Time	t _{HDS}	DSEL, WR	200			ns
TC Hold Time	t _{HTC}	TC, WR	200			ns
CE Hold Time	t _{HCE}	CE, WR	200			ns
Rise Time 1	t _{r1}	WR	0		20	ns
Fall Time 1	t _{f1}	WR	0		20	ns
Rise Time 2	t _{r2}	D0 - D5, CE, TC, DSEL	0		20	ns
Fall Time 2	t _{f2}	D0 - D5, CE, TC, DSEL	0		20	ns
Digital Input Low Width	t _{WLRP}	RESET, PD	1			μs
DATA Output Enable Switching Time 1	t _{DOE1}	TC, D0 - D5			500	ns
DATA Output Enable Switching Time 2	t _{DOE2}	TC, D0 - D5			500	ns
DATA Output Switching Time	t _{DCH}	DSEL D0 - D5			500	ns

Note: Please refer to the timing diagram for test conditions.

Figure 3. Timing Diagram

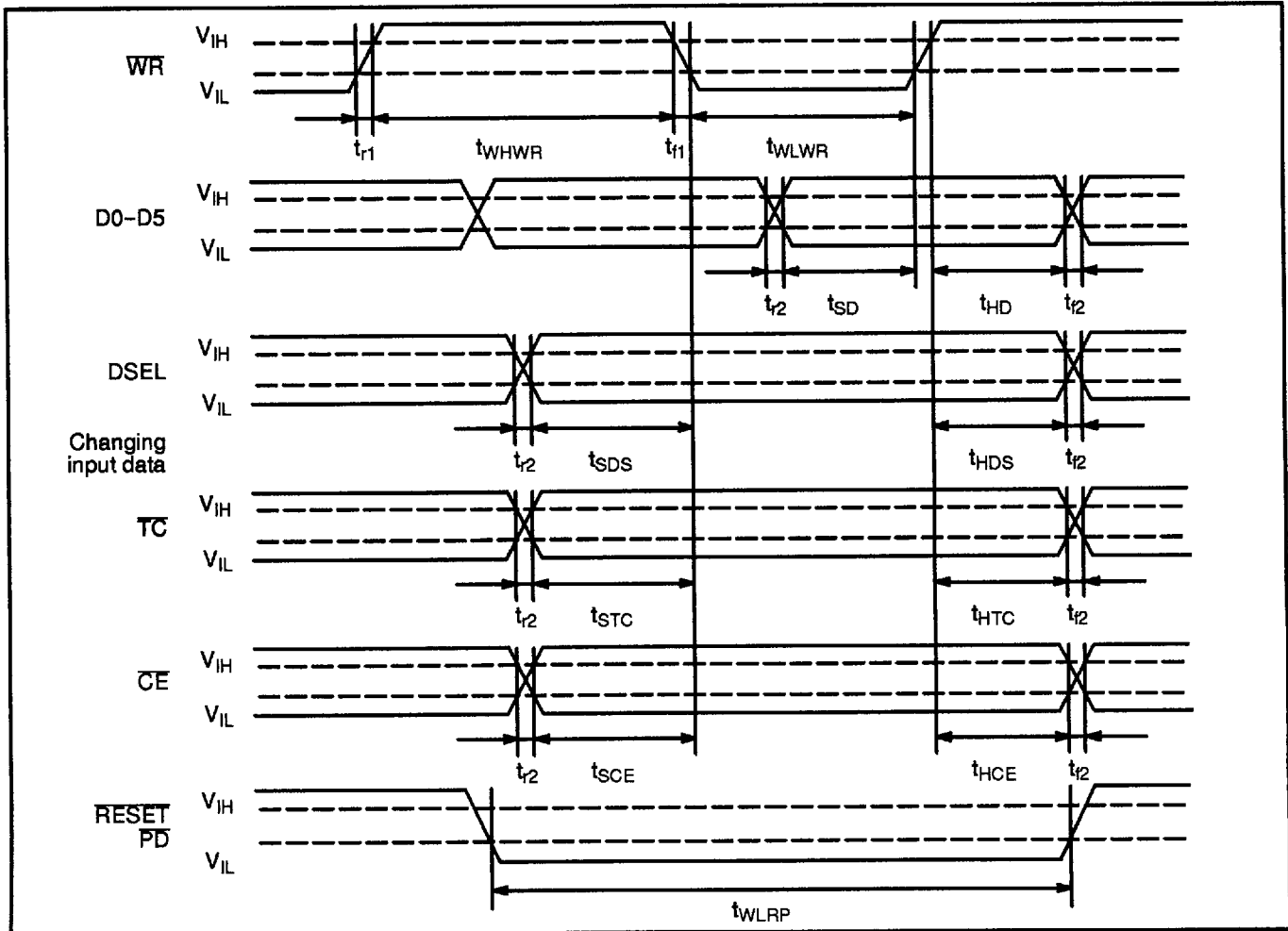
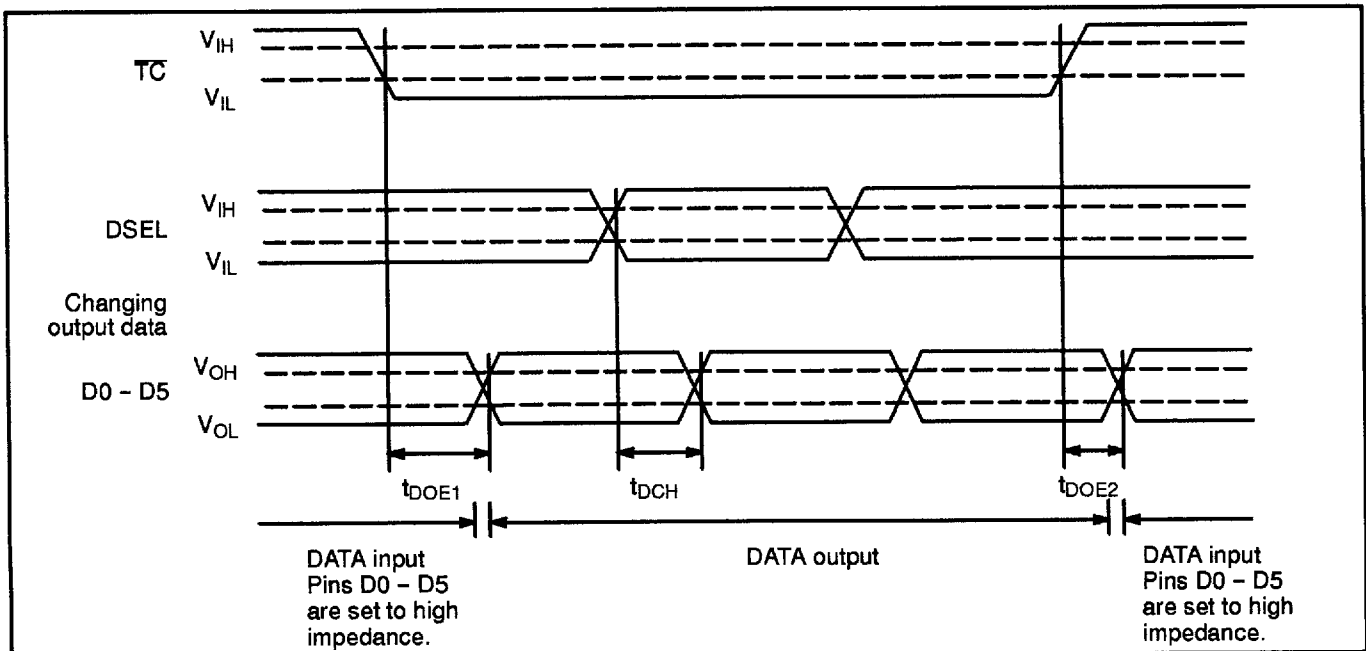
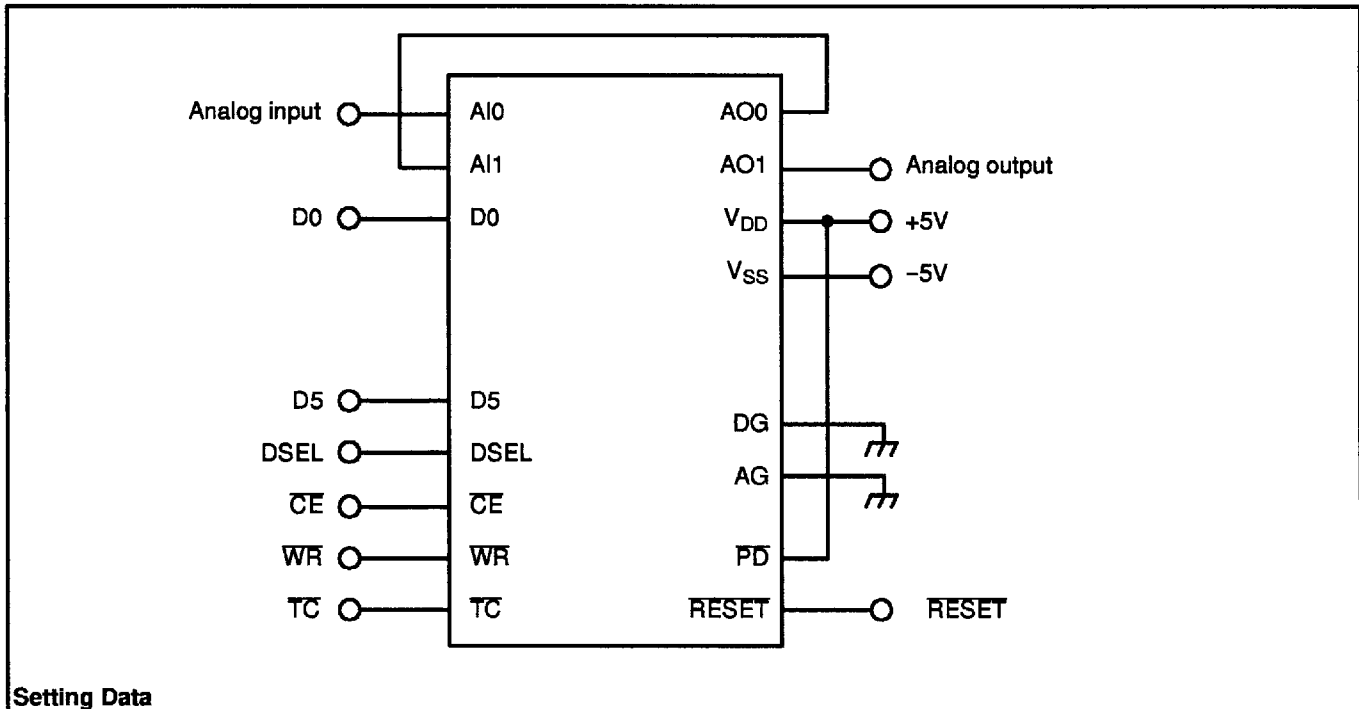

Figure 4. Timing Diagram (CE = L)



Gain variable range is expanded (0 db to -64 dB by 0.5 dB steps) if two channels are connected in series.



Setting Data

Setting Gain (dB)	Data Set (channel 0)									Data Set (channel 1)								
	GD5	GD4	GD3	GD2	GD1	GD0	EN	C0	C32	GD5	GD4	GD3	GD2	GD1	GD0	EN	C0	C32
0	X	X	X	X	X	X	1	1	0	1	1	1	1	1	1	1	0	0
-0.5	X	X	X	X	X	X	1	1	0	1	1	1	1	1	0	1	0	0
-1.0	X	X	X	X	X	X	1	1	0	1	1	1	1	0	1	1	0	0
⋮																		
-31.0	X	X	X	X	X	X	1	1	0	0	0	0	0	0	1	1	0	0
-31.5	X	X	X	X	X	X	1	1	0	0	0	0	0	0	0	1	0	0
-32.0	1	1	1	1	1	1	1	0	0	X	X	X	X	X	X	1	0	1
-32.5	1	1	1	1	1	0	1	0	0	X	X	X	X	X	X	1	0	1
-33.0	1	1	1	1	0	1	1	0	0	X	X	X	X	X	X	1	0	1
⋮																		
-63.0	0	0	0	0	0	1	1	0	0	X	X	X	X	X	X	1	0	1
-63.5	0	0	0	0	0	0	1	0	0	X	X	X	X	X	X	1	0	1
-64.0	X	X	X	X	X	X	1	0	1	X	X	X	X	X	X	1	0	1

Figure 5. Application Example

Note: X = don't care.

PACKAGE DIMENSIONS

