

# **MB89352**

## **SCSI Protocol Controller (SPC)**

### **with On-Chip Drivers/Receivers**

---

Edition 1.0  
September 1989

#### **GENERAL DESCRIPTION**

The MB89352 CMOS LSI SPC (SCSI Protocol Controller) is a circuit designed for easy control of the small computer system interface (SCSI).

The MB89352 can be used as a peripheral LSI circuit for an 8- or 16-bit MPU to realize high-level SCSI control. The SPC can control all the SCSI interface signals and handle almost all the interface control procedures. The on-chip driver/receivers allow for direct connection to the SCSI BUS.

This LSI circuit has an 8-byte FIFO data buffer register and a transfer byte counter that is 24 bits long. Furthermore, the MB89352 can serve as either an INITIATOR or a TARGET device for the SCSI, and can therefore be used for either an I/O controller or a host adapter.

#### **SCSI Compatibility**

- Full support for SCSI control (ANSI X3.1311986 Specification) except for synchronized transfer mode
- Serves as either INITIATOR or TARGET

#### **Data Transfer Rate/Byte Counter**

- 8-byte FIFO data timing control
- 24-bit transfer byte counter

#### **Drive Options (on-chip driver/receiver)**

- Single-ended

#### **Selectable Transfer Modes**

- DMA Transfer
- Program Transfer
- Manual Transfer

#### **Clock Requirements**

- 8 MHz clock

#### **Technology/Power Requirements**

- Silicon-gate CMOS
- Single +5 V power supply

#### **Available Packaging**

- 48-pin DIP or FLAT plastic packages

**ABSOLUTE MAXIMUM RATINGS<sup>1</sup>**

Rating	Designator	Values		Unit
		Min.	Max.	
Supply Voltage	$V_{CC}$	$V_{SS} - 0.3$	7.0	V
Input Voltage	$V_I$	$V_{SS} - 0.3$	7.3	V
Output Voltage <sup>2</sup>	$V_O$	$V_{SS} - 0.3$	7.3	V
Storage Temperature	$T_{STG}$	-55	150	°C

Notes: 1 Permanent device damage may occur if the above absolute maximum ratings are exceeded. Functional operation should be restricted to the conditions as detailed in the operational sections of this data sheet.

Exposure to absolute maximum rating conditions for extended periods may affect device reliability.

2 Should not exceed  $V_{CC} + 0.5V$ .

**RECOMMENDED OPERATING CONDITIONS**

Parameter	Designator	Values			Unit
		Min.	Typ.	Max.	
Supply Voltage	$V_{CC}$	4.75	5.0	5.25	V
Operating Ambient Temperature	$T_A$	0		+ 70	°C

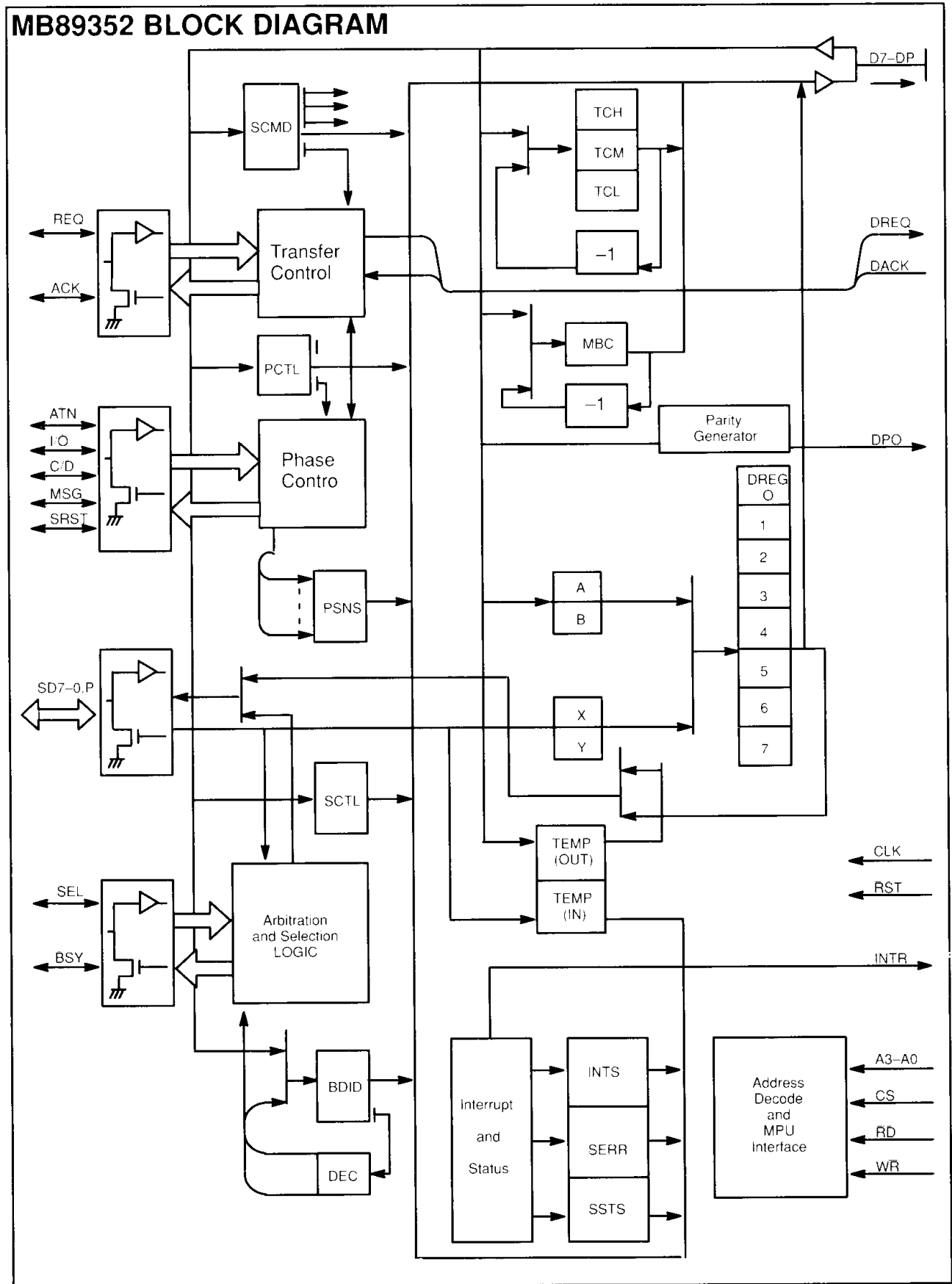

## PIN ASSIGNMENTS

### 48-Pin Plastic DIP

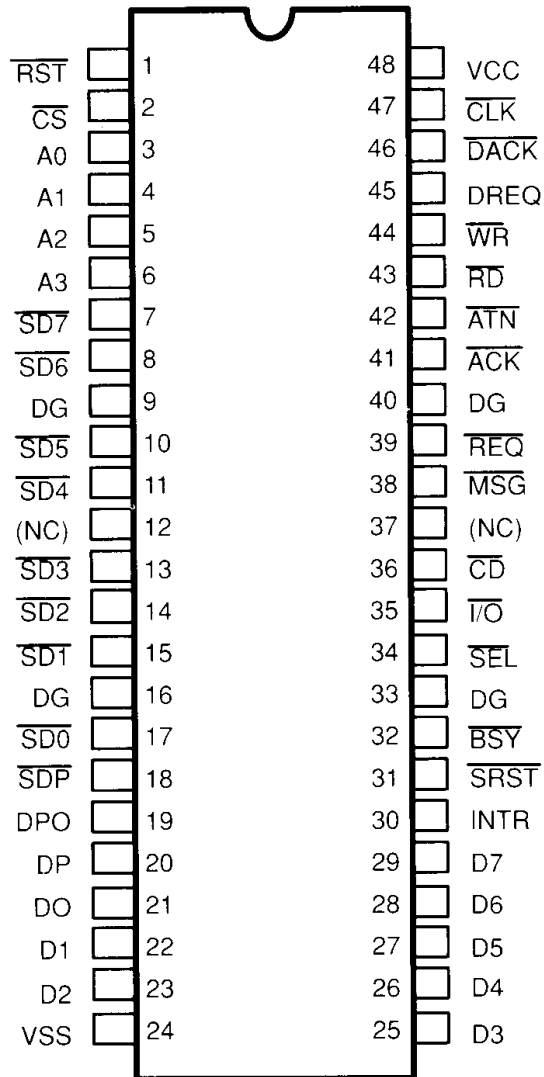

DIP-48P-M02

# PIN ASSIGNMENTS (Continued)

## 48-Pin Plastic Flat Package

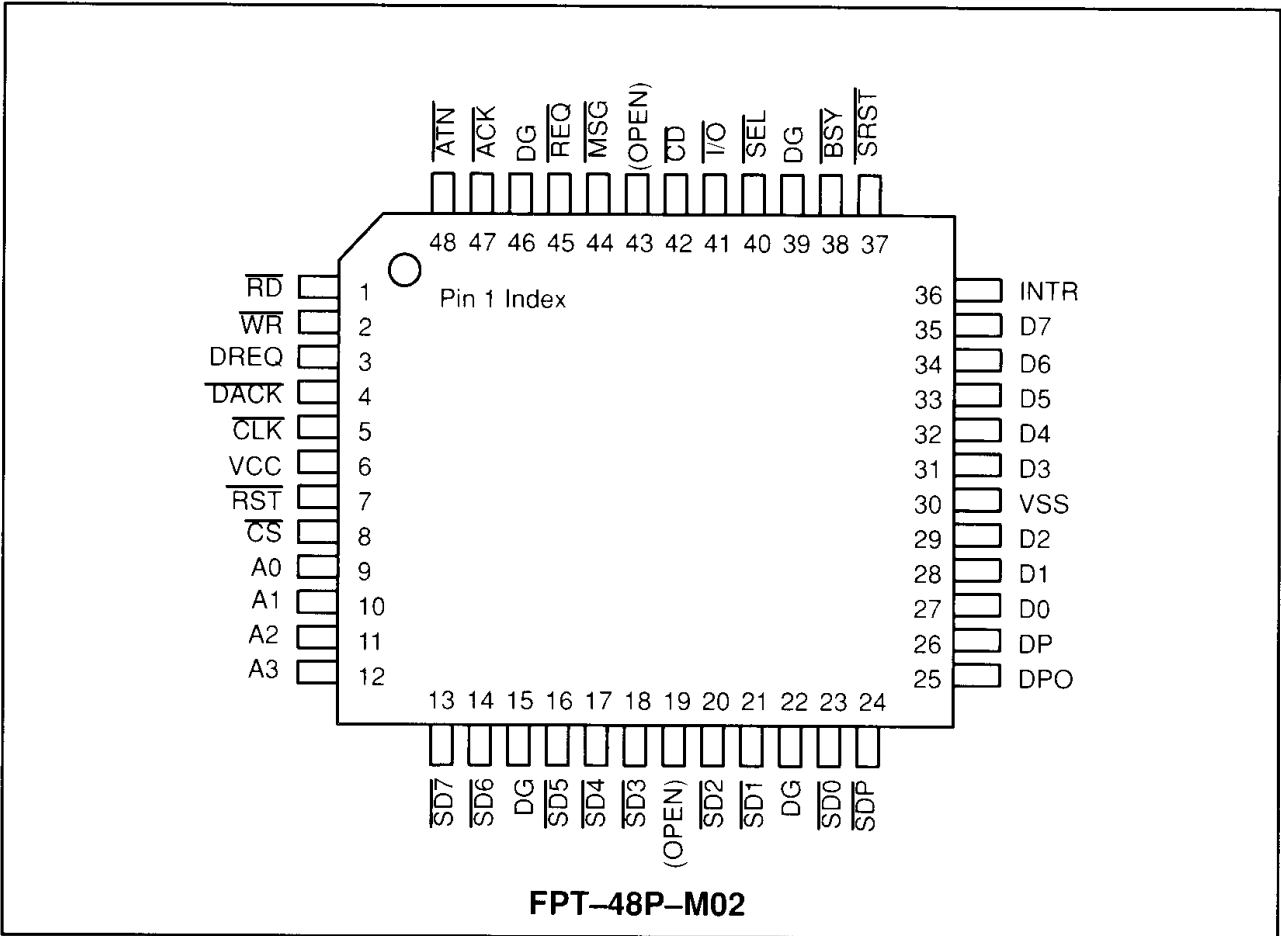

## PIN DESCRIPTIONS

Designator	Pin No.		I/O	Function
	DIP	FPT		
V <sub>CC</sub>	48	6	—	+5V power supply.
V <sub>SS</sub>	24	30	—	Circuit ground.
DG	9 16 33 40	15 22 39 46	—	Ground (OV) for internal drivers. The SCSI bus drivers can sink up to 48-mA each. Up to 16 drivers can be active at once. We recommend a good solid ground plane.
$\overline{\text{CLK}}$	47	5	I	Clock input for controlling internal operation and data transfer speed of the SPC.
RST	1	7	I	Asynchronous reset signal used to clear all internal circuits of the SPC.
$\overline{\text{CS}}$	2	8	I	Input selection enable signal for accessing an internal register. When active low, the following input/output signals are valid: RD, WR, A3-A0, DP7-DP0 and DP.
A0 A1 A2 A3	3 4 5 6	9 10 11 12	I	Address input signals for selecting an internal register in SPC. MSB is A3; LSB is A0.  When $\overline{\text{CS}}$ is active, read/write is enabled for an internal register selected by these address inputs via data bus lines D0-D7 and DP.
$\overline{\text{RD}}$	43	1	I	This strobe input is used for reading out the contents of the SPC internal register, and is effective only when $\overline{\text{CS}}$ input is active. While $\overline{\text{RD}}$ is active, the contents of an internal register selected by A0 to A3 inputs are placed on data bus lines D7 to D0, DP. For a data transfer cycle in the program transfer mode, the rising edge of $\overline{\text{RD}}$ is used as a timing signal indicating the end of data read.
WR	44	2	I	The strobe input is used for writing data into an SPC internal register, and is effective only when $\overline{\text{CS}}$ input is active. On the rising edge of this signal, data placed on data bus lines D0 to D7, DP are loaded into an internal register selected by A0 to A3 inputs. For a data transfer cycle in the program transfer mode, the rising edge of this signal is used as a timing signal indicating data ready status.
DP D0 D1 D2 D3 D4 D5 D6 D7	20 21 22 23 25 26 27 28 29	26 27 28 29 31 32 33 34 35	I/O	Used to write/read data to/from an internal register in the SPC. The data bus is 3-state and bidirectional. The MSB is D7 and the LSB is D0; DP is an odd parity bit.  When both $\overline{\text{CS}}$ and RD inputs are active, the contents of a selected internal register are output to the data bus. In operations other than read/write, the data bus is kept at a high-Z level.

Continued on following page

## PIN DESCRIPTIONS

Designator	Pin No.		I/O	Function
	DIP	FPT		
DPO	19	25	O	Outputs an odd parity of D0–D7. If parity bit is not generated for external memory, DPO can be used as an input parity bit for DP.
INTR	30	36	O	The INTR output signal is issued by the SPC and requests an interrupt to indicate completion of an internal operation or the occurrence of an error. Except for an interrupt caused by the RSTI input (reset condition in SCSI).  When an interrupt request is granted, the INTR signal remains active until the interrupt is cleared.
DREQ	45	3	O	For a data transfer cycle in DMA mode, this signal is used to indicate a request for data transfer between the SPC and the external buffer memory. In an output operation, this signal becomes active to request a data transfer from the external buffer memory when the SPC internal data buffer register has free space available. In an input operation, it becomes active to request data transfer to the external buffer memory when the SPC internal data buffer register contains valid data.
$\overline{\text{DACK}}$	46	4	I	An active low response signal to the DREQ which request data transfer in between SPC and the external memory in the DMA mode. This signal in DMA mode functions similarly to the signal combination of $\overline{\text{CS}}=\text{low}$ , $\text{A3}=\text{high}$ , $\text{A2}=\text{low}$ , $\text{A1}=\text{high}$ , and $\text{A0}=\text{low}$ (selection of DREG) in the program transfer mode. Since the DREG is selected by this $\overline{\text{DACK}}$ signal in the DMA mode instead of the address input from A3–A0, data transfer in between DREG of SPC and external memory is possible.
SD0 SD1 SD2 SD3 SD4 SD5 SD6 SD7 SDP	17 15 14 13 11 10 8 7 18	23 21 20 18 17 16 14 13 24	I/O	Active low bi-directional SCSI data bus.  MSB : $\overline{\text{SD7}}$ , LSB : $\overline{\text{SD0}}$ Odd parity bit : $\overline{\text{SDP}}$  Parity check for the SCSI data bus is programmable.
$\overline{\text{SEL}}$	34	40	I/O	A signal to issue or detect selection or reselection phase. In selection phase, an initiator asserts this signal, and in reselection phase the signal is asserted by the target.
$\overline{\text{BSY}}$	32	38	I/O	This signal indicates the SCSI bus use condition. This signal goes "L" when SPC is in arbitration phase or working as a target. Also, this signal is used to detect bus free phase with $\overline{\text{SEL}}$ signal.

Continued on following page

## PIN DESCRIPTIONS

Designator	Pin No.		I/O	Function																																				
	DIP	FPT																																						
I/O C/D MSG	35 36 38	41 42 44	I/O	<p>Signals to indicate actual phase of information transfer phase as follows:</p> <table border="1"> <thead> <tr> <th>MSG</th> <th>C/D</th> <th>I/O</th> <th>Phase Name</th> </tr> </thead> <tbody> <tr> <td>0</td> <td>0</td> <td>0</td> <td>Data Out Phase</td> </tr> <tr> <td>0</td> <td>0</td> <td>1</td> <td>Data In Phase</td> </tr> <tr> <td>0</td> <td>1</td> <td>0</td> <td>Command Phase</td> </tr> <tr> <td>0</td> <td>1</td> <td>1</td> <td>Status Phase</td> </tr> <tr> <td>1</td> <td>0</td> <td>0</td> <td>Reserved</td> </tr> <tr> <td>1</td> <td>0</td> <td>1</td> <td>Reserved</td> </tr> <tr> <td>1</td> <td>1</td> <td>0</td> <td>Message Out Phase</td> </tr> <tr> <td>1</td> <td>1</td> <td>1</td> <td>Message In Phase</td> </tr> </tbody> </table> <p>These signals are output from the target and initiator receives them always.</p>	MSG	C/D	I/O	Phase Name	0	0	0	Data Out Phase	0	0	1	Data In Phase	0	1	0	Command Phase	0	1	1	Status Phase	1	0	0	Reserved	1	0	1	Reserved	1	1	0	Message Out Phase	1	1	1	Message In Phase
MSG	C/D	I/O	Phase Name																																					
0	0	0	Data Out Phase																																					
0	0	1	Data In Phase																																					
0	1	0	Command Phase																																					
0	1	1	Status Phase																																					
1	0	0	Reserved																																					
1	0	1	Reserved																																					
1	1	0	Message Out Phase																																					
1	1	1	Message In Phase																																					
REQ	39	45	I/O	In the data transfer phase, the REQ signal is used to notify the INITIATOR that the TARGET is ready to receive or send data. The REQ input is used as a timing control signal in the data transfer sequence.																																				
ACK	41	47	I/O	In the data transfer phase, the acknowledge signal is in response to a transfer request (REQ) signal from the TARGET. In the same way as REQ, an ACK input is used as a timing signal in the data transfer sequence.																																				
ATN	42	48	I/O	A signal to indicate attention condition. This signal is only output from an initiator.																																				
SRST	31	37	I/O	SCSI reset signal to be enabled by register setting. SCSI input from other SCSI devices is non-maskable.																																				
NC	12, 37		—	Not connected																																				
OPEN	—	19, 43		Reserved. (Do not make external connections to these pins)																																				



## ADDRESSING OF INTERNAL REGISTERS

SPC has internal registers, consisting of 15 bytes, that are accessible from an external circuit. These internal registers are used for controlling SPC internal operation and indicating SPC processing status/result status. A unique address is assigned to each internal register, and a particular register is identified by address bits A3 to A0. The following table shows internal register addressing:

**Table 1. Internal Register Addressing**

Register	Mnemonic	Operation	Chip Select (CS)	Address Bits			
				A3	A2	A1	A0
Bus Device ID	BDID	R	0	0	0	0	0
		W					
SPC Control	SCTL	R	0	0	0	0	1
		W					
Command	SCMD	R	0	0	0	1	0
		W					
Open	—	—	0	0	0	1	1
Interrupt Sense	INTS	R	0	0	1	0	0
Reset Interrupt		W					
Phase Sense	PSNS	R	0	0	1	0	1
SPC Diagnostic Control	SDGC	W					
SPC Status	SSTS	R	0	0	1	1	0
—		W					
SPC Error Status	SERR	R	0	0	1	1	1
—		W					
Phase Control	PCTL	R	0	1	0	0	0
		W					
Modified Byte Counter	MBC	R	0	1	0	0	1
—		W					

*Continued on following page*

**Table 1. Internal Register Addressing**

Register	Mnemonic	Operation	Chip Select ( $\overline{CS}$ )	Address Bits			
				A3	A2	A1	A0
Data Register	DREG	R	0	1	0	1	0
		W					
Temporary Register	TEMP	R	0	1	0	1	1
		W					
Transfer Counter High	TCH	R	0	1	1	0	0
		W					
Transfer Counter Middle	TCM	R	0	1	1	0	1
		W					
Transfer Counter Low	TCL	R	0	1	1	1	0
		W					

## BIT ASSIGNMENTS

The following table shows the bit assignments to each internal register. When accessing an internal register (in read/write), remember the following:

1. The internal register block includes the read-only/write-only register and those having different meanings in read and write operations.
2. A write command to a read-only register is ignored.
3. If the write-only register is read out, the data and parity bit are undefined.
4. At bit positions indicating "\_" for a write in either 1 or 0 may be written.

**Table 2. Bit Assignments for Internal Registers**

HEX Address	Register and Mnemonic	R/W Operation	7 (MSb)	6	5	4	3	2	1	0 (LSb)	Parity	
0	Bus Device ID (BDID)	R	#7	#6	#5	#4	#3	#2	#1	#0	0	
		W	---						ID4	ID2	ID1	—
1	SPC Control (SCTL)	R/W	Reset & Disable	Control Reset	Diag Mode	ARBIT Enable	Parity Enable	Select Enable	Reselect Enable	INT Enable	P	
2	Command (SCMD)	R	Command Code			RST Out	Intercept Xfer	Transfer PRG Xfer	Modifier 0	Modifier Term Mode	P	
		W										
3		R										
		W										
4	Interrupt Sense (SERR)	R	Selected	Reselect	Disconnect	Command Complete	Service Required	Time Out	SPC Hard Error	Reset Condition	P	
		W	Reset Interrupt									—
5	Phase Sense (PSNS)	R	REQ	ACK	ATN	SEL	BSY	MSG	C/D	I/O	P	
	SPC Diag. Control (SDGC)	W	Diag. REQ	Diag. ACK	Xfer Enable		Diag. BSY	Diag. MSG	Diag. C/D	Diag. I/O	—	
6	SPC Status (SSTS)	R	Connected		SPC BSY	XFER In Progress	SCSI RST	TC=0	DREG Status		P	
		W	INIT	TARG	—							Full   Empty

*Continued on following page*

### Bit Assignments For Internal Registers

HEX Address	Register and Mnemonic	R/W Operation	7 (MSb)	6	5	4	3	2	1	0 (LSb)	Parity	
8	Phase Control (PCTL)	R	Bus Free Interrupt Enable	0				Transfer Phase			P	
		W						MSG Out	C/D Out	I/O Out		
9	Modified Byte Counter (MBC)	R	0			MBC				P		
		W	—			—				P		
A	Data Register (DREG)	R	Internal Data Register (8 Byte FIFO)									P
		W	Bit 7	Bit 6	Bit 5	Bit 4	Bit 3	Bit 2	Bit 1	Bit 0		
B	Temporary Register (TEMP)	R	Temporary Data (Input: From SCSI)									P
		W	Temporary Data (Output: To SCSI)									
C	Transfer Counter High (TCH)	R	Transfer Counter High (MSB)									P
		W	Bit 23	Bit 22	Bit 21	Bit 20	Bit 19	Bit 18	Bit 17	Bit 16		
D	Transfer Counter Mid (TCM)	R	Transfer Counter Middle (2nd Byte)									P
		W	Bit 15	Bit 14	Bit 13	Bit 12	Bit 11	Bit 10	Bit 9	Bit 8		
E	Transfer Counter LOW (TCL)	R	Transfer Counter Low (LSB)									P
		W	Bit 7	Bit 6	Bit 5	Bit 4	Bit 3	Bit 2	Bit 1	Bit 0		

These bit assignments for the MB89352 internal registers are identical to those in the MB87030, MB87031, and MB89351. Therefore, SPC replacement from one to another is very easy and does not require any new software design.

**DC CHARACTERISTICS** ( $T_A=0-70^{\circ}\text{C}$ ,  $V_{CC}=5\text{V} \pm 5\%$ )  
 (Recommended operating conditions unless otherwise specified)

**SCSI Bus Signal Pins**

Parameter	Designator	Conditions	Values			Unit
			Min.	Typ.	Max.	
Input High Voltage	$V_{IH}$		2.0	—	5.25	V
Input Low Voltage	$V_{IL}$		0	—	0.8	V
Input High Current	$I_{IH}$	$V_{IH} + 5.25\text{V}$	—	100	400	$\mu\text{A}$
Input Low Current	$I_{IL}$	$V_{IL} + 0\text{V}$	—	-100	-400	$\mu\text{A}$
Output Low Voltage	$V_{OL}$	$V_{CC} = 4.75\text{V}$ $I_{OL} + 48\text{mA}$	—	—	0.5	V
Input Hysteresis Width	$V_{HM}$	—	0.2	0.4	—	V

**DC CHARACTERISTICS** (Continued)**MPU Bus Signal Pins**

Parameter	Designator	Conditions	Values			Unit
			Min.	Typ.	Max.	
Input High Voltage	$V_{IH}$		2.2	—	$V_{CC} + 0.3$	V
Input Low Voltage	$V_{IL}$		$V_{SS} - 0.3$	—	0.8	V
Output High Voltage	$V_{OH}$	$I_{OH} + 0.4$ mA	4.0		$V_{CC}$	V
Output Low Voltage	$V_{OL}$	$I_{OL} + 3.2$ mA	$V_{SS}$		0.4	V
Input Leakage Current	$I_{LIH}$	$V_{IH} + 5.25$			20	$\mu$ A
	$I_{LIL}$	$V_{IL} + 0.0$			-10	$\mu$ A
Input/Output Leakage Current	$I_{LZH}$	$V_{IH} + 5.25$			40	$\mu$ A
	$I_{LZL}$	$V_{IL} + 0.0$			-40	$\mu$ A
Power Supply Current	$I_{CC}$	Input Clock = 8 MHz All Output Pins Open			10	mA

### AC CHARACTERISTICS (Continued)

(Recommended operating conditions unless otherwise noted)

#### Clock Signal

CLK Input					
Parameter	Designator	Values			Unit
		Min.	Typ.	Max.	
CLK Cycle Time	$t_{CLF}$	125		200	ns
CLK High Time	$t_{CHCL}$	44			ns
CLK Pulse Width	$t_{CLCH}$	44			ns
CLK Rising Skew Time	$t_r$			10	ns
CLK Falling Skew Time	$t_f$			10	ns

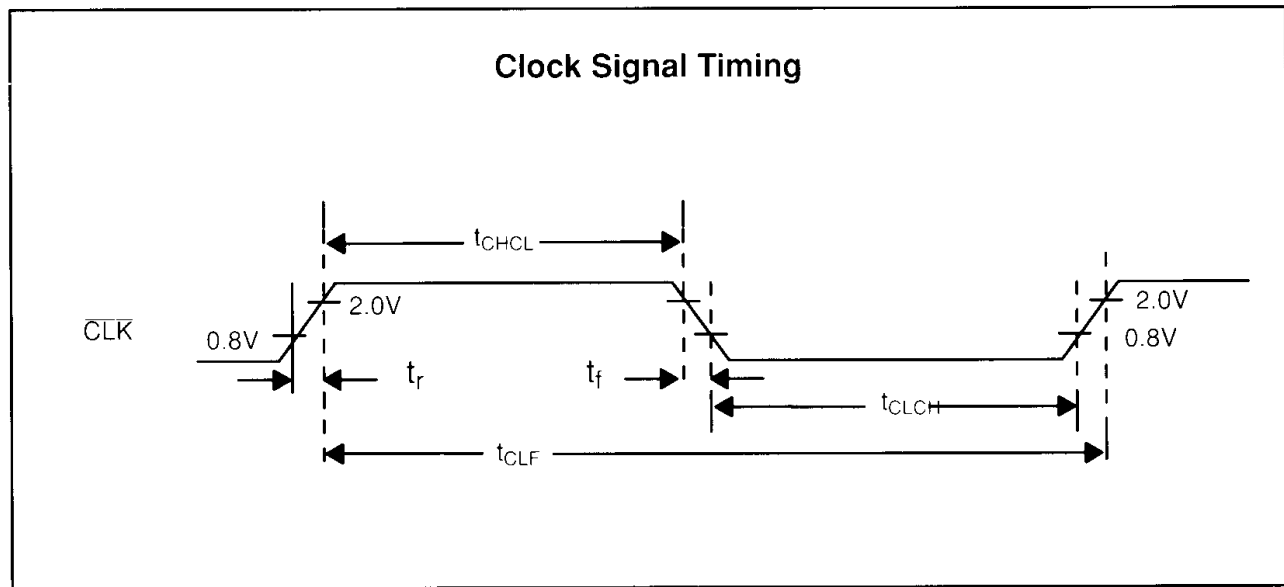

### AC CHARACTERISTICS (Continued)

RST Input					
Parameter	Designator	Values			Unit
		Min.	Typ.	Max.	
RST Pulse Width	$t_{RSTW}$	100			ns

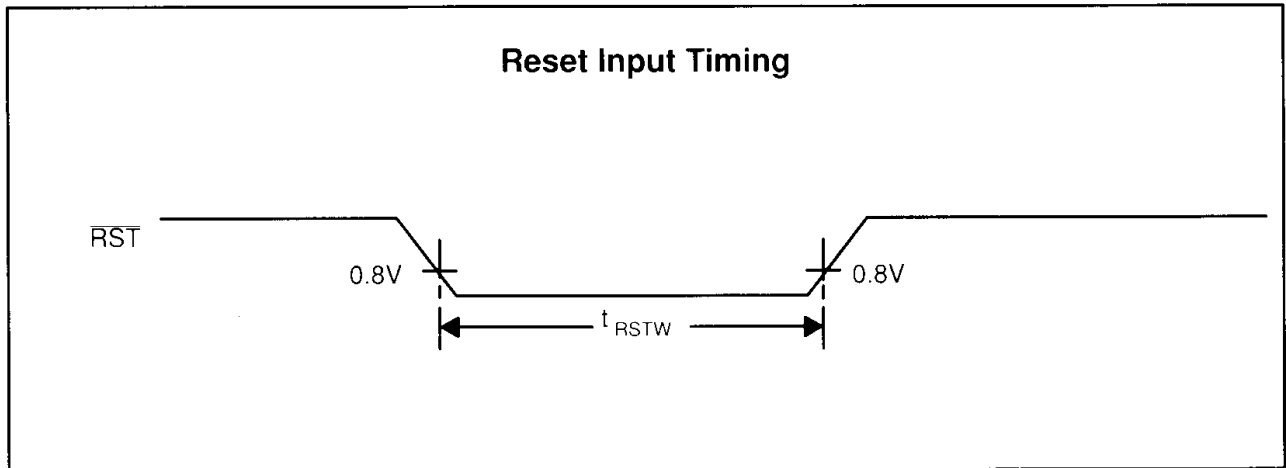



### AC CHARACTERISTICS (Continued)

Register Read					
Parameter	Designator	Values			Unit
		Min.	Typ.	Max.	
Address Setup Time	$t_{ARS}$	40			ns
Address Hold Time	$t_{ARH}$	10			ns
$\overline{CS}$ Setup Time	$t_{CRS}$	25			ns
$\overline{CS}$ Hold Time	$t_{CRH}$	10			ns
Data Valid Time (from $\overline{RD}$ Low) ( $C_L = 80pF$ )	$t_{RLD}$			90	ns
Data Valid Time (from $\overline{RD}$ High) ( $C_L = 20pF$ )	$t_{RHD}$	10		60	ns
$\overline{RD}$ Pulse Width	$t_{RD}$	120			ns

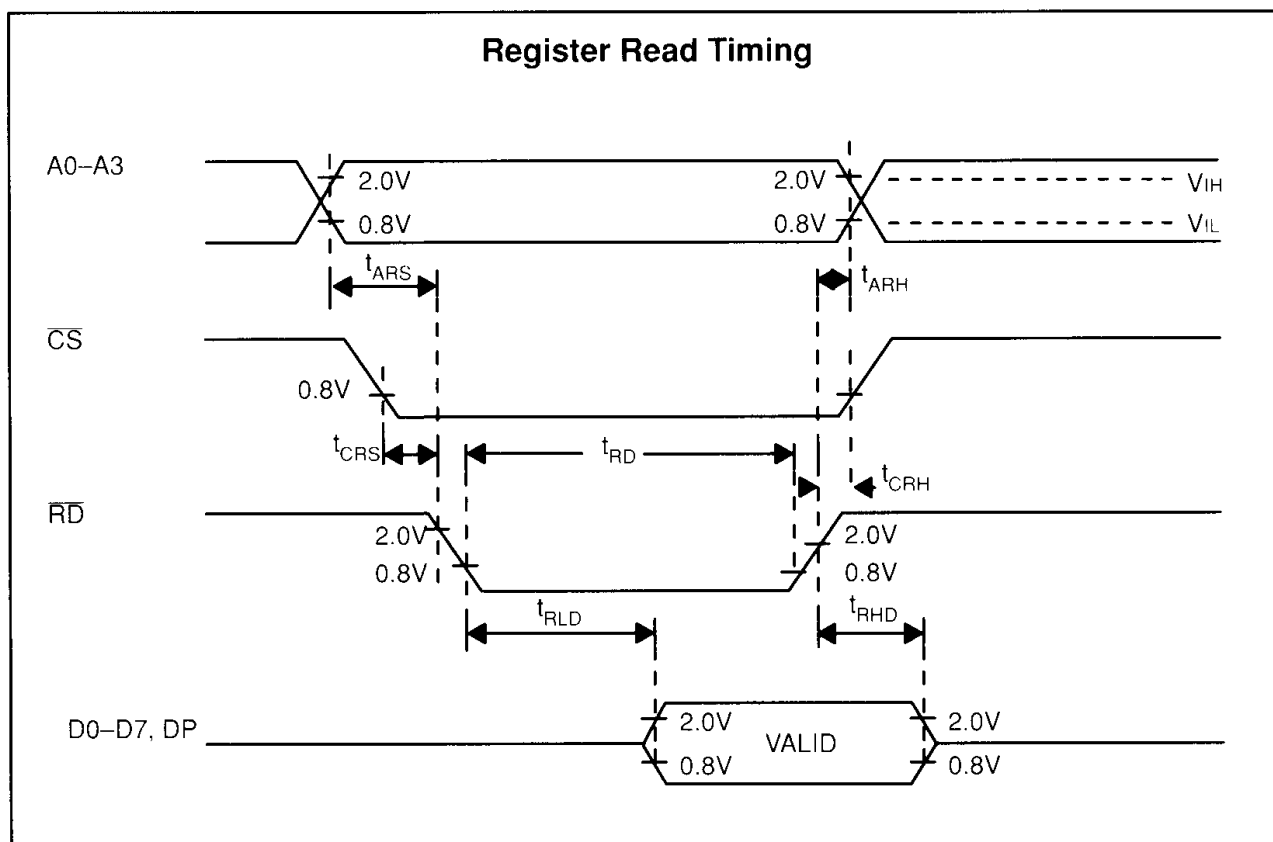

### AC CHARACTERISTICS (Continued)

Register Write					
Parameter	Designator	Values			Unit
		Min.	Typ.	Max.	
Address Setup Time	$t_{AWS}$	40			ns
Address Hold Line	$t_{AWH}$	10			ns
CS Setup Time	$t_{CWS}$	25			ns
CS Hold Time	$t_{CWH}$	10			ns
Data Bus Setup Time	$t_{DWS}$	30			ns
Data Bus Hold Time	$t_{DWH}$	20			ns
WR Pulse Width	$t_{WR}$	100			ns

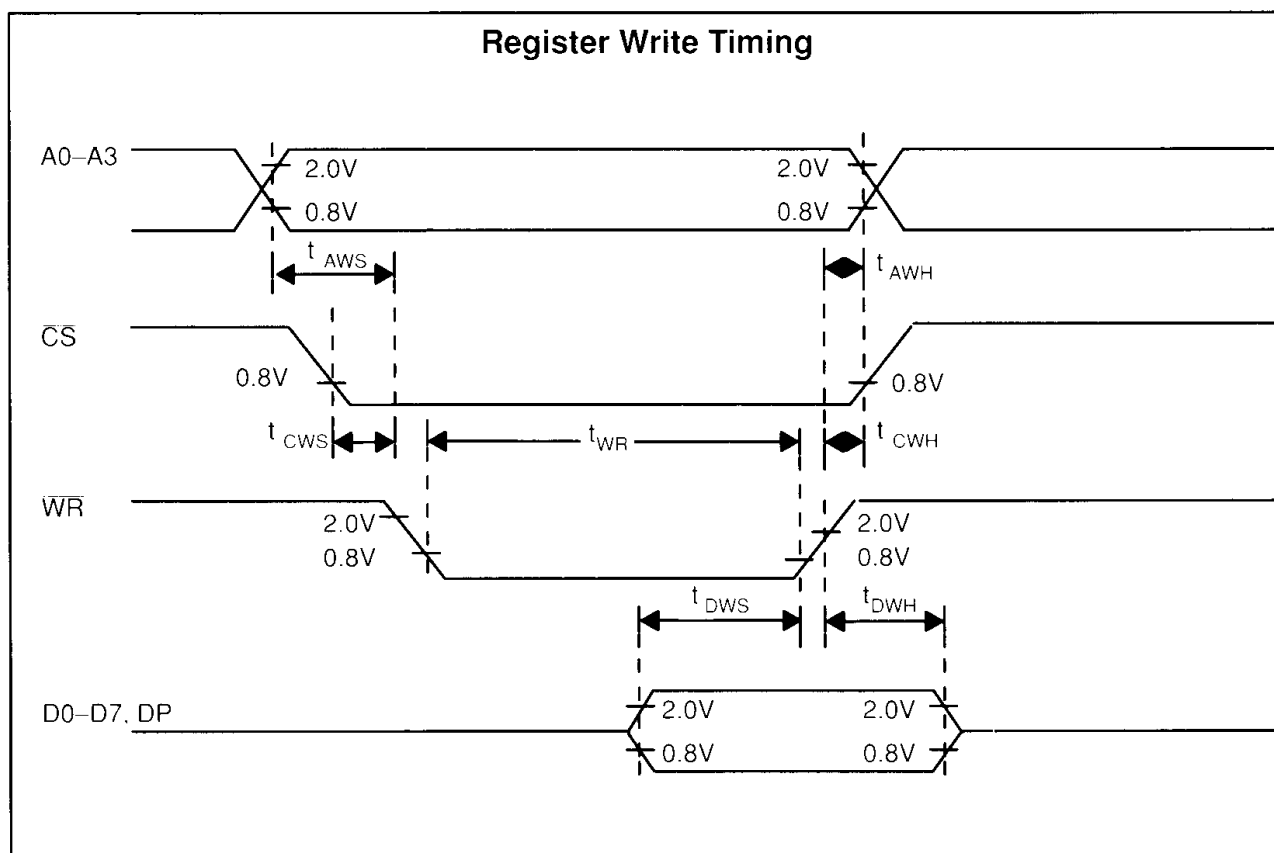

### AC CHARACTERISTICS (Continued)

DPO (Data Parity Output)						
Parameter	Designator	Test Conditions	Values			Unit
			Min.	Typ.	Max.	
Data Bus (D0 – D7) Valid to DPO Valid	$t_{DPVD}$	CL = 30pF			60	ns

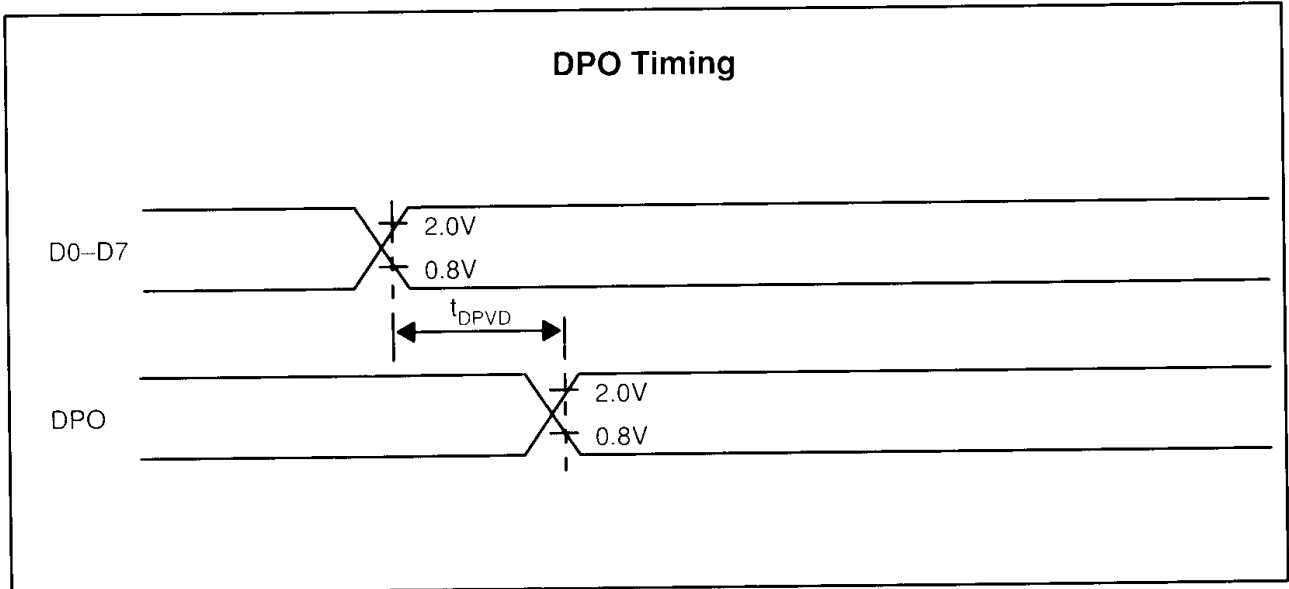

### AC CHARACTERISTICS (Continued)

INTR (Interrupt Request) Output						
Parameter	Designator	Test Conditions	Values			Unit
			Min.	Typ.	Max.	
WR High to INTR Low (Interrupt reset)	$t_{WHIR}$	CL = 10pf	$t_{CLF}$		$2t_{CLF} + 100$	ns
INTR High to WR High	$t_{IRWL}$		0			ns
INTR Reset Cycle Time <sup>1</sup>	$t_{WRCY}$		$4t_{CLF}$			ns

**Note:** <sup>1</sup>Applicable only when interrupt reset is executed.

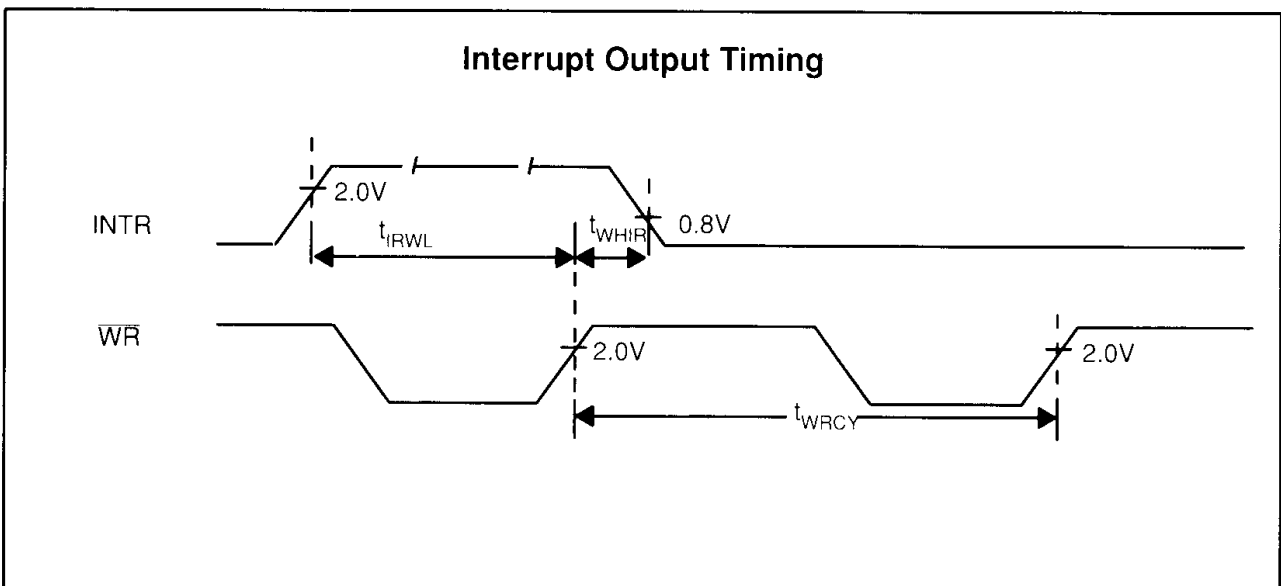

### AC CHARACTERISTICS (Continued)

DMA Access						
Parameter	Designator	Test Conditions	Values			Unit
			Min.	Typ.	Max.	
DREQ High to $\overline{\text{DACK}}$ Low	$t_{\text{DHAL}}$		0			ns
$\overline{\text{WR}}$ and $\overline{\text{RD}}$ Service Time (From $\overline{\text{DACK}}$ Low to $\overline{\text{WR}}$ or $\overline{\text{RD}}$ Low)	$t_{\text{ARWL}}$		40			ns
DREQ Release Time (From $\overline{\text{WR}}$ or $\overline{\text{RD}}$ Low to DREQ Low) <sup>1</sup>	$t_{\text{RWDL}}$	CL = 30 pF	35		150	ns
DACK Hold Time (From $\overline{\text{WR}}$ or $\overline{\text{RD}}$ High to $\overline{\text{DACK}}$ Low)	$t_{\text{RWAH}}$		10			ns
DREG Interval (From DREQ Low to DREQ High)	$t_{\text{DLDH}}$		0			ns
DREG Access Cycle Time (1)	$t_{\text{RWCY}}$		$2t_{\text{CLF}}$			ns
DREG Access Cycle Time (2)	$t_{\text{DMCY}}$		$3t_{\text{CLF}}$			ns

**Note:** 1 The  $\overline{\text{WR}}$  parameter is applicable when the data buffer register is full; the  $\overline{\text{RD}}$  parameter is applicable when the data buffer register is empty.

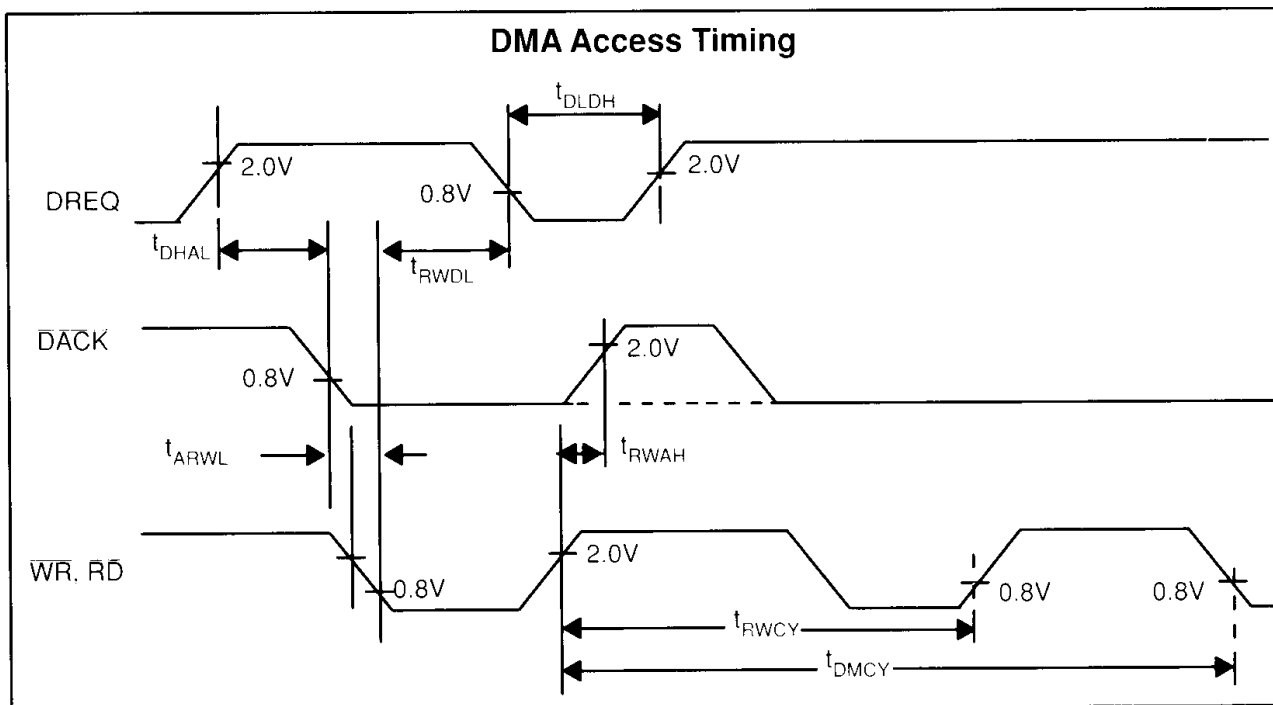

### AC CHARACTERISTICS (Continued)

DREG Access – Program Transfer with INTR (Input Operation)						
Parameter	Designator	Test Conditions	Values			Unit
			Min.	Typ.	Max.	
$\overline{RD}$ Service Time (From INTR High to $\overline{RD}$ Low)	$t_{IHRL}$		0			ns
INTR Release Time (From $\overline{RD}$ High to INTR Low) (Note)	$t_{RHIL}$	CL = 20 pF	35		150	ns
INTR Recovery Time (From INTR Low to INTR High)	$t_{ILIH}$		0			ns
$\overline{RD}$ Recovery Time (From $\overline{RD}$ High to $\overline{RD}$ Low)	$t_{RHRL}$		50			ns

**Note:** This parameter is applicable when the data buffer register is full in the output operation and empty in the input operation.

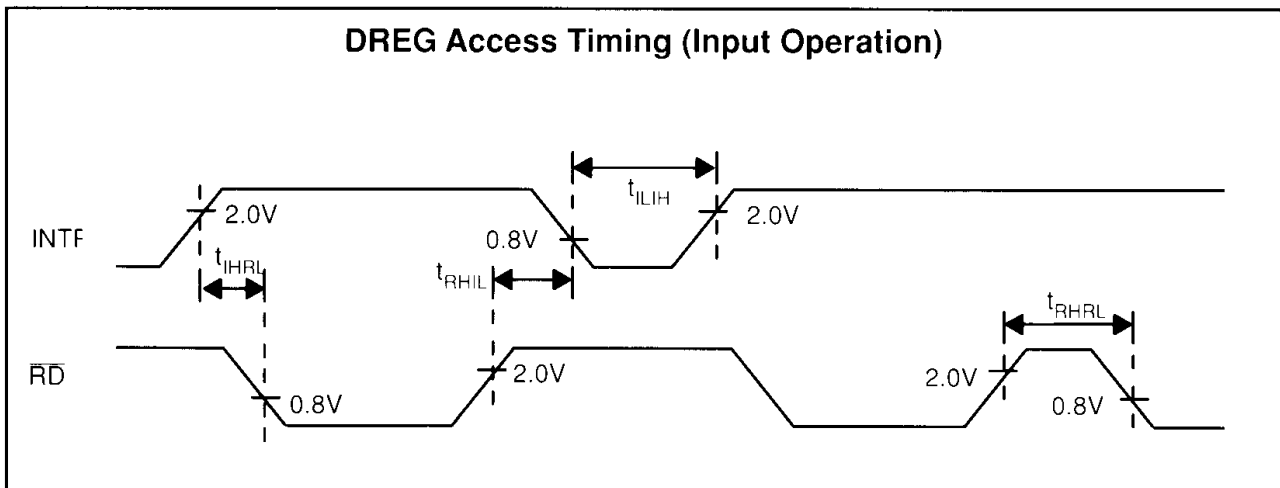

### AC CHARACTERISTICS (Continued)

DREG Access – Program Transfer with INTR (Output Operation)						
Parameter	Designator	Test Conditions	Values			Unit
			Min.	Typ.	Max.	
WR Service Time (From INTR High to WR Low)	$t_{IHWL}$		0			ns
INTR Release Time (From WR High to INTR Low) (Note)	$t_{WLIL}$	CL = 20 pF	35		150	ns
INTR Recovery Time (From WR Low to INTR High)	$t_{ILIH}$		0			ns
WR Cycle Time	$t_{WRCY}$		$2t_{CLF}$			ns

**Note:** This parameter is applicable when the data buffer register is full in the output operation and empty in the input operation.

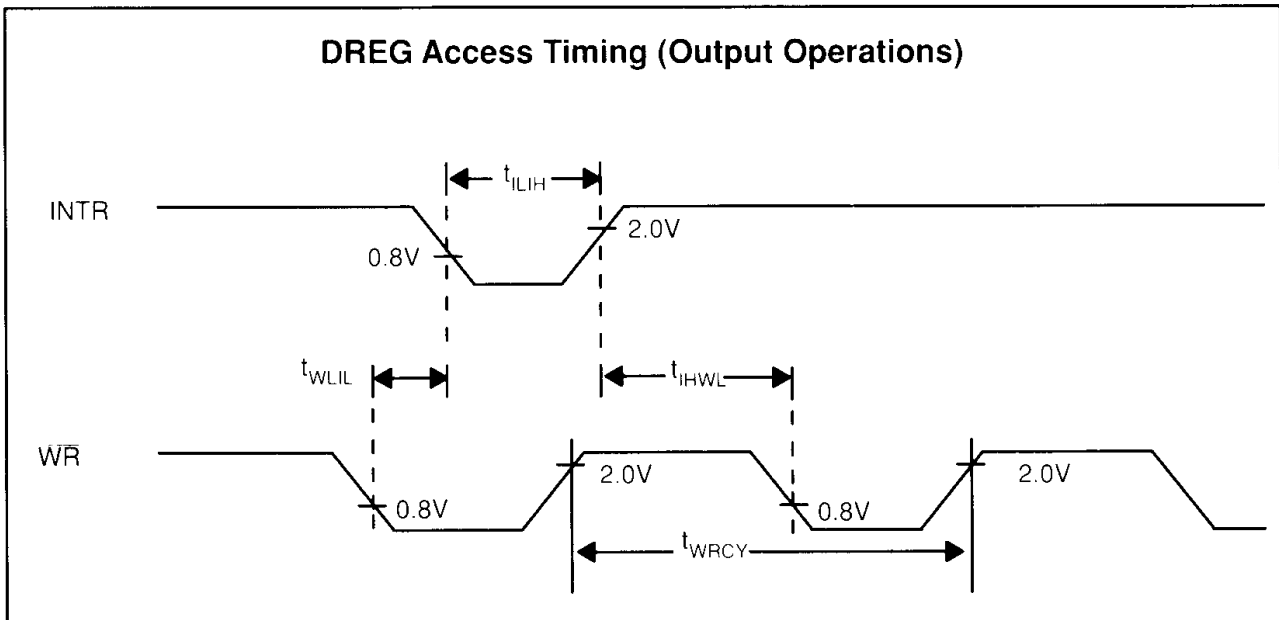

## AC CHARACTERISTICS (Continued)

### SCSI Bus Interface Selection Phase Timing

INITIATOR — Selection With Arbitration					
Parameter	Designator	Values			Unit
		Min.	Typ.	Max.	
Bus Free Time*	t <sub>BFR</sub>	4t <sub>C<sub>LF</sub></sub> +50			ns
Start of Arbitration	t <sub>BFBL</sub>	(6+n)** x t <sub>C<sub>LF</sub></sub>		(7+n) x t <sub>C<sub>LF</sub></sub> +60	ns
$\overline{\text{BSY}}$ Low to Self ID# Output	t <sub>BLID</sub>	0		60	ns
$\overline{\text{BSY}}$ Low to Prioritize	t <sub>ARB</sub>	32t <sub>C<sub>LF</sub></sub> -60			ns
Data Bus Valid to Prioritize	t <sub>AIDV</sub>	200			ns
Bus Usage Permission Granted to $\overline{\text{SEL}}$ Low	t <sub>AWSL</sub>	0		80	ns
$\overline{\text{SEL}}$ Low to Data Bus ID Output, ATN Low	t <sub>SIDA</sub>	11t <sub>C<sub>LF</sub></sub> -30			ns
Select ID# Output to $\overline{\text{BSY}}$ High	t <sub>IDBH</sub>	2t <sub>C<sub>LF</sub></sub> -80			ns
$\overline{\text{BSY}}$ Low to $\overline{\text{SEL}}$ High	t <sub>BLSH</sub>	2t <sub>C<sub>LF</sub></sub>			ns
$\overline{\text{BSY}}$ Low to Select ID# Hold	t <sub>BIDH</sub>	2t <sub>C<sub>LF</sub></sub>			ns
$\overline{\text{SEL}}$ High to INTR High	t <sub>SHIR</sub>			60	ns
$\overline{\text{SEL}}$ Low to $\overline{\text{BSY}}$ High, ID Bit High	t <sub>SBCR</sub>			3t <sub>C<sub>LF</sub></sub> +180	ns
Prioritize to $\overline{\text{BSY}}$ High, ID Bit High	t <sub>PBCR</sub>			110	ns

Notes: \*Bus Free Time : The minimum time period until the booked select command is executed.  
 \*\*TCL register value.

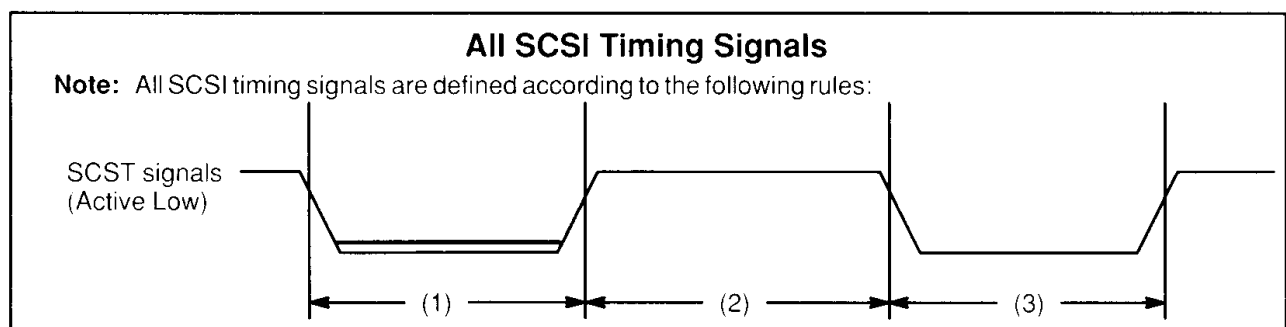

Notes: (1) The SPC outputs low level signal to the bus.  
 (2) All devices hooked up to the bus do not output low level signals.  
 (3) Other devices hooked up to the bus output low level signals.



# AC CHARACTERISTICS (Continued)

## SCSI Bus Interface Selection Phase Timing

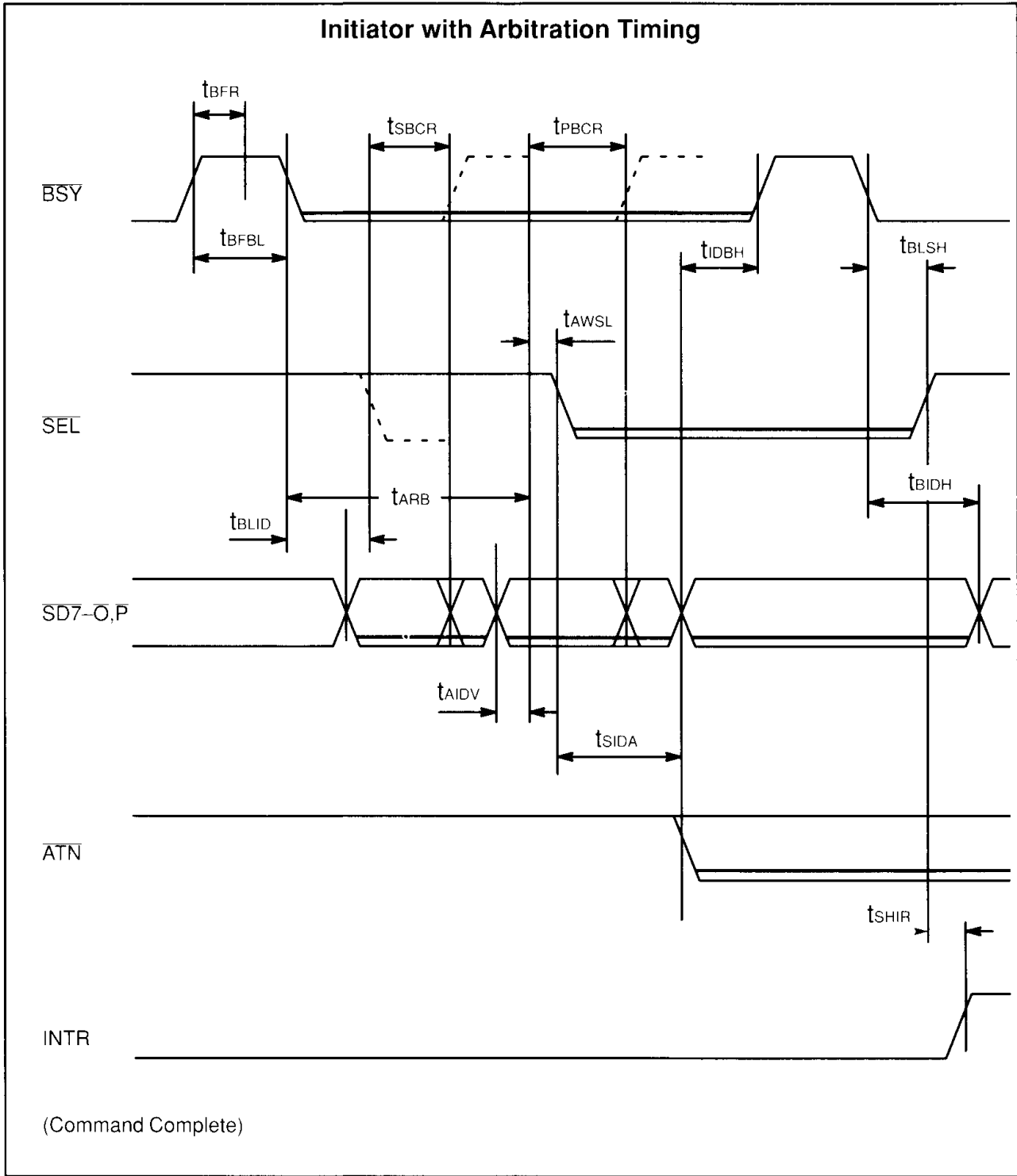

### AC CHARACTERISTICS (Continued)

INITIATOR — Selection Without Arbitration					
Parameter	Designator	Values			Unit
		Min.	Typ.	Max.	
BSY High to Select ID# Output	$t_{FRID}$	$(6+n) \times t_{CLF}$		$(7+n) \times t_{CLF} + 140$	ns
ID# Output to SEL Low	$t_{IDSL}$	$11t_{CLF} - 80$			ns
SEL Low to $\overline{ATN}$ Low	$t_{SLAT}$	$11t_{CLF} - 80$			ns
BSY Low to SEL High	$t_{BLSH}$	$2t_{CLF}$			ns
BSY Low to ID# Hold	$t_{BIDH}$	$2t_{CLF}$			ns
SEL High to INTR High	$t_{SHIR}$			60	ns

**Note:** n=TCL register set value.

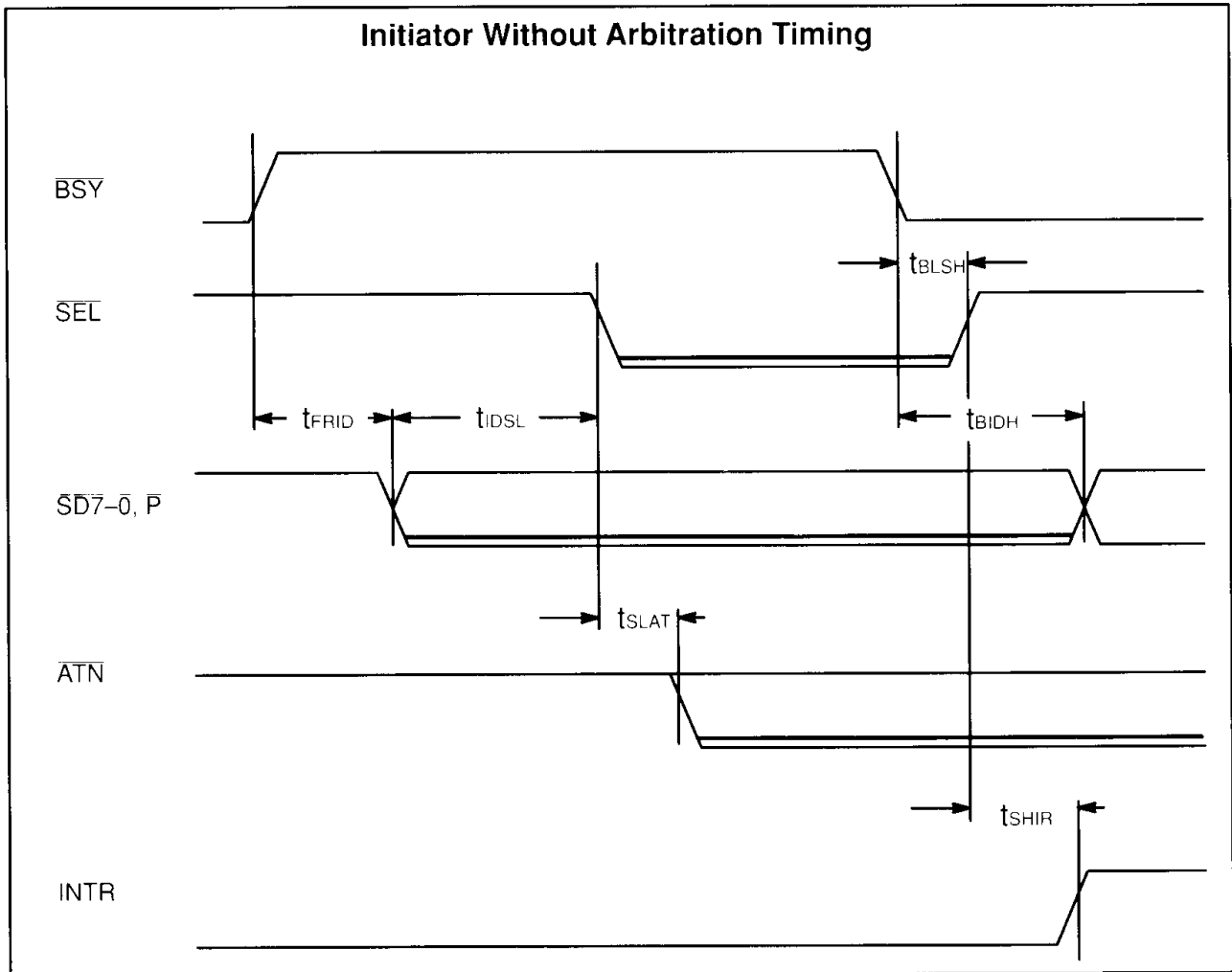

**AC CHARACTERISTICS** (Continued)

<b>TARGET — Selection With Arbitration</b>					
Parameter	Designator	Values			Unit
		Min.	Typ.	Max.	
SEL Low to BSY High	$t_{SLBH}$	0			ns
Data Bus Valid (ID#) to BSY High	$t_{IDBH}$	0			ns
$\overline{I/O}$ High to $\overline{BSY}$ High	$t_{IOHB}$	0			ns
$\overline{BSY}$ High to $\overline{BSY}$ Low	$t_{BHBL}$	$4t_{CLF}$		$5t_{CLF}+140$	ns
BSY Low to ID# Hold	$t_{BLID}$	60			ns
BSY Low to SEL High	$t_{BLSH}$	0			ns
SEL High to Phase Signal Output	$t_{SHPH}$	$3t_{CLF}$		$4t_{CLF}+160$	ns
$\overline{I/O}$ Low to Data Bus Output	$t_{IODE}$	$7t_{CLF}$			ns
SEL High to INTR High	$t_{SHIR}$			$3t_{CLF}+130$	ns

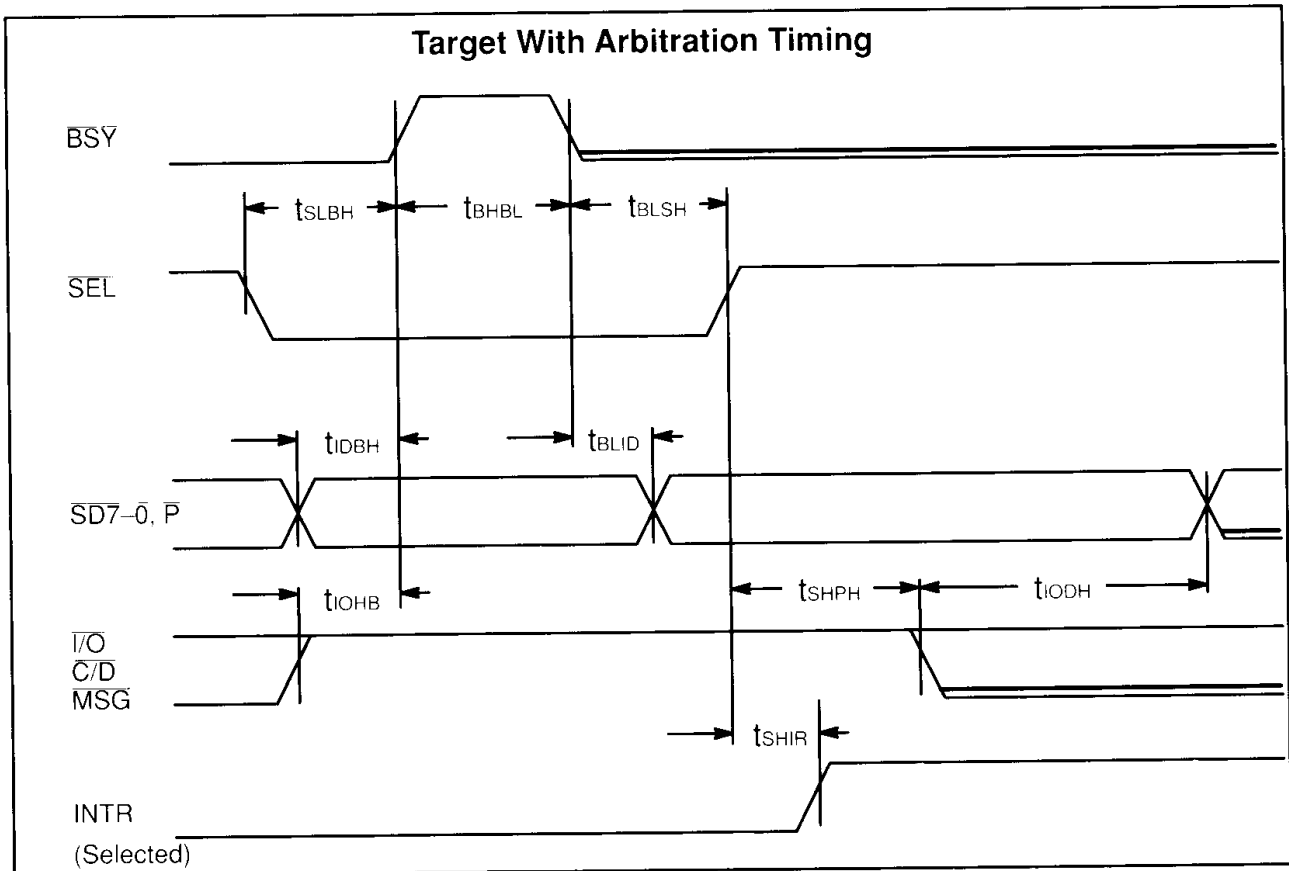

### AC CHARACTERISTICS (Continued)

TARGET — Selection Without Arbitration					
Parameter	Designator	Values			Unit
		Min.	Typ.	Max.	
Data Bus Valid (ID#) to $\overline{\text{SEL}}$ Low	$t_{\text{IDSL}}$	0			ns
I/O High to SEL Low	$t_{\text{IOHS}}$	0			ns
$\overline{\text{SEL}}$ Low to BSY Low	$t_{\text{SLBL}}$	$2t_{\text{CLF}}$		$3t_{\text{CLF}}+130$	ns
BSY Low to ID# Hold	$t_{\text{BLID}}$	60			ns
BSY Low to $\overline{\text{SEL}}$ High	$t_{\text{BLSH}}$	0			ns
$\overline{\text{SEL}}$ High to Phase Signal Output	$t_{\text{SHPH}}$	$3t_{\text{CLF}}$		$4t_{\text{CLF}}+160$	ns
I/O Low to Data Bus Output	$t_{\text{IODE}}$	$7t_{\text{CLF}}$			ns
$\overline{\text{SEL}}$ High to INTR High	$t_{\text{SHIR}}$			$3t_{\text{CLF}}+130$	ns

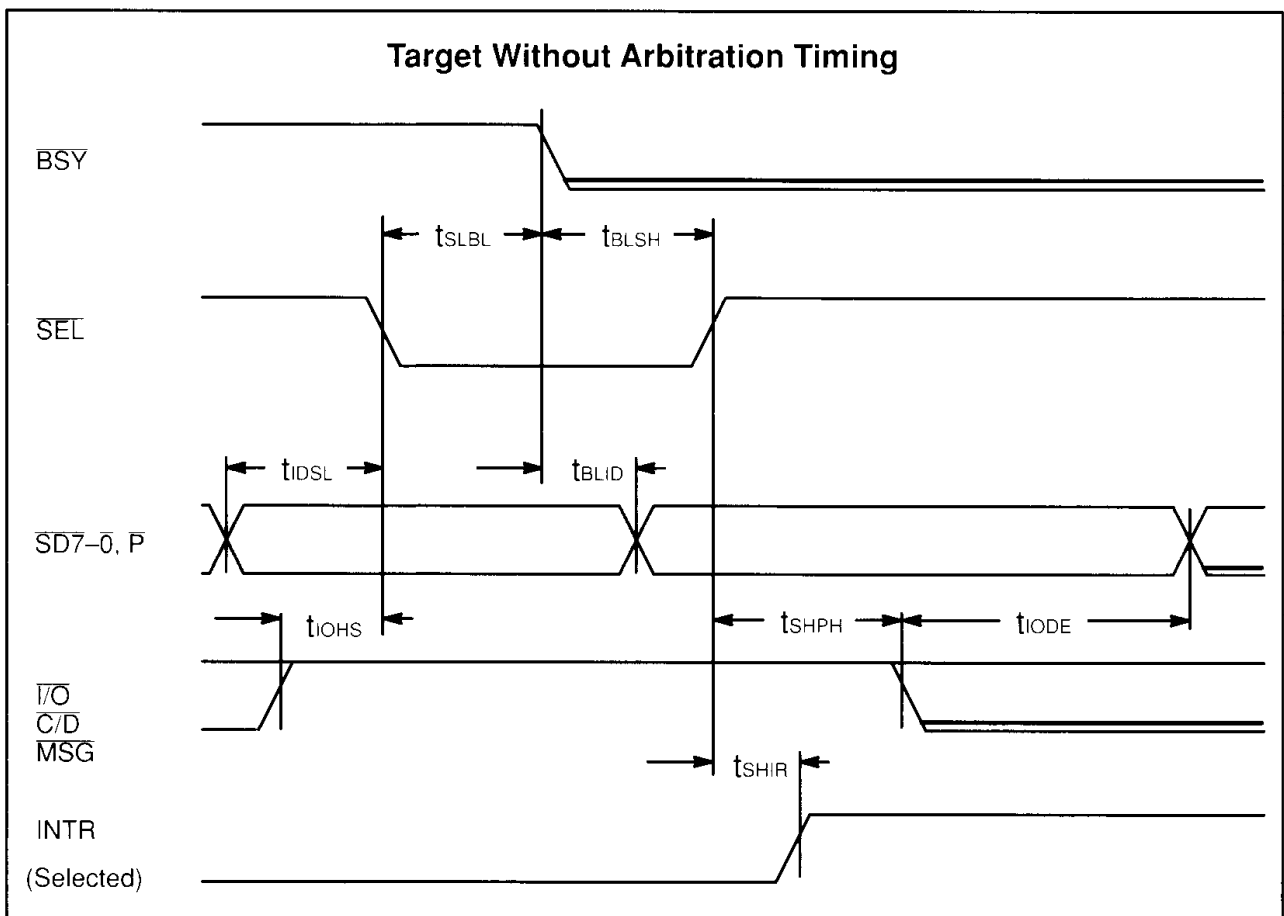

**AC CHARACTERISTICS** (Continued)**SCSI BUS INTERFACE – RESELECTION PHASE TIMING**

<b>TARGET — Reselection Phase Timing</b>					
Parameter	Designator	Values			Unit
		Min.	Typ.	Max.	
Bus Free Time <sup>*</sup>	t <sub>BFR</sub>	4t <sub>CLF</sub> +50			ns
Start of Arbitration	t <sub>BFBL</sub>	(6+n)** x t <sub>CLF</sub>		(7+n) x t <sub>CLF</sub> +140	ns
BSY Low to Self ID# Output	t <sub>BLID</sub>	0		60	ns
BSY Low to Prioritize	t <sub>ARB</sub>	32t <sub>CLF</sub> -60			ns
Data Bus Valid to Prioritize	t <sub>AIDV</sub>	200			ns
Bus Usage Permission Granted to SEL Low t <sub>AWSL</sub>	t <sub>AWSL</sub>	0		80	ns
SEL Low to Data Bus ID Output, Phase Signal Output	t <sub>SIDP</sub>	11t <sub>CLF</sub> -50			ns
Select ID# Output to BSY High	t <sub>IDBH</sub>	2t <sub>CLF</sub> -80			ns
BSY Low to BSY Low Output	t <sub>BIBO</sub>	2t <sub>CLF</sub> +20		3t <sub>CLF</sub> +140	ns
BSY Low to SEL High	t <sub>BLSH</sub>	2t <sub>CLF</sub>			ns
BSY Low to Select ID# Hold	t <sub>BIDH</sub>	2t <sub>CLF</sub>			ns
SEL High to INTR High	t <sub>SHIR</sub>			60	ns
SEL Low to BSY High, ID Bit High	t <sub>SBCR</sub>			3t <sub>CLF</sub> +180	ns
Prioritize to BSY High, ID Bit High	t <sub>PBCR</sub>			110	ns

Notes: <sup>\*</sup>Bus Free Time:=The minimum time period till the booked select command is executed.

<sup>\*\*</sup>n=TCL register value

### AC CHARACTERISTICS (Continued)

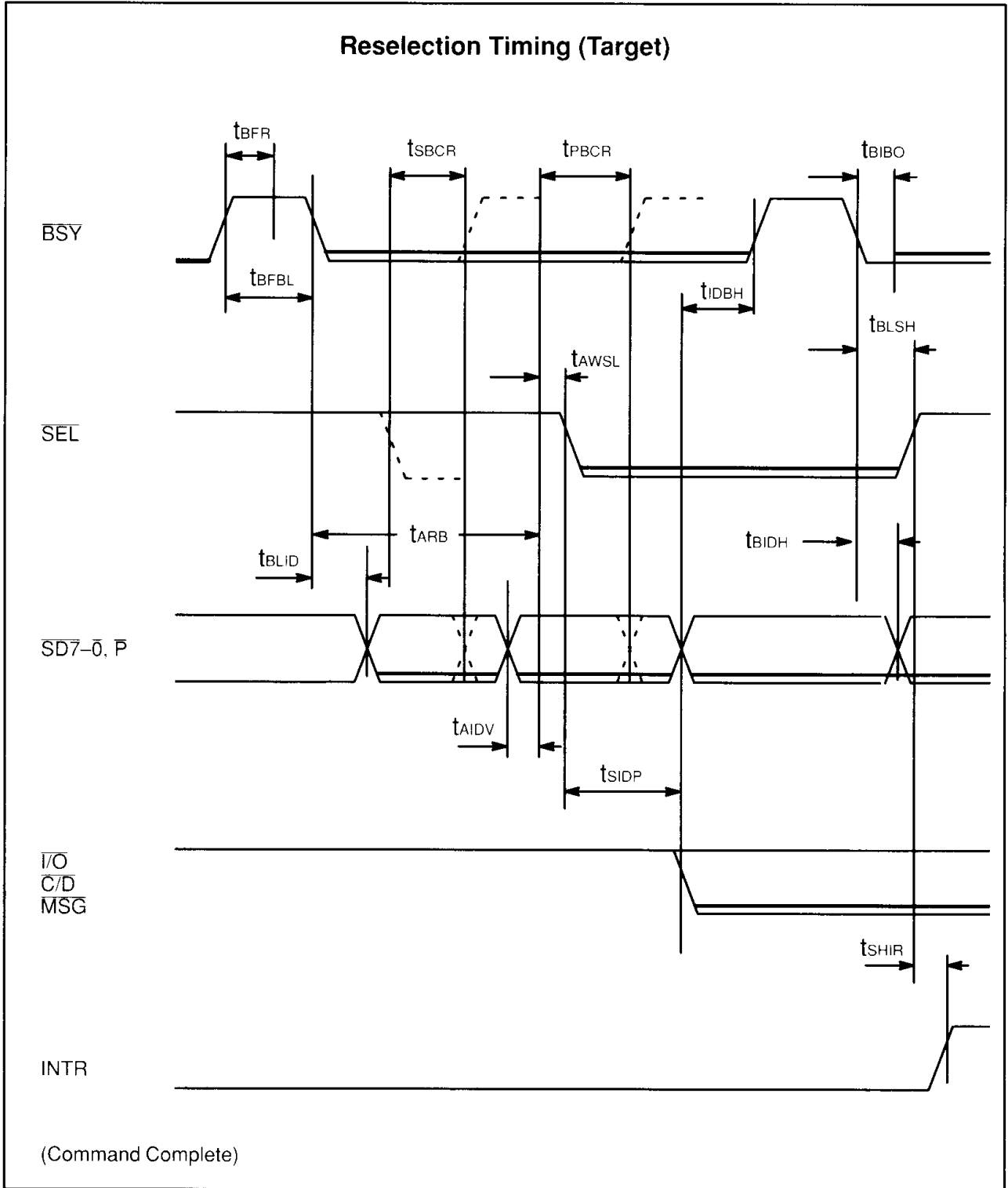

**AC CHARACTERISTICS** (Continued)

<b>INITIATOR — Reselection Phase Timing</b>					
Parameter	Designator	Values			Unit
		Min.	Typ.	Max.	
SEL Low to BSY High	$t_{SLBH}$	0			ns
Data Bus Valid (ID#) to BSY High	$t_{IDBH}$	0			ns
I/O Low to BSY High	$t_{IOLB}$	0			ns
BSY High to BSY Low	$t_{BHBL}$	$4t_{CLF}$		$5t_{CLF}+140$	ns
BSY Low to ID# Hold	$t_{BLID}$	60			ns
BSY Low to SEL High	$t_{BLSH}$	0			ns
SEL High to BSY Low Output	$t_{SHBO}$	$2t_{CLF}$		$3t_{CLF}+140$	ns
SEL High to Data Bus Valid (When I/O is High)	$t_{SHDE}$	$3t_{CLF}+30$		$4t_{CLF}+160$	ns
SEL High to I/O High	$t_{SHIO}$	200			ns
SEL High to INTR High	$t_{SHIR}$			$3t_{CLF}+130$	ns

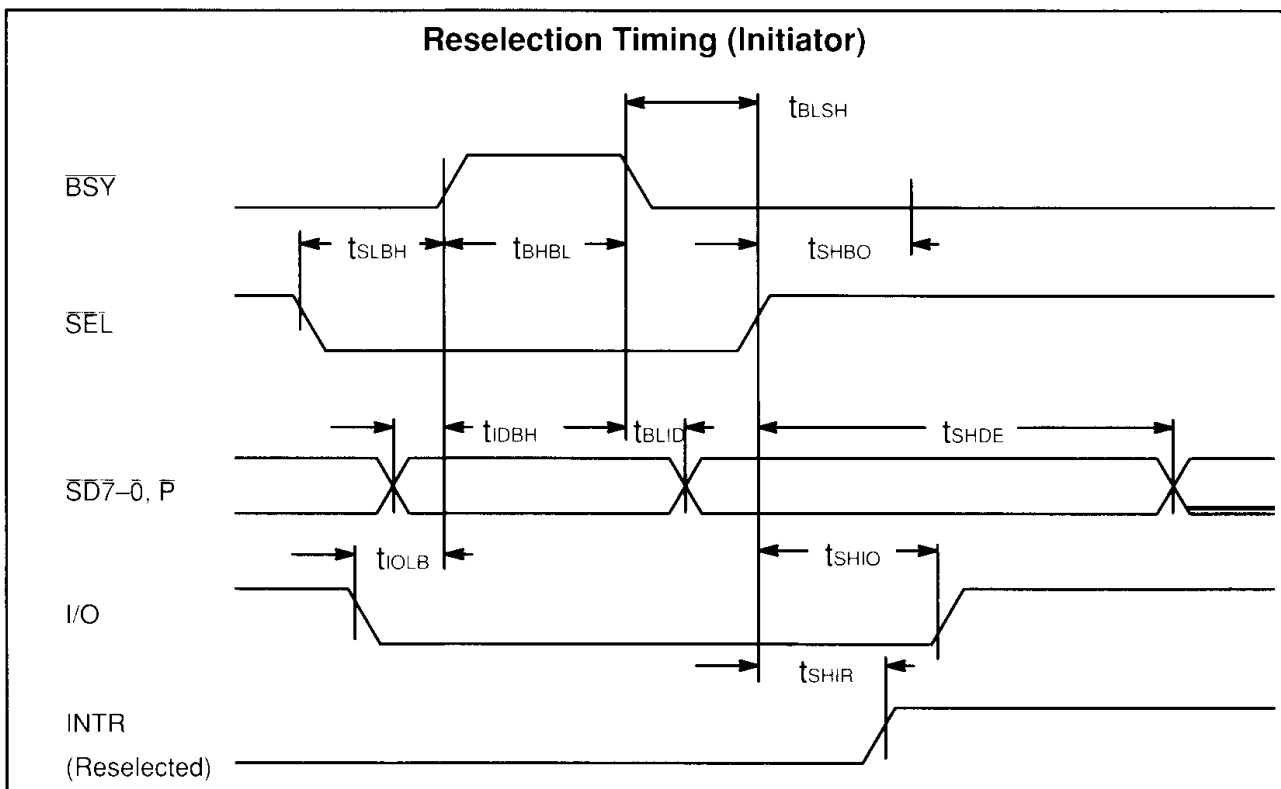

## AC CHARACTERISTICS (Continued)

### SCSI BUS INTERFACE – INFORMATION TRANSFER PHASE TIMING

INITIATOR —Asynchronous Transfer Output					
Parameter	Designator	Values			Unit
		Min.	Typ.	Max.	
$\overline{I/O}$ High to Data Bus Output	$t_{IIDE}$	10			ns
Phase Set to $\overline{REQ}$ Low	$t_{PHRL}$	100			ns
$REQ$ Low to $\overline{ACK}$ Low	$t_{RAOL}$	20			ns
Data Bus Valid to $\overline{ACK}$ Low	$t_{DVLD}$	$2t_{CLF}-80$			ns
$\overline{ACK}$ Low to $\overline{REQ}$ High	$t_{AOLR}$	0			ns
$\overline{REQ}$ High to $\overline{ACK}$ High	$t_{RAOH}$	10			ns
$\overline{ACK}$ High to $\overline{REQ}$ Low	$t_{AOHR}$	0			ns
$REQ$ High to $\overline{ACK}$ Low	$t_{RACY}$	$2t_{CLF}$			ns
$REQ$ High to Data Bus Hold	$t_{DIVD}$	15			ns
$\overline{REQ}$ Low to $\overline{ATN}$ High <sup>1</sup>	$t_{RATH}$	$2t_{CLF}$			ns
$\overline{ATN}$ High to $\overline{ACK}$ Low <sup>1</sup>	$t_{ATHA}$	$t_{CLF}-20$			ns
$\overline{REQ}$ Low to Phase Change <sup>2</sup>	$t_{RLPH}$	$3t_{CLF}$			ns
$\overline{ACK}$ High to Phase Change <sup>2</sup>	$t_{AHPH}$	10			ns

Notes: 1 This spec is applicable to the last byte transfer of message out phase in hardware transfer mode.

2 When the transfer phase is changed, both  $t_{RLPH}$  and  $t_{ALPH}$  should be specified.



**AC CHARACTERISTICS** (Continued)

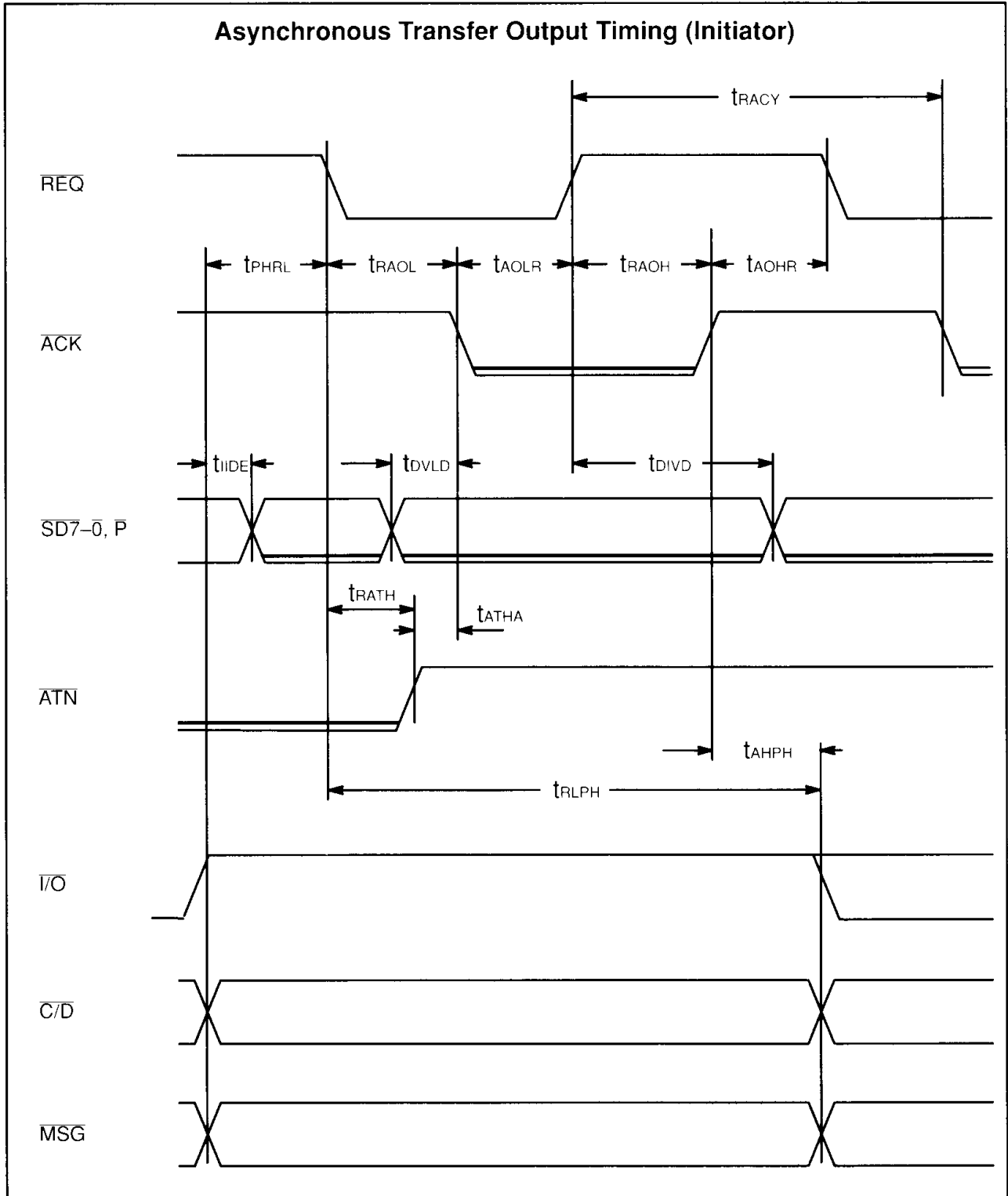

### AC CHARACTERISTICS (Continued)

TARGET —Asynchronous Transfer Output					
Parameter	Designator	Values			Unit
		Min.	Typ.	Max.	
I/O Low to Data Bus Output	$t_{IODE}$	$7t_{CLF}$			ns
Data Bus Valid to REQ Low	$t_{DVLD}$	$2t_{CLF}-80$			ns
ACK Low to Data Bus Hold	$t_{DIVD}$	15			ns
REQ Low to ACK Low	$t_{ROLA}$	0			ns
ACK Low to REQ High	$t_{AROH}$	10		180	ns
REQ High to ACK High	$t_{ROHA}$	0			ns
ACK High to REQ Low	$t_{AROL}$	10			ns
ACK Low to REQ Low	$t_{RACY}$	$2t_{CLF}$			ns

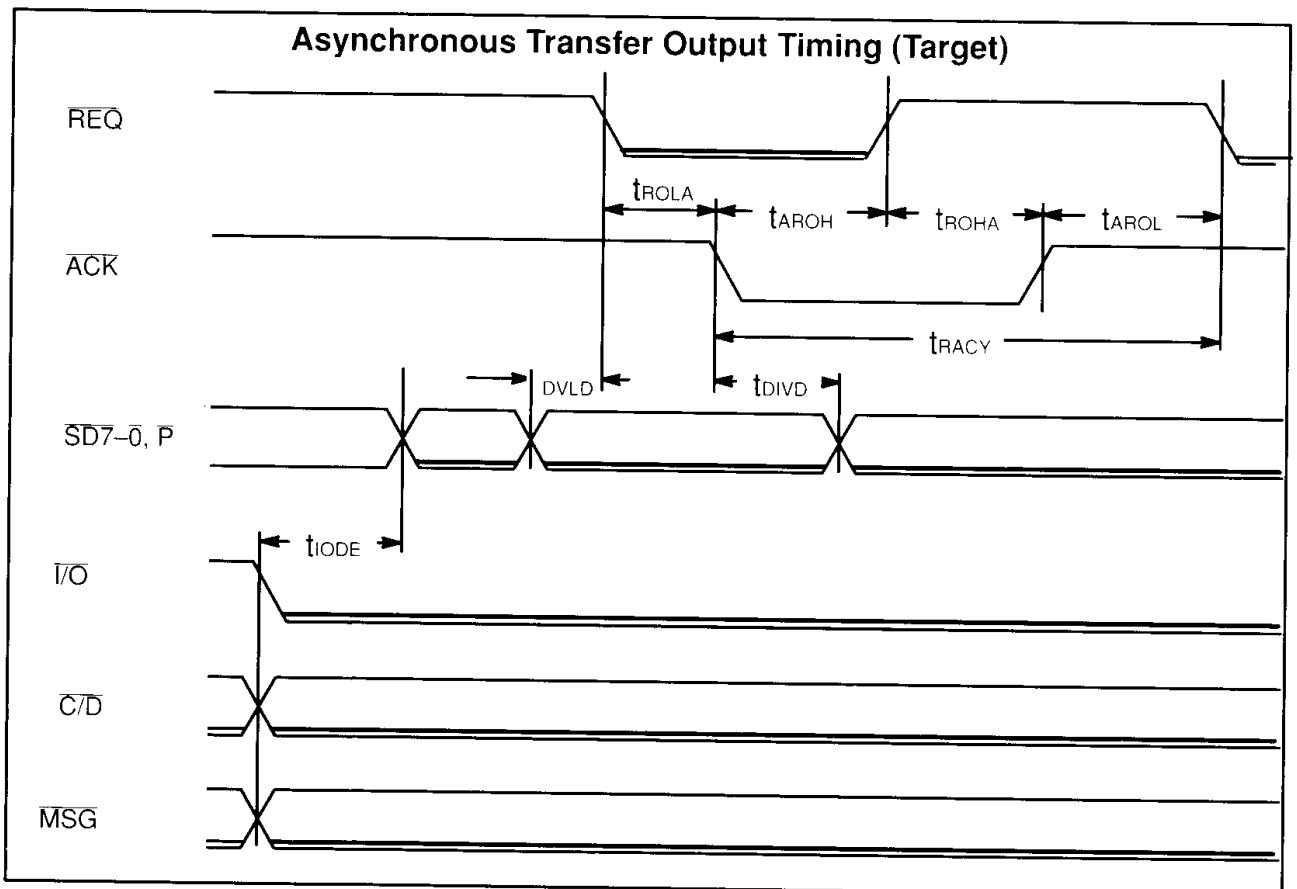

**AC CHARACTERISTICS** (Continued)

<b>INITIATOR —Asynchronous Transfer Input</b>					
Parameter	Designator	Values			Unit
		Min.	Typ.	Max.	
I/O Low to Data Bus Output Terminate	$t_{I\bar{O}D}$			140	ns
Phase Set to $\overline{REQ}$ Low	$t_{PHRL}$	100			ns
Data Bus Valid to $\overline{REQ}$ Low	$t_{DSTU}$	10			ns
$\overline{REQ}$ Low to $\overline{ACK}$ Low	$t_{RAOL}$	20			ns
$\overline{ACK}$ Low to $\overline{REQ}$ High	$t_{AOLR}$	0			ns
$\overline{ACK}$ Low to Data Bus Hold	$t_{DHLD}$	15			ns
$\overline{REQ}$ High to $\overline{ACK}$ High	$t_{RAOH}$	10			ns
$\overline{ACK}$ High to $\overline{REQ}$ Low	$t_{AOHR}$	0			ns
$\overline{REQ}$ High to $\overline{ACK}$ Low	$t_{RACY}$	$2t_{CLF}$			ns
$\overline{ATN}$ Low to $\overline{ACK}$ High <sup>1</sup>	$t_{ATAH}$	$t_{CLF}-20$			ns
$\overline{REQ}$ Low to Phase Change <sup>2</sup>	$t_{RLPH}$	$3t_{CLF}$			ns
$\overline{ACK}$ High to Phase Change <sup>2</sup>	$t_{AHPH}$	10			ns

Notes: 1 Applicable to the last byte transfer of message out phase in hardware transfer mode.

2 When the transfer phase is changed, both  $t_{RLPH}$  and  $t_{AHPH}$  should be specified.

**AC CHARACTERISTICS (Continued)**

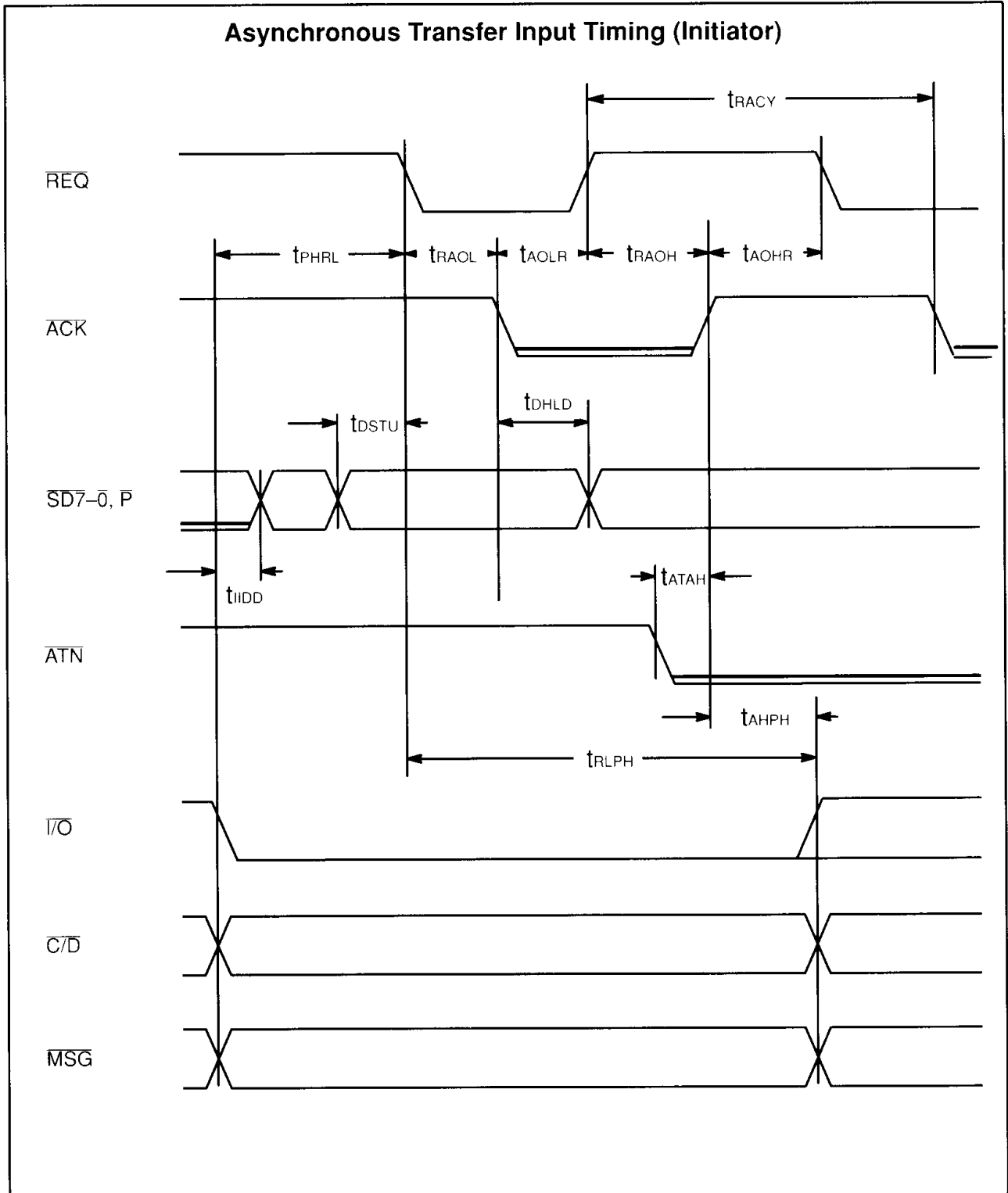

### AC CHARACTERISTICS (Continued)

TARGET — Asynchronous Transfer Input					
Parameter	Designator	Values			Unit
		Min.	Typ.	Max.	
I/O High to Data Bus Output Terminate	t <sub>IODD</sub>			30	ns
Data Bus Valid to $\overline{\text{ACK}}$ Low	t <sub>DSTU</sub>	10			ns
$\overline{\text{REQ}}$ High to Data Bus Hold	t <sub>DHLD</sub>	15			ns
REQ Low to ACK Low	t <sub>ROLA</sub>	0			ns
ACK Low to REQ High	t <sub>AROH</sub>	10		180	ns
REQ High to $\overline{\text{ACK}}$ High	t <sub>ROHA</sub>	0			ns
$\overline{\text{ACK}}$ High to REQ Low	t <sub>AROL</sub>	10			ns
$\overline{\text{ACK}}$ Low to $\overline{\text{REQ}}$ Low	t <sub>RACY</sub>	2t <sub>CLF</sub>			ns

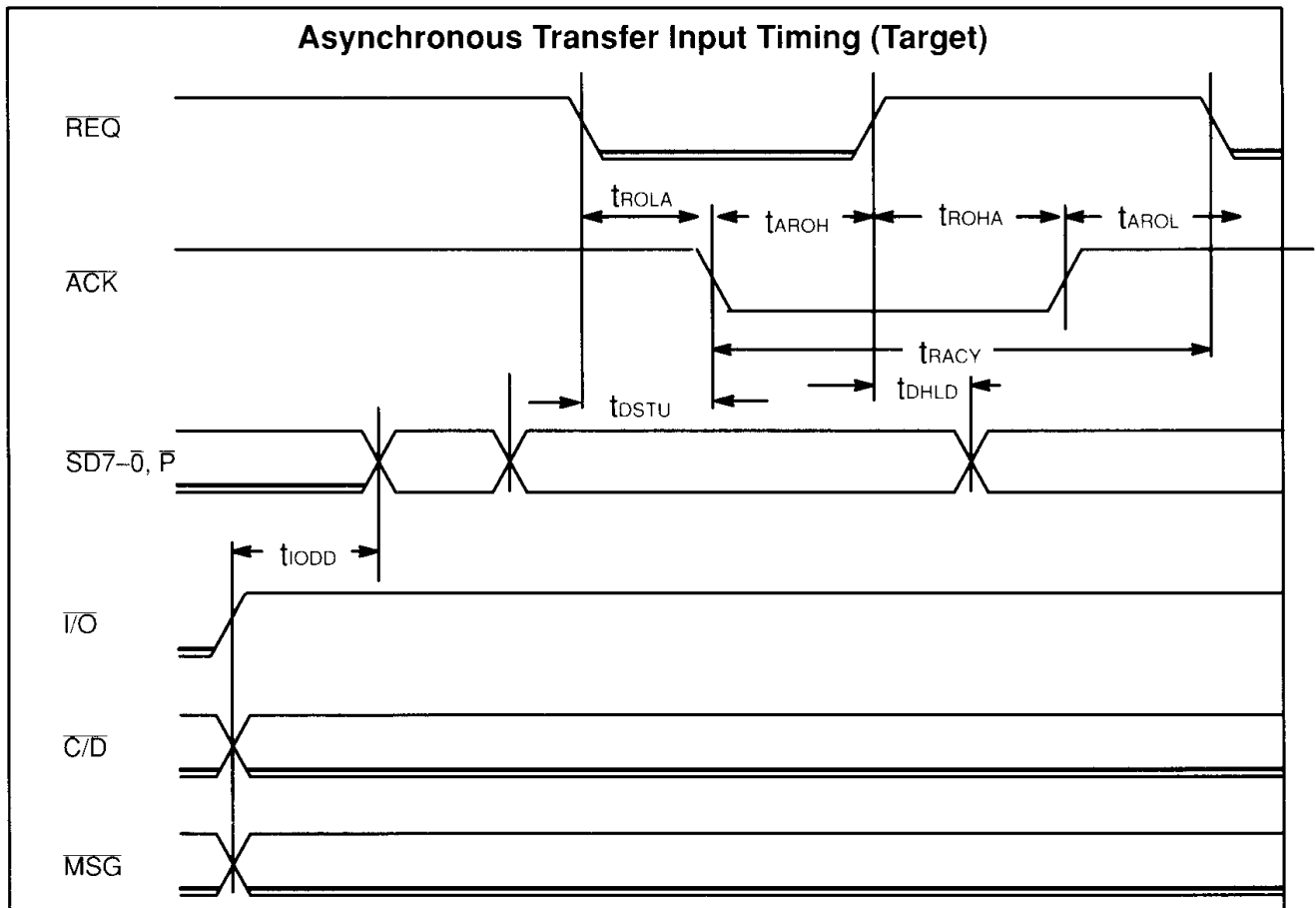

### AC CHARACTERISTICS (Continued)

Transfer Phase Change (Target)					
Parameter	Designator	Values			Unit
		Min.	Typ.	Max.	
From WR High to MSG, C/D, I/O change	$t_{PHCH}$	10		130	ns

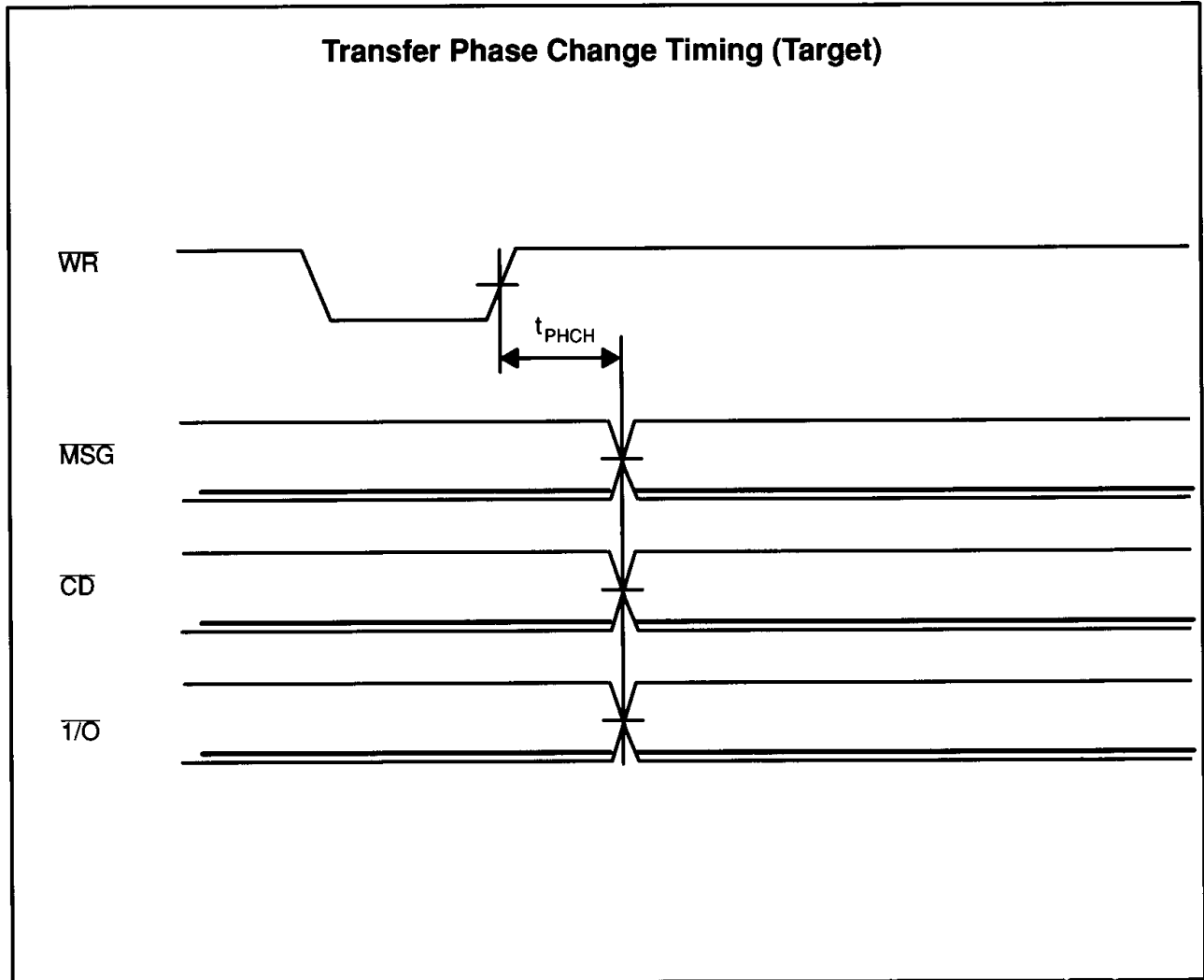

### AC CHARACTERISTICS (Continued)

Manual Transfer					
Parameter	Designator	Values			Unit
		Min.	Typ.	Max.	
From $\overline{WR}$ High to Data Bus Valid for TEMP Register	$t_{WRDV}$			130	ns
From $\overline{WR}$ High to REQ Low, ACK Low for SET ACK/REQ Command	$t_{STRA}$	$2t_{CLF}$		$3t_{CLF} + 90$	ns
From $\overline{WR}$ High to REQ High, ACK High for RESET ACK/REQ Command	$t_{RTRA}$	$2t_{CLF}$		$3t_{CLF} + 90$	ns

**Note:** Timing relationships not shown are the same as those for asynchronous transfers.

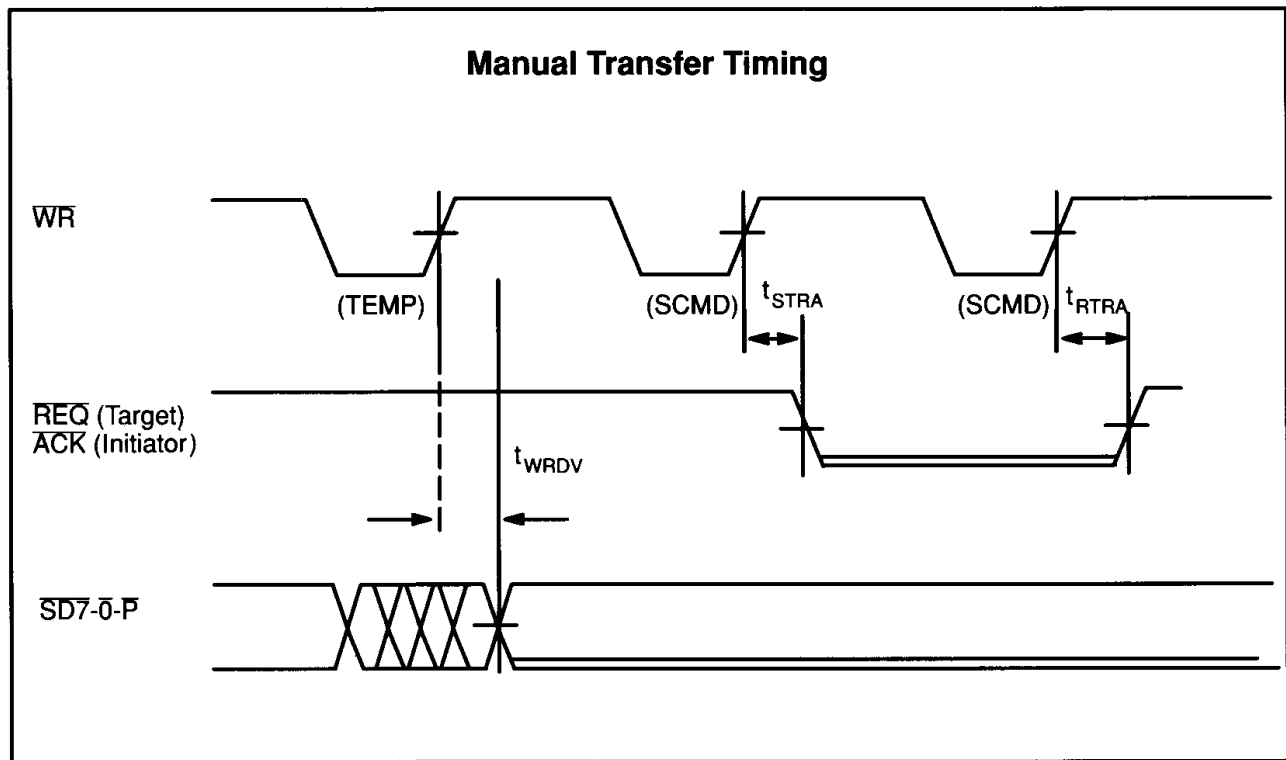

## AC CHARACTERISTICS (Continued)

### SCSI BUS INTERFACE – ATTENTION CONDITION

INITIATOR - Attention Condition					
Parameter	Designator	Values			Unit
		Min.	Typ.	Max.	
From $\overline{WR}$ High to $\overline{ATN}$ Change (SET/RESET ATN Command)	$t_{WATN}$	$2t_{CLF}$		$3t_{CLF} + 90$	ns

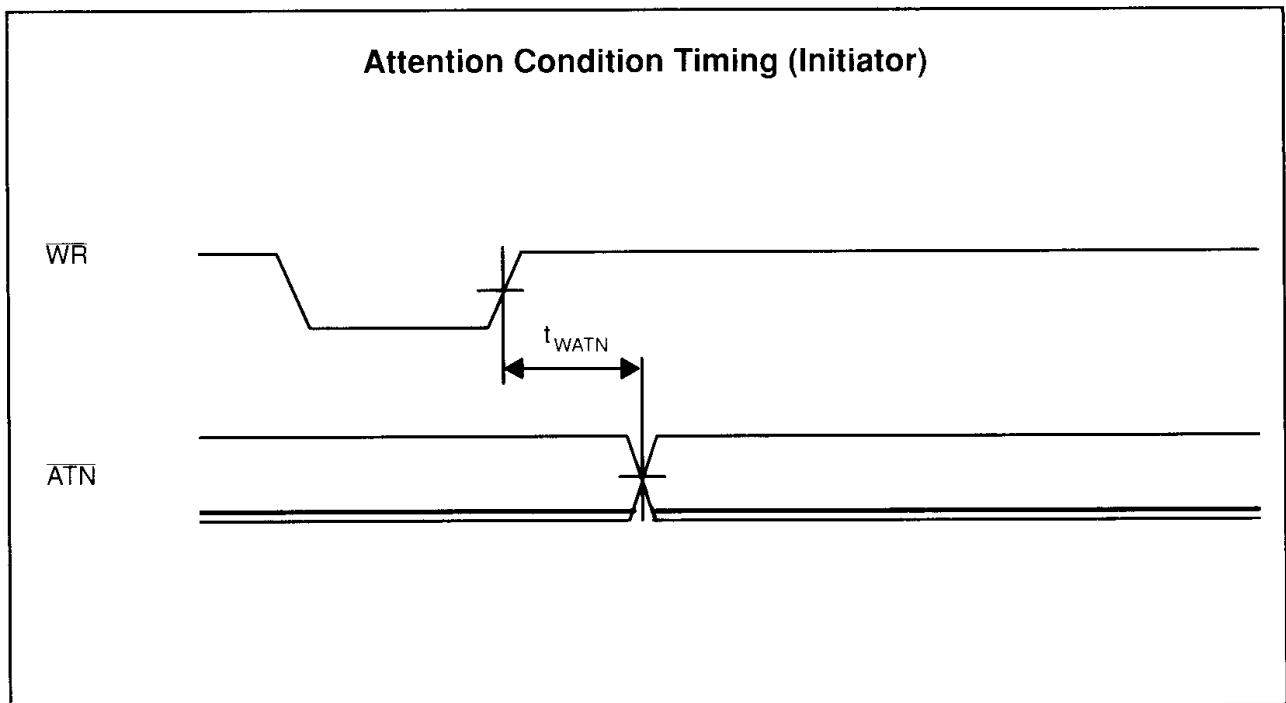



## AC CHARACTERISTICS (Continued)

### SCSI BUS INTERFACE – BUS FREE

INITIATOR — Bus Free (Disconnection)					
Parameter	Designator	Values			Unit
		Min.	Typ.	Max.	
BSY High to Bus Clear	$t_{BHCR}$			$5t_{CLF}+140$	ns
BSY High to INTR High	$t_{BHIR}$			$6t_{CLF}+80$	ns

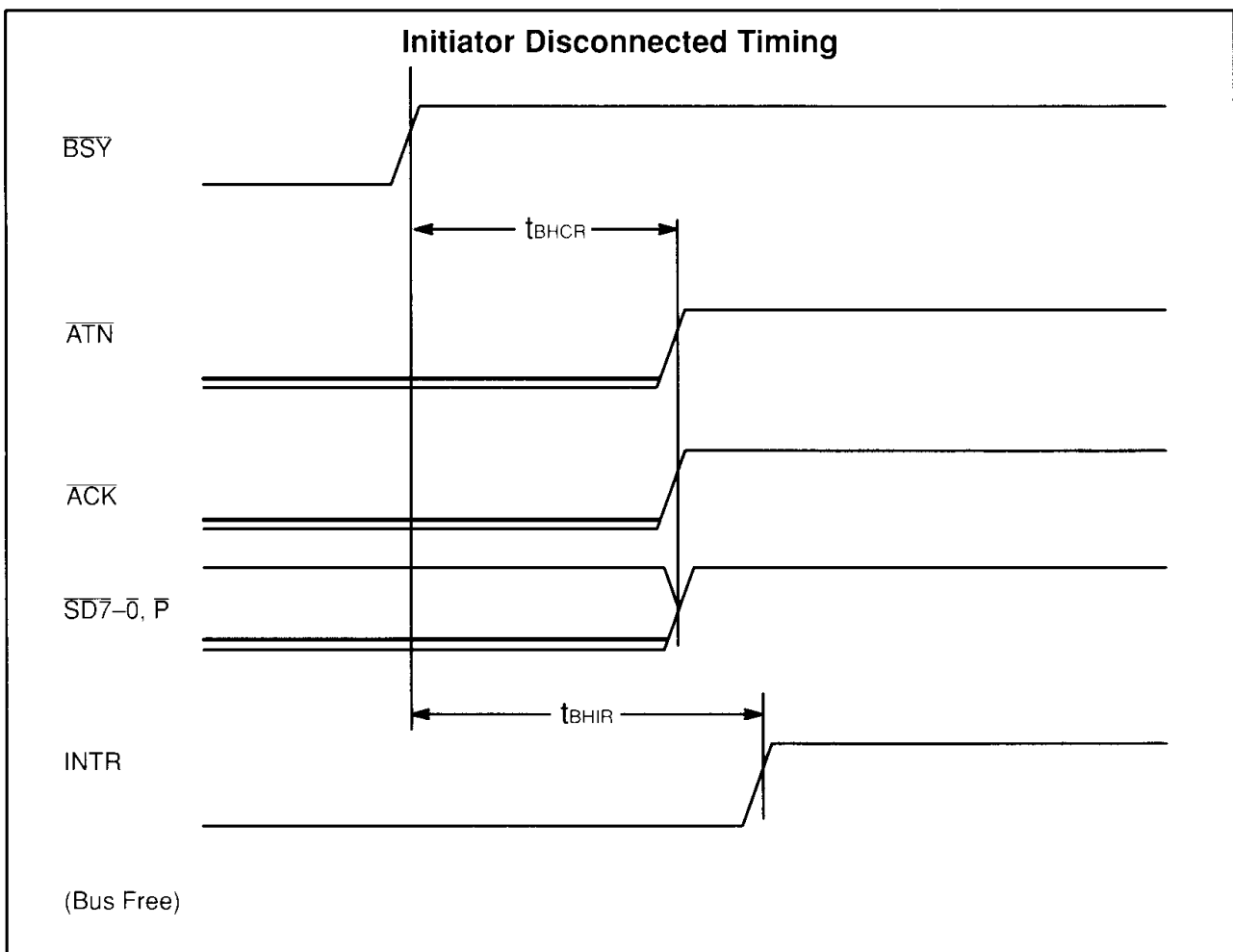

### AC CHARACTERISTICS (Continued)

TARGET (Bus Release Command)					
Parameter	Designator	Values			Unit
		Min.	Typ.	Max.	
WR High to Bus Clear (Bus Release Command)	$t_{BRCR}$			$3t_{CLF}+100$	ns

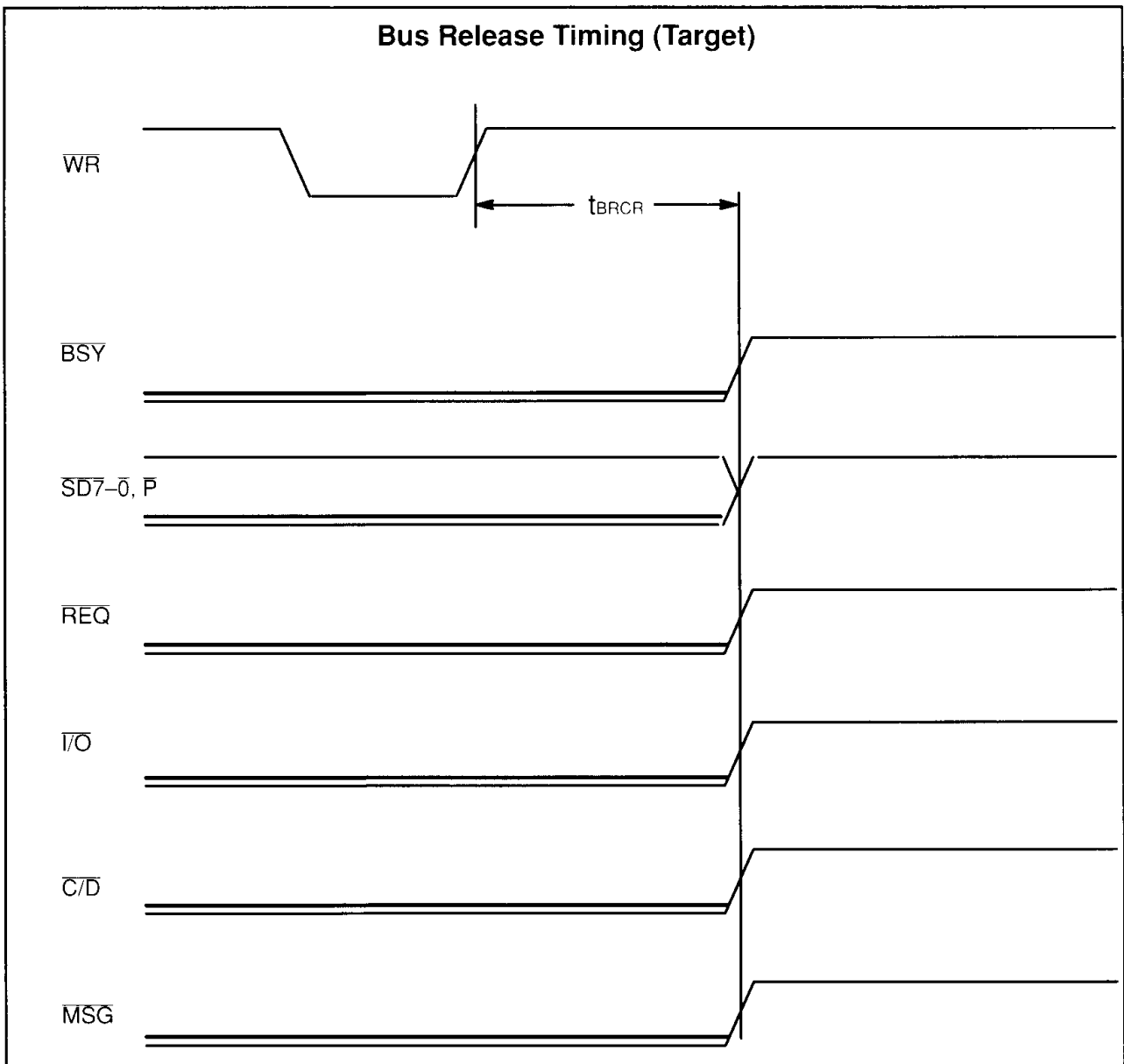

### AC CHARACTERISTICS (Continued)

TERMINATION (Time Out) – Selection and Reselection Phases					
Parameter	Designator	Values			Unit
		Min.	Typ.	Max.	
WR High to $\overline{\text{SEL}}$ , $\overline{\text{SD7-0}}$ , P, $\overline{\text{I/O}}$ High (Reset Time Out Interruption)	$t_{\text{BRCR}}$			$3t_{\text{CLF}}+100$	ns ns
WR High to INTR Low	$t_{\text{WRIR}}$			$3t_{\text{CLF}}+60$	ns

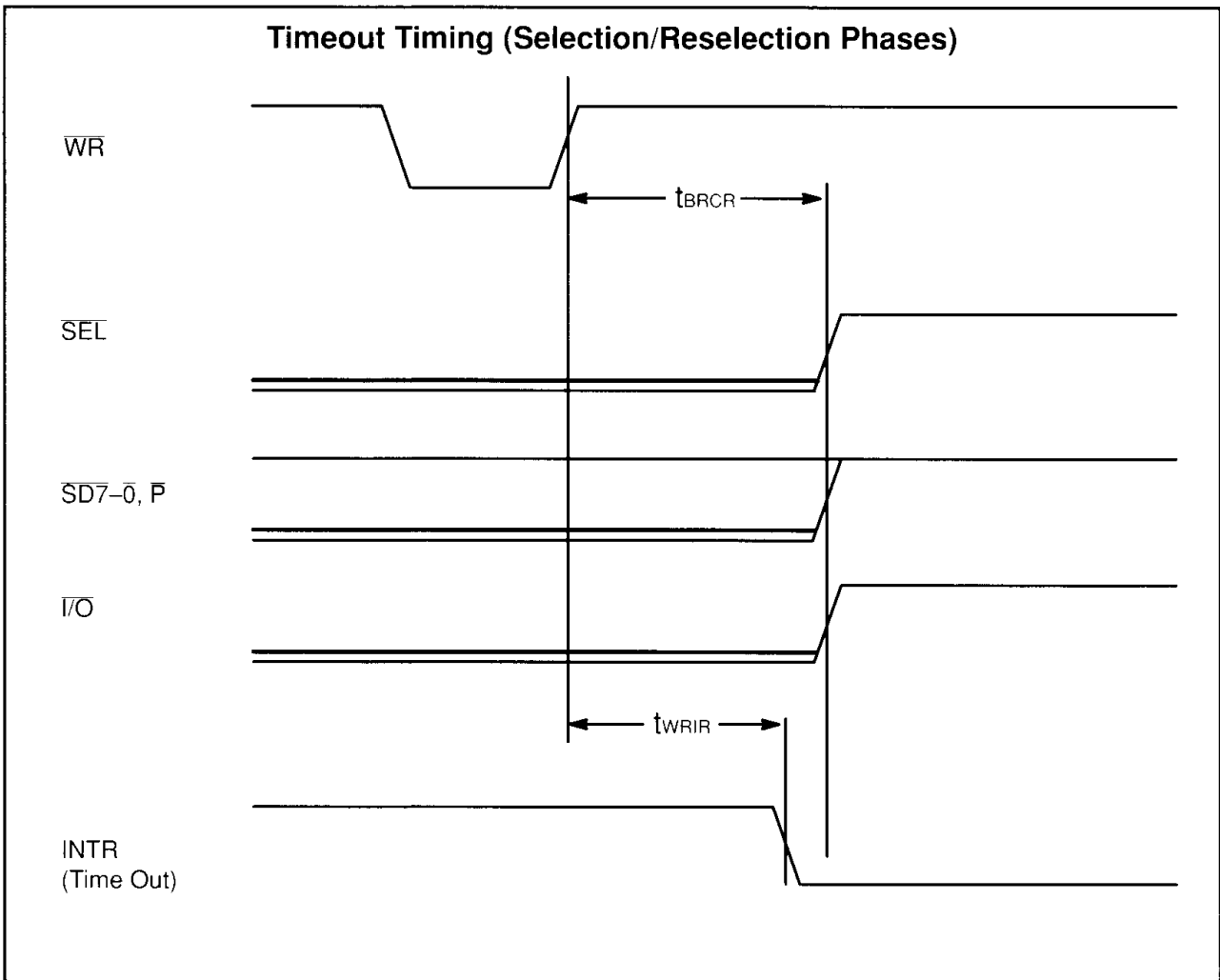

## AC CHARACTERISTICS (Continued)

### SCSI BUS INTERFACE – RESET CONDITION

SRST – Reset Condition (Output)					
Parameter	Designator	Values			Unit
		Min.	Typ.	Max.	
WR High to SRST Low (Write "1" to SCMD Bit-4)	$t_{WRST}$	10		110	ns
Reset Delay	$t_{RTSD}$			140	ns

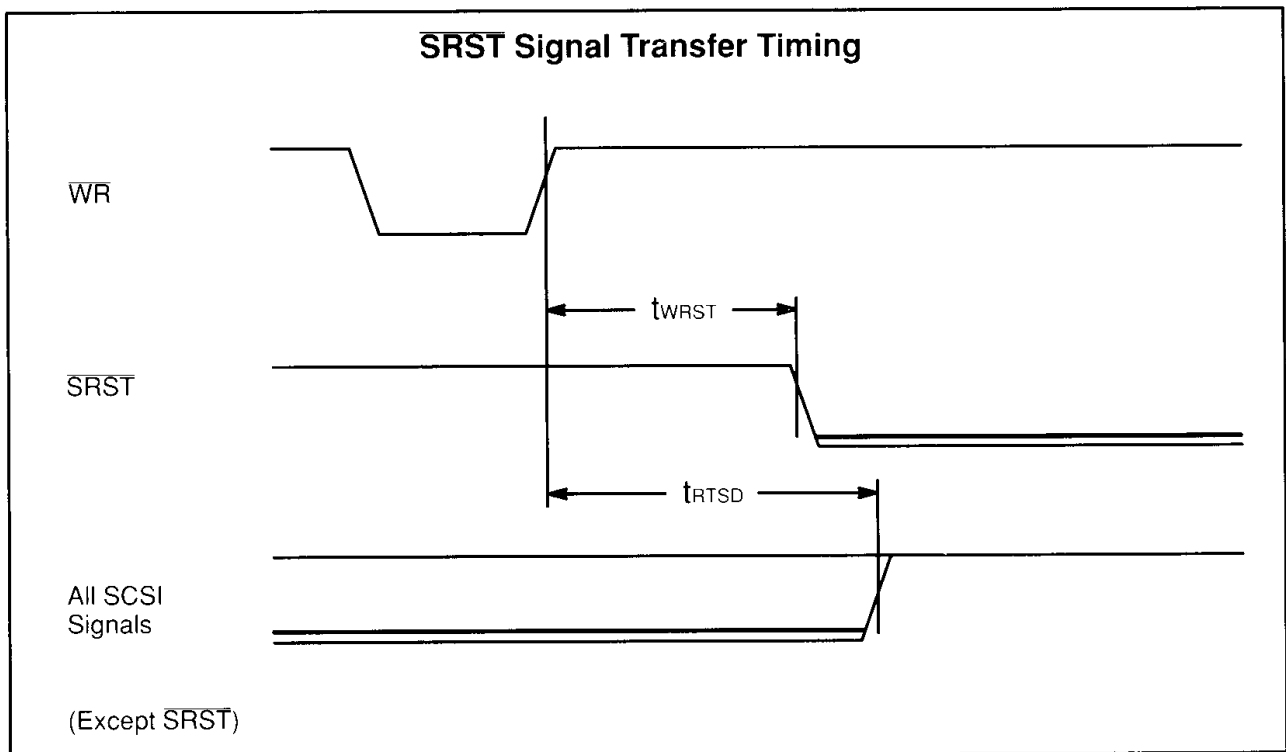

## AC CHARACTERISTICS (Continued)

### SCSI BUS INTERFACE – RESET CONDITION

SRST – Reset Condition (Input)					
Parameter	Designator	Values			Unit
		Min.	Typ.	Max.	
SRST Pulse Width	$t_{RSTW}$	$3t_{CLF}$			ns
Reset Delay	$t_{RTID}$			$4t_{CLF} + 200$	ns

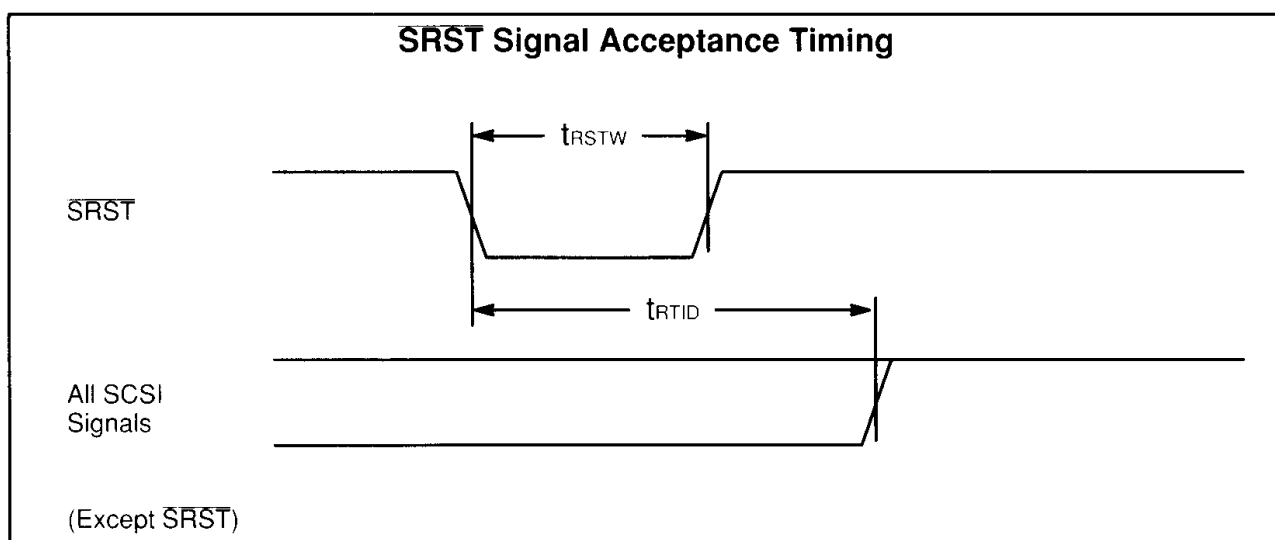

### AC CHARACTERISTICS (Continued)

Capacitance			
Parameter	Values		Unit
	Typ.	Max.	
D7 – D0, DP	—	80	pF
DPO, INTR, DREQ	10	30	pF
SD7 - SDO, SDP	—	300	pF
SRST, SEL, BSY, I/O, C/D, MSG, REQ, ACK, ATN	—	300	pF

The AC characteristics of all SCSI bus signal pins are measured on the following test circuit.

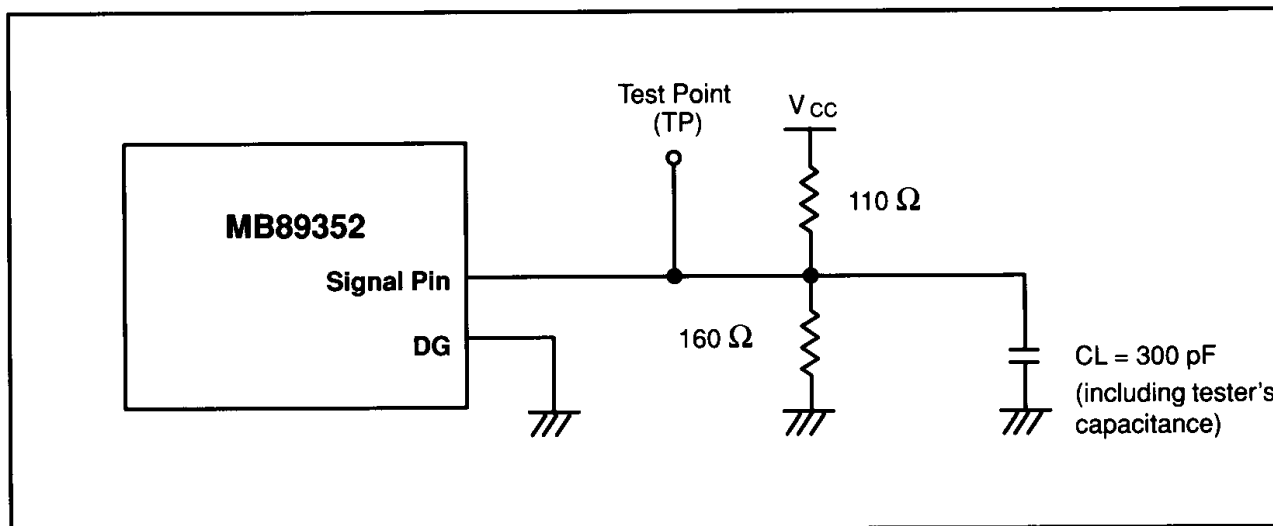

# PACKAGE DIMENSIONS

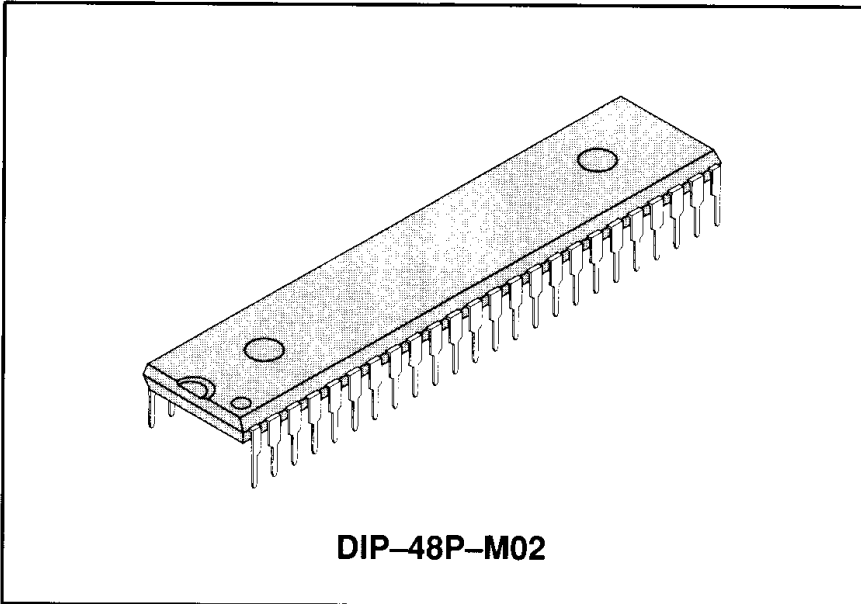

## 48-LEAD PLASTIC DUAL-IN-LINE PACKAGE (CASE NO.: DIP-48P-M02)

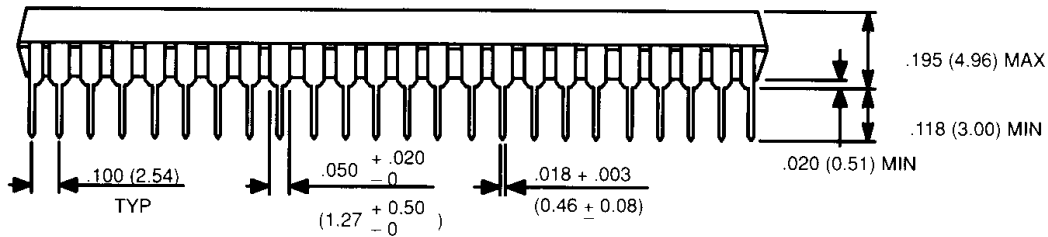
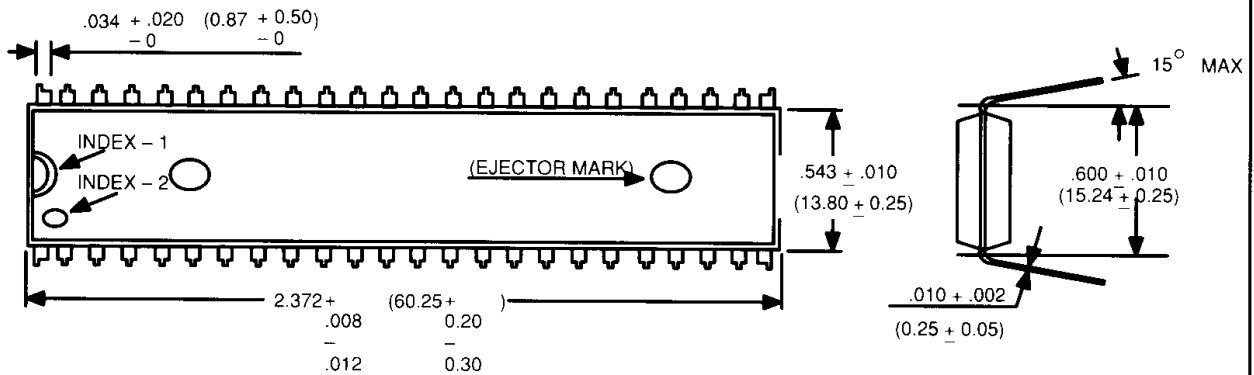

Dimensions in  
inches (millimeters)

D48003S-2C

# PACKAGE DIMENSIONS

## 48-Lead Plastic Flat Package

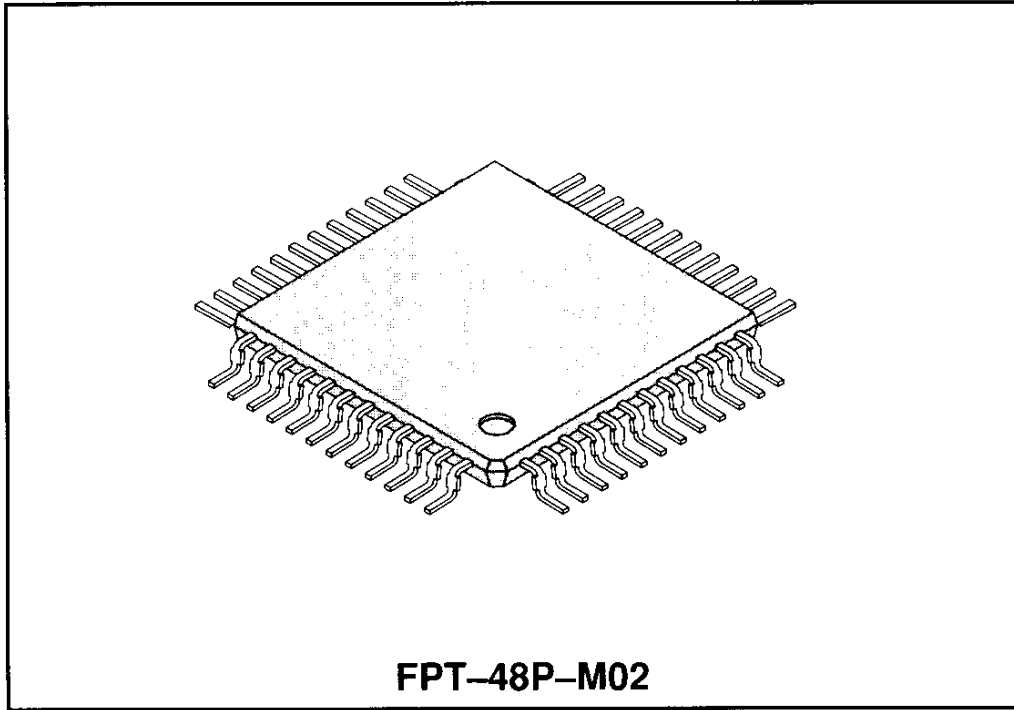

### 48-LEAD PLASTIC FLAT PACKAGE (CASE NO.: FPT-48P-M02)

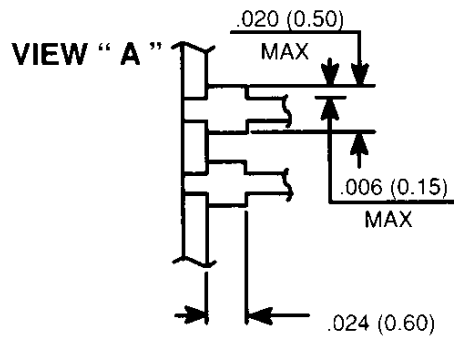
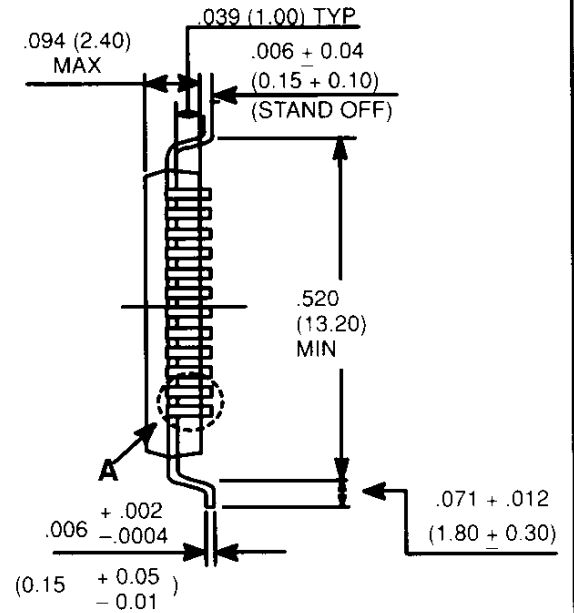
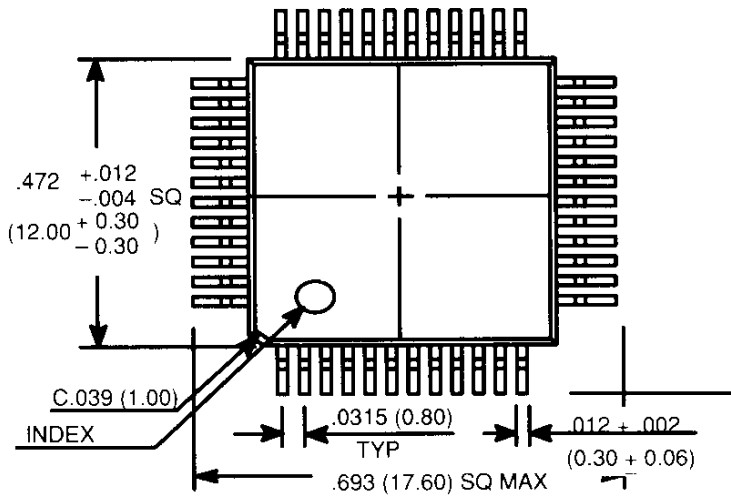

Dimensions in  
inches (millimeters)

F48002S-5C