

16-bit Proprietary Microcontroller

CMOS

F²MC-16LX MB90595/595G Series

MB90598/F598/F598G/V595/V595G

■ DESCRIPTION

The MB90595/595G series with FULL-CAN*1 interface and FLASH ROM is especially designed for automotive and industrial applications. Its main features are two on board CAN Interfaces, which conform to V2.0 Part A and Part B, while supporting a very flexible message buffer scheme and so offering more functions than a normal full CAN approach.

The instruction set of F²MC-16LX CPU core inherits an AT architecture of the F²MC*2 family with additional instruction sets for high-level languages, extended addressing mode, enhanced multiplication/division instructions, and enhanced bit manipulation instructions. The microcontroller has a 32-bit accumulator for processing long word data.

The MB90595/595G series has peripheral resources of 8/10-bit A/D converters, UART (SCI), extended I/O serial interface, 8/16-bit PPG timer, I/O timer (input capture (ICU), output compare (OCU)) and stepping motor controller.

*1: Controller Area Network (CAN) - License of Robert Bosch GmbH

*2: F²MC stands for FUJITSU Flexible Microcontroller.

■ FEATURES

- Clock
 - Embedded PLL clock multiplication circuit
 - Operating clock (PLL clock) can be selected from divided-by-2 of oscillation or one to four times the oscillation (at oscillation of 4 MHz, 4 MHz to 16 MHz).
 - Minimum instruction execution time: 62.5 ns (operation at oscillation of 4 MHz, four times the oscillation clock, V_{cc} of 5.0 V)

(Continued)

■ PACKAGE

100-pin Plastic QFP

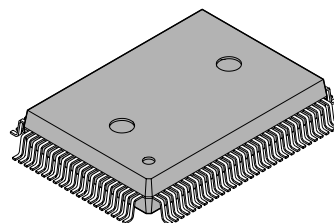

(FPT-100P-M06)

MB90595/595G Series

(Continued)

- Instruction set to optimize controller applications
 - Rich data types (bit, byte, word, long word)
 - Rich addressing mode (23 types)
 - Enhanced signed multiplication/division instruction and RETI instruction functions
 - Enhanced precision calculation realized by the 32-bit accumulator
- Instruction set designed for high level language (C language) and multi-task operations
 - Adoption of system stack pointer
 - Enhanced pointer indirect instructions
 - Barrel shift instructions
- Program patch function (for two address pointers)
- Enhanced execution speed: 4-byte instruction queue
- Enhanced interrupt function: 8 levels, 34 factors
- Automatic data transmission function independent of CPU operation
 - Extended intelligent I/O service function (EI²OS): Up to 10 channels
- Embedded ROM size and types
 - Mask ROM: 128 Kbytes
 - Flash ROM: 128 Kbytes
 - Embedded RAM size: 4 Kbytes (MB90V595/595G : 6 Kbytes)
- Flash ROM
 - Supports automatic programming, Embedded Algorithm ™*
 - Write/Erase/Erase-Suspend/Resume commands
 - A flag indicating completion of the algorithm
 - Hard-wired reset vector available in order to point to a fixed boot sector
 - Erase can be performed on each block
 - Block protection with external programming voltage
- Low-power consumption (stand-by) mode
 - Sleep mode (mode in which CPU operating clock is stopped)
 - Stop mode (mode in which oscillation is stopped)
 - CPU intermittent operation mode
 - Hardware stand-by mode
- Process: 0.5 μm CMOS technology
- I/O port
 - General-purpose I/O ports: 78 ports
 - Push-pull output and Schmitt trigger input.
 - Programmable on each bit as I/O or signal for peripherals.
- Timer
 - Watchdog timer: 1 channel
 - 8/16-bit PPG timer: 8/16-bit × 6 channels
 - 16-bit re-load timer: 2 channels
- 16-bit I/O timer
 - Input capture: 4 channels
 - Output compare: 4 channels
- Extended I/O serial interface: 1 channel
- UART0
 - With full-duplex double buffer (8-bit length)
 - Clock asynchronous or clock synchronized (with start/stop bit) transmission can be selectively used.

MB90595/595G Series

- UART1 (SCI)
With full-duplex double buffer (8-bit length)
Clock asynchronous or clock synchronized serial transmission (I/O extended transmission) can be selectively used.
- Stepping motor controller (4 channels)
- External interrupt circuit (8 channels)
A module for starting an extended intelligent I/O service (EI²OS) and generating an external interrupt which is triggered by an external input.
- Delayed interrupt generation module: Generates an interrupt request for switching tasks.
- 8/10-bit A/D converter (8 channels)
8/10-bit resolution can be selectively used.
Starting by an external trigger input.
- FULL-CAN interface: 1 channel
Conforming to Version 2.0 Part A and Part B
Flexible message buffering (mailbox and FIFO buffering can be mixed)
- 18-bit Time-base counter
- External bus interface: Maximum address space 16 Mbytes

*: Embedded Algorithm is a trademark of Advanced Micro Devices Inc.

MB90595/595G Series

■ PRODUCT LINEUP

Features		MB90598	MB90F598/F598G	MB90V595/V595G
Classification		Mask ROM product	Flash ROM product	Evaluation product
ROM size		128 Kbytes	128 Kbytes Boot block Hard-wired reset vector	None
RAM size		4 Kbytes	4 Kbytes	6 Kbytes
Emulator-specific power supply *1		—		None
CPU functions		The number of instructions: 351 Instruction bit length: 8 bits, 16 bits Instruction length: 1 byte to 7 bytes Data bit length: 1 bit, 8 bits, 16 bits Minimum execution time: 62.5 ns (at machine clock frequency of 16 MHz) Interrupt processing time: 1.5 μs (at machine clock frequency of 16 MHz, minimum value)		
UART0		Clock synchronized transmission (500 K/1 M/2 Mbps) Clock asynchronized transmission (4808/5208/9615/10417/19230/38460/62500 /500000 bps at machine clock frequency of 16 MHz) Transmission can be performed by bi-directional serial transmission or by master/slave connection.		
UART1(SCI)		Clock synchronized transmission (62.5 K/125 K/250 K/500 K/1 Mbps) Clock asynchronized transmission (1202/2404/4808/9615/31250 bps) Transmission can be performed by bi-directional serial transmission or by master/slave connection.		
8/10-bit A/D converter		Conversion precision: 8/10-bit can be selectively used. Number of inputs: 8 One-shot conversion mode (converts selected channel once only) Scan conversion mode (converts two or more successive channels and can program up to 8 channels) Continuous conversion mode (converts selected channel continuously) Stop conversion mode (converts selected channel and stop operation repeatedly)		
8/16-bit PPG timers (6 channels)		Number of channels: 6 (8/16-bit × 6 channels) PPG operation of 8-bit or 16-bit A pulse wave of given intervals and given duty ratios can be output. Pulse interval: f_{sys} , $f_{sys}/2^1$, $f_{sys}/2^2$, $f_{sys}/2^3$, $f_{sys}/2^4$ (f_{sys} = system clock frequency) 128μs (f_{osc} = 4MHz : oscillation clock frequency)		
16-bit Reload timer		Number of channels: 2 Operation clock frequency: $f_{sys}/2^1$, $f_{sys}/2^3$, $f_{sys}/2^5$ (f_{sys} = System clock frequency) Supports External Event Count function		
16-bit I/O timer	16-bit Output compares	Number of channels: 4 Pin input factor: A match signal of compare register		
	Input captures	Number of channels: 4 Rewriting a register value upon a pin input (rising, falling, or both edges)		

(Continued)

MB90595/595G Series

(Continued)

Features	MB90598	MB90F598/F598G	MB90V595/V595G
CAN Interface	Number of channels: 1 Conforms to CAN Specification Version 2.0 Part A and B Automatic re-transmission in case of error Automatic transmission responding to Remote Frame Prioritized 16 message buffers for data and ID's Supports multiple messages Flexible configuration of acceptance filtering: Full bit compare / Full bit mask / Two partial bit masks Supports up to 1Mbps CAN bit timing setting: MB90xxx:TSEG2 ≥ RSJW+2TQ MB90xxxG:TSEG2 ≥ RSJW		
Stepping motor controller (4 channels)	Four high current outputs for each channel Synchronized two 8-bit PWM's for each channel		
External interrupt circuit	Number of inputs: 8 Started by a rising edge, a falling edge, an "H" level input, or an "L" level input.		
Serial IO	Clock synchronized transmission (31.25 K/62.5 K/125 K/500 K/1 Mbps at system clock frequency of 16 MHz) LSB first/MSB first		
Watchdog timer	Reset generation interval: 3.58 ms, 14.33 ms, 57.23 ms, 458.75 ms (at oscillation of 4 MHz, minimum value)		
Flash Memory	Supports automatic programming, Embedded Algorithm™ and Write/Erase/Erase-Suspend/Resume commands A flag indicating completion of the algorithm Hard-wired reset vector available in order to point to a fixed boot sector in Flash Memory Boot block configuration Erase can be performed on each block Block protection with external programming voltage Flash Writer from Minato Electronics Inc.		
Low-power consumption (stand-by) mode	Sleep/stop/CPU intermittent operation/clock timer/hardware stand-by		
Process	CMOS		
Power supply voltage for operation*2	+5 V±10 %		
Package	QFP-100		PGA-256

*1: It is setting of DIP switch S2 when Emulation pod (MB2145-507) is used.

Please refer to the MB2145-507 hardware manual (2.7 Emulator-specific Power Pin) about details.

*2: Varies with conditions such as the operating frequency. (See section "■ Electrical Characteristics.")

MB90595/595G Series

PIN ASSIGNMENT

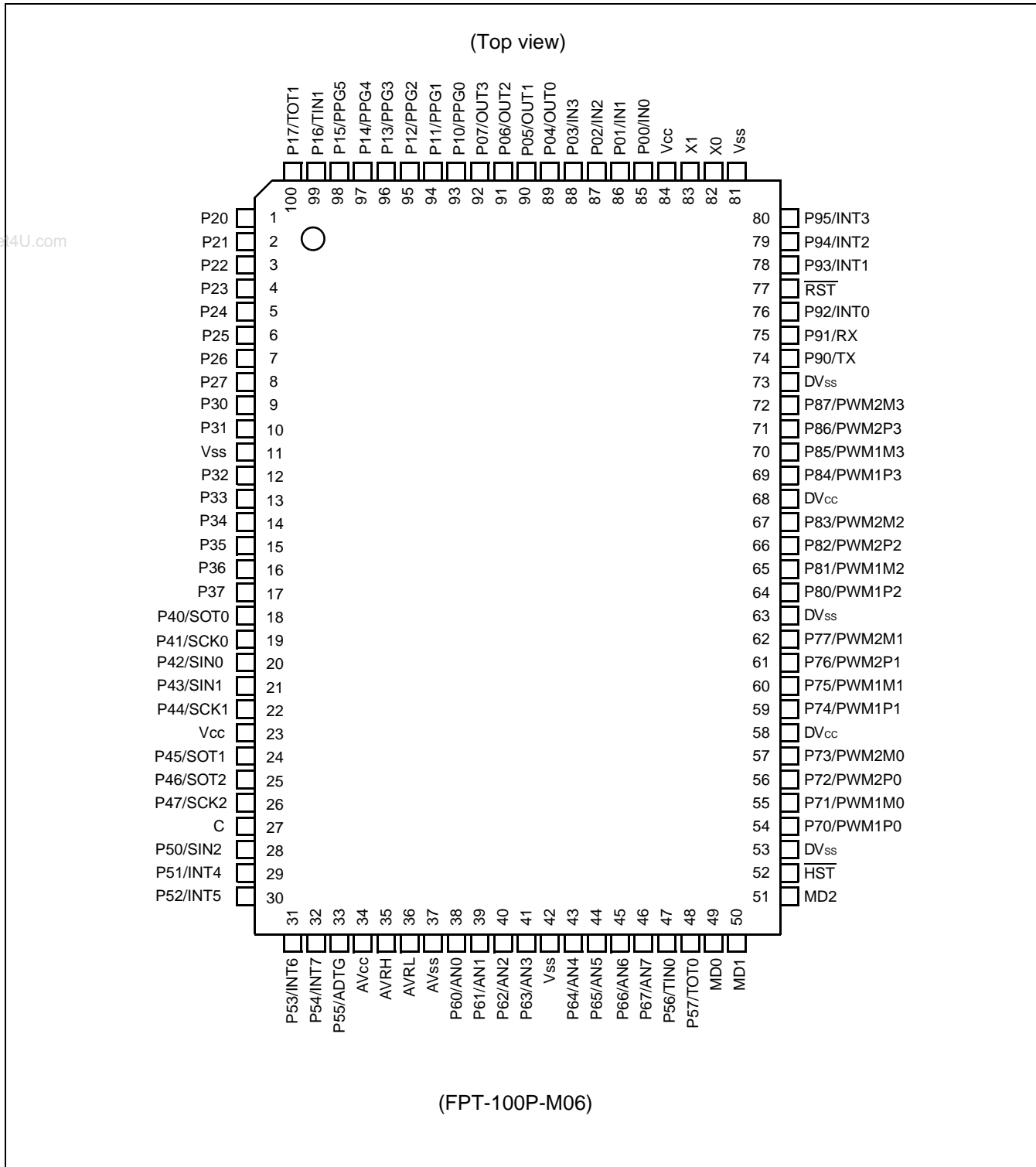

MB90595/595G Series

■ PIN DESCRIPTION

Pin no.	Pin name	Circuit type	Function
82	X0	A	Oscillator pin
83	X1		
77	$\overline{\text{RST}}$	B	Reset input
52	$\overline{\text{HST}}$	C	Hardware standby input
85 to 88	P00 to P03	G	General purpose IO
	IN0 to IN3		Inputs for the Input Captures
89 to 92	P04 to P07	G	General purpose IO
	OUT0 to OUT3		Outputs for the Output Compares.
93 to 98	P10 to P15	D	General purpose IO
	PPG0 to PPG5		Outputs for the Programmable Pulse Generators
99	P16	D	General purpose IO
	TIN1		TIN input for the 16-bit Reload Timer 1
100	P17	D	General purpose IO
	TOT1		TOT output for the 16-bit Reload Timer 1
1 to 8	P20 to P27	G	General purpose IO
9 to 10	P30 to P31	G	General purpose IO
12 to 16	P32 to P36	G	General purpose IO
17	P37	D	General purpose IO
18	P40	G	General purpose IO
	SOT0		SOT output for UART 0
19	P41	G	General purpose IO
	SCK0		SCK input/output for UART 0
20	P42	G	General purpose IO
	SIN0		SIN input for UART 0
21	P43	G	General purpose IO
	SIN1		SIN input for UART 1
22	P44	G	General purpose IO
	SCK1		SCK input/output for UART 1
24	P45	G	General purpose IO
	SOT1		SOT output for UART 1
25	P46	G	General purpose IO
	SOT2		SOT output for the Serial IO
26	P47	G	General purpose IO
	SCK2		SCK input/output for the Serial IO

(Continued)

MB90595/595G Series

Pin no.	Pin name	Circuit type	Function
28	P50	D	General purpose IO
	SIN2		SIN Input for the Serial IO
29 to 32	P51 to P54	D	General purpose IO
	INT4 to INT7		External interrupt input for INT4 to INT7
33	P55	D	General purpose IO
	ADTG		Input for the external trigger of the A/D Converter
38 to 41	P60 to P63	E	General purpose IO
	AN0 to AN3		Inputs for the A/D Converter
43 to 46	P64 to P67	E	General purpose IO
	AN4 to AN7		Inputs for the A/D Converter
47	P56	D	General purpose IO
	TIN0		TIN input for the 16-bit Reload Timer 0
48	P57	D	General purpose IO
	TOT0		TOT output for the 16-bit Reload Timer 0
54 to 57	P70 to P73	F	General purpose IO
	PWM1P0 PWM1M0 PWM2P0 PWM2M0		Output for Stepper Motor Controller channel 0
59 to 62	P74 to P77	F	General purpose IO
	PWM1P1 PWM1M1 PWM2P1 PWM2M1		Output for Stepper Motor Controller channel 1
64 to 67	P80 to P83	F	General purpose IO
	PWM1P2 PWM1M2 PWM2P2 PWM2M2		Output for Stepper Motor Controller channel 2
69 to 72	P84 to P87	F	General purpose IO
	PWM1P3 PWM1M3 PWM2P3 PWM2M3		Output for Stepper Motor Controller channel 3
74	P90	D	General purpose IO
	TX		TX output for CAN Interface
75	P91	D	General purpose IO
	RX		RX input for CAN Interface

(Continued)

MB90595/595G Series

(Continued)

Pin no.	Pin name	Circuit type	Function
76	P92	D	General purpose IO
	INT0		External interrupt input for INT0
78 to 80	P93 to P95	D	General purpose IO
	INT1 to INT3		External interrupt input for INT1 to INT3
58, 68	DV _{CC}	—	Dedicated power supply pins for the high current output buffers (Pin No. 54 to 72)
53, 63, 73	DV _{SS}	—	Dedicated ground pins for the high current output buffers (Pin No. 54 to 72)
34	AV _{CC}	Power supply	Dedicated power supply pin for the A/D Converter
37	AV _{SS}	Power supply	Dedicated ground pin for the A/D Converter
35	AVRH	Power supply	Upper reference voltage input for the A/D Converter
36	AVRL	Power supply	Lower reference voltage input for the A/D Converter
49, 50	MD0 MD1	C	Operating mode selection input pins. These pins should be connected to V _{CC} or V _{SS} .
51	MD2	H	Operating mode selection input pin. This pin should be connected to V _{CC} or V _{SS} .
27	C	—	External capacitor pin. A capacitor of 0.1μF should be connected to this pin and V _{SS} .
23, 84	V _{CC}	Power supply	Power supply pins (5.0 V).
11, 42, 81	V _{SS}	Power supply	Ground pins (0.0 V).

MB90595/595G Series

I/O CIRCUIT TYPE

Circuit Type	Circuit	Remarks
A		<ul style="list-style-type: none"> Oscillation feedback resistor: 1 MΩ approx.
B		<ul style="list-style-type: none"> Hysteresis input with pull-up Resistor: 50 kΩ approx.
C		<ul style="list-style-type: none"> Hysteresis input
D		<ul style="list-style-type: none"> CMOS output CMOS Hysteresis input
E		<ul style="list-style-type: none"> CMOS output CMOS Hysteresis input Analog input

(Continued)

MB90595/595G Series

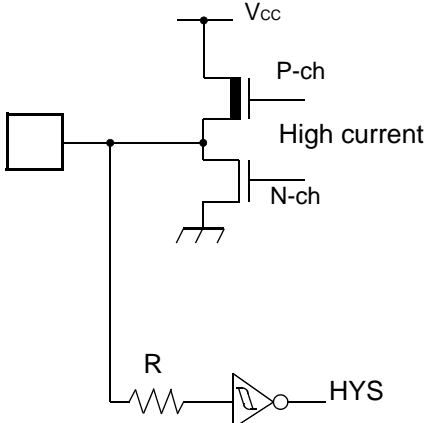
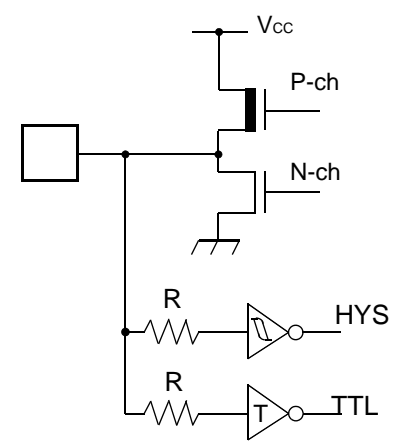
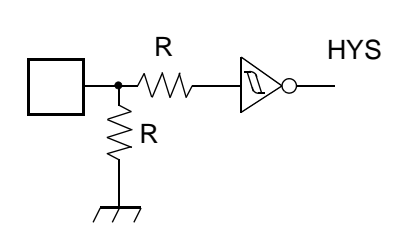
Circuit Type	Circuit	Remarks
F		<ul style="list-style-type: none"> • CMOS high current output • CMOS Hysteresis input
G		<ul style="list-style-type: none"> • CMOS output • CMOS Hysteresis input • TTL input (MB90F598/F598G, only in Flash mode)
H		<ul style="list-style-type: none"> • Hysteresis input • Pull-down Resistor: 50 Ω approx. (except MB90F598/F598G)

MB90595/595G Series

■ HANDLING DEVICES

(1) Make Sure that the Voltage not Exceed the Maximum Rating (to Avoid a Latch-up).

In CMOS ICs, a latch-up phenomenon is caused when an voltage exceeding V_{CC} or an voltage below V_{SS} is applied to input or output pins or a voltage exceeding the rating is applied across V_{CC} and V_{SS} .

When a latch-up is caused, the power supply current may be dramatically increased causing resultant thermal break-down of devices. To avoid the latch-up, make sure that the voltage not exceed the maximum rating.

In turning on/turning off the analog power supply, make sure the analog power voltage (AV_{CC} , $AVRH$, DV_{CC}) and analog input voltages not exceed the digital voltage (V_{CC}).

(2) Treatment of Unused Pins

Unused input pins left open may cause abnormal operation, or latch-up leading to permanent damage. Unused input pins should be pulled up or pulled down through at least 2 k Ω resistance.

Unused input/output pins may be left open in output state, but if such pins are in input state they should be handled in the same way as input pins.

(3) Using external clock

In using the external clock, drive X0 pin only and leave X1 pin unconnected.

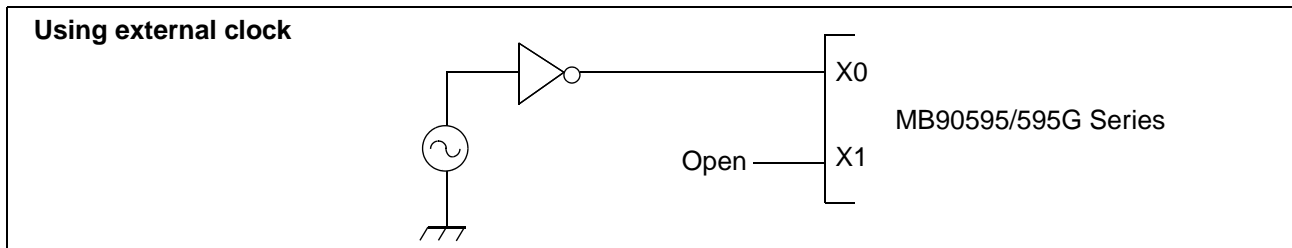

(4) Power supply pins (V_{CC}/V_{SS})

In products with multiple V_{CC} or V_{SS} pins, pins with the same potential are internally connected in the device to avoid abnormal operations including latch-up. However, you must connect the pins to an external power and a ground line to lower the electro-magnetic emission level, to prevent abnormal operation of strobe signals caused by the rise in the ground level, and to conform to the total current rating (See the figure below.)

Make sure to connect V_{CC} and V_{SS} pins via lowest impedance to power lines.

It is recommended to provide a bypass capacitor of around 0.1 μF between V_{CC} and V_{SS} pins near the device.

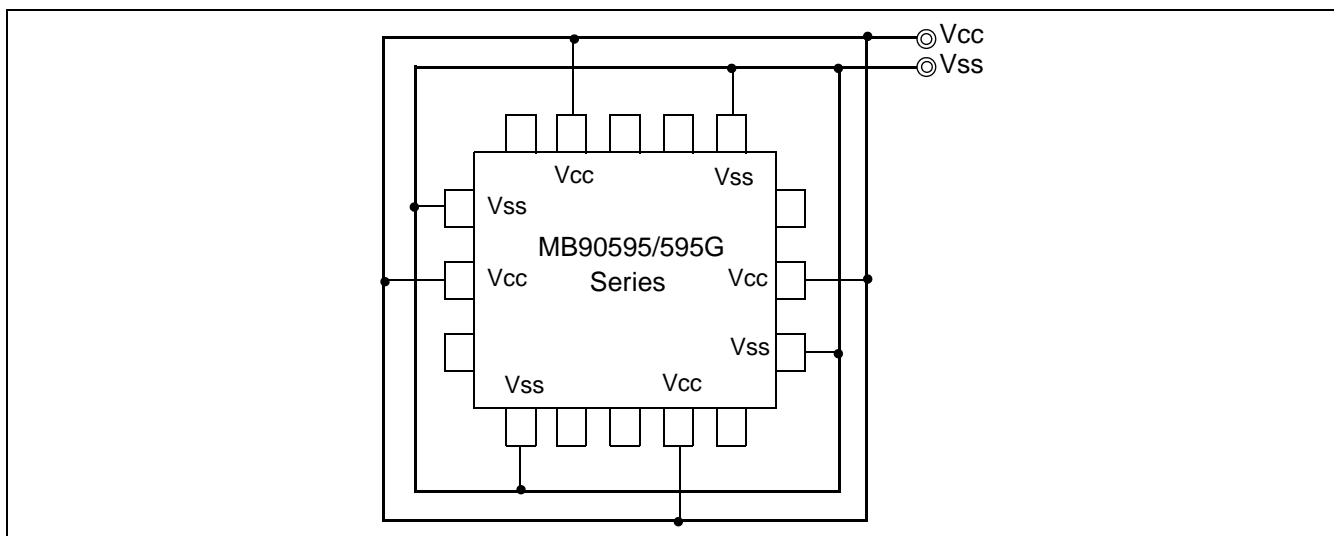

(5) Pull-up/down resistors

The MB90595 Series does not support internal pull-up/down resistors. Use external components where needed.

(6) Crystal Oscillator Circuit

Noises around X0 or X1 pins may cause abnormal operations. Make sure to provide bypass capacitors via shortest distance from X0, X1 pins, crystal oscillator (or ceramic resonator) and ground lines, and make sure that lines of oscillation circuit not cross the lines of other circuits.

A printed circuit board artwork surrounding the X0 and X1 pins with ground area for stabilizing the operation is highly recommended.

(7) Turning-on Sequence of Power Supply to A/D Converter and Analog Inputs

Make sure to turn on the A/D converter power supply (AV_{CC} , AV_{RH} , AV_{RL}) and analog inputs (AN_0 to AN_7) after turning-on the digital power supply (V_{CC}).

Turn-off the digital power after turning off the A/D converter supply and analog inputs. In this case, make sure that the voltage does not exceed AV_{RH} or AV_{CC} (turning on/off the analog and digital power supplies simultaneously is acceptable).

(8) Connection of Unused Pins of A/D Converter

Connect unused pins of A/D converter to $AV_{CC} = V_{CC}$, $AV_{SS} = AV_{RH} = DV_{CC} = V_{SS}$.

(9) N.C. Pin

The N.C. (internally connected) pin must be opened for use.

(10) Notes on Energization

To prevent the internal regulator circuit from malfunctioning, set the voltage rise time during energization at 50 μ s or more (0.2 V to 2.7 V).

(11) Indeterminate outputs from ports 0 and 1

During oscillation setting time of step-down circuit (during a power-on reset) after the power is turned on, the outputs from ports 0 and 1 become following state.

- If \overline{RST} pin is "H", the outputs become indeterminate.
- If \overline{RST} pin is "L", the outputs become high-impedance.

Pay attention to the port output timing shown as follow.

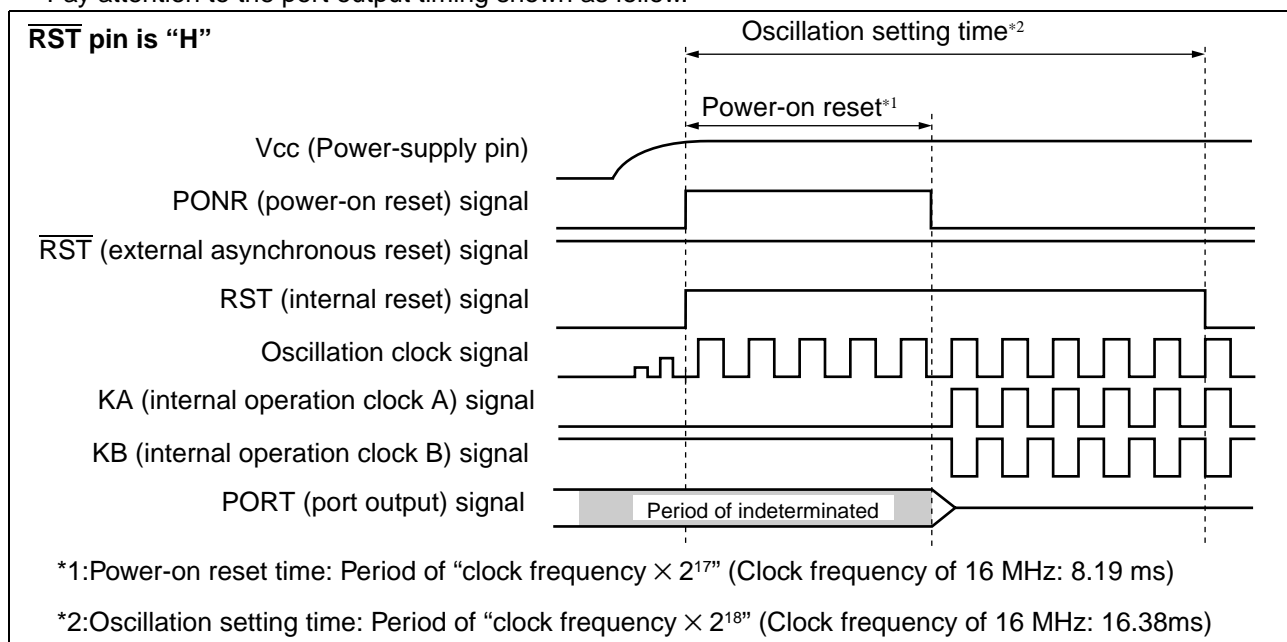

MB90595/595G Series

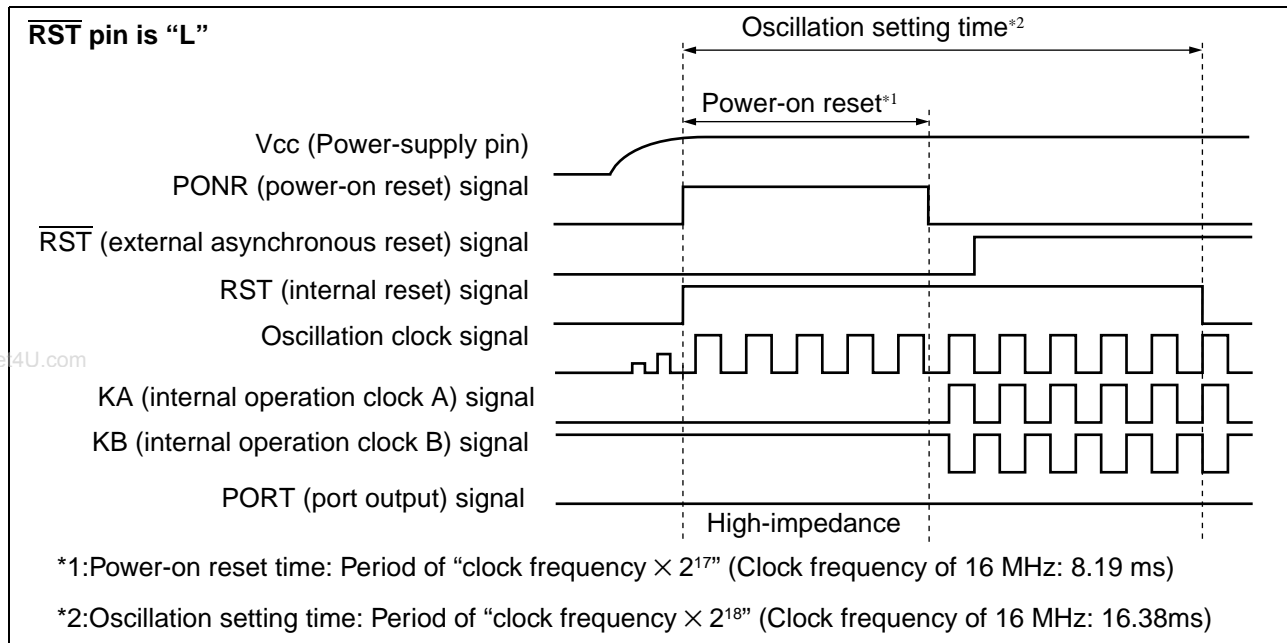

(12) Initialization

The device contains internal registers which are initialized only by a power-on reset. To initialize these registers, please turn on the power again.

(13) Directions of "DIV A, Ri" and "DIVW A, RWi" instructions

In the signed multiplication and division instructions ("DIV A, Ri" and "DIVW A, RWi"), the value of the corresponding bank register (DTB, ADB, USB, SSB) is set in "00H".

If the values of the corresponding bank register (DTB, ADB, USB, SSB) are set to other than "00H", the remainder by the execution result of the instruction is not stored in the register of the instruction operand.

(14) Using REALOS

The use of EI²OS is not possible with the REALOS real time operating system.

■ BLOCK DIAGRAM

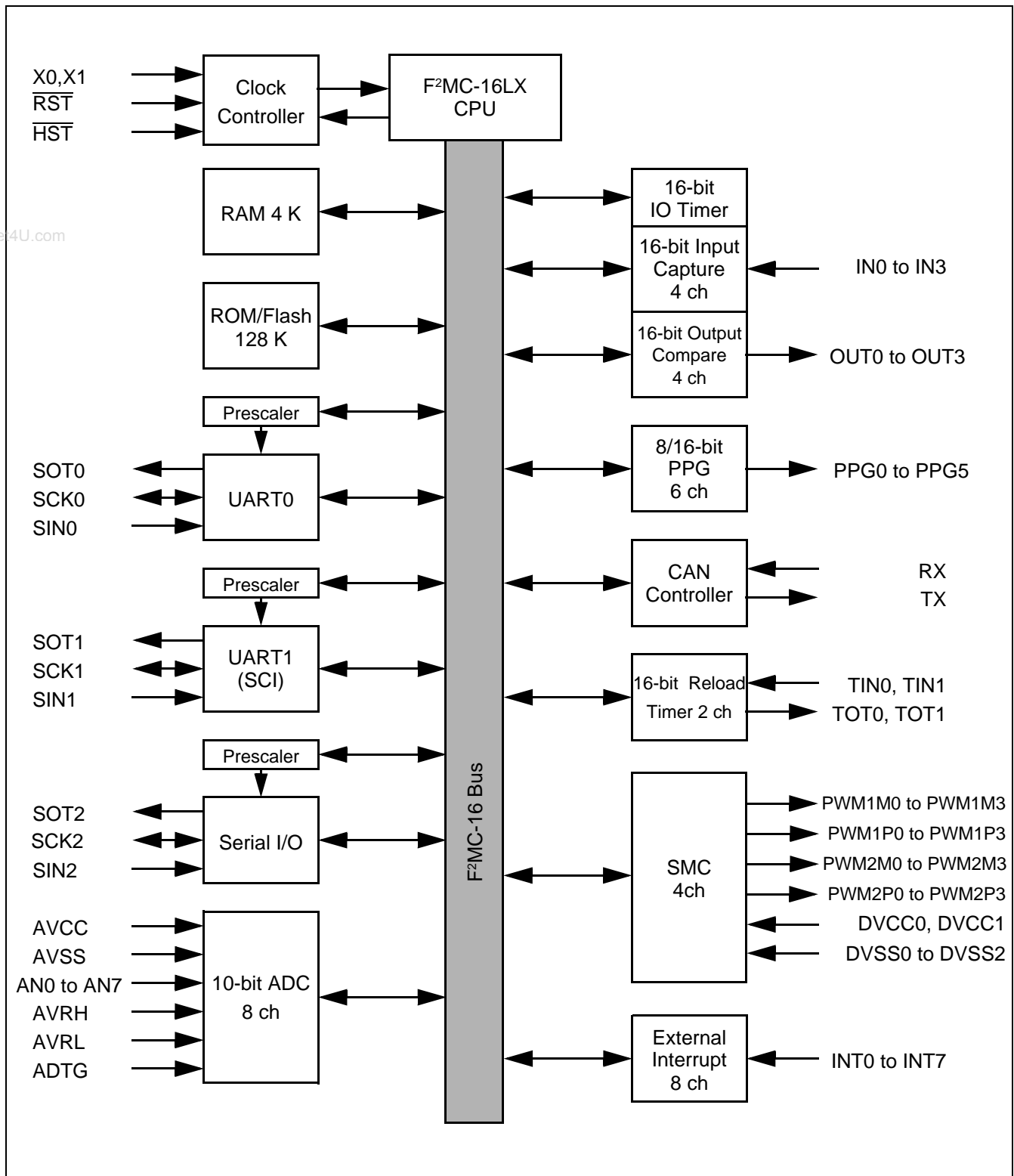

MB90595/595G Series

MEMORY SPACE

The memory space of the MB90595 Series is shown below

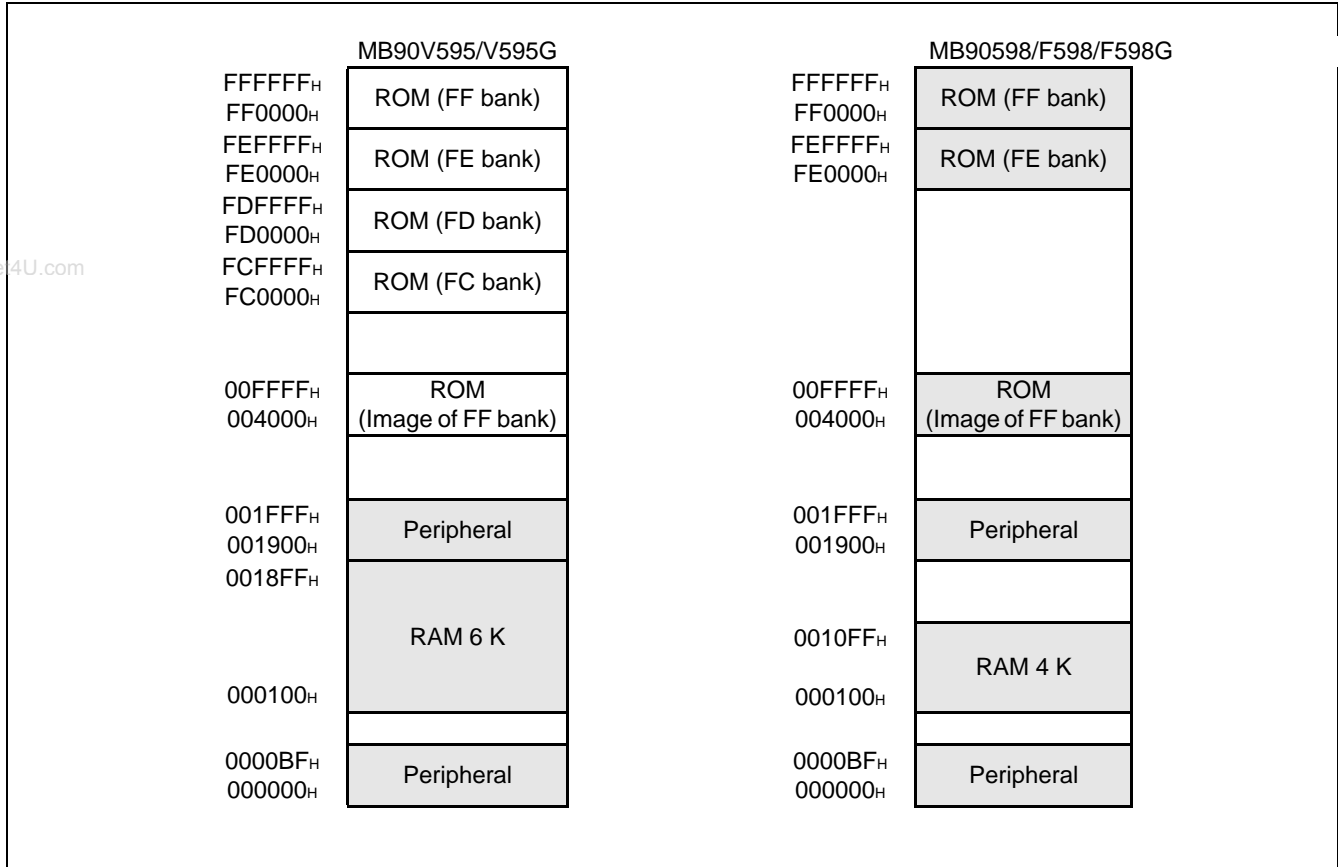

Memory space map

Note: The ROM data of bank FF is reflected in the upper address of bank 00, realizing effective use of the C compiler small model. The lower 16-bit of bank FF and the lower 16-bit of bank 00 are assigned to the same address, enabling reference of the table on the ROM without stating "far".

For example, if an attempt has been made to access 00C000_H, the contents of the ROM at FFC000_H are accessed. Since the ROM area of the FF bank exceeds 48 Kbytes, the whole area cannot be reflected in the image for the 00 bank. The ROM data at FF4000_H to FFFFFFF_H looks, therefore, as if it were the image for 004000_H to 00FFFF_H. Thus, it is recommended that the ROM data table be stored in the area of FF4000_H to FFFFFFF_H.

MB90595/595G Series

■ I/O MAP

Address	Register	Abbreviation	Access	Peripheral	Initial value
00H	Port 0 Data Register	PDR0	R/W	Port 0	XXXXXXXX _B
01H	Port 1 Data Register	PDR1	R/W	Port 1	XXXXXXXX _B
02H	Port 2 Data Register	PDR2	R/W	Port 2	XXXXXXXX _B
03H	Port 3 Data Register	PDR3	R/W	Port 3	XXXXXXXX _B
04H	Port 4 Data Register	PDR4	R/W	Port 4	XXXXXXXX _B
05H	Port 5 Data Register	PDR5	R/W	Port 5	XXXXXXXX _B
06H	Port 6 Data Register	PDR6	R/W	Port 6	XXXXXXXX _B
07H	Port 7 Data Register	PDR7	R/W	Port 7	XXXXXXXX _B
08H	Port 8 Data Register	PDR8	R/W	Port 8	XXXXXXXX _B
09H	Port 9 Data Register	PDR9	R/W	Port 9	__ XXXXXX _B
0AH to 0FH	Reserved				
10H	Port 0 Direction Register	DDR0	R/W	Port 0	0 0 0 0 0 0 0 0 _B
11H	Port 1 Direction Register	DDR1	R/W	Port 1	0 0 0 0 0 0 0 0 _B
12H	Port 2 Direction Register	DDR2	R/W	Port 2	0 0 0 0 0 0 0 0 _B
13H	Port 3 Direction Register	DDR3	R/W	Port 3	0 0 0 0 0 0 0 0 _B
14H	Port 4 Direction Register	DDR4	R/W	Port 4	0 0 0 0 0 0 0 0 _B
15H	Port 5 Direction Register	DDR5	R/W	Port 5	0 0 0 0 0 0 0 0 _B
16H	Port 6 Direction Register	DDR6	R/W	Port 6	0 0 0 0 0 0 0 0 _B
17H	Port 7 Direction Register	DDR7	R/W	Port 7	0 0 0 0 0 0 0 0 _B
18H	Port 8 Direction Register	DDR8	R/W	Port 8	0 0 0 0 0 0 0 0 _B
19H	Port 9 Direction Register	DDR9	R/W	Port 9	__ 0 0 0 0 0 0 _B
1AH	Reserved				
1BH	Analog Input Enable Register	ADER	R/W	Port 6, A/D	1 1 1 1 1 1 1 1 _B
1CH to 1FH	Reserved				
20H	Serial Mode Control Register 0	UMC0	R/W	UART0	0 0 0 0 0 1 0 0 _B
21H	Serial status Register 0	USR0	R/W		0 0 0 1 0 0 0 0 _B
22H	Serial Input/Output Data Register 0	UIDR0/ UODR0	R/W		XXXXXXXX _B
23H	Rate and Data Register 0	URD0	R/W		0 0 0 0 0 0 0 X _B
24H	Serial Mode Register 1	SMR1	R/W	UART1	0 0 0 0 0 0 0 0 _B
25H	Serial Control Register 1	SCR1	R/W		0 0 0 0 0 1 0 0 _B
26H	Serial Input/Output Data Register 1	SIDR1/ SODR1	R/W		XXXXXXXX _B
27H	Serial Status Register 1	SSR1	R/W		0 0 0 0 1 _ 0 0 _B
28H	UART1 Prescaler Control Register	U1CDR	R/W		0 _ _ _ 1 1 1 1 _B

(Continued)

MB90595/595G Series

Address	Register	Abbreviation	Access	Peripheral	Initial value
29H to 2AH	Reserved				
2BH	Serial IO Prescaler	SCDCR	R/W	Serial IO	0 ___ 1 1 1 1 _B
2CH	Serial Mode Control Register (low-order)	SMCS	R/W		___ 0 0 0 0 _B
2DH	Serial Mode Control Register (high-order)	SMCS	R/W		0 0 0 0 0 1 0 _B
2EH	Serial Data Register	SDR	R/W		XXXXXXXX _B
2FH	Edge Selector	SES	R/W		___ 0 _B
30H	External Interrupt Enable Register	ENIR	R/W	External Interrupt	0 0 0 0 0 0 0 0 _B
31H	External Interrupt Request Register	EIRR	R/W		XXXXXXXX _B
32H	External Interrupt Level Register	ELVR	R/W		0 0 0 0 0 0 0 0 _B
33H	External Interrupt Level Register	ELVR	R/W		0 0 0 0 0 0 0 0 _B
34H	A/D Control Status Register 0	ADCS0	R/W	A/D Converter	0 0 0 0 0 0 0 0 _B
35H	A/D Control Status Register 1	ADCS1	R/W		0 0 0 0 0 0 0 0 _B
36H	A/D Data Register 0	ADCR0	R		XXXXXXXX _B
37H	A/D Data Register 1	ADCR1	R/W		0 0 0 0 1 _ XX _B
38H	PPG0 Operation Mode Control Register	PPGC0	R/W	16-bit Program- mable Pulse Generator 0/1	0 _ 0 0 0 _ _ 1 _B
39H	PPG1 Operation Mode Control Register	PPGC1	R/W		0 _ 0 0 0 0 0 1 _B
3AH	PPG0, 1 Output Pin Control Register	PPG01	R/W		0 0 0 0 0 0 _ _ _B
3BH	Reserved				
3CH	PPG2 Operation Mode Control Register	PPGC2	R/W	16-bit Program- mable Pulse Generator 2/3	0 _ 0 0 0 _ _ 1 _B
3DH	PPG3 Operation Mode Control Register	PPGC3	R/W		0 _ 0 0 0 0 0 1 _B
3EH	PPG2, 3 Output Pin Control Register	PPG23	R/W		0 0 0 0 0 0 _ _ _B
3FH	Reserved				
40H	PPG4 Operation Mode Control Register	PPGC4	R/W	16-bit Program- mable Pulse Generator 4/5	0 _ 0 0 0 _ _ 1 _B
41H	PPG5 Operation Mode Control Register	PPGC5	R/W		0 _ 0 0 0 0 0 1 _B
42H	PPG4, 5 Output Pin Control Register	PPG45	R/W		0 0 0 0 0 0 _ _ _B
43H	Reserved				
44H	PPG6 Operation Mode Control Register	PPGC6	R/W	16-bit Program- mable Pulse Generator 6/7	0 _ 0 0 0 _ _ 1 _B
45H	PPG7 Operation Mode Control Register	PPGC7	R/W		0 _ 0 0 0 0 0 1 _B
46H	PPG6, 7 Output Pin Control Register	PPG67	R/W		0 0 0 0 0 0 _ _ _B
47H	Reserved				
48H	PPG8 Operation Mode Control Register	PPGC8	R/W	16-bit Program- mable Pulse Generator 8/9	0 _ 0 0 0 _ _ 1 _B
49H	PPG9 Operation Mode Control Register	PPGC9	R/W		0 _ 0 0 0 0 0 1 _B
4AH	PPG8, 9 Output Pin Control Register	PPG89	R/W		0 0 0 0 0 0 _ _ _B
4BH	Reserved				

(Continued)

MB90595/595G Series

Address	Register	Abbreviation	Access	Peripheral	Initial value
4C _H	PPGA Operation Mode Control Register	PPGCA	R/W	16-bit Programmable Pulse Generator A/B	0_000__1 _B
4D _H	PPGB Operation Mode Control Register	PPGCB	R/W		0_000001 _B
4E _H	PPGA, B Output Pin Control Register	PPGAB	R/W		000000__ _B
4F _H	Reserved				
50 _H	Timer Control Status Register 0	TMCSR0	R/W	16-bit Reload Timer 0	00000000 _B
51 _H	Timer Control Status Register 0	TMCSR0	R/W		__ __ __ 0000 _B
52 _H	Timer 0/Reload Register 0	TMR0/ TMRLR0	R/W		XXXXXXXX _B
53 _H	Timer 0/Reload Register 0	TMR0/ TMRLR0	R/W		XXXXXXXX _B
54 _H	Timer Control Status Register 1	TMCSR1	R/W	16-bit Reload Timer 1	00000000 _B
55 _H	Timer Control Status Register 1	TMCSR1	R/W		__ __ __ 0000 _B
56 _H	Timer Register 1/Reload Register 1	TMR1/ TMRLR1	R/W		XXXXXXXX _B
57 _H	Timer Register 1/Reload Register 1	TMR1/ TMRLR1	R/W		XXXXXXXX _B
58 _H	Output Compare Control Status Register 0	OCS0	R/W	Output Compare 0/1	0000__00 _B
59 _H	Output Compare Control Status Register 1	OCS1	R/W		__ __ 00000 _B
5A _H	Output Compare Control Status Register 2	OCS2	R/W	Output Compare 2/3	0000__00 _B
5B _H	Output Compare Control Status Register 3	OCS3	R/W		__ __ 00000 _B
5C _H	Input Capture Control Status Register 0/1	ICS01	R/W	Input Capture 0/1	00000000 _B
5D _H	Input Capture Control Status Register 2/3	ICS23	R/W	Input Capture 2/3	00000000 _B
5E _H	PWM Control Register 0	PWC0	R/W	Stepping Motor Controller 0	00000__0 _B
5F _H	Reserved				
60 _H	PWM Control Register 1	PWC1	R/W	Stepping Motor Controller 1	00000__0 _B
61 _H	Reserved				
62 _H	PWM Control Register 2	PWC2	R/W	Stepping Motor Controller 2	00000__0 _B
63 _H	Reserved				
64 _H	PWM Control Register 3	PWC3	R/W	Stepping Motor Controller 3	00000__0 _B
65 _H	Reserved				
66 _H	Timer Data Register (low-order)	TCDT	R/W	IO Timer	00000000 _B
67 _H	Timer Data Register (high-order)	TCDT	R/W		00000000 _B
68 _H	Timer Control Status Register	TCCS	R/W		00000000 _B
69 _H to 6E _H	Reserved				

(Continued)

MB90595/595G Series

Address	Register	Abbreviation	Access	Peripheral	Initial value
6FH	ROM Mirror Function Selection Register	ROMM	R/W	ROM Mirror	_____ 1 _B
70H	PWM1 Compare Register 0	PWC10	R/W	Stepping Motor Controller 0	XXXXXXXX _B
71H	PWM2 Compare Register 0	PWC20	R/W		XXXXXXXX _B
72H	PWM1 Select Register 0	PWS10	R/W		_ _ 0 0 0 0 0 0 _B
73H	PWM2 Select Register 0	PWS20	R/W		_ 0 0 0 0 0 0 _B
74H	PWM1 Compare Register 1	PWC11	R/W	Stepping Motor Controller 1	XXXXXXXX _B
75H	PWM2 Compare Register 1	PWC21	R/W		XXXXXXXX _B
76H	PWM1 Select Register 1	PWS11	R/W		_ _ 0 0 0 0 0 0 _B
77H	PWM2 Select Register 1	PWS21	R/W	_ 0 0 0 0 0 0 _B	
78H	PWM1 Compare Register 2	PWC12	R/W	Stepping Motor Controller 2	XXXXXXXX _B
79H	PWM2 Compare Register 2	PWC22	R/W		XXXXXXXX _B
7AH	PWM1 Select Register 2	PWS12	R/W		_ _ 0 0 0 0 0 0 _B
7BH	PWM2 Select Register 2	PWS22	R/W		_ 0 0 0 0 0 0 _B
7CH	PWM1 Compare Register 3	PWC13	R/W	Stepping Motor Controller 3	XXXXXXXX _B
7DH	PWM2 Compare Register 3	PWC23	R/W		XXXXXXXX _B
7EH	PWM1 Select Register 3	PWS13	R/W		_ _ 0 0 0 0 0 0 _B
7FH	PWM2 Select Register 3	PWS23	R/W		_ 0 0 0 0 0 0 _B
80H to 8FH	CAN Controller. Refer to section about CAN Controller				
90H to 9DH	Reserved				
9EH	Program Address Detection Control Status Register	PACSR	R/W	Address Match Detection Function	0 0 0 0 0 0 0 0 _B
9FH	Delayed Interrupt/Request Register	DIRR	R/W	Delayed Interrupt	_____ 0 _B
A0H	Low-Power Mode Control Register	LPMCR	R/W	Low Power Controller	0 0 0 1 1 0 0 0 _B
A1H	Clock Selection Register	CKSCR	R/W	Low Power Controller	1 1 1 1 1 1 0 0 _B
A2H to A7H	Reserved				
A8H	Watchdog Timer Control Register	WDTC	R/W	Watchdog Timer	XXXXX 1 1 1 _B
A9H	Time Base Timer Control Register	TBTC	R/W	Time Base Timer	1 _ _ 0 0 1 0 0 _B
AAH to ADH	Reserved				
AEH	Flash Memory Control Status Register (MB90F598/F598G only. Otherwise reserved)	FMCS	R/W	Flash Memory	0 0 0 X 0 0 0 0 _B
AFH	Reserved				

(Continued)

MB90595/595G Series

Address	Register	Abbreviation	Access	Peripheral	Initial value
B0 _H	Interrupt Control Register 00	ICR00	R/W	Interrupt controller	0 0 0 0 0 1 1 1 _B
B1 _H	Interrupt Control Register 01	ICR01	R/W		0 0 0 0 0 1 1 1 _B
B2 _H	Interrupt Control Register 02	ICR02	R/W		0 0 0 0 0 1 1 1 _B
B3 _H	Interrupt Control Register 03	ICR03	R/W		0 0 0 0 0 1 1 1 _B
B4 _H	Interrupt Control Register 04	ICR04	R/W	Interrupt controller	0 0 0 0 0 1 1 1 _B
B5 _H	Interrupt Control Register 05	ICR05	R/W		0 0 0 0 0 1 1 1 _B
B6 _H	Interrupt Control Register 06	ICR06	R/W		0 0 0 0 0 1 1 1 _B
B7 _H	Interrupt Control Register 07	ICR07	R/W		0 0 0 0 0 1 1 1 _B
B8 _H	Interrupt Control Register 08	ICR08	R/W		0 0 0 0 0 1 1 1 _B
B9 _H	Interrupt Control Register 09	ICR09	R/W		0 0 0 0 0 1 1 1 _B
BA _H	Interrupt Control Register 10	ICR10	R/W		0 0 0 0 0 1 1 1 _B
BB _H	Interrupt Control Register 11	ICR11	R/W		0 0 0 0 0 1 1 1 _B
BC _H	Interrupt Control Register 12	ICR12	R/W		0 0 0 0 0 1 1 1 _B
BD _H	Interrupt Control Register 13	ICR13	R/W		0 0 0 0 0 1 1 1 _B
BE _H	Interrupt Control Register 14	ICR14	R/W		0 0 0 0 0 1 1 1 _B
BF _H	Interrupt Control Register 15	ICR15	R/W		0 0 0 0 0 1 1 1 _B
C0 _H to FF _H	Reserved				
1900 _H	Reload Register L	PRL0	R/W	16-bit Programmable Pulse Generator 0/1	XXXXXXXX _B
1901 _H	Reload Register H	PRLH0	R/W		XXXXXXXX _B
1902 _H	Reload Register L	PRL1	R/W		XXXXXXXX _B
1903 _H	Reload Register H	PRLH1	R/W		XXXXXXXX _B
1904 _H	Reload Register L	PRL2	R/W	16-bit Programmable Pulse Generator 2/3	XXXXXXXX _B
1905 _H	Reload Register H	PRLH2	R/W		XXXXXXXX _B
1906 _H	Reload Register L	PRL3	R/W		XXXXXXXX _B
1907 _H	Reload Register H	PRLH3	R/W		XXXXXXXX _B
1908 _H	Reload Register L	PRL4	R/W	16-bit Programmable Pulse Generator 4/5	XXXXXXXX _B
1909 _H	Reload Register H	PRLH4	R/W		XXXXXXXX _B
190A _H	Reload Register L	PRL5	R/W		XXXXXXXX _B
190B _H	Reload Register H	PRLH5	R/W		XXXXXXXX _B
190C _H	Reload Register L	PRL6	R/W	16-bit Programmable Pulse Generator 6/7	XXXXXXXX _B
190D _H	Reload Register H	PRLH6	R/W		XXXXXXXX _B
190E _H	Reload Register L	PRL7	R/W		XXXXXXXX _B
190F _H	Reload Register H	PRLH7	R/W		XXXXXXXX _B

(Continued)

MB90595/595G Series

(Continued)

Address	Register	Abbreviation	Access	Peripheral	Initial value
1910 _H	Reload Register L	PRL8	R/W	16-bit Programmable Pulse Generator 8/9	XXXXXXXX _B
1911 _H	Reload Register H	PRLH8	R/W		XXXXXXXX _B
1912 _H	Reload Register L	PRL9	R/W		XXXXXXXX _B
1913 _H	Reload Register H	PRLH9	R/W		XXXXXXXX _B
1914 _H	Reload Register L	PRLLA	R/W	16-bit Programmable Pulse Generator A/B	XXXXXXXX _B
1915 _H	Reload Register H	PRLHA	R/W		XXXXXXXX _B
1916 _H	Reload Register L	PRLLB	R/W	16-bit Programmable Pulse Generator A/B	XXXXXXXX _B
1917 _H	Reload Register H	PRLHB	R/W		XXXXXXXX _B
1918 _H to 191F _H	Reserved				
1920 _H	Input Capture Register 0 (low-order)	IPCP0	R	Input Capture 0/1	XXXXXXXX _B
1921 _H	Input Capture Register 0 (high-order)	IPCP0	R		XXXXXXXX _B
1922 _H	Input Capture Register 1 (low-order)	IPCP1	R		XXXXXXXX _B
1923 _H	Input Capture Register 1 (high-order)	IPCP1	R		XXXXXXXX _B
1924 _H	Input Capture Register 2 (low-order)	IPCP2	R	Input Capture 2/3	XXXXXXXX _B
1925 _H	Input Capture Register 2 (high-order)	IPCP2	R		XXXXXXXX _B
1926 _H	Input Capture Register 3 (low-order)	IPCP3	R		XXXXXXXX _B
1927 _H	Input Capture Register 3 (high-order)	IPCP3	R		XXXXXXXX _B
1928 _H	Output Compare Register 0 (low-order)	OCCP0	R/W	Output Compare 0/1	XXXXXXXX _B
1929 _H	Output Compare Register 0 (high-order)	OCCP0	R/W		XXXXXXXX _B
192A _H	Output Compare Register 1 (low-order)	OCCP1	R/W		XXXXXXXX _B
192B _H	Output Compare Register 1 (high-order)	OCCP1	R/W		XXXXXXXX _B

(Continued)

MB90595/595G Series

(Continued)

Address	Register	Abbreviation	Access	Peripheral	Initial value
192C _H	Output Compare Register 2 (low-order)	OCCP2	R/W	Output Compare 2/3	XXXXXXXX _B
192D _H	Output Compare Register 2 (high-order)	OCCP2	R/W		XXXXXXXX _B
192E _H	Output Compare Register 3 (low-order)	OCCP3	R/W		XXXXXXXX _B
192F _H	Output Compare Register 3 (high-order)	OCCP3	R/W		XXXXXXXX _B
1930 _H to 19FF _H	Reserved				
1A00 _H to 1AFF _H	CAN Controller. Refer to section about CAN Controller				
1B00 _H to 1BFF _H	CAN Controller. Refer to section about CAN Controller				
1C00 _H to 1EFF _H	Reserved				
1FF0 _H	Program Address Detection Register 0 (low-order)	PADR0	R/W	Address Match Detection Function	XXXXXXXX _B
1FF1 _H	Program Address Detection Register 0 (middle-order)				XXXXXXXX _B
1FF2 _H	Program Address Detection Register 0 (high-order)				XXXXXXXX _B
1FF3 _H	Program Address Detection Register 1 (low-order)	PADR1	R/W		XXXXXXXX _B
1FF4 _H	Program Address Detection Register 1 (middle-order)				XXXXXXXX _B
1FF5 _H	Program Address Detection Register 1 (high-order)				XXXXXXXX _B
1FF6 _H to 1FFF _H	Reserved				

Note: Initial value of “_” represents unused bit; “X” represents unknown value.

Addresses in the range 0000_H to 00FF_H, which are not listed in the table, are reserved for the primary functions of the MCU. A read access to these reserved addresses results in reading “X”, and any write access should not be performed.

MB90595/595G Series

■ CAN CONTROLLER

The CAN controller has the following features:

- Conforms to CAN Specification Version 2.0 Part A and B
 - Supports transmission/reception in standard frame and extended frame formats
- Supports transmission of data frames by receiving remote frames
- 16 transmitting/receiving message buffers
 - 29-bit ID and 8-byte data
 - Multi-level message buffer configuration
- Provides full-bit comparison, full-bit mask, acceptance register 0/acceptance register 1 for each message buffer as 1D acceptance mask
 - Two acceptance mask registers in either standard frame format or extended frame formats
- Bit rate programmable from 10 Kbit/s to 2 Mbit/s (when input clock is at 16 MHz)

List of Control Registers

Address	Register	Abbreviation	Access	Initial Value
000080 _H	Message buffer valid register	BVALR	R/W	00000000 00000000 _B
000081 _H				
000082 _H	Transmit request register	TREQR	R/W	00000000 00000000 _B
000083 _H				
000084 _H	Transmit cancel register	TCANR	W	00000000 00000000 _B
000085 _H				
000086 _H	Transmit complete register	TCR	R/W	00000000 00000000 _B
000087 _H				
000088 _H	Receive complete register	RCR	R/W	00000000 00000000 _B
000089 _H				
00008A _H	Remote request receiving register	RRTRR	R/W	00000000 00000000 _B
00008B _H				
00008C _H	Receive overrun register	ROVRR	R/W	00000000 00000000 _B
00008D _H				
00008E _H	Receive interrupt enable register	RIER	R/W	00000000 00000000 _B
00008F _H				
001B00 _H	Control status register	CSR	R/W, R	00---000 0----0-1 _B
001B01 _H				
001B02 _H	Last event indicator register	LEIR	R/W	----- 000-0000 _B
001B03 _H				
001B04 _H	Receive/transmit error counter	RTEC	R	00000000 00000000 _B
001B05 _H				
001B06 _H	Bit timing register	BTR	R/W	-11111111 11111111 _B
001B07 _H				

(Continued)

MB90595/595G Series

(Continued)

Address	Register	Abbreviation	Access	Initial Value
001B08H	IDE register	IDER	R/W	XXXXXXXX XXXXXXXXB
001B09H				
001B0AH	Transmit RTR register	TRTRR	R/W	00000000 00000000B
001B0BH				
001B0CH	Remote frame receive waiting register	RFWTR	R/W	XXXXXXXX XXXXXXXXB
001B0DH				
001B0EH	Transmit interrupt enable register	TIER	R/W	00000000 00000000B
001B0FH				
001B10H	Acceptance mask select register	AMSR	R/W	XXXXXXXX XXXXXXXXB
001B11H				XXXXXXXX XXXXXXXXB
001B12H				XXXXXXXX XXXXXXXXB
001B13H				XXXXXXXX XXXXXXXXB
001B14H	Acceptance mask register 0	AMR0	R/W	XXXXXXXX XXXXXXXXB
001B15H				XXXXX--- XXXXXXXXB
001B16H				XXXXX--- XXXXXXXXB
001B17H				XXXXX--- XXXXXXXXB
001B18H	Acceptance mask register 1	AMR1	R/W	XXXXXXXX XXXXXXXXB
001B19H				XXXXX--- XXXXXXXXB
001B1AH				XXXXX--- XXXXXXXXB
001B1BH				XXXXX--- XXXXXXXXB

MB90595/595G Series

List of Message Buffers (ID Registers)

Address	Register	Abbreviation	Access	Initial Value
001A00H to 001A1FH	General-purpose RAM	--	R/W	XXXXXXXX _B to XXXXXXXX _B
001A20H	ID register 0	IDR0	R/W	XXXXXXXX XXXXXXXX _B
001A21H				XXXXX--- XXXXXXXX _B
001A22H				
001A23H				
001A24H	ID register 1	IDR1	R/W	XXXXXXXX XXXXXXXX _B
001A25H				XXXXX--- XXXXXXXX _B
001A26H				
001A27H				
001A28H	ID register 2	IDR2	R/W	XXXXXXXX XXXXXXXX _B
001A29H				XXXXX--- XXXXXXXX _B
001A2AH				
001A2BH				
001A2CH	ID register 3	IDR3	R/W	XXXXXXXX XXXXXXXX _B
001A2DH				XXXXX--- XXXXXXXX _B
001A2EH				
001A2FH				
001A30H	ID register 4	IDR4	R/W	XXXXXXXX XXXXXXXX _B
001A31H				XXXXX--- XXXXXXXX _B
001A32H				
001A33H				
001A34H	ID register 5	IDR5	R/W	XXXXXXXX XXXXXXXX _B
001A35H				XXXXX--- XXXXXXXX _B
001A36H				
001A37H				
001A38H	ID register 6	IDR6	R/W	XXXXXXXX XXXXXXXX _B
001A39H				XXXXX--- XXXXXXXX _B
001A3AH				
001A3BH				
001A3CH	ID register 7	IDR7	R/W	XXXXXXXX XXXXXXXX _B
001A3DH				XXXXX--- XXXXXXXX _B
001A3EH				
001A3FH				

(Continued)

MB90595/595G Series

(Continued)

Address	Register	Abbreviation	Access	Initial Value
001A40 _H	ID register 8	IDR8	R/W	XXXXXXXX XXXXXXXX _B
001A41 _H				XXXXX--- XXXXXXXX _B
001A42 _H				
001A43 _H				
001A44 _H	ID register 9	IDR9	R/W	XXXXXXXX XXXXXXXX _B
001A45 _H				XXXXX--- XXXXXXXX _B
001A46 _H				
001A47 _H				
001A48 _H	ID register 10	IDR10	R/W	XXXXXXXX XXXXXXXX _B
001A49 _H				XXXXX--- XXXXXXXX _B
001A4A _H				
001A4B _H				
001A4C _H	ID register 11	IDR11	R/W	XXXXXXXX XXXXXXXX _B
001A4D _H				XXXXX--- XXXXXXXX _B
001A4E _H				
001A4F _H				
001A50 _H	ID register 12	IDR12	R/W	XXXXXXXX XXXXXXXX _B
001A51 _H				XXXXX--- XXXXXXXX _B
001A52 _H				
001A53 _H				
001A54 _H	ID register 13	IDR13	R/W	XXXXXXXX XXXXXXXX _B
001A55 _H				XXXXX--- XXXXXXXX _B
001A56 _H				
001A57 _H				
001A58 _H	ID register 14	IDR14	R/W	XXXXXXXX XXXXXXXX _B
001A59 _H				XXXXX--- XXXXXXXX _B
001A5A _H				
001A5B _H				
001A5C _H	ID register 15	IDR15	R/W	XXXXXXXX XXXXXXXX _B
001A5D _H				XXXXX--- XXXXXXXX _B
001A5E _H				
001A5F _H				

MB90595/595G Series

List of Message Buffers (DLC Registers and Data Registers)

Address	Register	Abbreviation	Access	Initial Value
001A60 _H	DLC register 0	DLCR0	R/W	----XXXX _B
001A61 _H				
001A62 _H	DLC register 1	DLCR1	R/W	----XXXX _B
001A63 _H				
001A64 _H	DLC register 2	DLCR2	R/W	----XXXX _B
001A65 _H				
001A66 _H	DLC register 3	DLCR3	R/W	----XXXX _B
001A67 _H				
001A68 _H	DLC register 4	DLCR4	R/W	----XXXX _B
001A69 _H				
001A6A _H	DLC register 5	DLCR5	R/W	----XXXX _B
001A6B _H				
001A6C _H	DLC register 6	DLCR6	R/W	----XXXX _B
001A6D _H				
001A6E _H	DLC register 7	DLCR7	R/W	----XXXX _B
001A6F _H				
001A70 _H	DLC register 8	DLCR8	R/W	----XXXX
001A71 _H				
001A72 _H	DLC register 9	DLCR9	R/W	----XXXX _B
001A73 _H				
001A74 _H	DLC register 10	DLCR10	R/W	----XXXX _B
001A75 _H				
001A76 _H	DLC register 11	DLCR11	R/W	----XXXX _B
001A77 _H				
001A78 _H	DLC register 12	DLCR12	R/W	----XXXX _B
001A79 _H				
001A7A _H	DLC register 13	DLCR13	R/W	----XXXX _B
001A7B _H				
001A7C _H	DLC register 14	DLCR14	R/W	----XXXX _B
001A7D _H				
001A7E _H	DLC register 15	DLCR15	R/W	----XXXX _B
001A7F _H				
001A80 _H to 001A87 _H	Data register 0 (8 bytes)	DTR0	R/W	XXXXXXXX _B to XXXXXXXX _B

(Continued)

MB90595/595G Series

(Continued)

Address	Register	Abbreviation	Access	Initial Value
001A88 _H to 001A8F _H	Data register 1 (8 bytes)	DTR1	R/W	XXXXXXXX _B to XXXXXXXX _B
001A90 _H to 001A97 _H	Data register 2 (8 bytes)	DTR2	R/W	XXXXXXXX _B to XXXXXXXX _B
001A98 _H to 001A9F _H	Data register 3 (8 bytes)	DTR3	R/W	XXXXXXXX _B to XXXXXXXX _B
001AA0 _H to 001AA7 _H	Data register 4 (8 bytes)	DTR4	R/W	XXXXXXXX _B to XXXXXXXX _B
001AA8 _H to 001AAF _H	Data register 5 (8 bytes)	DTR5	R/W	XXXXXXXX _B to XXXXXXXX _B
001AB0 _H to 001AB7 _H	Data register 6 (8 bytes)	DTR6	R/W	XXXXXXXX _B to XXXXXXXX _B
001AB8 _H to 001ABF _H	Data register 7 (8 bytes)	DTR7	R/W	XXXXXXXX _B to XXXXXXXX _B
001AC0 _H to 001AC7 _H	Data register 8 (8 bytes)	DTR8	R/W	XXXXXXXX _B to XXXXXXXX _B
001AC8 _H to 001ACF _H	Data register 9 (8 bytes)	DTR9	R/W	XXXXXXXX _B to XXXXXXXX _B
001AD0 _H to 001AD7 _H	Data register 10 (8 bytes)	DTR10	R/W	XXXXXXXX _B to XXXXXXXX _B
001AD8 _H to 001ADF _H	Data register 11 (8 bytes)	DTR11	R/W	XXXXXXXX _B to XXXXXXXX _B
001AE0 _H to 001AE7 _H	Data register 12 (8 bytes)	DTR12	R/W	XXXXXXXX _B to XXXXXXXX _B
001AE8 _H to 001AEF _H	Data register 13 (8 bytes)	DTR13	R/W	XXXXXXXX _B to XXXXXXXX _B
001AF0 _H to 001AF7 _H	Data register 14 (8 bytes)	DTR14	R/W	XXXXXXXX _B to XXXXXXXX _B
001AF8 _H to 001AFF _H	Data register 15 (8 bytes)	DTR15	R/W	XXXXXXXX _B to XXXXXXXX _B

MB90595/595G Series

■ INTERRUPT MAP

Interrupt source	EI ² OS clear	Interrupt vector		Interrupt control register	
		Number	Address	Number	Address
Reset	N/A	# 08	FFFFDC _H	—	—
INT9 instruction	N/A	# 09	FFFFD8 _H	—	—
Exception	N/A	# 10	FFFFD4 _H	—	—
CAN RX	N/A	# 11	FFFFD0 _H	ICR00	0000B0 _H
CAN TX/NS	N/A	# 12	FFFFCC _H		
External Interrupt (INT0/INT1)	*1	# 13	FFFFC8 _H	ICR01	0000B1 _H
Time Base Timer	N/A	# 14	FFFFC4 _H		
16-bit Reload Timer 0	*1	# 15	FFFFC0 _H	ICR02	0000B2 _H
8/10-bit A/D Converter	*1	# 16	FFFFBC _H		
I/O Timer	N/A	# 17	FFFFB8 _H	ICR03	0000B3 _H
External Interrupt (INT2/INT3)	*1	# 18	FFFFB4 _H		
Serial I/O	*1	# 19	FFFFB0 _H	ICR04	0000B4 _H
External Interrupt (INT4/INT5)	*1	# 20	FFFFAC _H		
Input Capture 0	*1	# 21	FFFFA8 _H	ICR05	0000B5 _H
8/16-bit PPG 0/1	N/A	# 22	FFFFA4 _H		
Output Compare 0	*1	# 23	FFFFA0 _H	ICR06	0000B6 _H
8/16-bit PPG 2/3	N/A	# 24	FFFF9C _H		
External Interrupt (INT6/INT7)	*1	# 25	FFFF98 _H	ICR07	0000B7 _H
Input Capture 1	*1	# 26	FFFF94 _H		
8/16-bit PPG 4/5	N/A	# 27	FFFF90 _H	ICR08	0000B8 _H
Output Compare 1	*1	# 28	FFFF8C _H		
8/16-bit PPG 6/7	N/A	# 29	FFFF88 _H	ICR09	0000B9 _H
Input Capture 2	*1	# 30	FFFF84 _H		
8/16-bit PPG 8/9	N/A	# 31	FFFF80 _H	ICR10	0000BA _H
Output Compare 2	*1	# 32	FFFF7C _H		
Input Capture 3	*1	# 33	FFFF78 _H	ICR11	0000BB _H
8/16-bit PPG A/B	N/A	# 34	FFFF74 _H		
Output Compare 3	*1	# 35	FFFF70 _H	ICR12	0000BC _H
16-bit Reload Timer 1	*1	# 36	FFFF6C _H		
UART 0 RX	*2	# 37	FFFF68 _H	ICR13	0000BD _H
UART 0 TX	*1	# 38	FFFF64 _H		
UART 1 RX	*2	# 39	FFFF60 _H	ICR14	0000BE _H
UART 1 TX	*1	# 40	FFFF5C _H		
Flash Memory	N/A	# 41	FFFF58 _H	ICR15	0000BF _H
Delayed interrupt	N/A	# 42	FFFF54 _H		

*1: The interrupt request flag is cleared by the EI²OS interrupt clear signal.

*2: The interrupt request flag is cleared by the EI²OS interrupt clear signal. A stop request is available.

N/A: The interrupt request flag is not cleared by the EI²OS interrupt clear signal.

Note: • For a peripheral module with two interrupt for a single interrupt number, both interrupt request flags are cleared by the EI²OS interrupt clear signal.

- At the end of EI²OS, the EI²OS clear signal will be asserted for all the interrupt flags assigned to the same interrupt number. If one interrupt flag starts the EI²OS and in the meantime another interrupt flag is set by hardware event, the later event is lost because the flag is cleared by the EI²OS clear signal caused by the first event. So it is recommended not to use the EI²OS for this interrupt number.

www.DataSheet4U.com

- If EI²OS is enabled, EI²OS is initiated when one of the two interrupt signals in the same interrupt control register (ICR) is asserted. This means that different interrupt sources share the same EI²OS Descriptor which should be unique for each interrupt source. For this reason, when one interrupt source uses the EI²OS, the other interrupt should be disabled.

MB90595/595G Series

ELECTRICAL CHARACTERISTICS

1. Absolute Maximum Ratings

($V_{SS} = AV_{SS} = 0\text{ V}$)

Parameter	Symbol	Rating		Unit	Remarks
		Min.	Max.		
Power supply voltage	V_{CC}	$V_{SS} - 0.3$	$V_{SS} + 6.0$	V	
	AV_{CC}	$V_{SS} - 0.3$	$V_{SS} + 6.0$	V	$V_{CC} = AV_{CC}$ *1
	$AVRH, AVRL$	$V_{SS} - 0.3$	$V_{SS} + 6.0$	V	$AV_{CC} \geq AVRH/L,$ $AVRH \geq AVRL$ *1
	DV_{CC}	$V_{SS} - 0.3$	$V_{SS} + 6.0$	V	$V_{CC} \geq DV_{CC}$
Input voltage	V_I	$V_{SS} - 0.3$	$V_{SS} + 6.0$	V	*2
Output voltage	V_O	$V_{SS} - 0.3$	$V_{SS} + 6.0$	V	*2
Clamp Current	I_{CLAMP}	-2.0	2.0	mA	
"L" level max. output current	I_{OL1}	—	15	mA	Normal output *3
"L" level avg. output current	I_{OLAV1}	—	4	mA	Normal output, average value *4
"L" level max. output current	I_{OL2}	—	40	mA	High current output *3
"L" level avg. output current	I_{OLAV2}	—	30	mA	High current output, average value *4
"L" level max. overall output current	$\sum I_{OL1}$	—	100	mA	Total normal output
"L" level max. overall output current	$\sum I_{OL2}$	—	330	mA	Total high current output
"L" level avg. overall output current	$\sum I_{OLAV1}$	—	50	mA	Total normal output, average value *5
"L" level avg. overall output current	$\sum I_{OLAV2}$	—	250	mA	Total high current output, average value *5
"H" level max. output current	I_{OH1}	—	-15	mA	Normal output *3
"H" level avg. output current	I_{OHAV1}	—	-4	mA	Normal output, average value *4
"H" level max. output current	I_{OH2}	—	-40	mA	High current output *3
"H" level avg. output current	I_{OHAV2}	—	-30	mA	High current output, average value *4
"H" level max. overall output current	$\sum I_{OH1}$	—	-100	mA	Total normal output
"H" level max. overall output current	$\sum I_{OH2}$	—	-330	mA	Total high current output
"H" level avg. overall output current	$\sum I_{OHAV1}$	—	-50	mA	Total normal output, average value *5
"H" level avg. overall output current	$\sum I_{OHAV2}$	—	-250	mA	Total high current output, average value *5
Power consumption	P_D	—	500	mW	MB90F598/F598G
		—	400	mW	MB90598
Operating temperature	T_A	-40	+85	°C	
Storage temperature	T_{STG}	-55	+150	°C	

*1: AV_{CC} , $AVRH$ and $AVRL$ does not exceed V_{CC} and $AVRL$ does not exceed $AVRH$.

*2: V_I and V_O should not exceed $V_{CC} + 0.3V$. V_I should not exceed the specified ratings. However if the maximum current to/from an input is limited by some means with external components, the I_{CLAMP} rating supercedes the V_I rating.

*3: The maximum output current is a peak value for a corresponding pin.

*4: Average output current is an average current value observed for a 100 ms period for a corresponding pin.

*5: Total average current is an average current value observed for a 100 ms period for all corresponding pins.

Note: Average output current = operating current \times operating efficiency

WARNING: Semiconductor devices can be permanently damaged by application of stress (voltage, current, temperature, etc.) in excess of absolute maximum ratings. Do not exceed these ratings.

2. Recommended Conditions

($V_{SS} = AV_{SS} = 0\text{ V}$)

Parameter	Symbol	Value			Unit	Remarks
		Min.	Typ.	Max.		
Power supply voltage	V_{CC}	4.5	5.0	5.5	V	Under normal operation
	AV_{CC}	3.0	—	5.5	V	Maintains RAM data in stop mode
Smooth capacitor	C_S	0.022	0.1	1.0	μF	*
Operating temperature	T_A	-40	—	+85	$^{\circ}\text{C}$	

*: Use a ceramic capacitor or a capacitor with equivalent frequency characteristics. The smoothing capacitor to be connected to the V_{CC} pin must have a capacitance value higher than C_S .

WARNING: The recommended operating conditions are required in order to ensure the normal operation of the semiconductor device. All of the device's electrical characteristics are warranted when the device is operated within these ranges.

Always use semiconductor devices within their recommended operating condition ranges. Operation outside these ranges may adversely affect reliability and could result in device failure.

No warranty is made with respect to uses, operating conditions, or combinations not represented on the data sheet. Users considering application outside the listed conditions are advised to contact their FUJITSU representatives beforehand.

• C Pin Connection Diagram

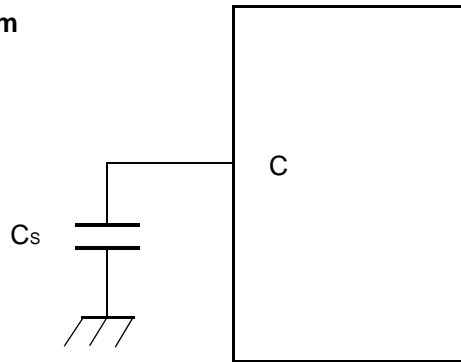

MB90595/595G Series

3. DC Characteristics

($V_{CC} = 5.0\text{ V} \pm 10\%$, $V_{SS} = AV_{SS} = 0\text{V}$, $T_A = -40\text{ }^\circ\text{C}$ to $+85\text{ }^\circ\text{C}$)

Parameter	Symbol	Pin name	Condition	Value			Unit	Remarks
				Min.	Typ.	Max.		
Input H voltage	V_{IHS}	CMOS hysteresis input pin	—	$0.8 V_{CC}$	—	$V_{CC} + 0.3$	V	
	V_{IHM}	MD input pin	—	$V_{CC} - 0.3$	—	$V_{CC} + 0.3$	V	
Input L voltage	V_{ILS}	CMOS hysteresis input pin	—	$V_{SS} - 0.3$	—	$0.2 V_{CC}$	V	
	V_{ILM}	MD input pin	—	$V_{SS} - 0.3$	—	$V_{SS} + 0.3$	V	
Output H voltage	V_{OH1}	Output pins except P70 to P87	$V_{CC} = 4.5\text{ V}$, $I_{OH1} = -4.0\text{ mA}$	$V_{CC} - 0.5$	—	—	V	
Output H voltage	V_{OH2}	P70 to P87	$V_{CC} = 4.5\text{ V}$, $I_{OH2} = -30.0\text{ mA}$	$V_{CC} - 0.5$	—	—	V	
Output L voltage	V_{OL1}	Output pins except P70 to P87	$V_{CC} = 4.5\text{ V}$, $I_{OL1} = 4.0\text{ mA}$	—	—	0.4	V	
Output L voltage	V_{OL2}	P70 to P87	$V_{CC} = 4.5\text{ V}$, $I_{OL2} = 30.0\text{ mA}$	—	—	0.5	V	
Input leak current	I_{IL}		$V_{CC} = 5.5\text{ V}$, $V_{SS} < V_I < V_{CC}$	-5	—	5	μA	
Power supply current *	I_{CC}	V_{CC}	$V_{CC} = 5.0\text{ V} \pm 10\%$, Internal frequency: 16 MHz, At normal operating	—	35	60	mA	MB90598
				—	50	90	mA	MB90F598
				—	40	60	mA	MB90F598G
	I_{CCS}		$V_{CC} = 5.0\text{ V} \pm 10\%$, Internal frequency: 16 MHz, At sleep	—	11	18	mA	
	I_{CTS}		$V_{CC} = 5.0\text{ V} \pm 1\%$, Internal frequency: 2 MHz, At timer mode	—	0.3	0.6	mA	
	I_{CCH}		$V_{CC} = 5.0\text{ V} \pm 10\%$, At stop, $T_A = 25\text{ }^\circ\text{C}$	—	—	20	μA	
I_{CCH2}	$V_{CC} = 5.0\text{ V} \pm 10\%$, At Hardware stand-by mode, $T_A = 25\text{ }^\circ\text{C}$	—	—	20	μA	MB90598 MB90F598		
		—	50	100	μA	MB90F598G		
Input capacity	C_{IN}	Other than C, AV_{CC} , AV_{SS} , AV_{RH} , AV_{RL} , V_{CC} , V_{SS} , DV_{CC} , DV_{SS} , P70 to P87	—	—	5	15	pF	
		P70 to P87	—	—	15	30	pF	

*: Current values are tentative and subject to change without notice according to improvements in the characteristics. The power supply current testing conditions are when using the external clock.

4. AC Characteristics

(1) Clock Timing

($V_{CC} = 5.0\text{ V} \pm 10\%$, $V_{SS} = AV_{SS} = 0\text{V}$, $T_A = -40\text{ }^\circ\text{C}$ to $+85\text{ }^\circ\text{C}$)

Parameter	Symbol	Pin name	Value			Unit	Remarks
			Min.	Typ.	Max.		
Oscillation frequency	f_c	X0, X1	3	—	5	MHz	When using an oscillation circuit
			3		16	MHz	When using an external clock
Oscillation cycle time	t_{CYL}	X0, X1	200	—	333	ns	When using an oscillation circuit
			62.5		333	ns	When using an external clock
Frequency deviation with PLL *	Δf	—	—	—	5	%	
Input clock pulse width	P_{WH}, P_{WL}	X0	10	—	—	ns	Duty ratio is about 30 to 70%.
Input clock rise and fall time	t_{CR}, t_{CF}	X0	—	—	5	ns	When using external clock
Machine clock frequency	f_{CP}	—	1.5	—	16	MHz	
Machine clock cycle time	t_{CP}	—	62.5	—	666	ns	

*: Frequency deviation indicates the maximum frequency difference from the target frequency when using a multiplied clock.

$$\Delta f = \frac{|\alpha|}{f_0} \times 100\%$$

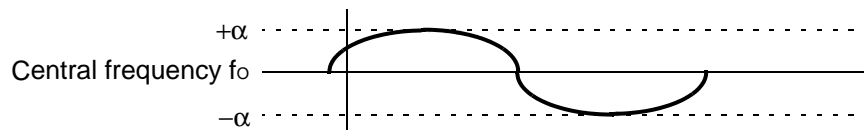

• Clock Timing

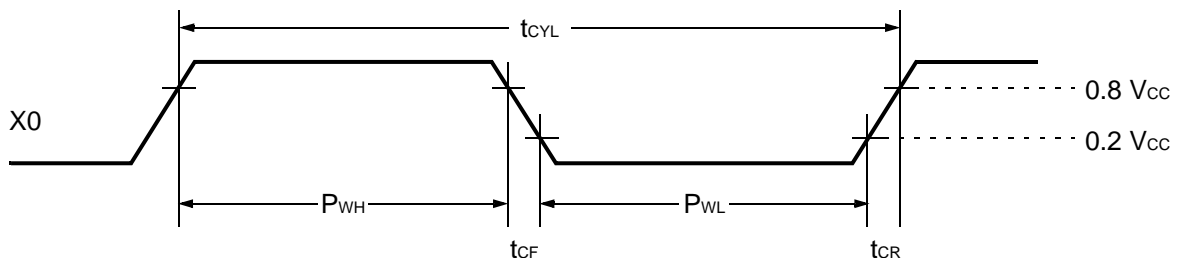

Example of Oscillation circuit

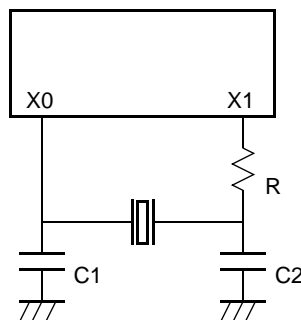

MB90595/595G Series

• **Guaranteed operation range**

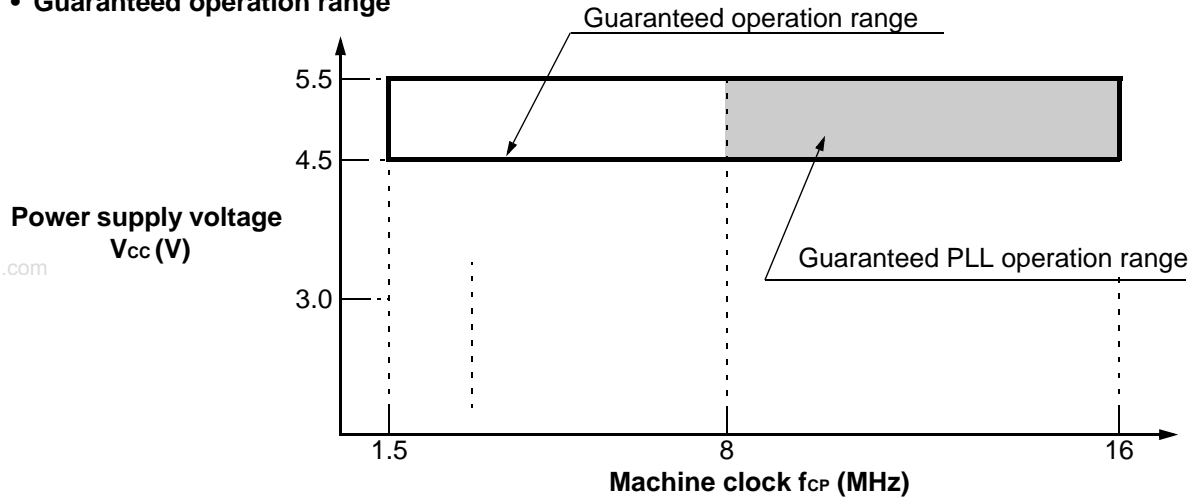

• **External clock frequency and machine clock frequency**

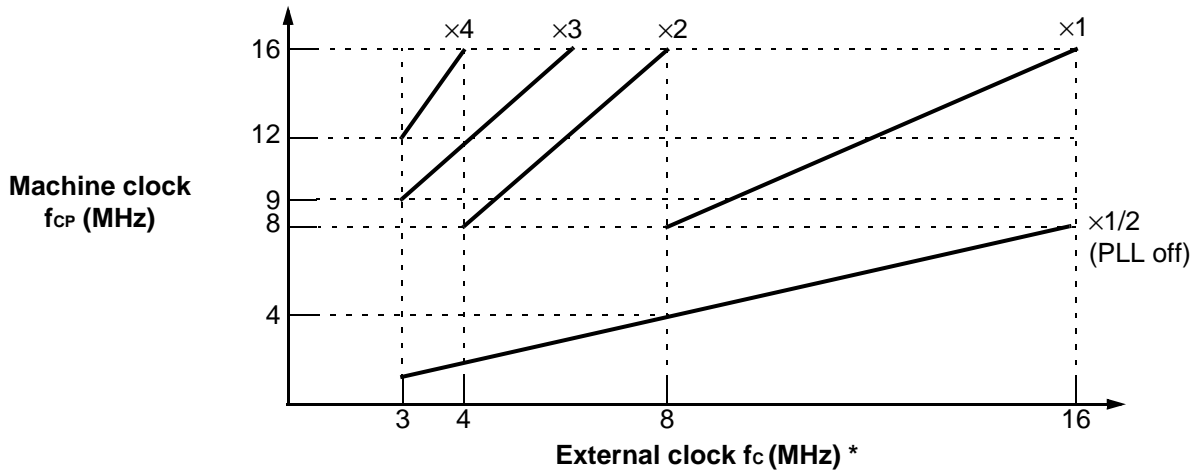

*: When using the oscillation circuit, the maximum oscillation clock frequency is 5 MHz.

AC characteristics are set to the measured reference voltage values below.

• **Input signal waveform**

Hysteresis Input Pin

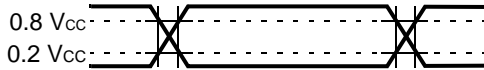

• **Output signal waveform**

Output Pin

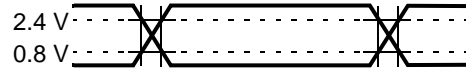

MB90595/595G Series

(2) Reset and Hardware Standby Input

($V_{CC} = 5.0 V \pm 10\%$, $V_{SS} = AV_{SS} = 0V$, $T_A = -40\text{ }^\circ\text{C}$ to $+85\text{ }^\circ\text{C}$)

Parameter	Symbol	Pin name	Value		Unit	Remarks
			Min.	Max.		
Reset input time	t_{RSTL}	\overline{RST}	$16 t_{CP}^{*1}$	—	ns	Under normal operation
			Oscillation time of oscillator ^{*2} + $16 t_{CP}^{*1}$	—	ms	In stop mode
Hardware standby input time	t_{HSTL}	\overline{HST}	$16 t_{CP}^{*1}$	—	ns	Under normal operation
			Oscillation time of oscillator ^{*2} + $16 t_{CP}^{*1}$	—	ms	In stop mode

*1: " t_{CP} " represents one cycle time of the machine clock.

No reset can fully initialize the Flash Memory if it is performing the automatic algorithm.

*2: Oscillation time of oscillator is time that the amplitude reached the 90%.

In the crystal oscillator, the oscillation time is between several ms to tens of ms. In FAR / ceramic oscillator, the oscillation time is between hundreds of μs to several ms. In the external clock, the oscillation time is 0 ms.

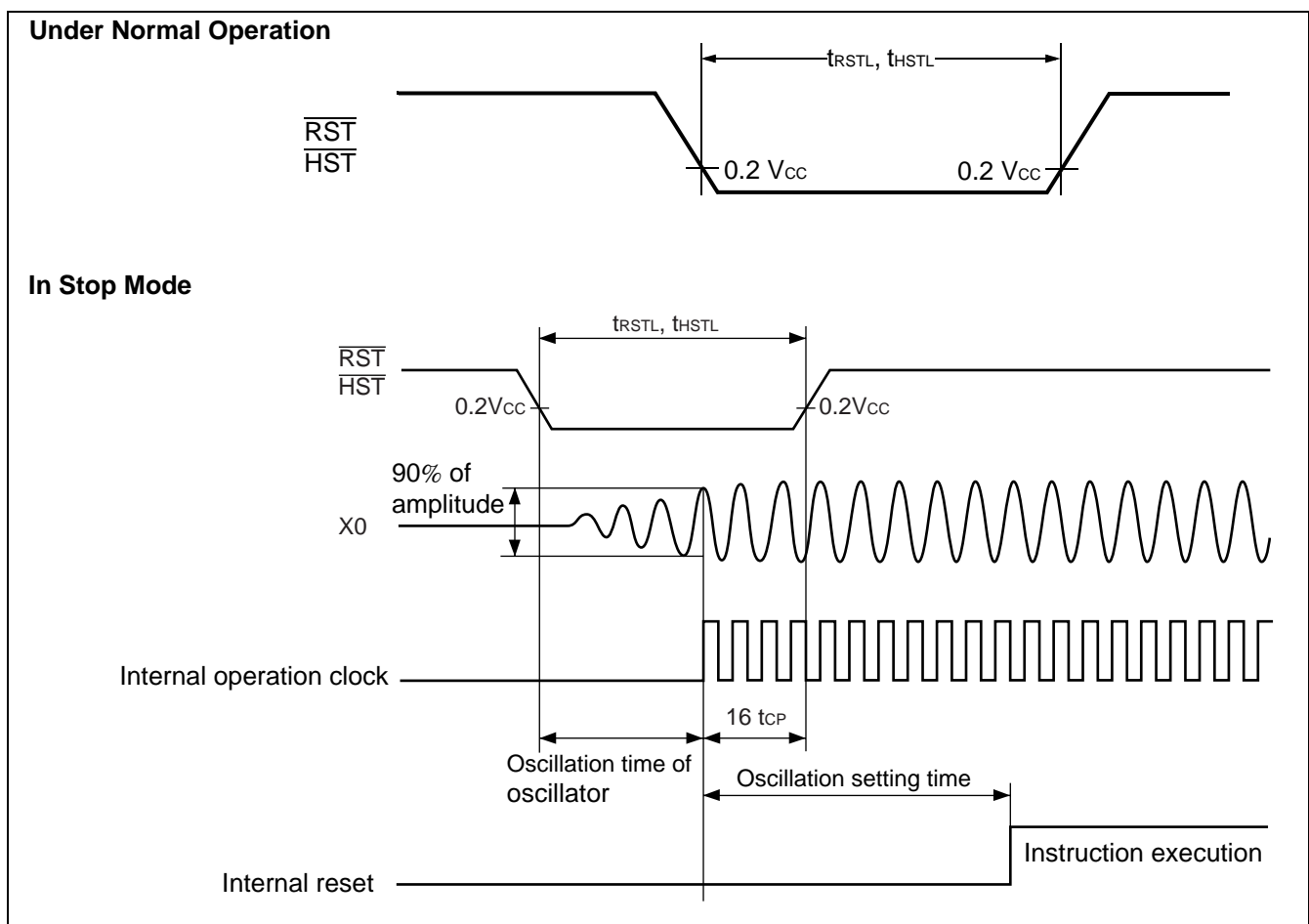

MB90595/595G Series

(3) Power On Reset

($V_{CC} = 5.0\text{ V} \pm 10\%$, $V_{SS} = AV_{SS} = 0\text{ V}$, $T_A = -40\text{ }^\circ\text{C}$ to $+85\text{ }^\circ\text{C}$)

Parameter	Symbol	Pin name	Condition	Value		Unit	Remarks
				Min.	Max.		
Power on rise time	t_R	V_{CC}	—	0.05	30	ms	*
Power off time	t_{OFF}	V_{CC}	—	50	—	ms	Due to repetitive operation

*: V_{CC} must be kept lower than 0.2 V before power-on.

Note: • The above values are used for creating a power-on reset.

www.DataSheet4U.com

• Some registers in the device are initialized only upon a power-on reset. To initialize these register, turn on the power supply using the above values.

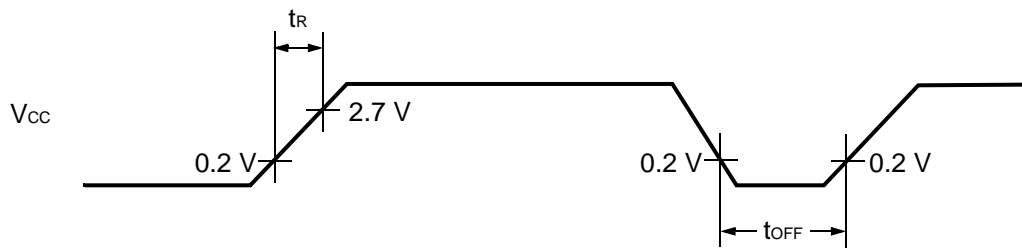

Sudden changes in the power supply voltage may cause a power-on reset.

To change the power supply voltage while the device is in operation, it is recommended to raise the voltage smoothly to suppress fluctuations as shown below.

In this case, change the supply voltage with the PLL clock not used. If the voltage drop is 1 V or fewer per second, however, you can use the PLL clock.

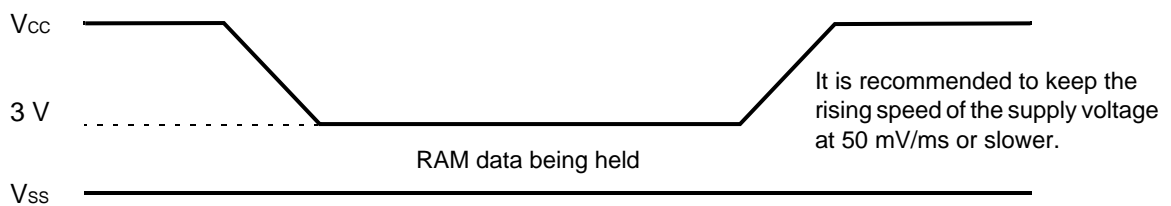

MB90595/595G Series

(4) UART0/1, Serial I/O Timing

($V_{CC} = 5.0 V \pm 10\%$, $V_{SS} = AV_{SS} = 0V$, $T_A = -40\text{ }^\circ\text{C}$ to $+85\text{ }^\circ\text{C}$)

Parameter	Symbol	Pin name	Condition	Value		Unit	Remarks
				Min.	Max.		
Serial clock cycle time	t_{SCYC}	SCK0 to SCK2	Internal clock operation output pins are $C_L = 80\text{ pF} + 1\text{ TTL}$.	8 t_{CP}	—	ns	
SCK \downarrow \Rightarrow SOT delay time	t_{SLOV}	SCK0 to SCK2, SOT0 to SOT2		-80	80	ns	
Valid SIN \Rightarrow SCK \uparrow	t_{IVSH}	SCK0 to SCK2, SIN0 to SIN2		100	—	ns	
SCK \uparrow \Rightarrow Valid SIN hold time	t_{SHIX}	SCK0 to SCK2, SIN0 to SIN2		60	—	ns	
Serial clock "H" pulse width	t_{SHSL}	SCK0 to SCK2	External clock operation output pins are $C_L = 80\text{ pF} + 1\text{ TTL}$.	4 t_{CP}	—	ns	
Serial clock "L" pulse width	t_{LSLH}	SCK0 to SCK2		4 t_{CP}	—	ns	
SCK \downarrow \Rightarrow SOT delay time	t_{SLOV}	SCK0 to SCK2, SOT0 to SOT2		—	150	ns	
Valid SIN \Rightarrow SCK \uparrow	t_{IVSH}	SCK0 to SCK2, SIN0 to SIN2		60	—	ns	
SCK \uparrow \Rightarrow Valid SIN hold time	t_{SHIX}	SCK0 to SCK2, SIN0 to SIN2		60	—	ns	

- Note: 1. AC characteristic in CLK synchronized mode.
 2. C_L is load capacity value of pins when testing.
 3. t_{CP} is the machine cycle (Unit: ns).

• Internal Shift Clock Mode

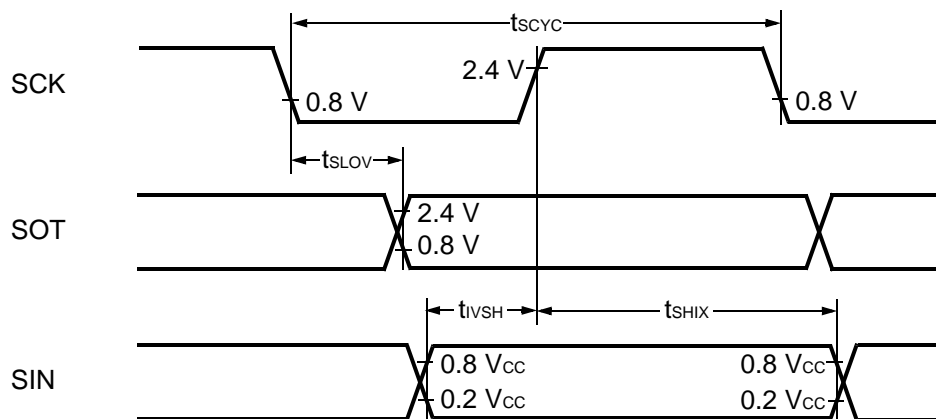

MB90595/595G Series

• External Shift Clock Mode

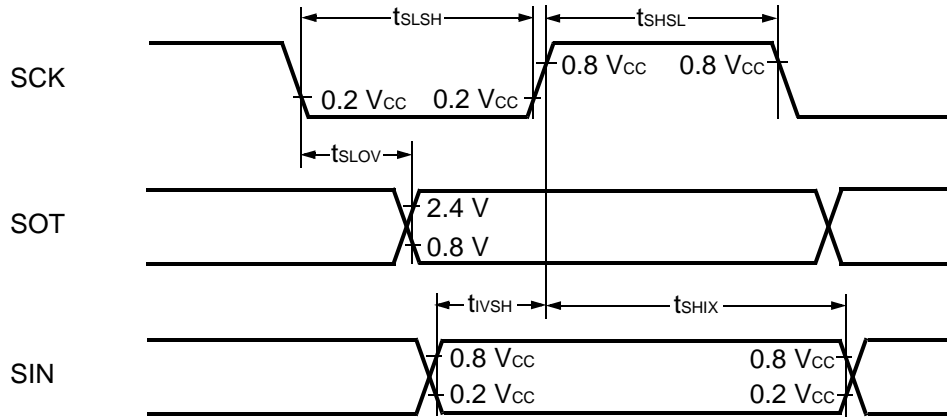

(5) Timer Input Timing

($V_{CC} = 5.0 V \pm 10\%$, $V_{SS} = AV_{SS} = 0V$, $T_A = -40^\circ C$ to $+85^\circ C$)

Parameter	Symbol	Pin name	Condition	Value		Unit	Remarks
				Min.	Max.		
Input pulse width	t_{TIWH}	TIN0, TIN1	—	$4 t_{CP}$	—	ns	
	t_{TIWL}	IN0 to IN3					

• Timer Input Timing

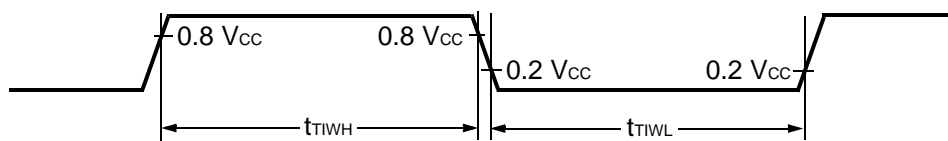

MB90595/595G Series

(6) Trigger Input Timing

($V_{CC} = 5.0\text{ V} \pm 10\%$, $V_{SS} = AV_{SS} = 0\text{V}$, $T_A = -40\text{ }^\circ\text{C}$ to $+85\text{ }^\circ\text{C}$)

Parameter	Symbol	Pin name	Condition	Value		Unit	Remarks
				Min.	Max.		
Input pulse width	t_{TRGH}	INT0 to INT7, ADTG	—	$5 t_{CP}$	—	ns	Under normal operation
	t_{TRGL}			1	—	μs	In stop mode

• Trigger Input Timing

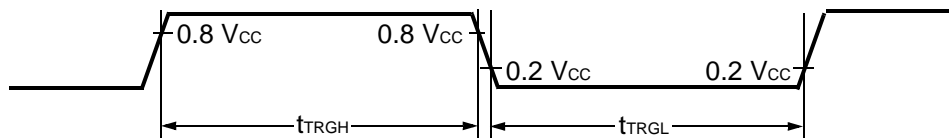

(7) Slew Rate High Current Outputs

($V_{CC} = 5.0\text{ V} \pm 10\%$, $V_{SS} = AV_{SS} = 0\text{V}$, $T_A = -40\text{ }^\circ\text{C}$ to $+85\text{ }^\circ\text{C}$)

Parameter	Symbol	Pin name	Condition	Value			Unit	Remarks
				Min.	Typ.	Max.		
Output Rise/Fall time	t_{R2} t_{F2}	Port P70 to P77, Port P80 to P87	—	15	40	150	ns	

• Slew Rate Output Timing

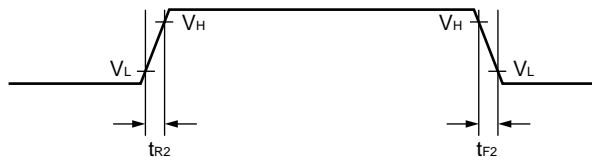

$$V_H = V_{OL2} + 0.1 \times (V_{OH2} - V_{OL2})$$

$$V_L = V_{OL2} + 0.9 \times (V_{OH2} - V_{OL2})$$

MB90595/595G Series

5. A/D Converter

($V_{CC} = AV_{CC} = 5.0\text{ V} \pm 10\%$, $V_{SS} = AV_{SS} = 0\text{ V}$, $3.0\text{ V} \leq AVR_{H} - AVR_{L}$, $T_A = -40\text{ }^{\circ}\text{C}$ to $+85\text{ }^{\circ}\text{C}$)

Parameter	Symbol	Pin name	Value			Unit	Remarks
			Min.	Typ.	Max.		
Resolution	—	—	—	—	10	bit	
Conversion error	—	—	—	—	± 5.0	LSB	
Nonlinearity error	—	—	—	—	± 2.5	LSB	
Differential linearity error	—	—	—	—	± 1.9	LSB	
Zero transition voltage	V_{OT}	AN0 to AN7	$AV_{RL} - 3.5$	$AV_{RL} + 0.5$	$AV_{RL} + 4.5$	mV	
Full scale transition voltage	V_{FST}	AN0 to AN7	$AV_{RH} - 6.5$	$AV_{RH} - 1.5$	$AV_{RH} + 1.5$	mV	
Conversion time	—	—	—	$352t_{CP}$	—	ns	
Sampling time	—	—	—	$64t_{CP}$	—	ns	
Analog port input current	I_{AIN}	AN0 to AN7	-10	—	10	μA	
Analog input voltage range	V_{AIN}	AN0 to AN7	AV_{RL}	—	AV_{RH}	V	
Reference voltage range	—	AV_{RH}	$AV_{RL} + 2.7$	—	AV_{CC}	V	
	—	AV_{RL}	0	—	$AV_{RH} - 2.7$	V	
Power supply current	I_A	AV_{CC}	—	5	—	mA	
	I_{AH}	AV_{CC}	—	—	5	μA	*
Reference voltage current	I_R	AV_{RH}	—	400	600	μA	MB90V595 MB90V595G MB90F598 MB90F598G
			—	140	600	μA	MB90598
	I_{RH}	AV_{RH}	—	—	5	μA	*
Offset between input channels	—	AN0 to AN7	—	—	4	LSB	

*: When not operating A/D converter, this is the current ($V_{CC} = AV_{CC} = AVR_{H} = 5.0\text{ V}$) when the CPU is stopped.

6. A/D Converter Glossary

Resolution: Analog changes that are identifiable with the A/D converter

Linearity error: The deviation of the straight line connecting the zero transition point ("00 0000 0000" ↔ "00 0000 0001") with the full-scale transition point ("11 1111 1110" ↔ "11 1111 1111") from actual conversion characteristics

Differential linearity error: The deviation of input voltage needed to change the output code by 1 LSB from the theoretical value

Total error: The total error is defined as a difference between the actual value and the theoretical value, which includes zero-transition error/full-scale transition error and linearity error.

www.DataSheet4U.com

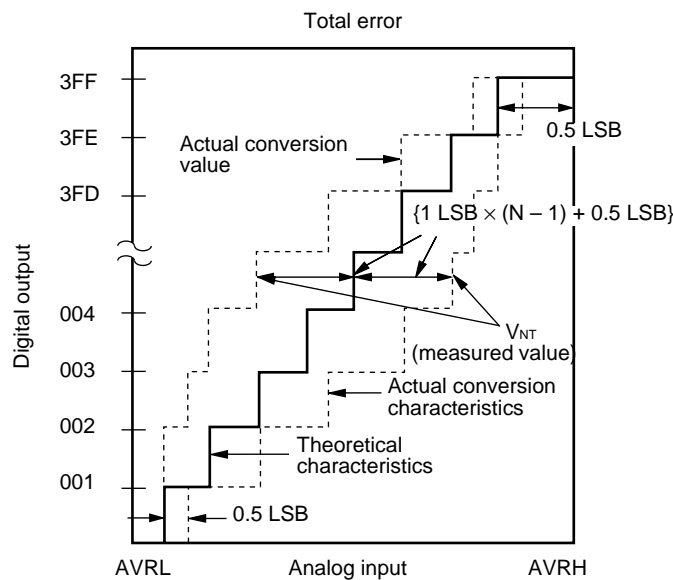

$$1 \text{ LSB} = (\text{Theoretical value}) \frac{\text{AVRH} - \text{AVRL}}{1024} \text{ [V]}$$

$$\text{Total error for digital output } N = \frac{V_{NT} - \{1 \text{ LSB} \times (N - 1) + 0.5 \text{ LSB}\}}{1 \text{ LSB}} \text{ [LSB]}$$

$$V_{0T} (\text{Theoretical value}) = \text{AVRL} + 0.5 \text{ LSB [V]}$$

V_{NT} : Voltage at a transition of digital output from (N - 1) to N

$$V_{FST} (\text{Theoretical value}) = \text{AVRH} - 1.5 \text{ LSB [V]}$$

(Continued)

MB90595/595G Series

(Continued)

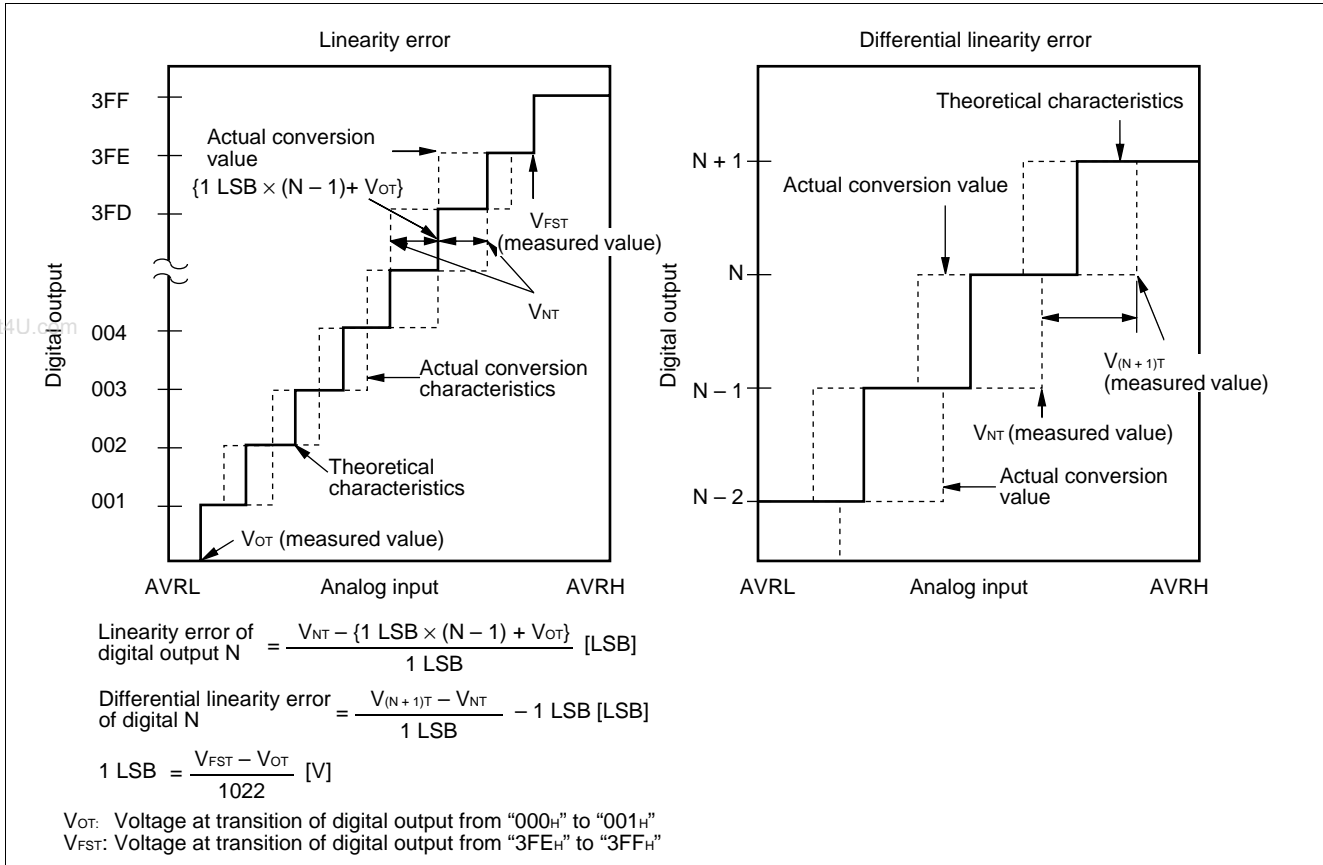

7. Notes on Using A/D Converter

Select the output impedance value for the external circuit of analog input according to the following conditions, :

- Output impedance values of the external circuit of 15 kΩ or lower are recommended.
- When capacitors are connected to external pins, the capacitance of several thousand times the internal capacitor value is recommended to minimized the effect of voltage distribution between the external capacitor and internal capacitor.

When the output impedance of the external circuit is too high, the sampling period for analog voltages may not be sufficient (sampling period = 4.00 μs @ machine clock of 16 MHz).

• Equipment of analog input circuit model

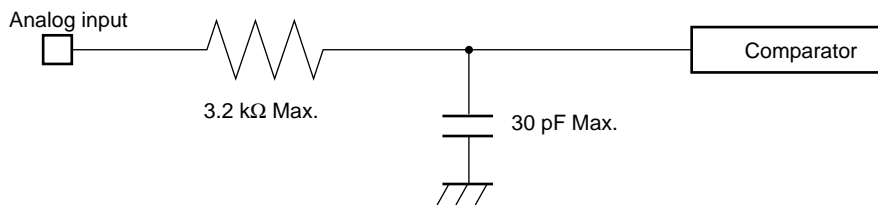

• Error

The smaller the $|AVRH - AVRL|$, the greater the error would become relatively.

MB90595/595G Series

■ ORDERING INFORMATION

Part number	Package	Remarks
MB90598PF MB90F598PF MB90F598GPF	100-pin Plastic QFP (FPT-100P-M06)	
MB90V595CR MB90V595GCR	256-pin Ceramic PGA (PGA-256C-A01)	For evaluation

MB90595/595G Series

PACKAGE DIMENSION

100-pin plastic QFP
(FPT-100P-M06)

Note: This package dimension is for the reference. Please consult separately about a formal version.

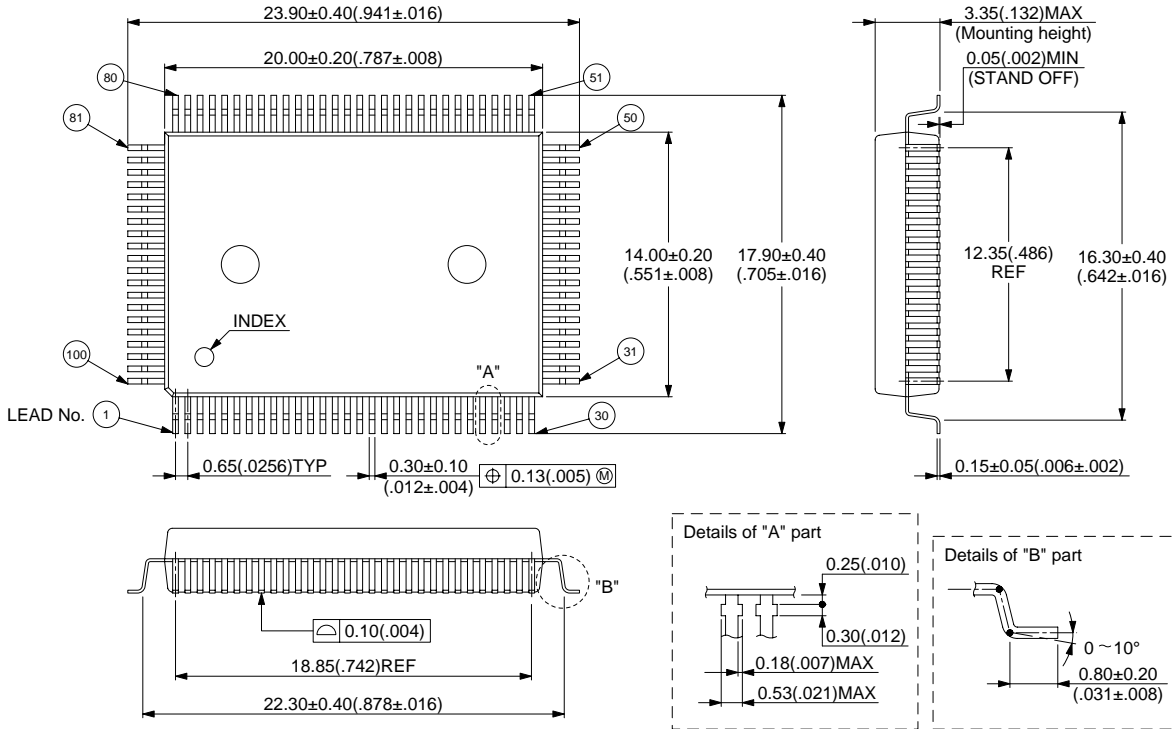

© 2000 FUJITSU LIMITED F100008-3C-3

Dimensions in mm (inches)

FUJITSU LIMITED

For further information please contact:

Japan

FUJITSU LIMITED
Corporate Global Business Support Division
Electronic Devices
Shinjuku Dai-Ichi Seimei Bldg. 7-1,
Nishishinjuku 2-chome, Shinjuku-ku,
Tokyo 163-0721, Japan
Tel: +81-3-5322-3347
Fax: +81-3-5322-3386

<http://edevice.fujitsu.com/>

North and South America

FUJITSU MICROELECTRONICS, INC.
3545 North First Street,
San Jose, CA 95134-1804, U.S.A.
Tel: +1-408-922-9000
Fax: +1-408-922-9179

Customer Response Center
Mon. - Fri.: 7 am - 5 pm (PST)
Tel: +1-800-866-8608
Fax: +1-408-922-9179

<http://www.fujitsumicro.com/>

Europe

FUJITSU MICROELECTRONICS EUROPE GmbH
Am Siebenstein 6-10,
D-63303 Dreieich-Buchsschlag,
Germany
Tel: +49-6103-690-0
Fax: +49-6103-690-122

<http://www.fujitsu-fme.com/>

Asia Pacific

FUJITSU MICROELECTRONICS ASIA PTE. LTD.
#05-08, 151 Lorong Chuan,
New Tech Park,
Singapore 556741
Tel: +65-281-0770
Fax: +65-281-0220

<http://www.fmap.com.sg/>

Korea

FUJITSU MICROELECTRONICS KOREA LTD.
1702 KOSMO TOWER, 1002 Daechi-Dong,
Kangnam-Gu, Seoul 135-280
Korea
Tel: +82-2-3484-7100
Fax: +82-2-3484-7111

F0101

© FUJITSU LIMITED Printed in Japan

All Rights Reserved.

The contents of this document are subject to change without notice. Customers are advised to consult with FUJITSU sales representatives before ordering.

The information and circuit diagrams in this document are presented as examples of semiconductor device applications, and are not intended to be incorporated in devices for actual use. Also, FUJITSU is unable to assume responsibility for infringement of any patent rights or other rights of third parties arising from the use of this information or circuit diagrams.

The contents of this document may not be reproduced or copied without the permission of FUJITSU LIMITED.

FUJITSU semiconductor devices are intended for use in standard applications (computers, office automation and other office equipments, industrial, communications, and measurement equipments, personal or household devices, etc.).

CAUTION:

Customers considering the use of our products in special applications where failure or abnormal operation may directly affect human lives or cause physical injury or property damage, or where extremely high levels of reliability are demanded (such as aerospace systems, atomic energy controls, sea floor repeaters, vehicle operating controls, medical devices for life support, etc.) are requested to consult with FUJITSU sales representatives before such use. The company will not be responsible for damages arising from such use without prior approval.

Any semiconductor devices have inherently a certain rate of failure. You must protect against injury, damage or loss from such failures by incorporating safety design measures into your facility and equipment such as redundancy, fire protection, and prevention of over-current levels and other abnormal operating conditions.

If any products described in this document represent goods or technologies subject to certain restrictions on export under the Foreign Exchange and Foreign Trade Control Law of Japan, the prior authorization by Japanese government should be required for export of those products from Japan.