

# 32-bit Microcontroller

CMOS

## FR60Lite MB91245/S Series

### MB91247/247S/248/248S/F248/F248S/MB91V245A

#### ■ OVERVIEW

MB91245/S series is Fujitsu's general-purpose 32-bit RISC microcontroller, which is designed for embedded control applications that require high-speed real-time processing of consumer appliances. This microcontroller uses FR60Lite as its CPU, compatible with other products in the FR\* family.

This series incorporates an LCD controller and stepping motor controller.

\* : FR, the abbreviation of FUJITSU RISC controller, is a line of products of FUJITSU Limited.

#### ■ FEATURES

##### • FR60Lite CPU

- 32-bit RISC, load/store architecture, 5-stage pipeline
- Maximum operating frequency : 32 MHz (Source oscillation is 4 MHz with x8 multiplier – PLL clock multiplier system)
- 16-bit fixed-length instructions (basic instructions)
- Instruction execution speed : 1 instruction per cycle
- Instruction set optimized for embedded application : Memory-to-memory transfer, bit manipulation, barrel shift instructions etc.
- Instructions adapted for programming C language : Function entry/exit instructions, multiple-register load/store instructions.
- Register interlock function : Easier assembler coding enabled
- Built-in multiplier supported at the instruction level
  - Signed 32-bit multiplication : 5 cycles
  - Signed 16-bit multiplication : 3 cycles

(Continued)

Be sure to refer to the "Check Sheet" for the latest cautions on development.

"Check Sheet" is seen at the following support page

URL : <http://www.fujitsu.com/global/services/microelectronics/product/micom/support/index.html>

"Check Sheet" lists the minimal requirement items to be checked to prevent problems beforehand in system development.

# MB91245/S Series

(Continued)

- Interrupt (PC/PS save) : 6 cycles (16 priority levels)
- Harvard architecture allowing program access and data access to be executed simultaneously.
- Instruction set compatible with FR family

## • Internal Peripheral Functions

- Internal ROM size & ROM type
  - MASK ROM : 256 Kbytes (MB91248/S) / 128 Kbytes (MB91247/S)
  - Flash Memory : 256 Kbytes
- Internal RAM size : 16 Kbytes (MB91248/S, MB91F248/S) / 8 Kbytes (MB91247/S) / 32 Kbytes (MB91V245A)
- General-purpose ports : up to 120 ports (includes 4 input-only ports)
- 8/10-bit A/D converter (Sequential comparison type)
  - 8/10-bit resolution : 32 channels
  - Conversion time : 3  $\mu$ s (16/32 MHz)
  - Set the PLL multiplier and the division ratio of peripheral circuit clocks so that the above conversion time is achieved.
  - 32 MHz : Source oscillation (4 MHz) with x8 multiplier, divided by 1
  - 16 MHz : Source oscillation with x8 multiplier, divided by 2
- External interrupt input : 8 channels
- Bit search module (for REALOS)
  - Search function to locate the position of the first bit that changes from “1” to “0” in one word, from the MSB (Most Significant Bit)
- UART (full duplex double buffer type) : 1 channel
  - Parity enable/disable selectable
  - Asynchronous clock operation (start-stop synchronization) and synchronous clock operation selectable
  - Dedicated baud-rate timer (U-Timer) embedded in each channel
  - External clock can be used as transfer clock
  - Parity, frame, overrun error detection functions provided
- LIN-UART (full duplex double buffer type) : 3 channels
  - Synchronous/asynchronous clock operations selectable
  - Sync-break detection
  - Dedicated built-in baud-rate generator
- Stepping motor controller (SMC) : 6 channels
  - 8-bit PWM with 4 high-current outputs for each channel
- 8/16-bit PPG timer : 8/4 channels
- 16-bit reload timer : 3 channels
- 16-bit free-run timer : 2 channels (ICU/OCU linkage)
- 16-bit pulse width counter : 1 channel
- Input capture : 4 channels (linked to ch.0 and ch.1 of free-run timer)
  - ch.0 linked to PWC
- Output compare : 2 channels (linked to ch.0 of free-run timer)
- LCD controller : SEG00 to SEG31/COM0 to COM3 (shared with port)
- 16-bit timebase/watch dog timer
- Sound generator
- Real-time clock
- 32 kHz sub clock (not supported in single clock products)
- C-CAN : 2 channels
- Low power consumption modes : sleep mode, stop mode, watch mode
- Package : LQFP-144 (FPT-144P-M08)
- CMOS technology : 0.35  $\mu$ m
- Power supply voltage : 5 V (Internal logic : 3.3 V, I/O : 5.0 V (step-down circuit used))

# MB91245/S Series

## ■ PRODUCT LINEUP

A table below shows the product lineup of the MB91245/S series. Embedded peripheral functions which are not listed are common functions.

	MB91V245A	MB91247/S	MB91248/S	MB91F248/S
ROM/Flash size	External SRAM	128 Kbytes	256 Kbytes	256 Kbytes
RAM size	32 Kbytes	8 Kbytes	16 Kbytes	16 Kbytes
External interrupt	8 channels			
DMA Controller	5 channels			
A/D Converter	32 channels			
UART	1 channel			
LIN-UART	3 channels			
Stepping Motor Controller	6 channels			
8 /16-bit PPG	8 channels/4 channels			
16-bit Reload Timer	3 channels			
16-bit Free Run Timer	2 channels			
16-bit Pulse Width Counter	1 channel			
Input Capture Unit	4 channels			
Output Compare Unit	2 channels			
LCD Controller	4 COM, 32 SEG			
Sound Generator	1 channel			
Real Time Clock	Yes			
32 kHz Sub Clock	Yes	Yes/No (S series)	Yes/No (S series)	Yes/No (S series)
External bus	Addr 16 bits Data 16 bits			
Others	EVA device	MASK ROM product	MASK ROM product	Flash memory product
On Chip Debug Support Unit	DSU4	—		
C-CAN unit	2 channels 32-message buffer			

# MB91245/S Series

## PIN ASSIGNMENT

(TOP VIEW)

A04/SEG04/P24	1	144	P23/SEG03/A03
A05/SEG05/P25	2	143	P22/SEG02/A02
A06/SEG06/P26	3	142	P21/SEG01/A01
A07/SEG07/P27	4	141	P20/SEG00/A00
A08/SEG08/P30	5	140	PD7/COM3/PPG7
A09/SEG09/P31	6	139	PD6/COM2/PPG5
A10/SEG10/P32	7	138	PD5/COM1/PPG3
A11/SEG11/P33	8	137	PD4/COM0/PPG1
A12/SEG12/P34	9	136	PD3/IN3
A13/SEG13/P35	10	135	PD2/TIN2/IN2
A14/SEG14/P36	11	134	PD1/TIN1/IN1
A15/SEG15/P37	12	133	PD0/TIN0/IN0/PWCO
D08/SEG16/P10	13	132	PG3/TOT2/PPG6
D09/SEG17/P11	14	131	PG2/TOT1/PPG4
D10/SEG18/P12	15	130	PG1/TOT0/PPG2
X0A	16	129	X0
X1A	17	128	X1
Vcc	18	127	Vss
Vss	19	126	Vcc
Vcc3C	20	125	PG0/PPG0
D11/SEG19/P13	21	124	P47/SG0/SYSCLK
D12/SEG20/P14	22	123	P46/SGA/AS
D13/SEG21/P15	23	122	P57/OUT1/RDY
D14/SEG22/P16	24	121	P56/OUT0/WRI
D15/SEG23/P17	25	120	P55/SCK5/WRO
D00/INT0/SEG24/P00	26	119	P54/SOT5/RD
D01/INT1/SEG25/P01	27	118	P53/SIN5/CK1/CS3
D02/INT2/SEG26/P02	28	117	P52/SCK4/CS2
D03/INT3/SEG27/P03	29	116	P51/SOT4/CS1
D04/INT4/SEG28/P04	30	115	P50/SIN4/CK0/CS0
D05/INT5/SEG29/P05	31	114	P45/SCK3
D06/SEG30/P06	32	113	P44/SOT3
D07/ATG/SEG31/P07	33	112	P43/SIN3
RX0/INT6/P70	34	111	P42/SCK0
TX0/P71	35	110	P41/SOT0
RX1/INT7/P72	36	109	P40/SIN0
P73/TX1	37		
DVcc	38		
DVss	39		
PB0/PWM1P0	40		
PB1/PWM1M0	41		
PB2/PWM2P0	42		
PB3/PWM2M0	43		
PB4/PWM1P1	44		
PB5/PWM1M1	45		
PB6/PWM2P1	46		
PB7/PWM2M1	47		
PC0/PWM1P2	48		
PC1/PWM1M2	49		
PC2/PWM2P2	50		
PC3/PWM2M2	51		
DVcc	52		
DVss	53		
P97/AN31	54		
P96/AN30	55		
P95/AN29	56		
P94/AN28	57		
P93/AN27	58		
P92/AN26	59		
P91/AN25	60		
P90/AN24	61		
P87/AN23	62		
P86/AN22	63		
P85/AN21	64		
P84/AN20	65		
P83/AN19	66		
P82/AN18	67		
P81/AN17	68		
P80/AN16	69		
AVcc	70		
AVRH	71		
AVRL	72		
AVss/AVRL	72		
		108	INIT
		107	MOD0
		106	MOD1
		105	MOD2
		104	DVss
		103	DVcc
		102	PE7/PWM2M5
		101	PE6/PWM2P5
		100	PE5/PWM1M5
		99	PE4/PWM1P5
		98	PE3/PWM2M4
		97	PE2/PWM2P4
		96	PE1/PWM1M4
		95	PE0/PWM1P4
		94	PA3/PWM2M3
		93	PA2/PWM2P3
		92	PA1/PWM1M3
		91	PA0/PWM1P3
		90	DVss
		89	DVcc
		88	PF7/AN15
		87	PF6/AN14
		86	PF5/AN13
		85	PF4/AN12
		84	PF3/AN11
		83	PF2/AN10
		82	PF1/AN9
		81	PF0/AN8
		80	P67/AN7
		79	P66/AN6
		78	P65/AN5
		77	P64/AN4
		76	P63/AN3
		75	P62/AN2
		74	P61/AN1
		73	P60/AN0

(FPT-144P-M08)

## ■ PIN DESCRIPTIONS

Pin no.	Pin name	I/O circuit type*	Function
1 to 4	P24 to P27	F	General purpose I/O port pins
	SEG04 to SEG07		SEG output pin for LCDC
	A04 to A07		Bits 04 to 07 pins of external address bus
5 to 12	P30 to P37	F	General purpose I/O port pins
	SEG08 to SEG15		SEG output pins for LCDC
	A08 to A15		Bits 08 to 15 pins of external address bus
13 to 15	P10 to P12	G	General purpose I/O port pins
	SEG16 to SEG18		SEG output pins for LCDC
	D08 to D10		Bits 08 to 10 pins of external data bus
16	X0A	B	Sub clock (oscillation) input
17	X1A	B	Sub clock (oscillation) output
18	V <sub>CC</sub>	—	Power supply pins
19	V <sub>SS</sub>	—	GND pins
20	V <sub>CC</sub> 3C	—	Capacitor connection pin for internal regulator
21 to 25	P13 to P17	G	General purpose I/O port pins
	SEG19 to SEG23		SEG output pins for LCDC
	D11 to D15		Bits 11 to 15 pins of external data bus
26 to 31	P00 to P05	G	General purpose I/O port pins
	SEG24 to SEG29		SEG output pins for LCDC
	INT0 to INT5		External interrupt input pins
	D00 to D05		Bits 00 to 05 pins of external data bus
32	P06	G	General purpose I/O port pin
	SEG30		SEG output pins for LCDC
	D06		Bit 06 pin of external data bus
33	P07	G	General purpose I/O port pin
	SEG31		SEG output pin for LCDC
	ATG		External trigger input pin at using of A/D converter
	D07		Bit 07 pin of external data bus
34	P70	I	General purpose I/O port pin
	INT6		External interrupt input pin
	RX0		RX0 input pin of CAN0
35	P71	I	General purpose I/O port pin
	TX0		TX0 output pin of CAN0

(Continued)

# MB91245/S Series

Pin no.	Pin name	I/O circuit type*	Function
36	P72	I	General purpose I/O port pin
	INT7		External interrupt input pin
	RX1		RX1 input pin of CAN1
37	P73	I	General purpose I/O port pin
	TX1		TX1 output pin of CAN1
38	DV <sub>cc</sub>	—	Power supply input pins for SMC
39	DV <sub>ss</sub>	—	GND pins for SMC
40	PB0	H	General purpose I/O port pin
	PWM1P0		PWM output pin of stepping motor controller
41	PB1	H	General purpose I/O port pin
	PWM1M0		PWM output pin of stepping motor controller
42	PB2	H	General purpose I/O port pin
	PWM2P0		PWM output pin of stepping motor controller
43	PB3	H	General purpose I/O port pin
	PWM2M0		PWM output pin of stepping motor controller
44	PB4	H	General purpose I/O port pin
	PWM1P1		PWM output pin of stepping motor controller
45	PB5	H	General purpose I/O port pin
	PWM1M1		PWM output pin of stepping motor controller
46	PB6	H	General purpose I/O port pin
	PWM2P1		PWM output pin of stepping motor controller
47	PB7	H	General purpose I/O port pin
	PWM2M1		PWM output pin of stepping motor controller
48	PC0	H	General purpose I/O port pin
	PWM1P2		PWM output pin of stepping motor controller
49	PC1	H	General purpose I/O port pin
	PWM1M2		PWM output pin of stepping motor controller
50	PC2	H	General purpose I/O port pin
	PWM2P2		PWM output pin of stepping motor controller
51	PC3	H	General purpose I/O port pin
	PWM2M2		PWM output pin of stepping motor controller
52	DV <sub>cc</sub>	—	Power supply input pins for SMC
53	DV <sub>ss</sub>	—	GND pins for SMC

(Continued)

# MB91245/S Series

Pin no.	Pin name	I/O circuit type*	Function
54 to 61	P97 to P90	E	General-purpose I/O port pins : Valid when analog input is prohibited
	AN31 to AN24		Analog input pins of A/D converter : Valid when ADER register is set to analog input
62 to 69	P87 to P80	E	General-purpose I/O port pins : Valid when analog input is prohibited
	AN23 to AN16		Analog input pins of A/D converter : Valid when ADER register is set to analog input
70	AV <sub>cc</sub>	—	Analog power supply input pin for A/D converter
71	AVRH	—	Analog base voltage input pin for A/D converter
72	AV <sub>ss</sub> /AVRL	—	Analog GND/analog base low voltage input pin for A/D converter
73 to 80	P60 to P67	E	General-purpose I/O port pins : Valid when analog input is prohibited
	AN0 to AN7		Analog input pins of A/D converter : Valid when ADER register is set to analog input
81 to 88	PF0 to PF7	E	General-purpose I/O port pins : Valid when analog input is prohibited
	AN8 to AN15		Analog input pins of A/D converter : Valid when ADER register is set to analog input
89	DV <sub>cc</sub>	—	Power supply input pins for SMC
90	DV <sub>ss</sub>	—	GND pins for SMC
91	PA0	H	General purpose I/O port pin
	PWM1P3		PWM output pin of stepping motor controller
92	PA1	H	General purpose I/O port pin
	PWM1M3		PWM output pin of stepping motor controller
93	PA2	H	General purpose I/O port pin
	PWM2P3		PWM output pin of stepping motor controller
94	PA3	H	General purpose I/O port pin
	PWM2M3		PWM output pin of stepping motor controller
95	PE0	H	General purpose I/O port pin
	PWM1P4		PWM output pin of stepping motor controller
96	PE1	H	General purpose I/O port pin
	PWM1M4		PWM output pin of stepping motor controller
97	PE2	H	General purpose I/O port pin
	PWM2P4		PWM output pin of stepping motor controller
98	PE3	H	General purpose I/O port pin
	PWM2M4		PWM output pin of stepping motor controller

(Continued)

# MB91245/S Series

Pin no.	Pin name	I/O circuit type*	Function
99	PE4	H	General purpose I/O port pin
	PWM1P5		PWM output pin of stepping motor controller
100	PE5	H	General purpose I/O port pin
	PWM1M5		PWM output pin of stepping motor controller
101	PE6	H	General purpose I/O port pin
	PWM2P5		PWM output pin of stepping motor controller
102	PE7	H	General purpose I/O port pin
	PWM2M5		PWM output pin of stepping motor controller
103	DV <sub>cc</sub>	—	Power supply input pins for SMC
104	DV <sub>ss</sub>	—	GND pins for SMC
105	MOD2	D	Mode pin 2 : Used to set basic operating mode and required to be connected to V <sub>cc</sub> or V <sub>ss</sub>
106	MOD1	D	Mode pin 1 : Used to set basic operating mode and required to be connected to V <sub>cc</sub> or V <sub>ss</sub>
107	MOD0	D	Mode pin 0 : Used to set basic operating mode and required to be connected to V <sub>cc</sub> or V <sub>ss</sub>
108	$\overline{\text{INIT}}$	C	External reset input pin
109	P40	I	General-purpose I/O port pin : Valid when UART0 data input is prohibited
	SIN0		UART0 serial data input pin, requiring output by ports to be stopped while UART0 is performing input operation, except when executed intentionally, as this input is always in use
110	P41	I	General-purpose I/O port pin : Valid when UART0 data output is prohibited
	SOT0		UART0 serial data output pin : Valid when UART0 data output is permitted
111	P42	I	General-purpose I/O port pin : Valid when clock output of UART0 is prohibited
	SCK0		UART0 clock input and output pin for serial communication : Valid when clock output of UART0 is permitted
112	P43	I	General-purpose I/O port pin : Valid when LIN-UART0 data input is prohibited
	SIN3		LIN-UART0 serial data input pin, requiring output by ports to be stopped while LIN-UART0 is performing input operation, except when executed intentionally, as this input is always in use
113	P44	I	General-purpose I/O port pin : Valid when LIN-UART0 data output is prohibited
	SOT3		LIN-UART0 serial data output pin : Valid when data output of LIN-UART0 is permitted

(Continued)



# MB91245/S Series

Pin no.	Pin name	I/O circuit type*	Function
114	P45	I	General-purpose I/O port pin : Valid when clock output of LIN-UART0 is prohibited
	SCK3		LIN-UART0 clock input and output pin for serial communication : Valid when clock output of LIN-UART0 is permitted
115	P50	I	General-purpose I/O port pin
	SIN4		Serial data input pin of LIN-UART1 : LIN-UART1, requiring output by ports to be stopped while LIN-UART1 is performing input operation, except when executed intentionally, as this input is always in use
	CK0		External clock input pin of free-run timer 0
	$\overline{CS0}$		Output pin of chip select 0 : Valid when external bus mode is selected
116	P51	I	General-purpose I/O port pin
	SOT4		LIN-UART1 serial data output pin : Valid when data output of LIN-UART1 is permitted
	$\overline{CS1}$		Output pin of chip select 1 : Valid when output of chip select 1 is permitted
117	P52	I	General-purpose I/O port pin
	SCK4		LIN-UART1 clock input and output pin for serial communication : Valid when clock output of LIN-UART1 is permitted
	$\overline{CS2}$		Output pin of chip select 2 : Valid when output of chip select 2 is permitted
118	P53	I	General-purpose I/O port pin
	SIN5		Serial data input pin of LIN-UART2 : LIN-UART2, requiring output by ports to be stopped while LIN-UART2 is performing input operation, except when executed intentionally, as this input is always in use
	CK1		External clock input pin of free-run timer 1
	$\overline{CS3}$		Output of chip select 3 : Valid when output of chip select 3 is permitted
119	P54	I	General-purpose I/O port pin
	SOT5		Serial data output pin of LIN-UART2 : Valid when data output of LIN-UART2 is permitted
	$\overline{RD}$		Read strobe output pin of external bus : Valid when external bus mode is selected
120	P55	I	General-purpose I/O port pin
	SCK5		LIN-UART2 clock input and output pin for serial communication : Valid when clock output of LIN-UART2 is permitted
	$\overline{WR0}$		Write strobe output pin of external bus : Valid when $\overline{WR0}$ output is permitted in external bus mode

(Continued)

# MB91245/S Series

Pin no.	Pin name	I/O circuit type*	Function
121	P56	I	General-purpose I/O port pin
	OUT0		Output compare output pin
	$\overline{WR1}$		Write strobe output pin of external bus : Valid when $\overline{WR1}$ output is permitted in external bus mode
122	P57	J	General-purpose I/O port pin
	OUT1		Output compare output pin
	RDY		External ready input pin : Valid when external ready input is permitted
123	P46	I	General-purpose I/O port pin
	SGA		Sound generator pin
	$\overline{AS}$		External address strobe output pin : Valid when address strobe output is permitted
124	P47	I	General-purpose I/O port pin
	SGO		Sound generator pin
	SYSCCLK		System clock output pin : Valid when system clock output is permitted and outputs the same clock as the operating frequency of external bus (Output is stopped in STOP mode)
125	PG0	I	General-purpose I/O port pin
	PPG0		Output of PPG timer 0 : Valid when output of PPG timer 0 is permitted
126	V <sub>cc</sub>	—	Power supply pins
127	V <sub>ss</sub>	—	GND pins
128	X1	A	Main clock (oscillation) output pin
129	X0	A	Main clock (oscillation) input pin
130	PG1	I	General-purpose I/O port pin
	TOT0		Output pin for reload timer
	PPG2		Output pin of PPG timer 2 : Valid when output of PPG timer 2 is permitted
131	PG2	I	General-purpose I/O port pin
	TOT1		Output pin for reload timer
	PPG4		Output pin of PPG timer 4 : Valid when output of PPG timer 4 is permitted
132	PG3	I	General-purpose I/O port pin
	TOT2		Output pin for reload timer
	PPG6		Output pin of PPG timer 6 : Valid when output of PPG timer 6 is permitted

(Continued)

(Continued)

Pin no.	Pin name	I/O circuit type*	Function
133	PD0	K	General-purpose I/O port pin
	TIN0		Event input pin for reload timer
	IN0		Trigger input pin of input capture 0 : This sets input capture to trigger input and is enabled when input port is set up. When set as input capture input, it requires output by ports to be stopped, except when executed intentionally, as this input is always used.
	PWC0		Input pin of pulse width counter 0 of PWC0 : Valid when input of pulse width counter 0 of PWC0 is permitted
134	PD1	K	General-purpose I/O port pin
	TIN1		Event input pin for reload timer
	IN1		Trigger input pin of input capture 1 : This sets input capture to trigger input and is enabled when input port is set up. When set as input capture input, it requires output by ports to be stopped, except when executed intentionally, as this input is always used.
135	PD2	K	General-purpose I/O port pin
	TIN2		Event input pin for reload timer
	IN2		Trigger input pin of input capture 2 : This sets input capture to trigger input and is enabled when input port is set up. When set as input capture input, it requires output by ports to be stopped, except when executed intentionally, as this input is always used.
136	PD3	K	General-purpose I/O port pin
	IN3		Trigger input pin of input capture 3 : This sets input capture to trigger input and is enabled when input port is set up. When set as input capture input, it requires output by ports to be stopped, except when executed intentionally, as this input is always used.
137 to 140	PD4 to PD7	F	General-purpose I/O port pin
	COM0 to COM3		Output pin of COM0 to COM3 of LCDC
	PPG1, PPG3, PPG5, PPG7		Output pin of PPG timer 1, 3, 5 and 7 : Valid when output of PPG timer 1, 3, 5 and 7 is permitted
141 to 144	P20 to P23	F	General purpose I/O port pins
	SEG00 to SEG03		SEG output pins for LCDC
	A00 to A03		Bits 00 to 03 pins of external address bus

\* : For information about the I/O circuit type, refer to “■ I/O CIRCUIT TYPE”.

# MB91245/S Series

## ■ I/O CIRCUIT TYPE

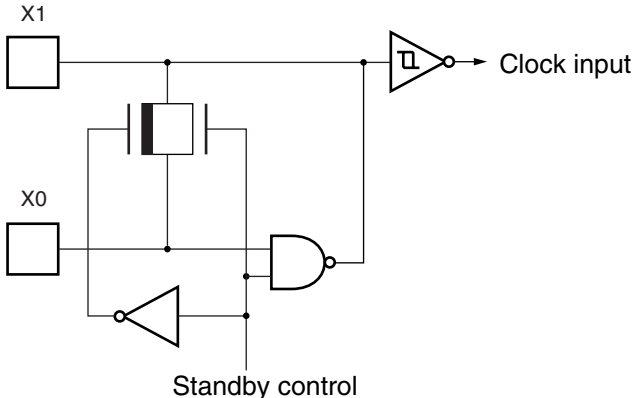
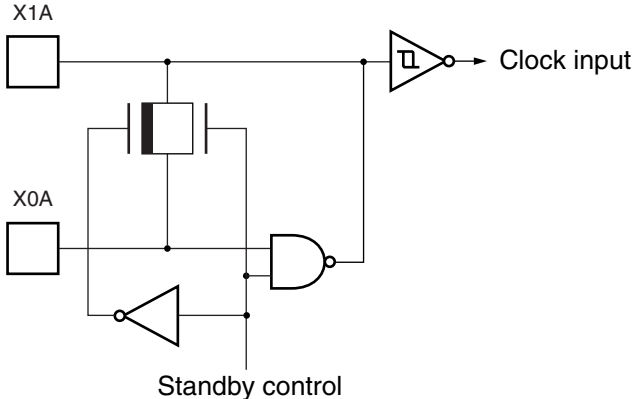
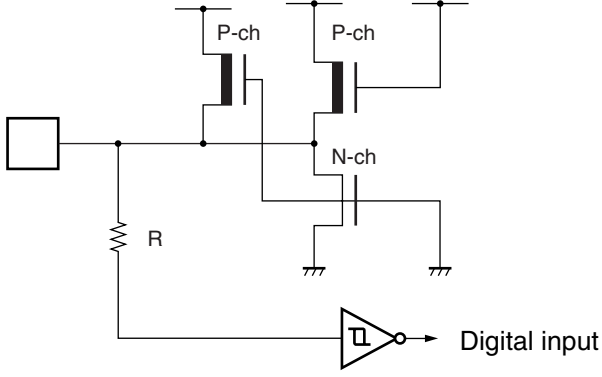
Group	Circuit Type	Remarks
A		<p>For high speed (source oscillation of main clock)</p> <ul style="list-style-type: none"> <li>• Oscillation circuit</li> <li>• Feedback resistance X0 : approx. 1 MΩ</li> </ul>
B		<p>For low speed (source oscillation of sub clock)</p> <ul style="list-style-type: none"> <li>• Oscillation circuit</li> <li>• Feedback resistance X0A : approx. 7 MΩ</li> </ul>
C		<ul style="list-style-type: none"> <li>• CMOS hysteresis input</li> <li>• Pull-up resistor provided</li> <li>• No standby control</li> </ul>

(Continued)

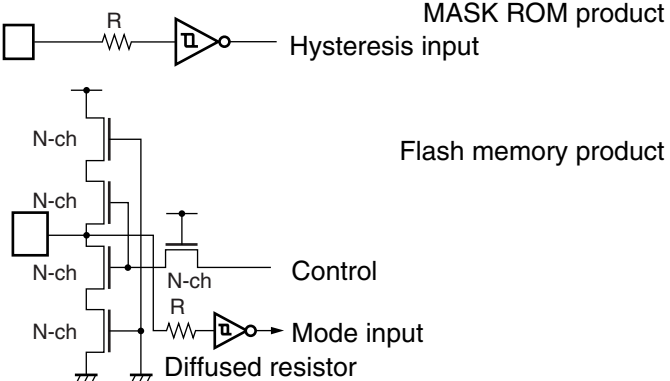
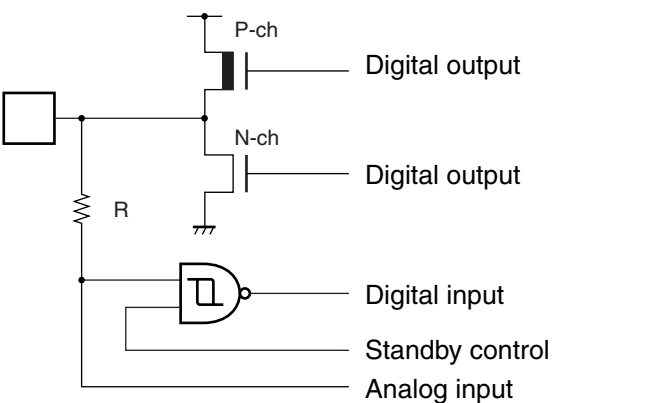
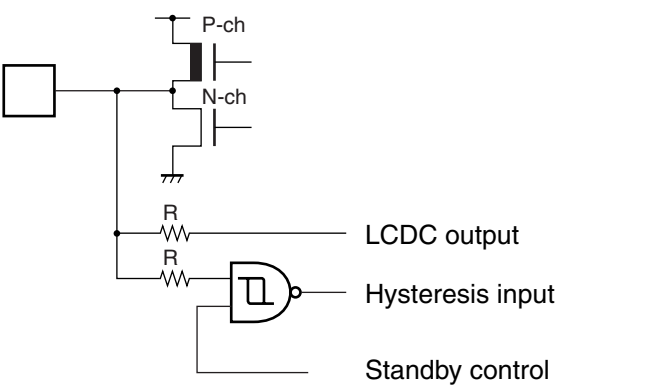
Group	Circuit Type	Remarks
D	 <p>MASK ROM product Hysteresis input</p> <p>Flash memory product Control Mode input Diffused resistor</p>	<ul style="list-style-type: none"> <li>• MASK ROM product Hysteresis input Pull-down resistor provided only for MOD2 &amp; MOD1</li> <li>• Flash memory product Hysteresis input High-voltage control for Flash test provided</li> </ul>
E	 <p>Digital output Digital output Digital input Standby control Analog input</p>	<ul style="list-style-type: none"> <li>• CMOS output (4 mA)</li> <li>• Hysteresis (Automotive level) input (Standby control provided)</li> <li>• Analog input (Analog input is valid when the corresponding ADER bit is set to 1.)</li> </ul>
F	 <p>LCDC output Hysteresis input Standby control</p>	<ul style="list-style-type: none"> <li>• CMOS output (4 mA)</li> <li>• LCDC output</li> <li>• Hysteresis (Automotive level) input (Standby control provided)</li> </ul>

(Continued)

# MB91245/S Series

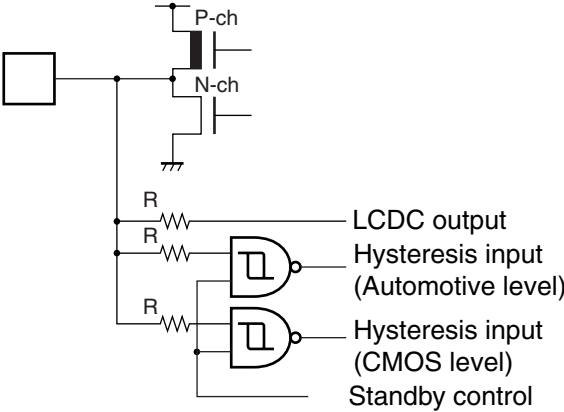
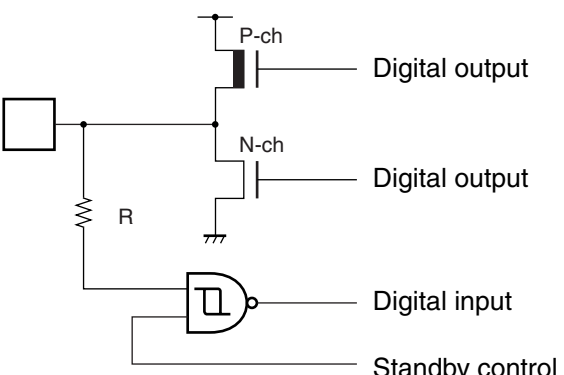
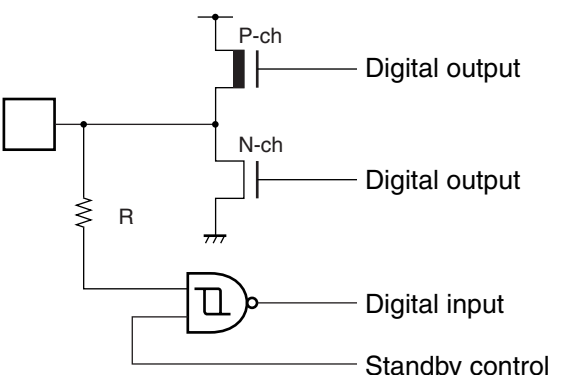
Group	Circuit Type	Remarks
G	 <p>           P-ch            N-ch            R            R            R            R            LCD output            Hysteresis input (Automotive level)            Hysteresis input (CMOS level)            Standby control         </p>	<ul style="list-style-type: none"> <li>• CMOS output (4 mA)</li> <li>• LCD output</li> <li>• Hysteresis (Automotive level) input (Standby control provided)</li> <li>• Hysteresis (CMOS level) input (Standby control provided)</li> </ul>
H	 <p>           P-ch            N-ch            R            Digital output            Digital output            Digital input            Standby control         </p>	<ul style="list-style-type: none"> <li>• CMOS output</li> <li>• High current output for PWM (30 mA)</li> <li>• Hysteresis (Automotive level) input (Standby control provided)</li> </ul>
I	 <p>           P-ch            N-ch            R            Digital output            Digital output            Digital input            Standby control         </p>	<ul style="list-style-type: none"> <li>• CMOS output (4 mA)</li> <li>• Hysteresis (Automotive level) input (Standby control provided)</li> </ul>

(Continued)

(Continued)

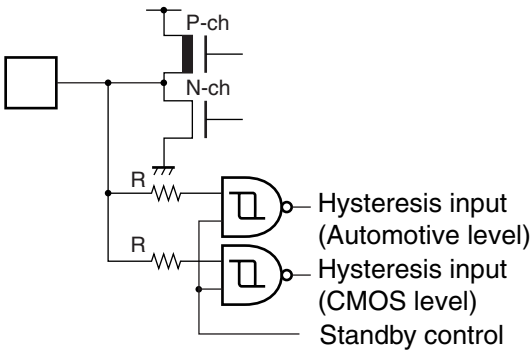
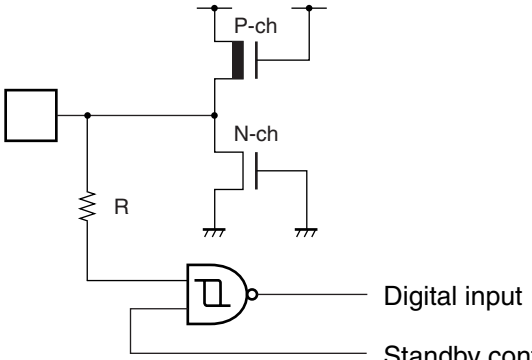
Group	Circuit Type	Remarks
J	 <p>The diagram shows a CMOS output stage consisting of a P-channel MOSFET (P-ch) and an N-channel MOSFET (N-ch). The gates of both MOSFETs are connected to a common node. This node is also connected to a square-wave input signal. Two resistors, labeled 'R', are connected between the common node and the gates of the P-ch and N-ch MOSFETs. The gates are also connected to two hysteresis input blocks, each represented by a square with a 'U' inside. The first hysteresis input is labeled 'Hysteresis input (Automotive level)' and the second is labeled 'Hysteresis input (CMOS level)'. A 'Standby control' input is also shown connected to the gates of the MOSFETs.</p>	<ul style="list-style-type: none"> <li>• CMOS output (4 mA)</li> <li>• Hysteresis (Automotive level) input (Standby control provided)</li> <li>• Hysteresis (CMOS level) input (Standby control provided)</li> </ul>
K	 <p>The diagram shows a CMOS output stage with a P-channel MOSFET (P-ch) and an N-channel MOSFET (N-ch). The gates of both MOSFETs are connected to a common node. This node is connected to a square-wave input signal and a resistor labeled 'R'. The gates are also connected to a single hysteresis input block, represented by a square with a 'U' inside, labeled 'Digital input'. A 'Standby control' input is also shown connected to the gates of the MOSFETs.</p>	<ul style="list-style-type: none"> <li>• Hysteresis (Automotive level) input (Standby control provided)</li> </ul>

# MB91245/S Series

## ■ HANDLING DEVICES

### • Preventing Latch-up

Latch-up may occur in a CMOS IC, if a voltage greater than  $V_{CC}$  pin or less than  $V_{SS}$  pin is applied to input and output pin, or if an above-rating voltage is applied between  $V_{CC}$  and  $V_{SS}$ . When latch-up occurs, it may significantly increase the power supply current, and may cause thermal destruction of an element. When you use a CMOS IC, be very careful not to exceed the maximum rating.

### • Treatment of Unused Input Pins

Do not leave an unused input pin open, since it may cause a malfunction. Handle by performing a pull-up or pull-down with a resistance of  $2\text{ k}\Omega$  or more. An unused I/O pin should be set to the output status and left open. When set to the input status, it should be handled in the same way as an input pin.

### • About power supply pins

If there are multiple  $V_{CC}$  and  $V_{SS}$  pins, from the point of view of device design pins to be of the same potential are connected inside the device to prevent such malfunctioning as latch-up. However, you must connect all the pins to external power supply and a ground line to lower the electro-magnetic emission level, to prevent abnormal operation of strobe signals caused by the rise in the ground level, and to conform to the total output current rating. Moreover, connect the current supply source with the  $V_{CC}$  and  $V_{SS}$  pins of this device at the low impedance.

Furthermore, it is also advisable to connect a ceramic bypass capacitor of approximately  $0.1\ \mu\text{F}$  between  $V_{CC}$  and  $V_{SS}$  near this device.

This device incorporates a regulator. When using the device with 5V power supply, apply that power supply to the  $V_{CC}$  pin and always connect a  $1\ \mu\text{F}$  or greater capacitor to the  $V_{CC3C}$  for the regulator.

### Example of power supply connection

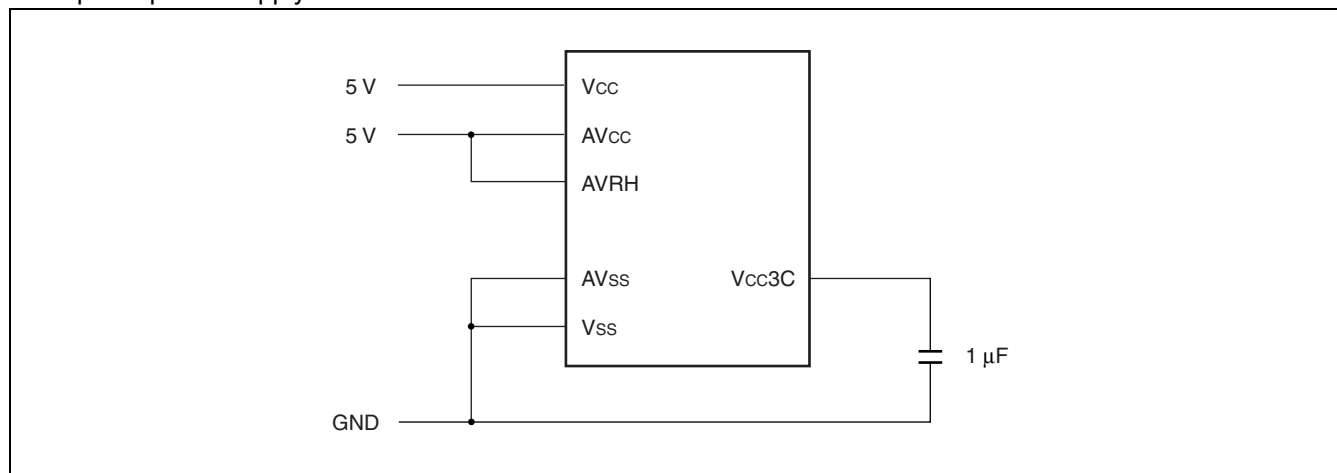



- Crystal oscillator circuit

Noise near the X0/X1 pins and X0A/X1A pins may cause the device to malfunction. Design the PC board such that X0/X1 pins, X0A/X1A pins, the crystal oscillator (or ceramic oscillator), and the bypass capacitor to the ground are placed as near one another as possible. When routing the X0 and X1 signals, they should be shielded for use on the board. Caution must be taken especially when using a pin next to the X0.

It is strongly recommended to design the PC board artwork with the X0, X1, X0A and X1A pins surrounded by ground plane because stable operation can be expected with such a layout.

In addition, a sub clock is required even when a dual clock product is used as a single clock product.

When using MB91F248S/248S/247S, connect the X0A pin to GND and leave the X1A pin open.

Please ask the crystal maker to evaluate the oscillational characteristics of the crystal and this device.

- Mode pins (MOD0 to MOD2)

These pins should be connected directly to  $V_{CC}$  or  $V_{SS}$  pins. To prevent the device erroneously switching to test mode due to noise, design the PC board such that the distance between the mode pins and  $V_{CC}$  or  $V_{SS}$  pins is as short as possible and the connection impedance is low.

- Operation at start-up

Always use the  $\overline{INIT}$  pin to perform a setting initialization reset (INIT) after power-on. Immediately after power-on, hold the low level input to the  $\overline{INIT}$  pin for the stabilization wait time required for the oscillator circuit, to take the oscillation stabilization wait time for the oscillator circuit.

For INIT via the  $\overline{INIT}$  pin, the oscillation stabilization wait time setting is initialized to the minimum value.

- Source oscillation input upon power-on

When power-on, always input the clock for the duration of the oscillation stabilization delay time.

- Treatment of power supply pins on A/D converter

Connect to ensure " $AV_{CC} = AVRH = V_{CC}$  and  $AV_{SS} = V_{SS}$ " even if the A/D converter is not in use.

- Power-on sequence for power supply analog input of A/D converter

Always supply power to the A/D converter ( $AV_{CC}$  and  $AVRH$ ) and apply analog input (AN0 to AN 31) after turning on the digital power supply ( $V_{CC}$ ). Also, turn off the power supply for the A/D converter and analog input before turning off the digital power supply ( $V_{CC}$ ). In so doing, the power supply must be turn on and off so that  $AVRH$  does not exceed  $AV_{CC}$ . Even when using a pin shared with analog input as an input port, ensure that the input voltage does not exceed  $AV_{CC}$  (There is no problem in turning on or off the analog and digital power supplies at the same time).

- Handling of power supply for high-current output buffer pin ( $DV_{CC}$ ,  $DV_{SS}$ )

Always apply power to high-current output buffer pins ( $DV_{CC}$ ) after turning on the digital power supply ( $V_{CC}$ ). In addition, turn off the power supply for the high-current output buffer pins before turning off the digital power supply ( $V_{CC}$ ).

Apply the same power as for high-current output buffer pins even when using such pins as general-purpose ports. (There is no problem in turning on or off the power supply for the high-current output buffer pins and the digital power supply at the same time.)

Always use the GND pin ( $DV_{SS}$ ) for the high-current output buffer pin at the same potential as the digital GND ( $V_{SS}$ ).

# MB91245/S Series

- About switching from main clock mode to sub clock mode or stop mode

Always stop the main clock after switching the main clock mode to the sub clock mode or stop mode. Also secure the oscillation stabilization wait time when returning from the sub clock mode or stop mode to the main clock mode.

- About Flash write

Note that Flash write is not possible in the sub mode.

## ■ BLOCK DIAGRAM

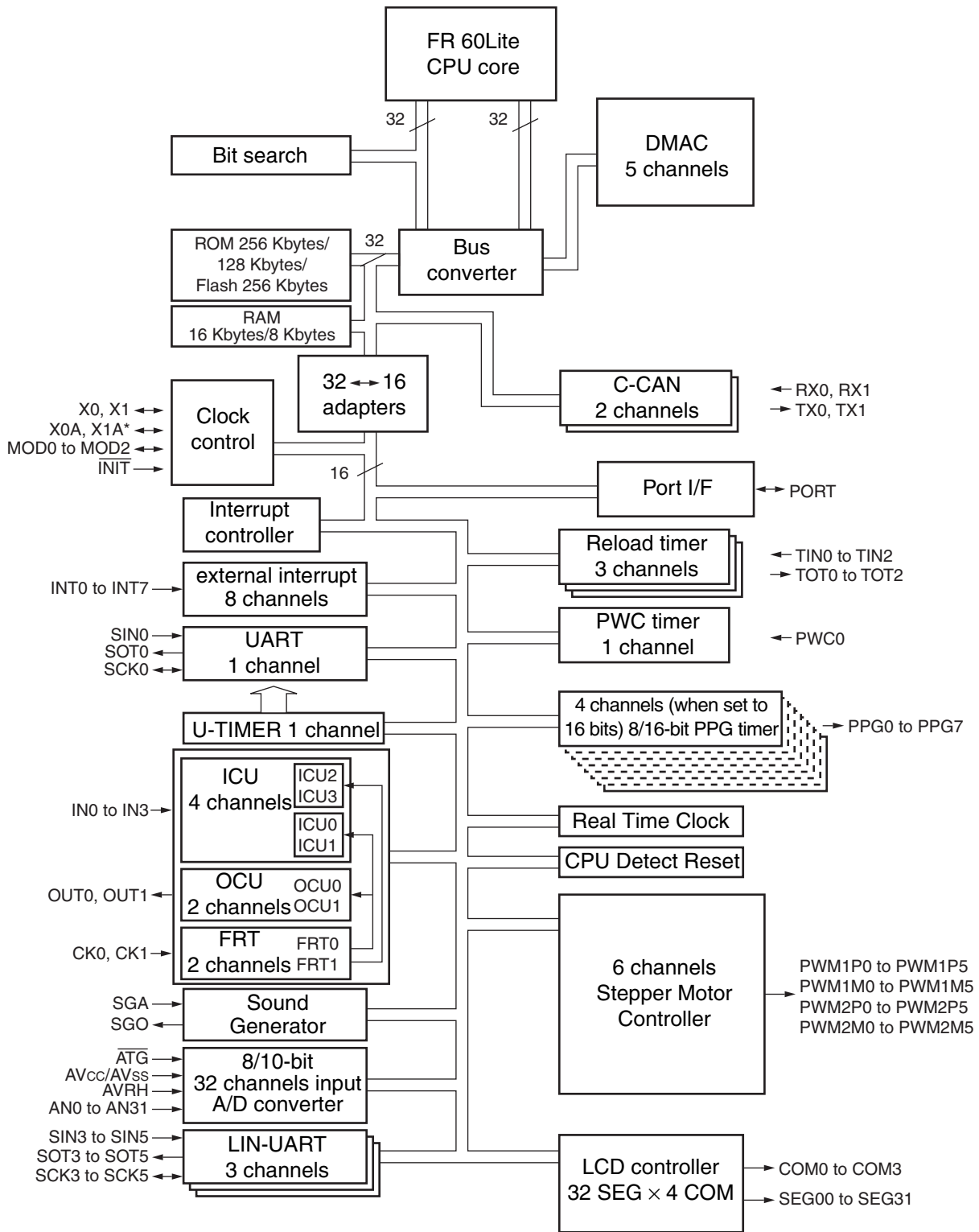

\* : The sub clock is not supported in single clock products.

# MB91245/S Series

## ■ MEMORY SPACE

- Memory space

The FR family has of 4 Gbytes logical address space ( $2^{32}$  addresses) linearly accessible to the CPU space.

- Direct addressing area

The following address space areas are used as I/O areas.

These areas are called direct addressing areas, in which the address of an operand can be specified directly during on instruction.

The direct area varies depending on the size of data to be accessed as follows.

→ Byte data access : 000<sub>H</sub> to 0FF<sub>H</sub>

→ Halfword data access : 000<sub>H</sub> to 1FF<sub>H</sub>

→ Word data access : 000<sub>H</sub> to 3FF<sub>H</sub>

## ■ MEMORY MAP

### MB91V245A

	Single chip mode	Internal ROM external bus mode	External ROM external bus mode	
0000 0000H .....	I/O	I/O	I/O	Direct addressing area
0000 0400H .....	I/O	I/O	I/O	
0001 0000H .....	Access prohibited	Access prohibited	Access prohibited	Refer to "■ I/O MAP".
0002 0000H .....	I/O (C-CAN)	I/O (C-CAN)	I/O (C-CAN)	
0002 01B4H .....	Access prohibited	Access prohibited	Access prohibited	
0003 8000H .....	Internal RAM 32 KB	Internal RAM 32 KB	Internal RAM 32 KB	
0004 0000H .....			Access prohibited	
0005 0000H .....	Access prohibited	Access prohibited		
0008 0000H .....	Emulation SRAM area	Emulation SRAM area	External area	
0010 0000H .....	Access prohibited	External area		
FFFF FFFFH .....				

# MB91245/S Series

## MB91F248/S

	Single chip mode	Internal ROM external bus mode	External ROM external bus mode		
0000 0000H	I/O	I/O	I/O	Direct addressing area	
0000 0400H	I/O	I/O	I/O		
0001 0000H	Access prohibited	Access prohibited	Access prohibited	Refer to "■ I/O MAP".	
0002 0000H	I/O (C-CAN)	I/O (C-CAN)	I/O (C-CAN)		
0002 01B4H	Access prohibited	Access prohibited	Access prohibited		
0003 C000H	Internal RAM 16 KB	Internal RAM 16 KB	Internal RAM 16 KB		
0004 0000H	Access prohibited	Access prohibited	Access prohibited		
0005 0000H	Access prohibited	Access prohibited	External area		
000C 0000H	Flash memory area 256 Kbytes	Flash memory area 256 Kbytes			
0010 0000H	Access prohibited	External area			
FFFF FFFFH					

## MB91248/S

	Single chip mode	Internal ROM external bus mode	External ROM external bus mode		
0000 0000H	I/O	I/O	I/O	Direct addressing area	
0000 0400H	I/O	I/O	I/O		
0001 0000H	Access prohibited	Access prohibited	Access prohibited	Refer to "■ I/O MAP".	
0002 0000H	I/O (C-CAN)	I/O (C-CAN)	I/O (C-CAN)		
0002 01B4H	Access prohibited	Access prohibited	Access prohibited		
0003 C000H	Internal RAM 16 KB	Internal RAM 16 KB	Internal RAM 16 KB		
0004 0000H	Access prohibited	Access prohibited	Access prohibited		
0005 0000H	Access prohibited	Access prohibited	External area		
000C 0000H	MASK ROM area 256 Kbytes	MASK ROM area 256 Kbytes			
0010 0000H	Access prohibited	External area			
FFFF FFFFH					

Note : Each mode is set depending on the mode vector fetch after  $\overline{INIT}$  is negated (For mode settings, refer to "■ MODE SETTINGS").

## MB91247/S

	Single chip mode	Internal ROM external bus mode	External ROM external bus mode		
0000 0000H	I/O	I/O	I/O	Direct addressing area	
0000 0400H	I/O	I/O	I/O		
0001 0000H	Access prohibited	Access prohibited	Access prohibited	Refer to "■ I/O MAP".	
0002 0000H	I/O (C-CAN)	I/O (C-CAN)	I/O (C-CAN)		
0002 01B4H	Access prohibited	Access prohibited	Access prohibited		
0003 E000H	Internal RAM 8 KB	Internal RAM 8 KB	Internal RAM 8 KB		
0004 0000H	Access prohibited	Access prohibited	Access prohibited		
0005 0000H	Access prohibited	Access prohibited	External area		
000E 0000H	MASK ROM area 128 Kbytes	MASK ROM area 128 Kbytes			
0010 0000H	Access prohibited	External area			
FFFF FFFFH					

Note : Each mode is set depending on the mode vector fetch after  $\overline{\text{INIT}}$  is negated (For mode settings, refer to "■ MODE SETTINGS").

# MB91245/S Series

## MODE SETTINGS

The FR family, sets the operation mode using mode pins (MOD2 to MOD0) and mode data.

- Mode pins

The mode pins (MOD2 to MOD0) specify how the mode vector fetch and reset vector fetch is performed.

Other settings than these in the table are prohibited.

Mode pin			Mode name	Reset vector access area
MOD2	MOD1	MOD0		
0	0	0	Internal ROM mode vector	Internal
0	0	1	External ROM mode vector	External

- Mode data

Data written to the internal mode register (MODR) by mode vector fetch is called mode data.

After an operating mode has been set in the mode register the device operates in that operating mode.

The mode data is set by all reset sources. User programs cannot set data to the mode register.

### Detailed description of mode data

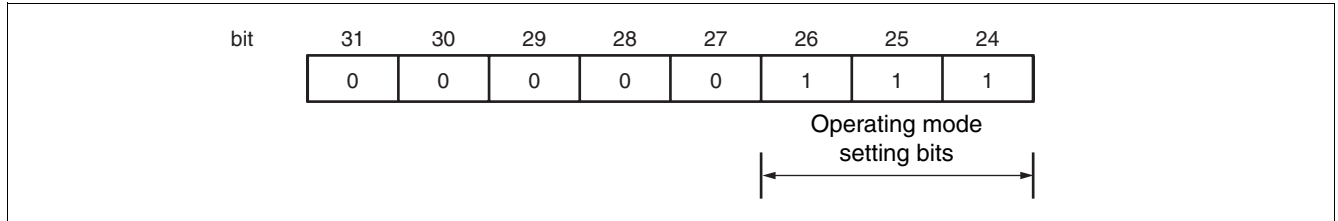

Bit 31 to bit 24 are reserved.

Always set the value to “00000111<sub>B</sub>”. Normal operation is not guaranteed when a value other than “00000111<sub>B</sub>” is set.

Note : Mode data set in the mode vector must be placed as byte data at 0x000FFFF8<sub>H</sub>.

Place the data in the most significant byte from bit 31 to bit 24 as the FR family uses the big endian system for byte endian.

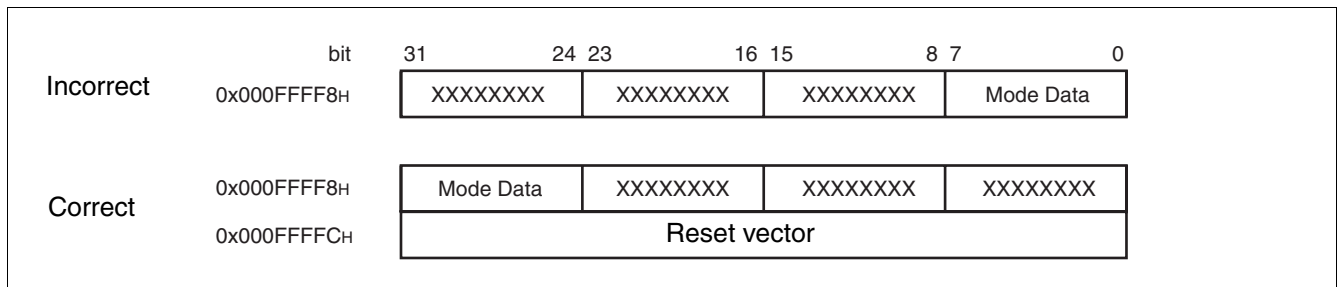



## ■ I/O MAP

The following table shows the correspondence between the memory space area and each register of the peripheral resource.

[How to read the map]

Address	Register				Block
	+ 0	+ 1	+ 2	+ 3	
000000 <sub>H</sub>	PDR0 [R/W] B ↑XXXXXXXX↑	PDR1 [R/W] B XXXXXXXX	PDR2 [R/W] B XXXXXXXX	PDR3 [R/W] B XXXXXXXX	T-unit Port data register

Read/Write attribute, Access unit  
(B : byte, H : halfword, W : word)

Initial value after reset

Register name (First-column register at address 4n; second-column register at 4n + 1, etc.)

Location of left-most register (When using word access, the register in column 1 is in the MSB side of the data.)

Note :

Initial values of register bits are represented as follows :

“ 1 ” : Initial value “1”

“ 0 ” : Initial value “0”

“ X ” : Initial value “undefined”

“ - ” : No physical register present at this location

Access by any undescribed data access attribute is prohibited.

# MB91245/S Series

Address	Register				Block
	+ 0	+ 1	+ 2	+ 3	
00000000 <sub>H</sub>	PDR0 [R/W] B, H XXXXXXXX	PDR1 [R/W] B, H XXXXXXXX	PDR2 [R/W] B, H 00000000	PDR3 [R/W] B, H XXXX0000	Port Data Register
00000004 <sub>H</sub>	PDR4 [R/W] B, H XXXXXXXX	PDR5 [R/W] B, H XXXXXXXX	PDR6 [R/W] B, H XXXXXXXX	PDR7 [R/W] B, H ----XXXX	
00000008 <sub>H</sub>	PDR8 [R/W] B, H XXXXXXXX	PDR9 [R/W] B, H XXXXXXXX	PDRA [R/W] B, H ----XXXX	PDRB [R/W] B, H XXXXXXXX	
0000000C <sub>H</sub>	PDRC [R/W] B, H ----XXXX	PDRD [R/W] B, H 0000XXXX	PDRE [R/W] B, H XXXXXXXX	PDRF [R/W] B, H XXXXXXXX	
00000010 <sub>H</sub>	PDRG [R/W] B, H ----XXXX	—			
00000014 <sub>H</sub> to 0000003C <sub>H</sub>	—				Reserved
00000040 <sub>H</sub>	EIRR0 [R/W] B, H, W 00000000	ENIR0 [R/W] B, H, W 00000000	ELVR0 [R/W] B, H, W 00000000 00000000		External Interrupt Control (INT0 to INT7)
00000044 <sub>H</sub>	DICR [R/W] B, H, W -----0	HRCL [R/W] B 0--11111	—		Delay Interrupt Module
00000048 <sub>H</sub>	TMRLR0 [W] H, W XXXXXXXX XXXXXXXX		TMR0 [R] H, W XXXXXXXX XXXXXXXX		Reload Timer 0
0000004C <sub>H</sub>	—	00001000	TMCSR0 [R/W] B, H, W ----0000 00000000		
00000050 <sub>H</sub>	TMRLR1 [W] H, W XXXXXXXX XXXXXXXX		TMR1 [R] H, W XXXXXXXX XXXXXXXX		Reload Timer 1
00000054 <sub>H</sub>	—		TMCSR1 [R/W] B, H, W ----0000 00000000		
00000058 <sub>H</sub>	TMRLR2 [W] H, W XXXXXXXX XXXXXXXX		TMR2 [R] H, W XXXXXXXX XXXXXXXX		Reload Timer 2
0000005C <sub>H</sub>	—		TMCSR2 [R/W] B, H, W ----0000 00000000		
00000060 <sub>H</sub>	SSR [R/W] B, H, W 00001000	SIDR [R/W] B, H, W XXXXXXXX	SCR [R/W] B, H, W 00000100	SMR [R/W] B, H, W 00--0-0-	UART0
00000064 <sub>H</sub>	UTIM [R] H (UTIMR [W] H) 00000000 00000000		DRCL [W] B -----	UTIMC [R/W] B 0--00001	U-TIMER0
00000068 <sub>H</sub> to 0000008C <sub>H</sub>	—				Reserved
00000090 <sub>H</sub>	—	SGDBL [R/W] B -----0	SGCR [R/W] B, H, W 0-----00 000--000		Sound Generator
00000094 <sub>H</sub>	SGAR [R/W] B, H, W 00000000	SGFR [R/W] B, H, W XXXXXXXX	SGTR [R/W] B, H, W XXXXXXXX	SGDR [R/W] B, H, W XXXXXXXX	

(Continued)

# MB91245/S Series

Address	Register				Block
	+ 0	+ 1	+ 2	+ 3	
00000098 <sub>H</sub>	LCDCMR [R/W] B, H, W ----0000	—	LCR0 [R/W] B, H, W 00010000	LCR1 [R/W] B, H, W 00000000	LCD Controller Driver
0000009C <sub>H</sub>	VRAM0 [R/W] B, H, W XXXXXXXX	VRAM1 [R/W] B, H, W XXXXXXXX	VRAM2 [R/W] B, H, W XXXXXXXX	VRAM3 [R/W] B, H, W XXXXXXXX	
000000A0 <sub>H</sub>	VRAM4 [R/W] B, H, W XXXXXXXX	VRAM5 [R/W] B, H, W XXXXXXXX	VRAM6 [R/W] B, H, W XXXXXXXX	VRAM7 [R/W] B, H, W XXXXXXXX	
000000A4 <sub>H</sub>	VRAM8 [R/W] B, H, W XXXXXXXX	VRAM9 [R/W] B, H, W XXXXXXXX	VRAM10 [R/W] B, H, W XXXXXXXX	VRAM11 [R/W] B, H, W XXXXXXXX	
000000A8 <sub>H</sub>	VRAM12 [R/W] B, H, W XXXXXXXX	VRAM13 [R/W] B, H, W XXXXXXXX	VRAM14 [R/W] B, H, W XXXXXXXX	VRAM15 [R/W] B, H, W XXXXXXXX	
000000A8 <sub>H</sub> to 000000AF <sub>H</sub>	—				Reserved
000000B0 <sub>H</sub>	SCR3 [R/W] B, H, W 00000000	SMR3 [R/W] B, H, W 00000000	SSR3 [R/W] B, H, W 00001000	RDR3/TDR3 [R/W] B, H, W -----	LIN-UART0
000000B4 <sub>H</sub>	ESCR3 [R/W] B, H, W 00000X00	ECCR3 [R/W] B, H, W 000000XX	BGR13 [R/W] B, H, W XXXXXXXX	BGR03 [R/W] B, H, W XXXXXXXX	
000000B8 <sub>H</sub>	SCR4 [R/W] B, H, W 00000000	SMR4 [R/W] B, H, W 00000000	SSR4 [R/W] B, H, W 00001000	RDR4/TDR4 [R/W] B, H, W -----	LIN-UART1
000000BC <sub>H</sub>	ESCR4 [R/W] B, H, W 00000X00	ECCR4 [R/W] B, H, W 000000XX	BGR14 [R/W] B, H, W XXXXXXXX	BGR04 [R/W] B, H, W XXXXXXXX	
000000C0 <sub>H</sub>	SCR5 [R/W] B, H, W 00000000	SMR5 [R/W] B, H, W 00000000	SSR5 [R/W] B, H, W 00001000	RDR5/TDR5 [R/W] B, H, W -----	LIN-UART2
000000C4 <sub>H</sub>	ESCR5 [R/W] B, H, W 00000X00	ECCR5 [R/W] B, H, W 000000XX	BGR15 [R/W] B, H, W XXXXXXXX	BGR05 [R/W] B, H, W XXXXXXXX	
000000C8 <sub>H</sub> to 000000D0 <sub>H</sub>	—				Reserved
000000D4 <sub>H</sub>	TCDT0 [R/W] H, W 00000000 00000000		—	TCCS0 [R/W] B, H, W 00000000	16-bit Free Run Timer0
000000D8 <sub>H</sub>	TCDT1 [R/W] H, W 00000000 00000000		—	TCCS1 [R/W] B, H, W 00000000	16-bit Free Run Timer1

(Continued)

# MB91245/S Series

Address	Register				Block
	+ 0	+ 1	+ 2	+ 3	
000000DC <sub>H</sub> to 000000E0 <sub>H</sub>	—				Reserved
000000E4 <sub>H</sub>	IPCP1 [R] H, W XXXXXXXX XXXXXXXX		IPCP0 [R] H, W XXXXXXXX XXXXXXXX		16-bit Input Capture 0, 1
000000E8 <sub>H</sub>	—		ICS01 [R/W] B, H, W 00000000		
000000EC <sub>H</sub>	IPCP3 [R] H, W XXXXXXXX XXXXXXXX		IPCP2 [R] H, W XXXXXXXX XXXXXXXX		16-bit Input Capture 2, 3
000000F0 <sub>H</sub>	—		ICS23 [R/W] B, H, W 00000000		
000000F4 <sub>H</sub> to 00000104 <sub>H</sub>	—				Reserved
00000108 <sub>H</sub>	OCCP1 [R/W] H, W XXXXXXXX XXXXXXXX		OCCP0 [R/W] H, W XXXXXXXX XXXXXXXX		16-bit Output Compare
0000010C <sub>H</sub>	—				
00000110 <sub>H</sub>	—		OCS01 [R/W] B, H, W 11101100 00001100		
00000114 <sub>H</sub> to 0000012C <sub>H</sub>	—				Reserved
00000130 <sub>H</sub>	PWCSR0 [R/W] B, H, W 0000000X 00000000		PWCR0 [R] H, W 00000000 00000000		16-bit PWC
00000134 <sub>H</sub>	—				
00000138 <sub>H</sub>	—	PDIVR0 [R/W] B, H, W -----000	—		
0000013C <sub>H</sub> to 00000140 <sub>H</sub>	—				Reserved
00000144 <sub>H</sub>	—	WTDBL [R/W] B -----0	WTCR [R/W] B, H 00000000 000-00-0		Real Time Clock
00000148 <sub>H</sub>	—	WTBR [R/W] B ---XXXXX XXXXXXXX XXXXXXXX			
0000014C <sub>H</sub>	WTHR [R/W] B, H --XXXXX	WTMR [R/W] B, H --XXXXX	WTSR [R/W] B --XXXXX	—	
00000150 <sub>H</sub>	ADERH [R/W] B, H, W 00000000 00000000		ADERL [R/W] B, H, W 00000000 00000000		A/D Converter
00000154 <sub>H</sub>	ADCS1 [R/W] B, H, W 00000000	ADCS0 [R/W] B, H, W 00000000	ADCR1 [R] B, H, W -----XX	ADCR0 [R] B, H, W XXXXXXXX	

(Continued)

# MB91245/S Series

Address	Register				Block
	+ 0	+ 1	+ 2	+ 3	
00000158 <sub>H</sub>	ADCT1 [R/W] B, H, W 00010000	ADCT0 [R/W] B, H, W 00101100	ADSCH [R/W] B, H, W ---00000	ADECH [R/W] B, H, W ---00000	A/D Converter
0000015C <sub>H</sub>	CUCR [R/W] B, H, W -----0--00		CUTD [R/W] B, H, W 10000000 00000000		Clock Calibrator
00000160 <sub>H</sub>	CUTR1 [R] B, H, W -----00000000		CUTR2 [R] B, H, W 00000000 00000000		
00000164 <sub>H</sub>	PWC20 [R/W] B, H, W XXXXXXXXXX	PWC10 [R/W] B, H, W XXXXXXXXXX	—	Reserved	Stepping Motor Controller
00000168 <sub>H</sub>	—	PWC0 [R/W] B -0000--0	PWS20 [R/W] B, H, W -00000000	PWS10 [R/W] B, H, W --000000	
0000016C <sub>H</sub>	PWC21 [R/W] B, H, W XXXXXXXXXX	PWC11 [R/W] B, H, W XXXXXXXXXX	—		
00000170 <sub>H</sub>	—	PWC1 [R/W] B -0000--0	PWS21 [R/W] B, H, W -00000000	PWS11 [R/W] B, H, W --000000	
00000174 <sub>H</sub>	PWC22 [R/W] B, H, W XXXXXXXXXX	PWC12 [R/W] B, H, W XXXXXXXXXX	—		
00000178 <sub>H</sub>	—	PWC2 [R/W] B -0000--0	PWS22 [R/W] B, H, W -00000000	PWS12 [R/W] B, H, W --000000	
0000017C <sub>H</sub>	PWC23 [R/W] B, H, W XXXXXXXXXX	PWC13 [R/W] B, H, W XXXXXXXXXX	—		
00000180 <sub>H</sub>	—	PWC3 [R/W] B -0000--0	PWS23 [R/W] B, H, W -00000000	PWS13 [R/W] B, H, W --000000	
00000184 <sub>H</sub>	PWC24 [R/W] B, H, W XXXXXXXXXX	PWC14 [R/W] B, H, W XXXXXXXXXX	—		
00000188 <sub>H</sub>	—	PWC4 [R/W] B -0000--0	PWS24 [R/W] B, H, W -00000000	PWS14 [R/W] B, H, W --000000	
0000018C <sub>H</sub>	PWC25 [R/W] B, H, W XXXXXXXXXX	PWC15 [R/W] B, H, W XXXXXXXXXX	—		
00000190 <sub>H</sub>	—	PWC5 [R/W] B -0000--0	PWS25 [R/W] B, H, W -00000000	PWS15 [R/W] B, H, W --000000	

(Continued)

# MB91245/S Series

Address	Register				Block
	+ 0	+ 1	+ 2	+ 3	
00000194 <sub>H</sub> to 000001A4 <sub>H</sub>	—				Reserved
000001A8 <sub>H</sub>	CANPRE [R/W] B, H, W 00000000	Reserved	—		CAN Prescaler
000001AC <sub>H</sub>	—				Reserved
000001B0 <sub>H</sub>	—	TRG [R/W] B, H, W 00000000	—	REVC [R/W] B, H, W 00000000	PPG0
000001B4 <sub>H</sub>	PRLH0 [R/W] B, H, W XXXXXXXX	PRLL0 [R/W] B, H, W XXXXXXXX	PRLH1 [R/W] B, H, W XXXXXXXX	PRLL1 [R/W] B, H, W XXXXXXXX	
000001B8 <sub>H</sub>	PRLH2 [R/W] B, H, W XXXXXXXX	PRLL2 [R/W] B, H, W XXXXXXXX	PRLH3 [R/W] B, H, W XXXXXXXX	PRLL3 [R/W] B, H, W XXXXXXXX	
000001BC <sub>H</sub>	PPGC0 [R/W] B, H, W 0000000X	PPGC1 [R/W] B, H, W 0000000X	PPGC2 [R/W] B, H, W 0000000X	PPGC3 [R/W] B, H, W 0000000X	
000001C0 <sub>H</sub>	PRLH4 [R/W] B, H, W XXXXXXXX	PRLL4 [R/W] B, H, W XXXXXXXX	PRLH5 [R/W] B, H, W XXXXXXXX	PRLL5 [R/W] B, H, W XXXXXXXX	PPG0
000001C4 <sub>H</sub>	PRLH6 [R/W] B, H, W XXXXXXXX	PRLL6 [R/W] B, H, W XXXXXXXX	PRLH7 [R/W] B, H, W XXXXXXXX	PRLL7 [R/W] B, H, W XXXXXXXX	
000001C8 <sub>H</sub>	PPGC4 [R/W] B, H, W 0000000X	PPGC5 [R/W] B, H, W 0000000X	PPGC6 [R/W] B, H, W 0000000X	PPGC7 [R/W] B, H, W 0000000X	
000001CC <sub>H</sub> to 000001FC <sub>H</sub>	—				Reserved
00000200 <sub>H</sub>	DMACA0 [R/W] B, H, W *1 00000000 0000XXXX XXXXXXXX XXXXXXXX				DMAC
00000204 <sub>H</sub>	DMACB0 [R/W] B, H, W 00000000 00000000 XXXXXXXX XXXXXXXX				
00000208 <sub>H</sub>	DMACA1 [R/W] B, H, W *1 00000000 0000XXXX XXXXXXXX XXXXXXXX				
0000020C <sub>H</sub>	DMACB1 [R/W] B, H, W 00000000 00000000 XXXXXXXX XXXXXXXX				
00000210 <sub>H</sub>	DMACA2 [R/W] B, H, W *1 00000000 0000XXXX XXXXXXXX XXXXXXXX				
00000214 <sub>H</sub>	DMACB2 [R/W] B, H, W 00000000 00000000 XXXXXXXX XXXXXXXX				

(Continued)

# MB91245/S Series

Address	Register				Block
	+ 0	+ 1	+ 2	+ 3	
00000218 <sub>H</sub>	DMACA3 [R/W] B, H, W *1 00000000 0000XXXX XXXXXXXX XXXXXXXX				DMAC
0000021C <sub>H</sub>	DMACB3 [R/W] B, H, W 00000000 00000000 XXXXXXXX XXXXXXXX				
00000220 <sub>H</sub>	DMACA4 [R/W] B, H, W *1 00000000 0000XXXX XXXXXXXX XXXXXXXX				
00000224 <sub>H</sub>	DMACB4 [R/W] B, H, W 00000000 00000000 XXXXXXXX XXXXXXXX				
00000228 <sub>H</sub> to 0000023C <sub>H</sub>	—				
00000240 <sub>H</sub>	DMACR [R/W] B 0XX00000 XXXXXXXX XXXXXXXX XXXXXXXX				
00000244 <sub>H</sub> to 000003EC <sub>H</sub>	—				Reserved
000003F0 <sub>H</sub>	BSD0 [W] W XXXXXXXX XXXXXXXX XXXXXXXX XXXXXXXX				Bit Search Module
000003F4 <sub>H</sub>	BSD1 [R/W] W XXXXXXXX XXXXXXXX XXXXXXXX XXXXXXXX				
000003F8 <sub>H</sub>	BSDC [W] W XXXXXXXX XXXXXXXX XXXXXXXX XXXXXXXX				
000003FC <sub>H</sub>	BSRR [R] W XXXXXXXX XXXXXXXX XXXXXXXX XXXXXXXX				
00000400 <sub>H</sub>	DDR0 [R/W] B, H, W 00000000	DDR1 [R/W] B, H, W 00000000	DDR2 [R/W] B, H, W 11111111	DDR3 [R/W] B, H, W 00001111	Port Direction Register
00000404 <sub>H</sub>	DDR4 [R/W] B, H, W 00000000	DDR5 [R/W] B, H, W 00000000	DDR6 [R/W] B, H, W 00000000	DDR7 [R/W] B, H, W ----0000	
00000408 <sub>H</sub>	DDR8 [R/W] B, H, W 00000000	DDR9 [R/W] B, H, W 00000000	DDRA [R/W] B, H, W ----0000	DDRB [R/W] B, H, W 00000000	
0000040C <sub>H</sub>	DDRC [R/W] B, H, W ----0000	DDRD [R/W] B, H, W 1111----	DDRE [R/W] B, H, W 00000000	DDRF [R/W] B, H, W 00000000	
00000410 <sub>H</sub>	DDRG [R/W] B, H, W ----0000	—			
00000414 <sub>H</sub> to 0000041C <sub>H</sub>	—				Reserved
00000420 <sub>H</sub>	PFR0 [R/W] B, H, W 00000000	PFR1 [R/W] B, H, W 00000000	PFR2 [R/W] B, H, W 00000000	PFR3 [R/W] B, H, W 00000000	Port Function Register
00000424 <sub>H</sub>	PFR4 [R/W] B, H, W 00000000	PFR5 [R/W] B, H, W 00000000	—	PFR7 [R/W] B, H, W ----0000	

(Continued)

# MB91245/S Series

Address	Register				Block
	+ 0	+ 1	+ 2	+ 3	
00000428 <sub>H</sub>	—		PFRA [R/W] B, H, W ---0000	PFRB [R/W] B, H, W 00000000	Port Function Register
0000042C <sub>H</sub>	PFRC [R/W] B, H, W ---0000	PFRD [R/W] B, H, W 00000000	PFRE [R/W] B, H, W 00000000	—	
00000430 <sub>H</sub>	PFRG [R/W] B, H, W ---0000	—			
00000434 <sub>H</sub> to 0000043C <sub>H</sub>	—				Reserved
00000440 <sub>H</sub>	ICR00 [R/W] B, H, W ---11111	ICR01 [R/W] B, H, W ---11111	ICR02 [R/W] B, H, W ---11111	ICR03 [R/W] B, H, W ---11111	Interrupt Control Unit
00000444 <sub>H</sub>	ICR04 [R/W] B, H, W ---11111	ICR05 [R/W] B, H, W ---11111	ICR06 [R/W] B, H, W ---11111	ICR07 [R/W] B, H, W ---11111	
00000448 <sub>H</sub>	ICR08 [R/W] B, H, W ---11111	ICR09 [R/W] B, H, W ---11111	ICR10 [R/W] B, H, W ---11111	ICR11 [R/W] B, H, W ---11111	
0000044C <sub>H</sub>	ICR12 [R/W] B, H, W ---11111	ICR13 [R/W] B, H, W ---11111	ICR14 [R/W] B, H, W ---11111	ICR15 [R/W] B, H, W ---11111	
00000450 <sub>H</sub>	ICR16 [R/W] B, H, W ---11111	ICR17 [R/W] B, H, W ---11111	ICR18 [R/W] B, H, W ---11111	ICR19 [R/W] B, H, W ---11111	
00000454 <sub>H</sub>	ICR20 [R/W] B, H, W ---11111	ICR21 [R/W] B, H, W ---11111	ICR22 [R/W] B, H, W ---11111	ICR23 [R/W] B, H, W ---11111	
00000458 <sub>H</sub>	ICR24 [R/W] B, H, W ---11111	ICR25 [R/W] B, H, W ---11111	ICR26 [R/W] B, H, W ---11111	ICR27 [R/W] B, H, W ---11111	
0000045C <sub>H</sub>	ICR28 [R/W] B, H, W ---11111	ICR29 [R/W] B, H, W ---11111	ICR30 [R/W] B, H, W ---11111	ICR31 [R/W] B, H, W ---11111	
00000460 <sub>H</sub>	ICR32 [R/W] B, H, W ---11111	ICR33 [R/W] B, H, W ---11111	ICR34 [R/W] B, H, W ---11111	ICR35 [R/W] B, H, W ---11111	
00000464 <sub>H</sub>	ICR36 [R/W] B, H, W ---11111	ICR37 [R/W] B, H, W ---11111	ICR38 [R/W] B, H, W ---11111	ICR39 [R/W] B, H, W ---11111	
00000468 <sub>H</sub>	ICR40 [R/W] B, H, W ---11111	ICR41 [R/W] B, H, W ---11111	ICR42 [R/W] B, H, W ---11111	ICR43 [R/W] B, H, W ---11111	
0000046C <sub>H</sub>	ICR44 [R/W] B, H, W ---11111	ICR45 [R/W] B, H, W ---11111	ICR46 [R/W] B, H, W ---11111	ICR47 [R/W] B, H, W ---11111	
00000470 <sub>H</sub> to 0000047C <sub>H</sub>	—				
00000480 <sub>H</sub>	RSRR [R/W] B, H, W 10000000	STCR [R/W] B, H, W 00110011	TBCR [R/W] B, H, W 00XXXX11	CTBR [W] B, H, W XXXXXXXXXX	Clock Control Unit
00000484 <sub>H</sub>	CLKR [W] B, H, W 00000000	WPR [R/W] B, H, W XXXXXXXXXX	DIVR0 [R/W] B, H, W 00000011	DIVR1 [R/W] B, H, W 00000000	
00000488 <sub>H</sub>	—		OSCCR [R/W] B X000XXX0	—	

(Continued)



# MB91245/S Series

Address	Register				Block
	+ 0	+ 1	+ 2	+ 3	
0000048CH	—				Clock Control Unit
00000490H	OSCR [R/W] B 000--001	—			
00000494H to 000004F8H	—				Reserved
000004FCH	PSCR [W] B XXXXXXXX	—			Port Input Level Select Register
00000500H to 0000053CH	—				Reserved
00000540H	PILR0 [R/W] B, H, W 00000000	PILR1 [R/W] B, H, W 00000000	—		Port Input Level Select Register
00000544H	—	PILR5 [R/W] B, H, W 0-----	—		
00000548H to 00000550H	—				
00000554H to 00000578H	—				Reserved
0000057CH	Reserved	LVRC [R/W] B, H, W 00011000	Reserved	Reserved	CPU Detection of operation
00000580H to 000005FCH	—				Reserved
00000600H	—		EPFR2 [R/W] B, H, W 00000000	EPFR3 [R/W] B, H, W 00000000	Extended Port Function Register
00000604H	EPFR4 [R/W] B, H, W 00000000	EPFR5 [R/W] B, H, W 00000000	—		
00000608H	—				
0000060CH	—	EPFRD [R/W] B, H, W 00000000	—		Extended Port Function Register
00000610H	EPFRG [R/W] B, H, W ----0000	—			
00000614H to 0000063CH	—				Reserved

(Continued)

# MB91245/S Series

Address	Register				Block
	+ 0	+ 1	+ 2	+ 3	
00000640 <sub>H</sub>	ASR0 [R/W] B, H, W 00000000 00000000		ACR0 [R/W] B, H, W 1111XX00 00000000		External Bus Control Unit
00000644 <sub>H</sub>	ASR1 [R/W] B, H, W XXXXXXXX XXXXXXXX		ACR1 [R/W] B, H, W XXXXXXXX XXXXXXXX		
00000648 <sub>H</sub>	ASR2 [R/W] B, H, W XXXXXXXX XXXXXXXX		ACR2 [R/W] B, H, W XXXXXXXX XXXXXXXX		
0000064C <sub>H</sub>	ASR3 [R/W] B, H, W XXXXXXXX XXXXXXXX		ACR3 [R/W] B, H, W XXXXXXXX XXXXXXXX		
00000650 <sub>H</sub> to 0000065C <sub>H</sub>	—				
00000660 <sub>H</sub>	AWR0 [R/W] B, H, W 01110000 01011011		AWR1 [R/W] B, H, W XXXX0000 XX0X1XXX		
00000664 <sub>H</sub>	AWR2 [R/W] B, H, W 0XXX0000 XX0X1XXX		AWR3 [R/W] B, H, W 0XXX0000 0X0X1XXX		
00000668 <sub>H</sub> to 0000067C <sub>H</sub>	—				Reserved
00000680 <sub>H</sub>	CSER [R/W] B, H, W XXXX0001	—			External Bus Control Unit
00000684 <sub>H</sub> to 000007F8 <sub>H</sub>	—				Reserved
000007FC <sub>H</sub>	—	MODR *2	—		Mode register
00000800 <sub>H</sub> to 00000FFC <sub>H</sub>	—				Reserved
00001000 <sub>H</sub>	DMASA0 [R/W] W XXXXXXXX XXXXXXXX XXXXXXXX XXXXXXXX				DMAC
00001004 <sub>H</sub>	DMADA0 [R/W] W XXXXXXXX XXXXXXXX XXXXXXXX XXXXXXXX				
00001008 <sub>H</sub>	DMASA1 [R/W] W XXXXXXXX XXXXXXXX XXXXXXXX XXXXXXXX				
0000100C <sub>H</sub>	DMADA1 [R/W] W XXXXXXXX XXXXXXXX XXXXXXXX XXXXXXXX				
00001010 <sub>H</sub>	DMASA2 [R/W] W XXXXXXXX XXXXXXXX XXXXXXXX XXXXXXXX				
00001014 <sub>H</sub>	DMADA2 [R/W] W XXXXXXXX XXXXXXXX XXXXXXXX XXXXXXXX				
00001018 <sub>H</sub>	DMASA3 [R/W] W XXXXXXXX XXXXXXXX XXXXXXXX XXXXXXXX				

(Continued)

# MB91245/S Series

Address	Register				Block
	+ 0	+ 1	+ 2	+ 3	
0000101C <sub>H</sub>	DMADA3 [R/W] W XXXXXXXX XXXXXXXX XXXXXXXX XXXXXXXX				DMAC
00001020 <sub>H</sub>	DMASA4 [R/W] W XXXXXXXX XXXXXXXX XXXXXXXX XXXXXXXX				
00001024 <sub>H</sub>	DMADA4 [R/W] W XXXXXXXX XXXXXXXX XXXXXXXX XXXXXXXX				
00001028 <sub>H</sub> to 00006FFC <sub>H</sub>	—				Reserved
00007000 <sub>H</sub>	FLCR [R/W] 01XX1000	—		—	Flash I/F (Only Mass Production Product)
00007004 <sub>H</sub>	FLWC [R/W] 00000011	—		—	
00007008 <sub>H</sub> to 0000FFFC <sub>H</sub>	—				Reserved
00020000 <sub>H</sub>	CTRLR0		STATR0		CAN0
00020004 <sub>H</sub>	ERRCNT0		BTR0		
00020008 <sub>H</sub>	INTR0		TESTR0		
0002000C <sub>H</sub>	BRPER0		—		
00020010 <sub>H</sub>	IF1CREQ0		IF1CMSK0		
00020014 <sub>H</sub>	IF1MSK20		IF1MSK10		
00020018 <sub>H</sub>	IF1ARB20		IF1ARB10		
0002001C <sub>H</sub>	IF1MCTR0		—		
00020020 <sub>H</sub>	IF1DTA10		IF1DTA20		
00020024 <sub>H</sub>	IF1DTB10		IF1DTB20		
00020028 <sub>H</sub> , 0002002C <sub>H</sub>	—				
00020030 <sub>H</sub>	Reserved (IF1 data A mirror, little endian byte ordering)				
00020034 <sub>H</sub>	Reserved (IF1 data B mirror, little endian byte ordering)				
00020038 <sub>H</sub> , 0002003C <sub>H</sub>	—				
00020040 <sub>H</sub>	IF2CREQ0		IF2CMSK0		
00020044 <sub>H</sub>	IF2MSK20		IF2MSK10		
00020048 <sub>H</sub>	IF2ARB20		IF2ARB10		
0002004C <sub>H</sub>	IF2MCTR0		—		
00020050 <sub>H</sub>	IF2DTA10		IF2DTA20		
00020054 <sub>H</sub>	IF2DTB10		IF2DTB20		

(Continued)

# MB91245/S Series

Address	Register				Block
	+ 0	+ 1	+ 2	+ 3	
00020058 <sub>H</sub> , 0002005C <sub>H</sub>	—				CAN0
00020060 <sub>H</sub>	Reserved (IF2 data A mirror, little endian byte ordering)				
00020064 <sub>H</sub>	Reserved (IF2 data B mirror, little endian byte ordering)				
00020068 <sub>H</sub> , 0002007C <sub>H</sub>	—				
00020080 <sub>H</sub>	TREQR20		TREQR10		
00020084 <sub>H</sub>	Reserved (> 32..128 Message buffer)				
00020088 <sub>H</sub> , 0002008C <sub>H</sub>	—				
00020090 <sub>H</sub>	NEWDT20		NEWDT10		
00020094 <sub>H</sub>	Reserved (> 32..128 Message buffer)				
00020098 <sub>H</sub> , 0002009C <sub>H</sub>	—				
000200A0 <sub>H</sub>	INTPEND20		INTPEND10		
000200A4 <sub>H</sub>	Reserved (> 32..128 Message buffer)				
000200A8 <sub>H</sub> , 000200AC <sub>H</sub>	—				
000200B0 <sub>H</sub>	MESVAL20		MESVAL10		
000200B4 <sub>H</sub>	Reserved (> 32..128 Message buffer)				
000200B8 <sub>H</sub> , 000200FC <sub>H</sub>	—				
00020100 <sub>H</sub>	CTRLR1		STATR1		CAN1
00020104 <sub>H</sub>	ERRCNT1		BTR1		
00020108 <sub>H</sub>	INTR1		TESTR1		
0002010C <sub>H</sub>	BRPER1		—		
00020110 <sub>H</sub>	IF1CREQ1		IF1CMSK1		
00020114 <sub>H</sub>	IF1MSK21		IF1MSK11		
00020118 <sub>H</sub>	IF1ARB21		IF1ARB11		
0002011C <sub>H</sub>	IF1MCTR1		—		
00020120 <sub>H</sub>	IF1DTA11		IF1DTA21		
00020124 <sub>H</sub>	IF1DTB11		IF1DTB21		
00020128 <sub>H</sub> , 0002012C <sub>H</sub>	—				
00020130 <sub>H</sub>	Reserved (IF1 data A mirror, little endian byte ordering)				
00020134 <sub>H</sub>	Reserved (IF1 data B mirror, little endian byte ordering)				
00020138 <sub>H</sub> , 0002013C <sub>H</sub>	—				

(Continued)

# MB91245/S Series

(Continued)

Address	Register				Block
	+ 0	+ 1	+ 2	+ 3	
00020140H	IF2CREQ1		IF2CMSK1		CAN1
00020144H	IF2MSK21		IF2MSK11		
00020148H	IF2ARB21		IF2ARB11		
0002014CH	IF2MCTR1		—		
00020150H	IF2DTA11		IF2DTA21		
00020154H	IF2DTB11		IF2DTB21		
00020158H, 0002015CH	—				
00020160H	Reserved (IF2 data A mirror, little endian byte ordering)				
00020164H	Reserved (IF2 data B mirror, little endian byte ordering)				
00020168H, 0002017CH	—				
00020180H	TREQR21		TREQR11		
00020184H	Reserved (> 32..128 Message buffer)				
00020188H, 0002018CH	—				
00020190H	NEWDT21		NEWDT11		
00020194H	Reserved (> 32..128 Message buffer)				
00020198H, 0002019CH	—				
000201A0H	INTPND21		INTPND11		
000201A4H	Reserved (> 32..128 Message buffer)				
000201A8H, 000201ACH	—				
000201B0H	MESVAL21		MESVAL11		
000201B4H	Reserved (> 32..128 Message buffer)				
000201B8H, 000201FCH	—				
00038000H to 003FFFFCH	—				F-bus RAM 32 Kbytes
0003C000H to 003FFFFCH	—				F-bus RAM 16 Kbytes
0003E000H to 003FFFFCH	—				F-bus RAM 8 Kbytes

\*1 : The lower 16 bits (DTC [15 : 0]) of DMACA0 to DMACA4 cannot be accessed in bytes.

\*2 : This register is set by a mode vector fetch and cannot be accessed by the user.

# MB91245/S Series

Address	Register				Block
	+ 0	+ 1	+ 2	+ 3	
000C0000 <sub>H</sub> to 000FFFFC <sub>H</sub>	—				User ROM 256 Kbytes (Only Mass Production Product)

Address	Register				Block
	+ 0	+ 1	+ 2	+ 3	
000E0000 <sub>H</sub> to 000FFFFC <sub>H</sub>	—				User ROM 128 Kbytes (MB91247)

## ■ VECTOR TABLE

Interrupt source	Interrupt number		Interrupt level	Offset	TBR default address	DMA start source
	Decimal	Hexa-decimal				
Reset	0	00	—	3FC <sub>H</sub>	000FFFFC <sub>H</sub>	—
Mode vector	1	01	—	3F8 <sub>H</sub>	000FFFF8 <sub>H</sub>	—
System reserved	2	02	—	3F4 <sub>H</sub>	000FFFF4 <sub>H</sub>	—
System reserved	3	03	—	3F0 <sub>H</sub>	000FFFF0 <sub>H</sub>	—
System reserved	4	04	—	3EC <sub>H</sub>	000FFFECH	—
System reserved	5	05	—	3E8 <sub>H</sub>	000FFFE8 <sub>H</sub>	—
System reserved	6	06	—	3E4 <sub>H</sub>	000FFFE4 <sub>H</sub>	—
Coprocessor absent trap	7	07	—	3E0 <sub>H</sub>	000FFFE0 <sub>H</sub>	—
Coprocessor error trap	8	08	—	3DC <sub>H</sub>	000FFFDCH	—
INTE instruction	9	09	—	3D8 <sub>H</sub>	000FFFD8 <sub>H</sub>	—
System reserved	10	0A	—	3D4 <sub>H</sub>	000FFFD4 <sub>H</sub>	—
System reserved	11	0B	—	3D0 <sub>H</sub>	000FFFD0 <sub>H</sub>	—
Step trace trap	12	0C	—	3CC <sub>H</sub>	000FFFCCH	—
NMI request (ICE)	13	0D	—	3C8 <sub>H</sub>	000FFFC8 <sub>H</sub>	—
Undefined instruction exception	14	0E	—	3C4 <sub>H</sub>	000FFFC4 <sub>H</sub>	—
NMI instruction	15	0F	15 (F <sub>H</sub> ) Fixed	3C0 <sub>H</sub>	000FFFC0 <sub>H</sub>	—
External interrupt 0	16	10	ICR00	3BC <sub>H</sub>	000FFFBCH	6
External interrupt 1	17	11	ICR01	3B8 <sub>H</sub>	000FFFB8 <sub>H</sub>	7
External interrupt 2	18	12	ICR02	3B4 <sub>H</sub>	000FFFB4 <sub>H</sub>	—
External interrupt 3	19	13	ICR03	3B0 <sub>H</sub>	000FFFB0 <sub>H</sub>	—
External interrupt 4	20	14	ICR04	3AC <sub>H</sub>	000FFFAC <sub>H</sub>	—
External interrupt 5	21	15	ICR05	3A8 <sub>H</sub>	000FFFA8 <sub>H</sub>	—
External interrupt 6	22	16	ICR06	3A4 <sub>H</sub>	000FFFA4 <sub>H</sub>	—
External interrupt 7	23	17	ICR07	3A0 <sub>H</sub>	000FFFA0 <sub>H</sub>	—
Reload timer 0 (Underflow)	24	18	ICR08	39C <sub>H</sub>	000FFF9C <sub>H</sub>	—
Reload timer 1 (Underflow)	25	19	ICR09	398 <sub>H</sub>	000FFF98 <sub>H</sub>	9
Reload timer 2 (Underflow)	26	1A	ICR10	394 <sub>H</sub>	000FFF94 <sub>H</sub>	10
UART0 (Reception completed/error)	27	1B	ICR11	390 <sub>H</sub>	000FFF90 <sub>H</sub>	0
UART0 (Transmission completed)	28	1C	ICR12	38C <sub>H</sub>	000FFF8C <sub>H</sub>	3
LIN-UART0 (Reception completed/ error, LIN Sync break, bus idle)	29	1D	ICR13	388 <sub>H</sub>	000FFF88 <sub>H</sub>	1

(Continued)

# MB91245/S Series

Interrupt source	Interrupt number		Interrupt level	Offset	TBR default address	DMA start source
	Decimal	Hexa-decimal				
LIN-UART0 (Transmission completed)	30	1E	ICR14	384 <sub>H</sub>	000FFF84 <sub>H</sub>	4
LIN-UART1 (Reception completed/error, LIN Sync break, bus idle)	31	1F	ICR15	380 <sub>H</sub>	000FFF80 <sub>H</sub>	2
LIN-UART1 (Transmission completed)	32	20	ICR16	37C <sub>H</sub>	000FFF7C <sub>H</sub>	5
LIN-UART2 (Reception completed/error, LIN Sync break, bus idle)	33	21	ICR17	378 <sub>H</sub>	000FFF78 <sub>H</sub>	—
LIN-UART2 (Transmission completed)	34	22	ICR18	374 <sub>H</sub>	000FFF74 <sub>H</sub>	—
CAN0 Reception/Transmission completed Node status transition	35	23	ICR19	370 <sub>H</sub>	000FFF70 <sub>H</sub>	—
CAN1 Reception/Transmission completed Node status transition	36	24	ICR20	36C <sub>H</sub>	000FFF6C <sub>H</sub>	—
System reserved	37	25	ICR21	368 <sub>H</sub>	000FFF68 <sub>H</sub>	—
System reserved	38	26	ICR22	364 <sub>H</sub>	000FFF64 <sub>H</sub>	—
System reserved	39	27	ICR23	360 <sub>H</sub>	000FFF60 <sub>H</sub>	—
PWC (Measurement completed)	40	28	ICR24	35C <sub>H</sub>	000FFF5C <sub>H</sub>	—
PWC (Overflow)	41	29	ICR25	358 <sub>H</sub>	000FFF58 <sub>H</sub>	—
DMAC transfer completed/error	42	2A	ICR26	354 <sub>H</sub>	000FFF54 <sub>H</sub>	—
A/D converter	43	2B	ICR27	350 <sub>H</sub>	000FFF50 <sub>H</sub>	14
Real-time clock Hour/minute/second overflow, corrected	44	2C	ICR28	34C <sub>H</sub>	000FFF4C <sub>H</sub>	—
System reserved	45	2D	ICR29	348 <sub>H</sub>	000FFF48 <sub>H</sub>	—
Main oscillation stabilization wait timer	46	2E	ICR30	344 <sub>H</sub>	000FFF44 <sub>H</sub>	—
Timebase timer overflow	47	2F	ICR31	340 <sub>H</sub>	000FFF40 <sub>H</sub>	—
PPG0/1 underflow	48	30	ICR32	33C <sub>H</sub>	000FFF3C <sub>H</sub>	—
PPG2/3 underflow	49	31	ICR33	338 <sub>H</sub>	000FFF38 <sub>H</sub>	—
PPG4/5 underflow	50	32	ICR34	334 <sub>H</sub>	000FFF34 <sub>H</sub>	—
PPG6/7 underflow	51	33	ICR35	330 <sub>H</sub>	000FFF30 <sub>H</sub>	—
16-bit free-run timer 0 Overflow & OCU0 Compare match clear	52	34	ICR36	32C <sub>H</sub>	000FFF2C <sub>H</sub>	—

(Continued)



(Continued)

Interrupt source	Interrupt number		Interrupt level	Offset	TBR default address	DMA start source
	Decimal	Hexa-decimal				
16-bit free-run timer 1 Overflow	53	35	ICR37	328 <sub>H</sub>	000FFF28 <sub>H</sub>	—
ICU0 (Capture)	54	36	ICR38	324 <sub>H</sub>	000FFF24 <sub>H</sub>	—
ICU1 (Capture)	55	37	ICR39	320 <sub>H</sub>	000FFF20 <sub>H</sub>	—
ICU2 (Capture)	56	38	ICR40	31C <sub>H</sub>	000FFF1C <sub>H</sub>	—
ICU3 (Capture)	57	39	ICR41	318 <sub>H</sub>	000FFF18 <sub>H</sub>	—
OCU0 (Match)	58	3A	ICR42	314 <sub>H</sub>	000FFF14 <sub>H</sub>	—
OCU1 (Match)	59	3B	ICR43	310 <sub>H</sub>	000FFF10 <sub>H</sub>	—
System reserved	60	3C	ICR44	30C <sub>H</sub>	000FFF0C <sub>H</sub>	—
System reserved	61	3D	ICR45	308 <sub>H</sub>	000FFF08 <sub>H</sub>	—
Sound generator setup count completed	62	3E	ICR46	304 <sub>H</sub>	000FFF04 <sub>H</sub>	—
Delay interrupt source bit	63	3F	ICR47	300 <sub>H</sub>	000FFF00 <sub>H</sub>	—
System reserved (Used by REALOS)	64	40	—	2FC <sub>H</sub>	000FFEFC <sub>H</sub>	—
System reserved (Used by REALOS)	65	41	—	2F8 <sub>H</sub>	000FFEFC <sub>H</sub>	—
System reserved	66 to 79	42 to 4F	—	2F4 <sub>H</sub> to 2C0 <sub>H</sub>	000FFEFC <sub>H</sub> to 000FFEC0 <sub>H</sub>	—
Used by INT instruction	80 to 255	50 to FF	—	2BC <sub>H</sub> to 000 <sub>H</sub>	000FFEBC <sub>H</sub> to 000FFC00 <sub>H</sub>	—

# MB91245/S Series

## ■ TABLE OF PIN STATUS IN EACH MODE

### • Single chip mode

Pin name	Function name	Initial value		In sleep state	In stop state	
		$\overline{\text{INIT}} = \text{"L"}$	$\overline{\text{INIT}} = \text{"H"}$		HIZ = 0	HIZ = 1
$\overline{\text{INIT}}$	$\overline{\text{INIT}}$	Input enabled	Input enabled	Input enabled	Input enabled	Input enabled
X0	X0				Hi-Z or input enabled	Hi-Z or input enabled
X1	X1				"H" output or input enabled	"H" output or input enabled
X0A	X0A				Hi-Z or input enabled	Hi-Z or input enabled
X1A	X1A				"H" output or input enabled	"H" output or input enabled
MOD0	MOD0				Input enabled	Input enabled
MOD1	MOD1					
MOD2	MOD2					
P00	P00/SEG24/INT0/D00	Output Hi-Z input enabled	Output Hi-Z input enabled	P : Immediately preceding status held F : Operation or output held during LCDC output; INT0 to INT5 input enabled when PFR0 register is set to "0"	Operation or output held during LCDC output, otherwise output Hi-Z / INT0 to INT5 input enabled when PFR0 register is set to "0"	
P01	P01/SEG25/INT1/D01					
P02	P02/SEG26/INT2/D02					
P03	P03/SEG27/INT3/D03					
P04	P04/SEG28/INT4/D04					
P05	P05/SEG29/INT5/D05					
P06	P06/SEG30/D06					
P07	P07/SEG31/ATG/D07					
P10 to P17	P10 to P17/ SEG16 to SEG23/ D08 to D15	"L" output	"L" output	P : Normal operation performed F : Operation or output held during LCDC output; Otherwise Hi-Z	Operation or output held during LCDC output; Otherwise output Hi-Z/ Input fixed to "0"	
P20 to P27	P20 to P27/ SEG00 to SEG07/ A00 to A07					
P30 to P33	P30 to P33/ SEG08 to SEG11/ A08 to A11					
P34 to P37	P34 to P37/ SEG12 to SEG15/ A12 to A15	Output Hi-Z input enabled	Output Hi-Z input enabled			

(Continued)

# MB91245/S Series

Pin name	Function name	Initial value		In sleep state	In stop state	
		$\overline{\text{INIT}} = \text{"L"}$	$\overline{\text{INIT}} = \text{"H"}$		HIZ = 0	HIZ = 1
P40	P40/SIN0	Output Hi-Z input enabled	Output Hi-Z input enabled	P : Immediately preceding status held F : Normal operation performed	P : Immediately preceding status held F : Output held or Hi-Z	Output Hi-Z / Input fixed to "0"
P41	P41/SOT0					
P42	P42/SCK0					
P43	P43/SIN3					
P44	P44/SOT3					
P45	P45/SCK3					
P46	P46/SGA/ $\overline{\text{AS}}$					
P47	P47/SGO/SYSCLK					
P50	P50/SIN4/CK0/ $\overline{\text{CS0}}$					
P51	P51/SOT4/ $\overline{\text{CS1}}$					
P52	P52/SCK4/ $\overline{\text{CS2}}$					
P53	P53/SIN5/CK1/ $\overline{\text{CS3}}$					
P54	P54/SOT5/ $\overline{\text{RD}}$					
P55	P55/SCK5/ $\overline{\text{WR0}}$					
P56	P56/OUT0/ $\overline{\text{WR1}}$					
P57	P57/OUT1/RDY					
P60 to P67	P60 to P67/AN0 to AN7					
P70	P70/RX0/INT6				P : Immediately preceding status held F : Output held, INT6 input enabled	Output Hi-Z / INT6 input enabled when PFR7 register is set to "1"
P71	P71/TX0				P : Immediately preceding status held, F : Hi-Z	Output Hi-Z / Input fixed to "0"
P72	P72/RX1/INT7				P : Immediately preceding status held F : Output held, INT7 input enabled	Output Hi-Z / INT7 input enabled when PFR7 register is set to "1"

(Continued)

# MB91245/S Series

(Continued)

Pin name	Function name	Initial value		In sleep state	In stop state	
		$\overline{\text{INIT}} = \text{"L"}$	$\overline{\text{INIT}} = \text{"H"}$		HIZ = 0	HIZ = 1
P73	P73/TX0	Output Hi-Z input enabled	Output Hi-Z input enabled	P : Immediately preceding status held F : Normal operation performed	P : Immediately preceding status held F : Output held or Hi-Z	Output Hi-Z / Input fixed to "0"
P80 to P87	P80 to P87/AN16 to AN23					
P90 to P97	P90 to P97/AN24 to AN31					
PA0 to PA3	PA0 to PA3/ PWMxxx to PWMxxx					
PB0 to PB7	PB0 to PB7/ PWMxxx to PWMxxx					
PC0 to PC3	PC0 to PC3/ PWMxxx to PWMxxx					
PD0	PD0/TIN0/IN0/PWC0	Input enabled	Input enabled	Input enabled	Hi-Z	
PD1	PD1/TIN1/IN1					
PD2	PD2/TIN2/IN2					
PD3	PD3/IN3					
PD4	PD4/COM0/PPG1	"L" output	"L" output	P : Immediately preceding status held F : Normal operation performed	P : Immediately preceding status held LCDC : Output or hold PPG : Output held	Input fixed to "0"
PD5	PD5/COM1/PPG3					
PD6	PD6/COM2/PPG5					
PD7	PD7/COM3/PPG7					
PE0 to PE7	PE0 to PE7/ PWMxxx to PWMxxx	Output Hi-Z Input enabled	Output Hi-Z Input enabled	P : Immediately preceding status held F : Normal operation performed	P : Immediately preceding status held F : Output held or Hi-Z	Output Hi-Z / Input fixed to "0"
PF0 to PF7	PF0 to PF7/AN8 to AN15					
PG0	PG0/ (WOT) /PPG0					
PG1	PG1/TOT0/PPG2					
PG2	PG2/TOT1/PPG4					
PG3	PG3/TOT2/PPG6					

# MB91245/S Series

## • External bus mode (8-bit)

Pin name	Function name	Initial value		In sleep mode	In stop mode	
		$\overline{\text{INIT}} = \text{"L"}$	$\overline{\text{INIT}} = \text{"H"}$		HIZ = 0	HIZ = 1
$\overline{\text{INIT}}$	$\overline{\text{INIT}}$	Input enabled	Input enabled	Input enabled	Input enabled	Input enabled
X0	X0				Hi-Z or input enabled	Hi-Z or input enabled
X1	X1				"H" output or input enabled	"H" output or input enabled
X0A	X0A				Hi-Z or input enabled	Hi-Z or input enabled
X1A	X1A				"H" output or input enabled	"H" output or input enabled
MOD0	MOD0				Input enabled	Input enabled
MOD1	MOD1					
MOD2	MOD2					
P00	P00/SEG24/ INT0	Output Hi-Z input enabled	Output Hi-Z input enabled	P : Immediately preceding status held F : Normal operation performed	P : Immediately preceding status held F : Operation or output held during LCDC output; INT0 to INT5 input enabled when PFR0 register is set to "0"	Operation or output held during LCDC output, otherwise output Hi-Z / INT0 to INT5 input enabled when PFR0 register is set to "0"
P01	P01/SEG25/ INT1					
P02	P02/SEG26/ INT2					
P03	P03/SEG27/ INT3					
P04	P04/SEG28/ INT4					
P05	P05/SEG29/ INT5					
P06	P06/SEG30					
P07	P07/SEG31/ ATG	Hi-Z	Hi-Z	Hi-Z	P : Immediately preceding status held F : Operation or output held during LCDC output, otherwise Hi-Z	Operation or output held during LCDC output, otherwise output Hi-Z / Input fixed to "0"
P10 to P17	D08 to D15				Output Hi-Z / Input fixed to "0"	
P20 to P27	A00 to A07	"L" output	"H" output	F : Address output	F : Address output	Output Hi-Z / Input fixed to "0"
P30 to P33	A08 to A11					

(Continued)

# MB91245/S Series

Pin name	Function name	Initial value		In sleep mode	In stop mode	
		$\overline{\text{INIT}} = \text{"L"}$	$\overline{\text{INIT}} = \text{"H"}$		HIZ = 0	HIZ = 1
P34 to P37	A12 to A15	Output Hi-Z input enabled	"H" output	F : Address output	F : Address output	Output Hi-Z / Input fixed to "0"
P40	P40/SIN0	Output Hi-Z input enabled	Output Hi-Z input enabled	P : Immediately preceding status held F : Normal operation performed	P : Immediately preceding status held F : Output held or Hi-Z	
P41	P41/SOT0					
P42	P42/SCK0					
P43	P43/SIN3					
P44	P44/SOT3					
P45	P45/SCK3					
P46	P46/SGA/ $\overline{\text{AS}}$	Output Hi-Z input enabled	"H" output	P : Immediately preceding status held, $\overline{\text{AS}}$ : "H" output, F : Normal operation performed	P : Immediately preceding status held, $\overline{\text{AS}}$ : "H" output, F : Output held	
P47	P47/SGO/ SYSCLK		CLK output	P : Immediately preceding status held, CLK : CLK output, F : Normal operation performed	P : Immediately preceding status held, CLK : "H" or "L" output, F : Output held	
P50	P50/SIN4/ CK0/ $\overline{\text{CS0}}$		"H" output	Bus control : "H" output P : Immediately preceding status held F : Normal operation performed	Bus control : "H" output P : Immediately preceding status held F : Output held or Hi-Z	
P51	P51/SOT4/ $\overline{\text{CS1}}$					
P52	P52/SCK4/ $\overline{\text{CS2}}$					
P53	P53/SIN5/ CK1/ $\overline{\text{CS3}}$					
P54	P54/SOT5/ $\overline{\text{RD}}$					
P55	P55/SCK5/ $\overline{\text{WR0}}$					

(Continued)

# MB91245/S Series

Pin name	Function name	Initial value		In sleep mode	In stop mode	
		$\overline{\text{INIT}} = \text{"L"}$	$\overline{\text{INIT}} = \text{"H"}$		HIZ = 0	HIZ = 1
P56	P56/OUT0	Output Hi-Z input enabled	"H" output	P : Immediately preceding status held F : Normal operation performed; "H" output when EPFR is set to "0"	P : Immediately preceding status held F : Output held; "H" output when EPFR is set to "0"	Output Hi-Z / Input fixed to "0"
P57	P57/OUT1/RDY		RDY input	P : Immediately preceding status held F : Normal status, RDY input	P : Immediately preceding status held F : Output held, RDY input	
P60 to P67	P60 to P77/AN0 to AN7	Output Hi-Z input enabled	Output Hi-Z input enabled	P : Immediately preceding status held F : Normal operation performed	P : Immediately preceding status held F : Output held or Hi-Z	Output Hi-Z / Input fixed to "0"
P70	P70/RX0/INT6				P : Immediately preceding status held F : Output held, INT6 input enabled	Output Hi-Z / INT6 input enabled when PFR7 register is set to "1"
P71	P71/TX0				P : Immediately preceding status held, F : Hi-Z	Output Hi-Z / Input fixed to "0"
P72	P72/RX1/INT7				P : Immediately preceding status held F : Output held, INT7 input enabled	Output Hi-Z / INT7 input enabled when PFR7 register is set to "1"

(Continued)

# MB91245/S Series

(Continued)

Pin name	Function name	Initial value		In sleep mode	In stop mode	
		$\overline{\text{INIT}} = \text{"L"}$	$\overline{\text{INIT}} = \text{"H"}$		HIZ = 0	HIZ = 1
P80 to P87	P80 to P87/ AN16 to AN23	Output Hi-Z input enabled	Output Hi-Z input enabled	P : Immediately preceding status held F : Normal operation performed	P : Immediately preceding status held F : Normal operation performed	Output Hi-Z/ Input fixed to "0"
P90 to P97	P90 to P97/ AN24 to AN31					
PA0 to PA3	PA0 to PA3/ PWMxxx to PWMxxx					
PB0 to PB7	PB0 to PB7/ PWMxxx to PWMxxx					
PC0 to PC3	PC0 to PC3/ PWMxxx to PWMxxx					
PD0	PD0/TIN0/ IN0/PWC0	Input enabled	Input enabled	Input enabled	Hi-Z	Input fixed to "0"
PD1	PD1/TIN1					
PD2	PD2/TIN2					
PD3	PD3/IN3					
PD4	PD4/COM0/ PPG1	"L" output	"L" output	P : Immediately preceding status held LCDC : Output or hold PPG : Output held	P : Immediately preceding status held LCDC : Output or hold PPG : Output held	Input fixed to "0"
PD5	PD5/COM1/ PPG3					
PD6	PD6/COM2/ PPG5					
PD7	PD7/COM3/ PPG7					
PE0 to PE7	PE0 to PE7/ PWMxxx to PWMxxx	Output Hi-Z Input enabled	Output Hi-Z Input enabled	P : Immediately preceding status held F : Normal operation performed	P : Immediately preceding status held F : Output held or Hi-Z	Output Hi-Z/ Input fixed to "0"
PF0 to PF7	PF0 to PF7/ AN8 to AN15					
PG0	PG0/ (WOT) / PPG0					
PG1	PG1/TOT0/ PPG2					
PG2	PG2/TOT1/ PPG4					
PG3	PG3/TOT2/ PPG6					



# MB91245/S Series

• External bus mode (16-bit)

Pin name	Function name	Initial value		In sleep mode	In stop mode	
		$\overline{\text{INIT}} = \text{"L"}$	$\overline{\text{INIT}} = \text{"H"}$		HIZ = 0	HIZ = 1
$\overline{\text{INIT}}$	$\overline{\text{INIT}}$	Input enabled	Input enabled	Input enabled	Input enabled	Input enabled
X0	X0				Hi-Z or input enabled	Hi-Z or input enabled
X1	X1				"H" output or input enabled	"H" output or input enabled
X0A	X0A				Hi-Z or input enabled	Hi-Z or input enabled
X1A	X1A				"H" output or input enabled	"H" output or input enabled
MOD0	MOD0				Input enabled	Input enabled
MOD1	MOD1					
MOD2	MOD2					
P00	D00	Output Hi-Z input enabled	Output Hi-Z input enabled	Hi-Z	Hi-Z	Output Hi-Z Input fixed to "0"
P01	D01					
P02	D02					
P03	D03					
P04	D04					
P05	D05					
P06	D06					
P07	D07					
P10 to P17	D08 to D15					
P20 to P27	A00 to A07	"L" output	"H" output	F : Address output	F : Address output	
P30 to P33	A08 to A11					
P34 to P37	A12 to A15	Output Hi-Z input enabled	Output Hi-Z input enabled	P : Immediately preceding status held F : Normal operation performed	P : Immediately preceding status held F : Output held or Hi-Z	
P40	P40/SIN0					
P41	P41/SOT0					
P42	P42/SCK0					
P43	P43/SIN3					
P44	P44/SOT3					
P45	P45/SCK3					

(Continued)

# MB91245/S Series

Pin name	Function name	Initial value		In sleep mode	In stop mode	
		$\overline{\text{INIT}} = \text{"L"}$	$\overline{\text{INIT}} = \text{"H"}$		HIZ = 0	HIZ = 1
P46	P46/SGA/ $\overline{\text{AS}}$	Output Hi-Z input enabled	"H" output	P : Immediately preceding status held, $\overline{\text{AS}}$ : "H" output, F : Normal operation performed	P : Immediately preceding status held, $\overline{\text{AS}}$ : "H" output, F : Output held	Output Hi-Z Input fixed to "0"
P47	P47/SGO/ SYSCLK		CLK output	P : Immediately preceding status held, CLK : CLK output, F : Normal operation performed	P : Immediately preceding status held, CLK : "H" or "L" output, F : Output held	
P50	P50/SIN4/ $\overline{\text{CK0/CS0}}$		"H" output	Bus control : "H" output P : Immediately preceding status held F : Normal operation performed	Bus control : "H" output P : Immediately preceding status held F : Output held or Hi-Z	
P51	P51/SOT4/ $\overline{\text{CS1}}$					
P52	P52/SCK4/ $\overline{\text{CS2}}$					
P53	P53/SIN5/ $\overline{\text{CK1/CS3}}$					
P54	P54/SOT5/ $\overline{\text{RD}}$	Output Hi-Z input enabled	"H" output	Bus control : "H" output P : Immediately preceding status held F : Normal operation performed	Bus control : "H" output P : Immediately preceding status held F : Output held or Hi-Z	Output Hi-Z / Input fixed to "0"
P55	P55/SCK5/ $\overline{\text{WR0}}$					
P56	P56/OUT0/ $\overline{\text{WR1}}$					
P57	P57/OUT1/ RDY					
P60 to P67	P60 to P77/ AN0 to AN7	Output Hi-Z input enabled	Output Hi-Z input enabled	P : Immediately preceding status held F : Normal operation performed	P : Immediately preceding status held F : Output held or Hi-Z	Output Hi-Z / Input fixed to "0"

(Continued)

# MB91245/S Series

Pin name	Function name	Initial value		In sleep mode	In stop mode	
		$\overline{\text{INIT}} = \text{"L"}$	$\overline{\text{INIT}} = \text{"H"}$		HIZ = 0	HIZ = 1
P70	P70/RX0/ INT6	Output Hi-Z input enabled	Output Hi-Z input enabled	P : Immediately preceding status held F : Normal operation performed	P : Immediately preceding status held F : Output held, INT6 input enabled	Output Hi-Z / INT6 input enabled when PFR7 register is set to "1"
P71	P71/TX0				P : Immediately preceding status held F : Hi-Z	Output Hi-Z / Input fixed to "0"
P72	P72/RX1/ INT7				P : Immediately preceding status held F : Output held, INT7 input enabled	Output Hi-Z / INT7 input enabled when PFR7 register is set to "1"
P80 to P87	P80 to P87/ AN16 to AN23	Output Hi-Z input enabled	Output Hi-Z input enabled	P : Immediately preceding status held F : Normal operation performed	P : Immediately preceding status held F : Normal operation performed	Output Hi-Z/ Input fixed to "0"
P90 to P97	P90 to P97/ AN24 to AN31					
PA0 to PA3	PA0 to PA3/ PWMxxx to PWMxxx					
PB0 to PB7	PB0 to PB7/ PWMxxx to PWMxxx					
PC0 to PC3	PC0 to PC3/ PWMxxx to PWMxxx					
PD0	PD0/TIN0/ IN0/PWC0	Input enabled	Input enabled	Input enabled	Hi-Z	Input fixed to "0"
PD1	PD1/TIN1					
PD2	PD2/TIN2					
PD3	PD3/IN3					

(Continued)

# MB91245/S Series

(Continued)

Pin name	Function name	Initial value		In sleep mode	In stop mode	
		$\overline{\text{INIT}} = \text{"L"}$	$\overline{\text{INIT}} = \text{"H"}$		HIZ = 0	HIZ = 1
PD4	PD4/COM0/ PPG1	"L" output	"L" output		P : Immediately preceding status held LCDC : Output or hold PPG : Output held	Input fixed to "0"
PD5	PD5/COM1/ PPG3					
PD6	PD6/COM2/ PPG5					
PD7	PD7/COM3/ PPG7					
PE0 to PE7	PE0 to PE7/ PWMxxx to PWMxxx	Output Hi-Z Input enabled	Output Hi-Z Input enabled	P : Immediately preceding status held F : Normal operation performed	P : Immediately preceding status held F : Output held or Hi-Z	Output Hi-Z / Input fixed to "0"
PF0 to PF7	PF0 to PF7/ AN8 to AN15					
PG0	PG0/ (WOT) / PPG0					
PG1	PG1/TOT0/ PPG2					
PG2	PG2/TOT1/ PPG4					
PG3	PG3/TOT2/ PPG6					

## ■ ELECTRICAL CHARACTERISTICS

### 1. Absolute Maximum Ratings

Parameter	Symbol	Rating		Unit	Remarks
		Min	Max		
Power supply voltage*1	$V_{CC}$	$V_{SS} - 0.3$	$V_{SS} + 6.0$	V	
	$AV_{CC}$	$V_{SS} - 0.3$	$V_{SS} + 6.0$	V	$AV_{CC} = V_{CC}^{*2}$
	$V_{AVRH}$	$V_{SS} - 0.3$	$V_{SS} + 6.0$	V	$AV_{CC} \geq V_{AVRH}$
	$DV_{CC}$	$V_{SS} - 0.3$	$V_{SS} + 6.0$	V	$DV_{CC} = V_{CC}^{*2}$
Input voltage*1	$V_I$	$V_{SS} - 0.3$	$V_{CC} + 0.3$	V	
Output voltage*1	$V_O$	$V_{SS} - 0.3$	$V_{CC} + 0.3$	V	
“L” level maximum output current*3	$I_{OL1}$	—	15	mA	*5
	$I_{OL2}$	—	40	mA	*6
“L” level average output current*4	$I_{OLAV1}$	—	4	mA	*5
	$I_{OLAV2}$	—	30	mA	*6
“L” level total maximum output current	$\Sigma I_{OL1}$	—	120	mA	*5
	$\Sigma I_{OL2}$	—	330	mA	*6
“L” level total average output current	$\Sigma I_{OLAV1}$	—	50	mA	*5
	$\Sigma I_{OLAV2}$	—	240	mA	*6
“H” level maximum output current	$I_{OH1}^{*3}$	—	-15	mA	*5
	$I_{OH2}^{*3}$	—	-40	mA	*6
“H” level average output current	$I_{OHAV1}^{*4}$	—	-4	mA	*5
	$I_{OHAV2}^{*4}$	—	-30	mA	*6
“H” level total maximum output current	$\Sigma I_{OH1}$	—	-120	mA	*5
	$\Sigma I_{OH2}$	—	-330	mA	*6
“H” level total average output current	$\Sigma I_{OHAV1}^{*7}$	—	-50	mA	*5
	$\Sigma I_{OHAV2}^{*7}$	—	-240	mA	*6
Power consumption	$P_D$	—	660	mW	
Operating temperature	$T_A$	-40	+105	°C	MASK ROM product (in single chip operation)
		-40	+105	°C	Flash memory product (in single chip operation)
		-40	+85	°C	MASK ROM/Flash memory product (in external bus operation)
Storage temperature	$T_{stg}$	-55	+150	°C	
+B input standard (Maximum clamp current)	$I_{IH1}$	—	2	mA	Exclusive of dedicated input pins*8
+B input standard (Total maximum clamp current)	$\Sigma I_{IH1}$	—	20	mA	

(Continued)

# MB91245/S Series

*(Continued)*

- \*1 : The parameter is based on  $V_{SS} = AV_{SS} = DV_{SS} = 0.0 \text{ V}$ .
- \*2 : Caution must be taken that  $AV_{CC}$  and  $DV_{CC}$  do not exceed  $V_{CC}$  upon power-on and under other circumstances.
- \*3 : The maximum output current defines the peak current value of each of the corresponding pins.
- \*4 : The average output current defines the average value of the current (100 ms) which passes through each of the corresponding pins. The average value represents a value calculated by multiplying the operating current by the operating rate.
- \*5 : Output other than PA0 to PA3 pins, PB0 to PB7 pins, PC0 to PC3 pins, and PE0 to PE7 pins
- \*6 : (PA0 to PA3 pins, PE0 to PE7 pins) + (PB0 to PB7 pins, PC0 to PC3 pins)  
The SMC pins are divided into two groups (12 pins each) and the value is calculated as the total current per group.
- \*7 : The total average output current defines the average value of the current (100 ms) which passes through all the corresponding pins. The average value represents a value calculated by multiplying the operating current by the operating rate.
- \*8 : +B input standard defines the current value for each of the corresponding pins.

**WARNING:** Semiconductor devices can be permanently damaged by application of stress (voltage, current, temperature, etc.) in excess of absolute maximum ratings. Do not exceed these ratings.

## 2. Recommended Operating Conditions

( $V_{SS} = DV_{SS} = AV_{SS} = 0.0\text{ V}$ )

Parameter	Symbol	Rating		Unit	Remarks
		Min	Max		
Power supply voltage	$V_{CC}$ $AV_{CC}$ $DV_{CC}$	4.5	5.5	V	Recommended guaranteed operating range (MB91F248, MB91248)
		3.5	5.5	V	Guaranteed operating range* <sup>1</sup> (MB91F248, MB91248)
		2.0	5.5	V	Guaranteed operating range for holding stop operation status* <sup>2</sup> (MB91F248, MB91248)
Smoothing capacitor* <sup>3</sup>	$C_S$	1		$\mu\text{F}$	Use a ceramic capacitor or a capacitor with similar frequency characteristics.
Operating temperature	$T_A$	-40	+105	$^{\circ}\text{C}$	MASK ROM product (in single chip operation)
		-40	+105	$^{\circ}\text{C}$	Flash memory product (in single chip operation)
		-40	+85	$^{\circ}\text{C}$	MASK ROM/Flash memory product (in external bus operation)

\*1 : Exclusive of A/D operation

\*2 : Internal voltage held in RAM : 1.8 V (Min) /3.6 V (Max)

\*3 : For how to connect the smoothing capacitor  $C_S$ , refer to the figure below.

### • C Pin Connection Diagram

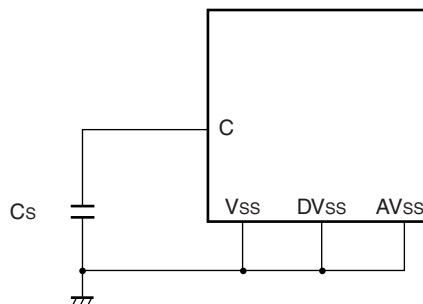

### < + B input (12 V to 16 V) conditions >

- Do not connect +B potential directly to a microcontroller pin.
- Always connect a resistor between the microcontroller pin and +B signal to limit the current.

$I_{HH} = 2\text{ mA}$  per pin (Max.) [In the steady state and transient state between power-on and power-off, etc.]

It can be connected to any general-purpose input port except the output pin for LCDC.

- The protection diode in the microcontroller turns the potential upon +B input between the limiting resistor and microcontroller pin into " $V_{CC} +$  protection diode ON voltage". Configure the circuit so that these are not interfered and the potential is not exceeded.

# MB91245/S Series

## Recommended example circuit

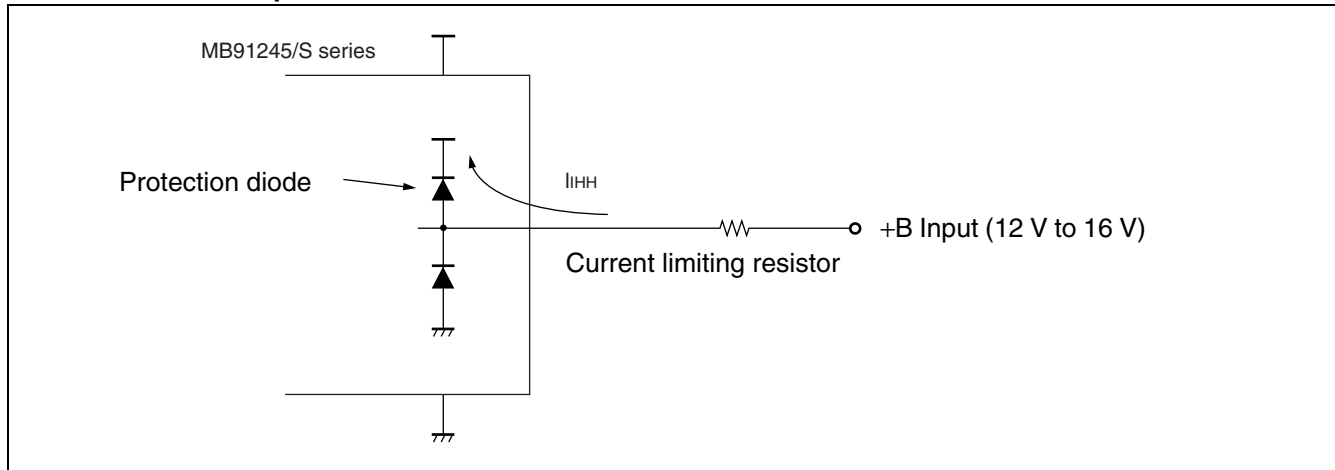

**WARNING:** The recommended operating conditions are required in order to ensure the normal operation of the semiconductor device. All of the device's electrical characteristics are warranted when the device is operated within these ranges.

Always use semiconductor devices within their recommended operating condition ranges. Operation outside these ranges may adversely affect reliability and could result in device failure.

No warranty is made with respect to uses, operating conditions, or combinations not represented on the data sheet. Users considering application outside the listed conditions are advised to contact their FUJITSU representatives beforehand.



# MB91245/S Series

## 3. DC Specifications

(T<sub>A</sub> : Recommended operating conditions; V<sub>CC</sub> = 5.0 V ±10%, V<sub>SS</sub> = DV<sub>SS</sub> = AV<sub>SS</sub> = 0.0 V)

Parameter	Symbol	Pin name	Condition	Value			Unit	Remarks
				Min	Typ	Max		
“H” level input voltage	V <sub>IHS</sub>	—	—	0.8 V <sub>CC</sub>	—	V <sub>CC</sub> + 0.3	V	Automotive level input pins* <sup>1</sup>
	V <sub>IH</sub>	P00 to P07, P10 to P17, P57	—	0.7 V <sub>CC</sub>	—	V <sub>CC</sub> + 0.3	V	CMOS hysteresis input pins* <sup>2</sup>
	V <sub>IHM</sub>	—	—	V <sub>CC</sub> - 0.3	—	V <sub>CC</sub> + 0.3	V	MOD pins* <sup>3</sup>
	V <sub>IHX</sub>	X0, X1, X0A, X1A, INIT	—	0.8 V <sub>CC</sub>	—	—	V	
“L” level input voltage	V <sub>ILS</sub>	—	—	V <sub>SS</sub> - 0.3	—	0.5 V <sub>CC</sub>	V	Automotive level input pins* <sup>1</sup>
	V <sub>IL</sub>	P00-P07, P10-P17, P57	—	V <sub>SS</sub> - 0.3	—	0.3 V <sub>CC</sub>	V	CMOS hysteresis input pins* <sup>2</sup>
	V <sub>ILM</sub>	—	—	V <sub>SS</sub> - 0.3	—	V <sub>SS</sub> + 0.3	V	MOD pins* <sup>3</sup>
	V <sub>ILX</sub>	X0, X1, X0A, X1A, INIT	—	—	—	0.2 V <sub>CC</sub>	V	
Power supply current* <sup>4</sup>	I <sub>CC</sub>	V <sub>CC</sub>	Operating frequency : F <sub>CP</sub> = 32 MHz in main mode	—	55	85	mA	Flash memory product
				—	55	85	mA	MASK ROM product
				—	100	150	mA	In Flash-Write mode
	I <sub>CCL</sub>		Operating frequency : F <sub>CP</sub> = 32 kHz, T <sub>A</sub> = +25 °C in sub mode	—	290	450	μA	
	I <sub>CCH</sub>		T <sub>A</sub> = +25 °C, V <sub>CC</sub> = 5V in stop mode (oscillation stopped)	—	95	150	μA	
I <sub>CTS</sub>	T <sub>A</sub> = +25 °C, V <sub>CC</sub> = 5V in stop mode (RTC in use)	—	390	500	μA	At 4 MHz		
Input leak current	I <sub>IL</sub>	All input pins	V <sub>CC</sub> = DV <sub>CC</sub> = AV <sub>CC</sub> = 5.5 V V <sub>SS</sub> < V <sub>I</sub> < V <sub>CC</sub>	-5	—	+5	μA	
Input capacity 1	C <sub>IN1</sub>	Other than V <sub>CC</sub> , V <sub>SS</sub> , DV <sub>CC</sub> , DV <sub>SS</sub> , AV <sub>CC</sub> , AV <sub>SS</sub> , PA0 to PA3, PB0 to PB7, PC0 to PC3, PE0 to PE7	—	—	5	15	pF	
Input capacity 2	C <sub>IN2</sub>	PA0 to PA3, PB0 to PB7, PC0 to PC3, PE0 to PE7	—	—	15	45	pF	
Pull-up resistance	R <sub>UP</sub>	INIT	—	25	50	100	kΩ	

(Continued)

# MB91245/S Series

(Continued)

( $T_A$  : Recommended operating conditions;  $V_{CC} = 5.0\text{ V} \pm 10\%$ ,  $V_{SS} = DV_{SS} = AV_{SS} = 0.0\text{ V}$ )

Parameter	Symbol	Pin name	Condition	Value			Unit	Remarks
				Min	Typ	Max		
Pull-down resistance	$R_{DOWN}$	MOD1, MOD2	—	25	50	100	k $\Omega$	MASK ROM products only
Output “H” voltage 1	$V_{OH1}$	Other than PA0 to PA3, PB0 to PB7, PC0 to PC3, PE0 to PE7	$V_{CC} = 4.5\text{ V}$ $I_{OH} = -4.0\text{ mA}$	$V_{CC} - 0.5$	—	—	V	
Output “H” voltage 2	$V_{OH2}$	PA0 to PA3, PB0 to PB7, PC0 to PC3, PE0 to PE7	$V_{CC} = 4.5\text{ V}$ $I_{OH} = -30.0\text{ mA}$	$V_{CC} - 0.5$	—	—	V	
Output “L” voltage 1	$V_{OL1}$	Other than PA0 to PA3, PB0 to PB7, PC0 to PC3, PE0 to PE7	$V_{CC} = 4.5\text{ V}$ $I_{OL} = 4.0\text{ mA}$	—	—	0.4	V	
Output “L” voltage 2	$V_{OL2}$	PA0 to PA3, PB0 to PB7, PC0 to PC3, PE0 to PE7	$V_{CC} = 4.5\text{ V}$ $I_{OL} = 30.0\text{ mA}$	—	—	0.55	V	
High current output Drive capacity Phase-to-phase deviation 1	$\Delta V_{OH2}$	PWM1Pn, PWM1Mn, PWM2Pn, PWM2Mn, n = 0 to 5	$V_{CC} = 4.5\text{ V}$ $I_{OH} = 30.0\text{ mA}$ Maximum deviation of $V_{OH2}$	0	—	90	mV	*5
High current output Drive capacity Phase-to-phase deviation 2	$\Delta V_{OL2}$	PWM1Pn, PWM1Mn, PWM2Pn, PWM2Mn, n = 0 to 5	$V_{CC} = 4.5\text{ V}$ $I_{OL} = 30.0\text{ mA}$ Maximum deviation of $V_{OL2}$	0	—	90	mV	*5
COM0 to COM3 Output impedance	$R_{VCOM}$	COMm (m = 0 to 3)	—	—	—	2.5	k $\Omega$	
SEG00 to SEG31 Output impedance	$R_{VSEG}$	SEGn (n = 00 to 31)	—	—	15	30	k $\Omega$	
LCDC leak current	$I_{LCDC}$	COMm (m = 0 to 3), SEGn, (n = 00 to 31)	$T_A = +25\text{ }^\circ\text{C}$	-0.5	—	+0.5	$\mu\text{A}$	

\*1 : All input pins except X0, X1, X0A, X1A, MOD0, MOD1, MOD2 and  $\overline{INIT}$  pins

\*2 : Can be selected by the input level select register (PILR).

\*3 : MOD0, MOD1 and MOD2

\*4 : They represent current values used when supplying power to the external clock from pin X1.

\*5 : Defined by the maximum deviation of  $V_{OH2}/V_{OL2}$  of each pin, when PWM1P0, PWM1M0, PWM2P0 and PWM2M0 in ch.0 are simultaneously turned on. The same applies to other channels.

## 4. Flash Memory Write/Erase Characteristics

Parameter	Condition	Value			Unit	Remarks
		Min	Typ	Max		
Sector erase time	T <sub>A</sub> = +25 °C, V <sub>CC</sub> = 5.0 V	—	1	15	s	Exclusive of internal write time prior to erase
Chip erase time	T <sub>A</sub> = +25 °C, V <sub>CC</sub> = 5.0 V	—	5	—	s	Exclusive of internal write time prior to erase
Halfword write time	T <sub>A</sub> = +25 °C, V <sub>CC</sub> = 5.0 V	—	16	3600	μs	Exclusive of overhead time at system level
Chip write time	T <sub>A</sub> = +25 °C, V <sub>CC</sub> = 5.0 V	—	2.1	—	s	Exclusive of overhead time at system level
Erase/write cycle	—	10000	—	—	cycle	
Flash memory data retain time	T <sub>A</sub> = +85 °C (average)	10	—	—	year	*

\* : This value comes from the technology qualification (using Arrhenius equation to translate high temperature measurements into normalized value at + 85 °C) .

# MB91245/S Series

## 5. AC Specifications

### (1) Clock timing

(T<sub>A</sub> : Recommended operating conditions; V<sub>CC</sub> = 5.0 V ±10%, V<sub>SS</sub> = DV<sub>SS</sub> = AV<sub>SS</sub> = 0.0 V)

Parameter	Symbol	Pin name	Condition	Value			Unit	Remarks
				Min	Typ	Max		
Frequency of source oscillation clock	F <sub>C</sub>	X0, X1	—	—	4	—	MHz	
	F <sub>ca</sub>	X0A, X1A		—	32	—	kHz	
Source oscillation clock Cycle time	t <sub>CYL</sub>	X0, X1	—	—	250	—	ns	
Input clock pulse width	P <sub>WH</sub> , P <sub>WL</sub>	X0	—	100	—	—	ns	The duty ratio normally ranges from 40% to 60%.
Frequency of internal operating clock	f <sub>CPB</sub>	—	—	0.0312	—	32	MHz	CPU based (CLKB)
	f <sub>CPT</sub>			0.0312	—	16	MHz	External bus based (CLKT)
	f <sub>CPP</sub>			0.0312	—	32	MHz	Peripheral based (CLKP)
Internal operating clock cycle	t <sub>CPB</sub>	—	—	31.25	—	32000	ns	CPU based (CLKB)
	t <sub>CPT</sub>			62.5	—	32000	ns	External bus based (CLKT)
	t <sub>CPP</sub>			31.25	—	32000	ns	Peripheral based (CLKP)
Input clock Rise/fall time	t <sub>cr</sub> t <sub>cf</sub>	X0	—	—	—	5	ns	When external clock is used
Frequency of internal base clock	F <sub>CP</sub>	—		—	—	32	MHz	When main oscillation is at 4 MHz and PLL multiplied by 8 is used
Internal base clock Cycle time	t <sub>CP</sub>	—	—	31.25	—	—	ns	When main oscillation is at 4 MHz and PLL multiplied by 8 is used

#### • X0/X1 Clock Timing

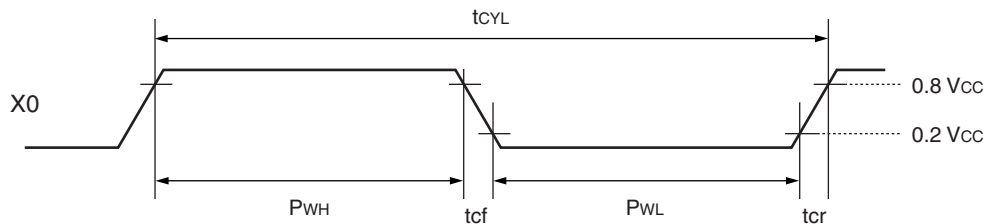

- Operations

Oscillation should be performed as described below :

[Source oscillation] : X0/X1 : 4 MHz, PLL : multiplied by 8, Internal frequency : 32 MHz

: X0A/X1A : 32 kHz, PLL : no multiplied, Internal frequency : 32 kHz

Note that the PLL oscillation stabilization wait time should be set to 500  $\mu$ s or more.

Example oscillation circuit

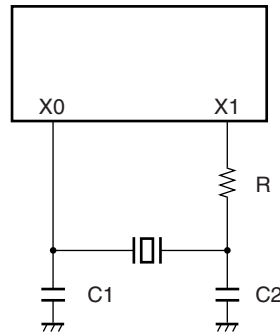

AC specifications are defined by the following measurement standard voltage values :

- Input signal waveform

Hysteresis input pin

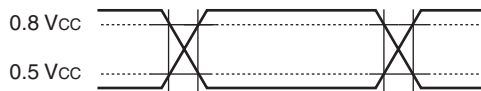

- Output signal waveform

Output pin

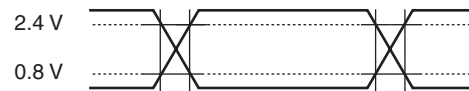

# MB91245/S Series

## (2) Reset input

(T<sub>A</sub> : Recommended operating conditions; V<sub>CC</sub> = 5.0 V ±10%, V<sub>SS</sub> = DV<sub>SS</sub> = AV<sub>SS</sub> = 0.0 V)

Parameter	Symbol	Pin name	Condition	Value		Unit	Remarks
				Min	Max		
$\overline{\text{INIT}}$ input time	t <sub>INTL</sub>	$\overline{\text{INIT}}$	—	500	—	ns	Flash memory product
				10 t <sub>CP</sub>	—	ns	MASK ROM product
				Oscillation time of oscillator* + 10 t <sub>CP</sub> + 12 μs	—	ms	In stop mode

\* : The oscillation time of the oscillator refers to the time when the amplitude has reached 90%. The oscillation time of the crystal oscillator ranges from several ms to tens of ms. The oscillation time of the ceramic oscillator ranges from several hundreds to several ms, while that of the external clock is 0 ms.

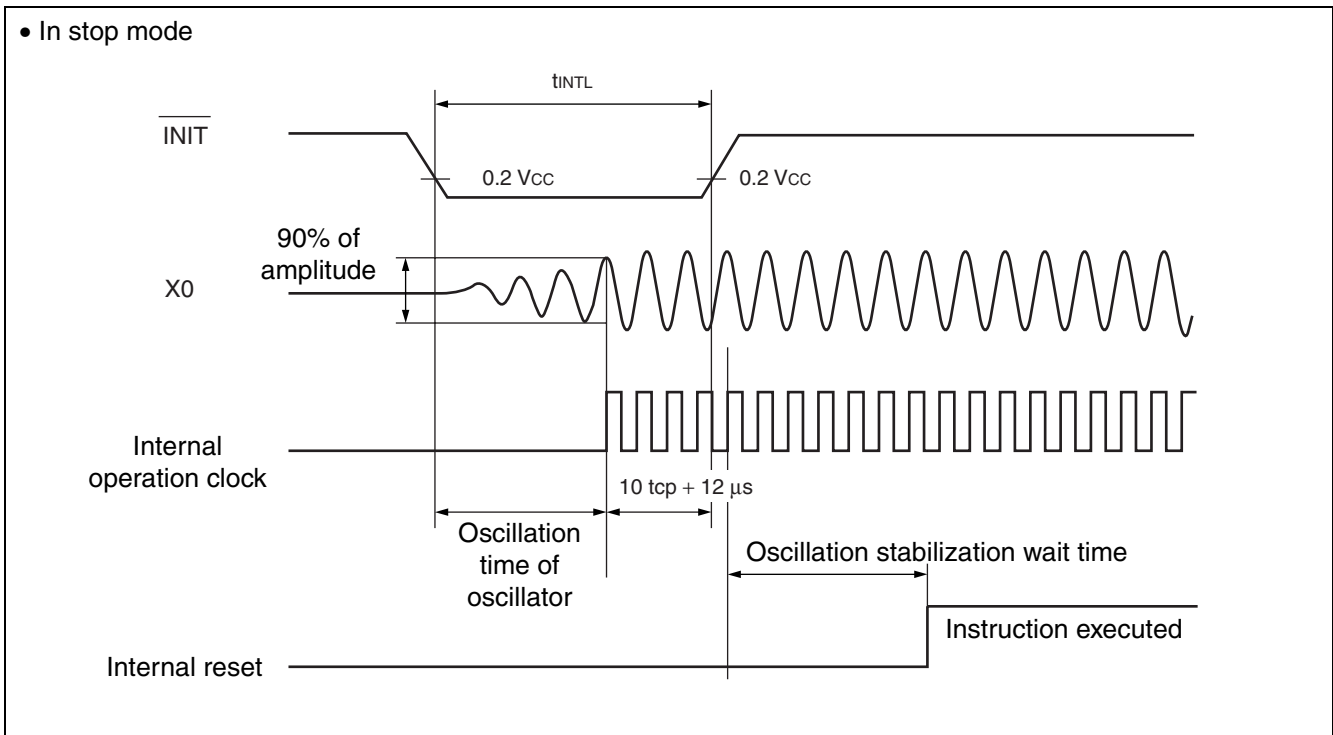
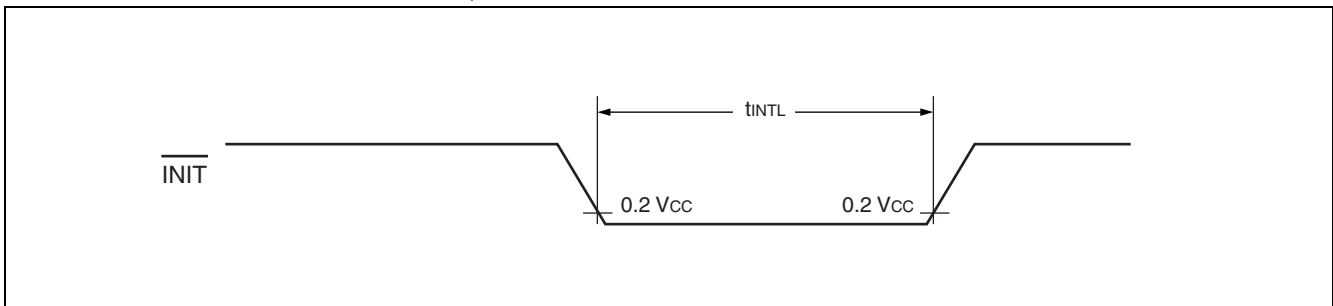

## [External reset input specifications ( $\overline{\text{INIT}}$ ) and internal reset signal cancellation timing]

- When an external reset input is generated, a maximum of 256 tcp is designed to be spent until it reaches the internal reset signal to transmit all reset signals to the internal logic.  
(Max 8  $\mu\text{s}$  at 32 MHz)
- The following chart shows how to set the timing for instruction execution start (start of application operation) after external reset input.

Time from external reset input to instruction start = Max 256 tcp + 61 tcp

### • Timing Chart

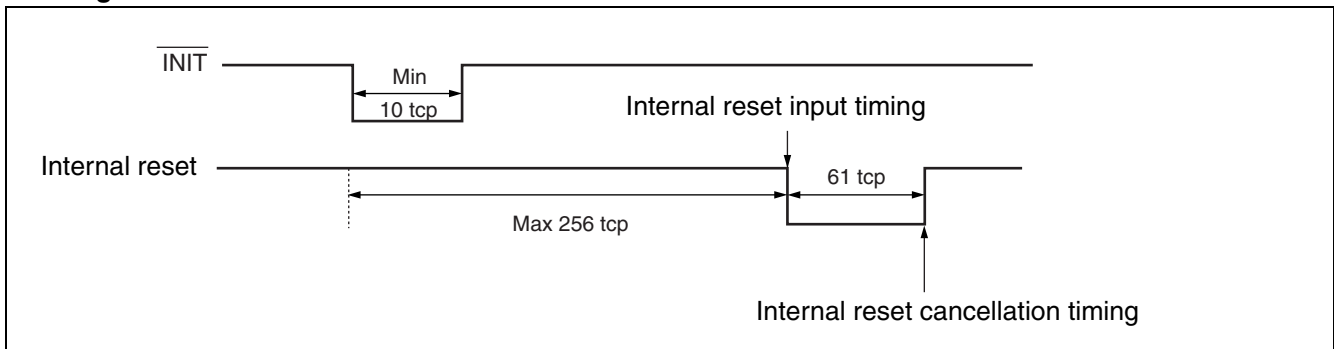

### [Pin state in external bus mode]

In the external bus mode, it is not guaranteed to hold the RAM value upon external reset ( $\overline{\text{INIT}} = "0"$ ) input.

In the external bus mode, the value of the internal bus is output to each pin during the time from the internal reset input to its cancellation as well as the RAM value is not guaranteed to be held.

### • Timing Chart (Pin State for External Bus Mode : 1)

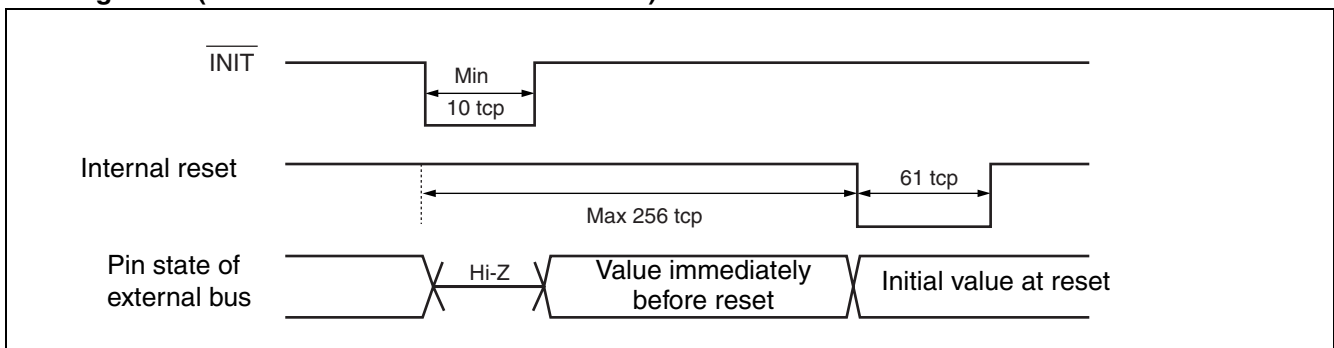

# MB91245/S Series

It can be avoided by the following external reset input to continue Hi-Z.

## • Timing Chart (Pin State for External Bus Mode : 2)

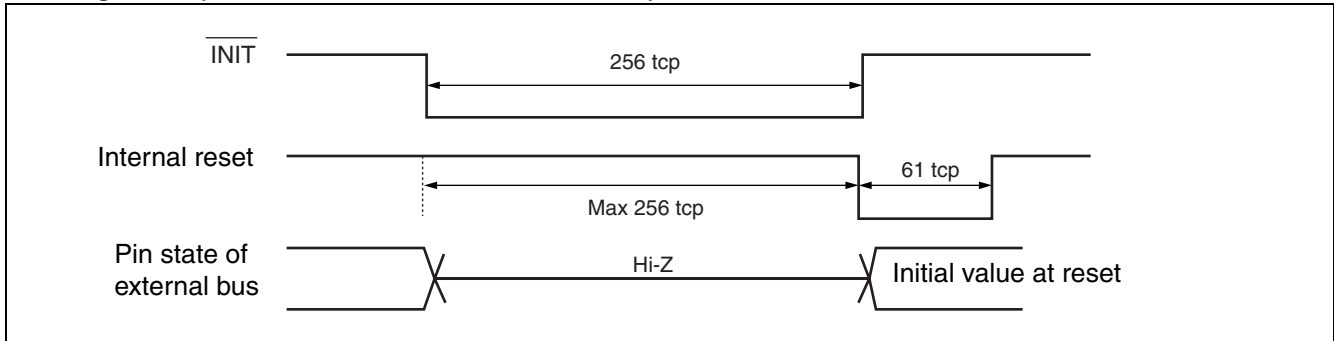



### (3) Power-on Conditions

(T<sub>A</sub> : Recommended operating conditions; V<sub>SS</sub> = 0.0 V)

Parameter	Symbol	Pin name	Condition	Value		Unit	Remarks
				Min	Max		
Power supply rising time	t <sub>R</sub>	V <sub>CC</sub>	—	0.05	30	ms	
Power supply start voltage	V <sub>OFF</sub>			—	0.2	V	
Power supply peak voltage	V <sub>ON</sub>			3.5	—	V	
Power supply cut-off time	t <sub>OFF</sub>			50	—	ms	Due to repetitive operation

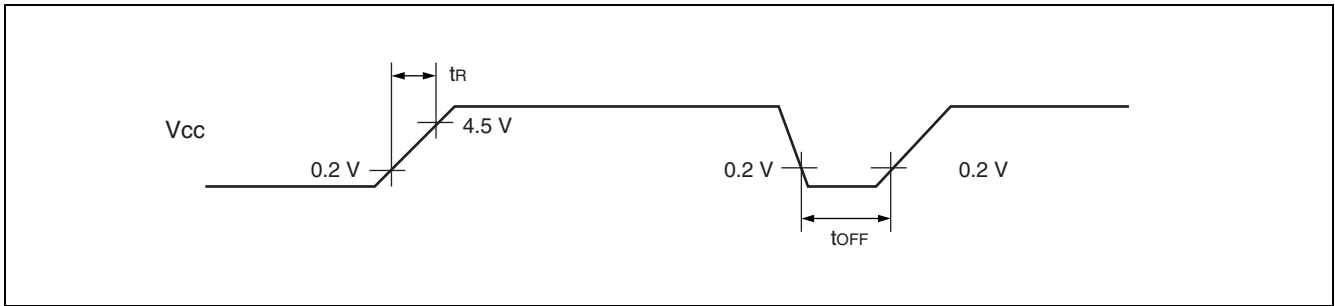

Power supply drop time, power supply voltages and external reset input to retain RAM data in MB91245/S  
Satisfy the following reset input standard to retain the RAM data used in the single chip mode.

V <sub>CC</sub> (V)	Voltage drop time	External reset input standard ( $\overline{\text{INIT}}$ )
4.0 V → 3.5 V dropped	Min 256 tcp	Min 256 tcp

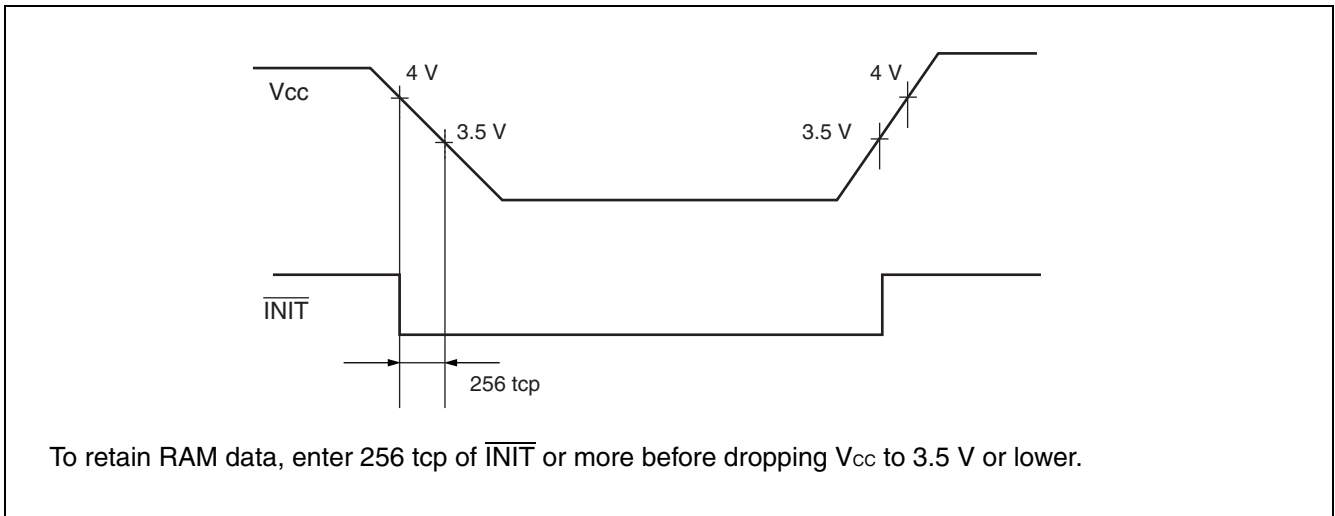

To retain RAM data, enter 256 tcp of  $\overline{\text{INIT}}$  or more before dropping V<sub>CC</sub> to 3.5 V or lower.

# MB91245/S Series

## (4) Clock Output Timing

( $V_{CC} = 4.5\text{ V to }5.5\text{ V}$ ,  $V_{SS} = AV_{SS} = 0\text{ V}$ )

Parameter	Symbol	Pin name	Condition	Value		Unit	Remarks
				Min	Max		
Cycle time	$t_{CYC}$	SYSCLK	—	$t_{CPT}$	—	ns	*1
SYSCLK $\uparrow$ →SYSCLK $\downarrow$	$t_{CHCL}$	SYSCLK		$t_{CYC} / 2 - 10$	$t_{CYC} / 2 + 10$	ns	*2
SYSCLK $\downarrow$ →SYSCLK $\uparrow$	$t_{CLCH}$	SYSCLK		$t_{CYC} / 2 - 10$	$t_{CYC} / 2 + 10$	ns	*3

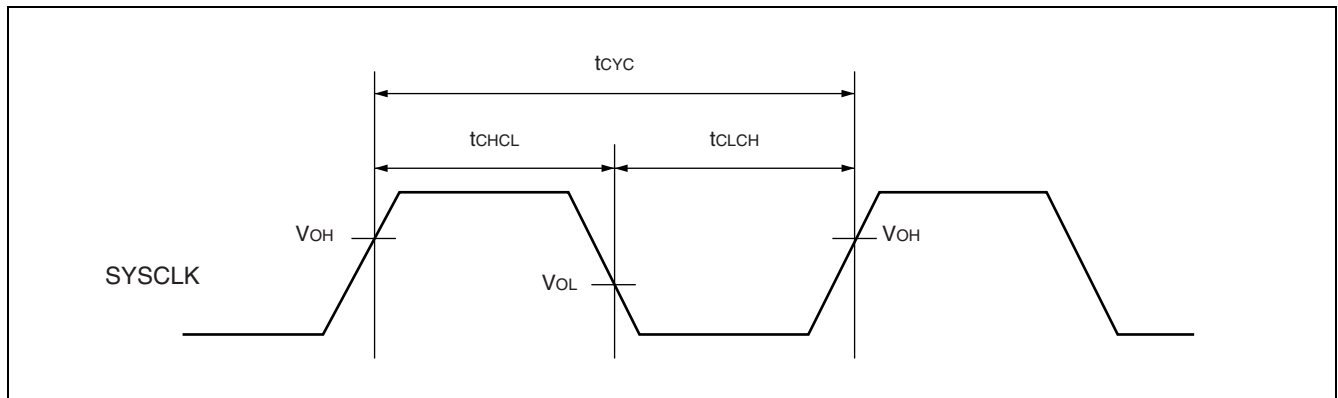

\*1 :  $t_{CYC}$  is the frequency of one clock cycle including the gear cycle.

\*2 : The ratings are based on conditions with “gear cycle  $\times 1$ ”.

When the gear cycle is set to 1/2, 1/4 or 1/8, perform calculation by substituting 1/2, 1/4 or 1/8 for “n” in the following formula, respectively.

$$(1/2 \times 1/n) \times t_{CYC} - 10$$

\*3 : This is the value for the gear cycle  $\times 1$ .

## (5) Normal Bus Access : Read/Write Operation

(V<sub>CC</sub> = 4.0 V to 5.5 V, V<sub>SS</sub> = AV<sub>SS</sub> = 0 V, T<sub>A</sub> = 0 °C to + 70 °C)

Parameter	Symbol	Pin name	Condition	Value		Unit	Remarks
				Min	Max		
$\overline{CS0}$ to $\overline{CS3}$ setup	t <sub>CSLCH</sub>	SYSCLK $\overline{CS0}$ to $\overline{CS3}$	AWRxL : W02 = 0	3	—	ns	
	t <sub>CSDLCH</sub>		AWRxL : W02 = 1	-8	—	ns	
$\overline{CS0}$ to $\overline{CS3}$ hold	t <sub>CHCSH</sub>			3	t <sub>CYC</sub> / 2 + 25	ns	
Address setup	t <sub>ASCH</sub>	SYSCLK A00 to A15		3	—	ns	
	t <sub>ASWL</sub>	$\overline{WR0}$ , $\overline{WR1}$ A00 to A15		3	—	ns	
	t <sub>ASRL</sub>	$\overline{RD}$ A00 to A15		3	—	ns	
Address hold	t <sub>CHAX</sub>	SYSCLK A00 to A15		3	t <sub>CYC</sub> / 2 + 25	ns	
	t <sub>WHAX</sub>	$\overline{WR0}$ , $\overline{WR1}$ A00 to A15		3	—	ns	
	t <sub>RHAX</sub>	$\overline{RD}$ A00 to A15		3	—	ns	
Valid address → valid data input time	t <sub>AVDV</sub>	A00 to A15 D00 to D15		—	3 / 2 × t <sub>CYC</sub> + 45	ns	*1, *2
$\overline{WR0}$ , $\overline{WR1}$ delay time	t <sub>CHWL</sub>	SYSCLK $\overline{WR0}$ , $\overline{WR1}$	—	—	8	ns	
$\overline{WR0}$ , $\overline{WR1}$ delay time	t <sub>CHWH</sub>			—	8	ns	
$\overline{WR0}$ , $\overline{WR1}$ minimum pulse width	t <sub>WLWH</sub>	$\overline{WR0}$ , $\overline{WR1}$		t <sub>CYC</sub> - 5	—	ns	
$\overline{WR0}$ , $\overline{WR1}$ ↑ → data hold time	t <sub>WHDX</sub>	D00 to D15		3	—	ns	
$\overline{RD}$ delay time	t <sub>CHRL</sub>	SYSCLK		—	6	ns	
$\overline{RD}$ delay time	t <sub>CHRH</sub>	$\overline{RD}$		—	6	ns	
$\overline{RD}$ ↓ → valid data input time	t <sub>RLDV</sub>	$\overline{RD}$ D00 to D15		—	t <sub>CYC</sub> - 30	ns	*1
Data setup → $\overline{RD}$ ↑ time	t <sub>DSRH</sub>			20	—	ns	
$\overline{RD}$ ↑ → data hold time	t <sub>RHDX</sub>			0	—	ns	
$\overline{RD}$ minimum pulse width	t <sub>RLRH</sub>	$\overline{RD}$		t <sub>CYC</sub> - 5	—	ns	
$\overline{AS}$ setup	t <sub>ASLCH</sub>	SYSCLK		3	—	ns	
$\overline{AS}$ hold	t <sub>CHASH</sub>	$\overline{AS}$		3	t <sub>CYC</sub> / 2 + 25	ns	

\*1 : If the bus is expanded by automatic wait insertion or RDY input, add time (t<sub>CYC</sub> × the number of expanded cycles) to the rated value.

\*2 : The ratings are based on conditions with "gear cycle × 1". If the gear cycle is set to 1/2 to 1/16, perform calculation by substituting the corresponding value for "n" in the following formula.

$$\text{Formula : } 3 / (2n) \times t_{CYC} + 45$$

# MB91245/S Series

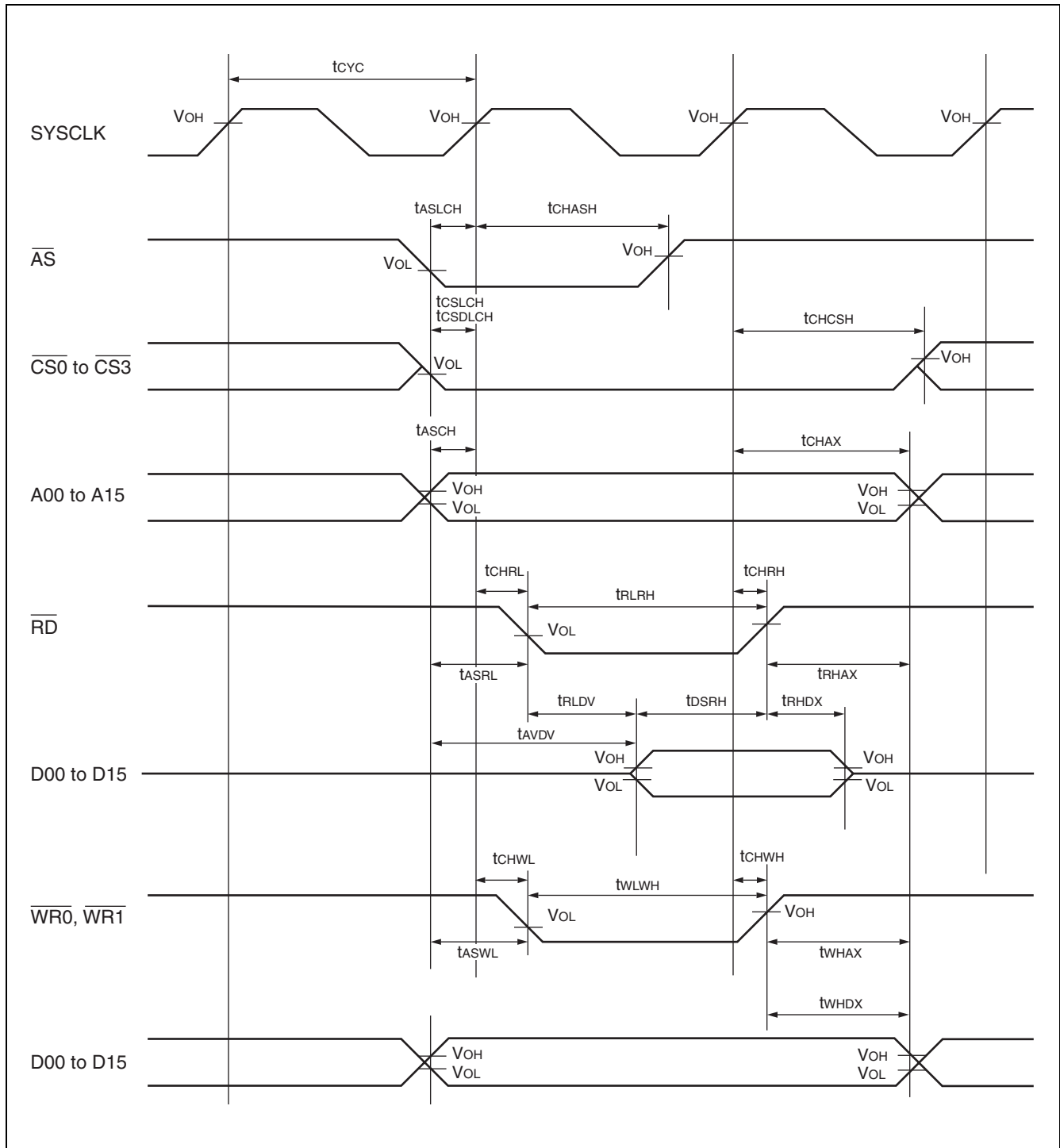

## (6) Ready Input Timing

( $V_{CC} = 4.5\text{ V to }5.5\text{ V}$ ,  $V_{SS} = AV_{SS} = 0\text{ V}$ )

Parameter	Symbol	Pin name	Condition	Value		Unit	Remarks
				Min	Max		
RDY setup time →SYSCLK↓	$t_{RDYS}$	SYSCLK RDY	—	10	—	ns	
SYSCLK↑→ RDY hold time	$t_{RDYH}$	SYSCLK RDY		0	—	ns	

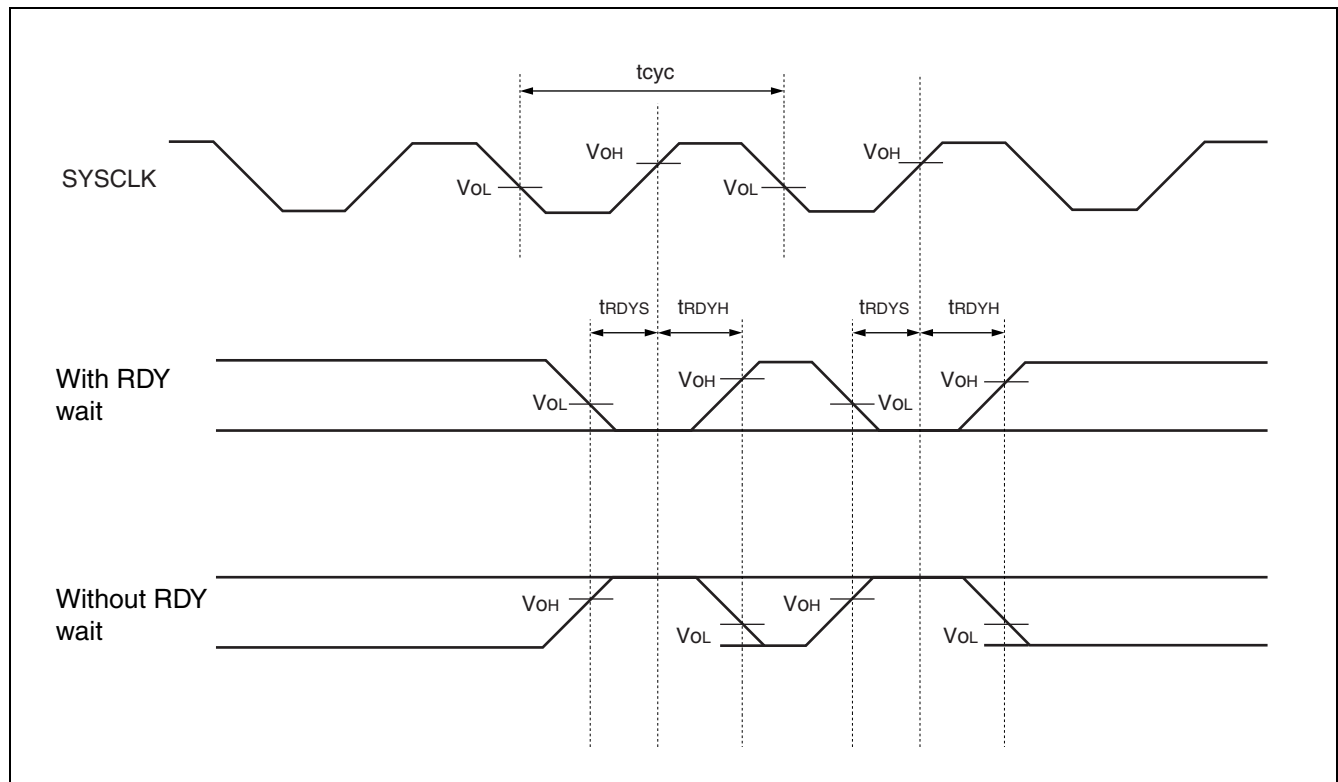

# MB91245/S Series

## (7) UART Timing

(T<sub>A</sub> : Recommended operating conditions; V<sub>CC</sub> = 5.0 V ±10%, V<sub>SS</sub> = AV<sub>SS</sub> = 0.0 V)

Parameter	Symbol	Pin name	Condition	Value		Unit	Remarks
				Min	Max		
Serial clock Cycle time	t <sub>SCYC</sub>	SCK0	—	8 t <sub>CP</sub>	—	ns	For internal shift clock mode output pin, C <sub>L</sub> = 80 pF+1·TTL
SCK↓→ SOT delay time	t <sub>SLOV</sub>	SCK0, SOT0		-80	+80	ns	
Valid SIN→ SCK↑	t <sub>IVSH</sub>	SCK0, SIN0		100	—	ns	
SCK↑→ Valid SIN hold time	t <sub>SHIX</sub>			60	—	ns	
Serial clock “H” pulse width	t <sub>SHSL</sub>	SCK0	—	4 t <sub>CP</sub>	—	ns	For external shift clock mode output pin, C <sub>L</sub> = 80 pF+1·TTL
Serial clock “L” pulse width	t <sub>SLSH</sub>			4 t <sub>CP</sub>	—	ns	
SCK↓→ SOT delay time	t <sub>SLOV</sub>	SCK0, SOT0		—	150	ns	
Valid SIN→ SCK↑	t <sub>IVSH</sub>	SCK0, SIN0		60	—	ns	
SCK↑→ Valid SIN hold time	t <sub>SHIX</sub>			60	—	ns	

- Notes :
- The above ratings are the values for clock synchronous mode.
  - C<sub>L</sub> is a load capacitance connected to pins during testing.

- Internal Shift Clock Mode

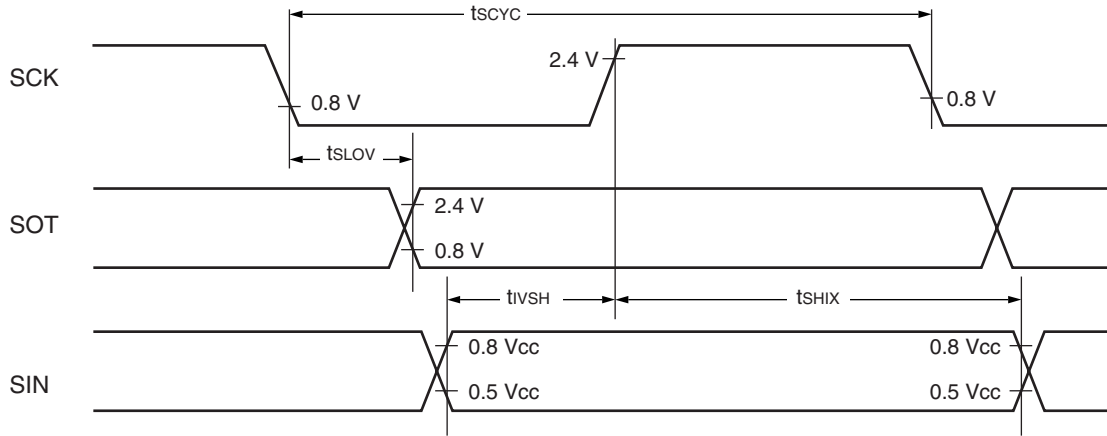

- External Shift clock Mode

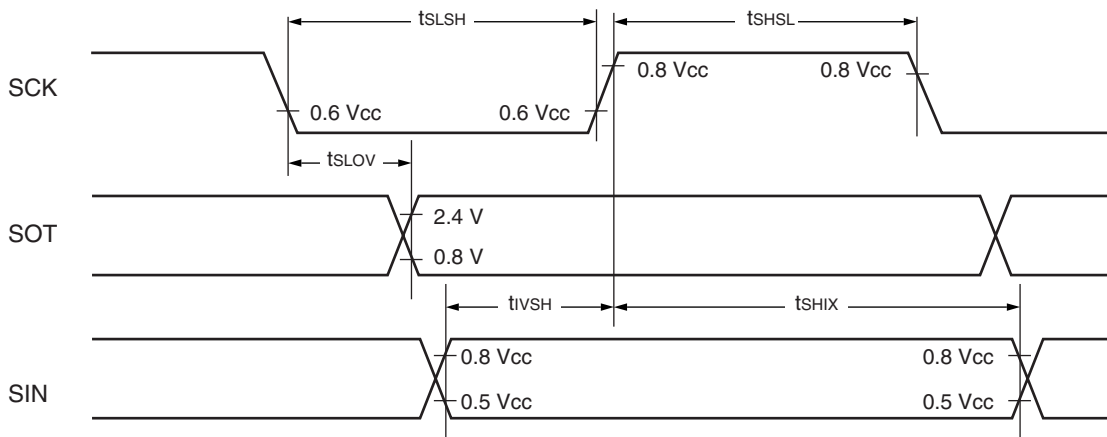

# MB91245/S Series

## (8) Timer Input Timing

(T<sub>A</sub> : Recommended operating conditions; V<sub>CC</sub> = 5.0 V ±10%, V<sub>SS</sub> = AV<sub>SS</sub> = 0.0 V)

Parameter	Symbol	Pin name	Condition	Value		Unit	Remarks
				Min	Max		
Input pulse width	t <sub>TIWH</sub> t <sub>TIWL</sub>	TIN0 to TIN2, PWC IN0 to IN3	—	4 t <sub>CP</sub>	—	ns	

### • Timer Input Timing

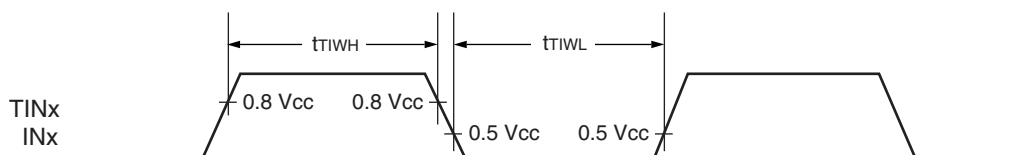

## (9) External Interrupt Timing

(T<sub>A</sub> : Recommended operating conditions; V<sub>CC</sub> = 5.0 V ±10%, V<sub>SS</sub> = AV<sub>SS</sub> = 0.0 V)

Parameter	Symbol	Pin name	Condition	Value		Unit	Remarks
				Min	Max		
Input pulse width	t <sub>INTH</sub> , t <sub>INTL</sub>	INT0 to INT7	—	3 t <sub>CP</sub>	—	ns	

### • External interrupt input timing

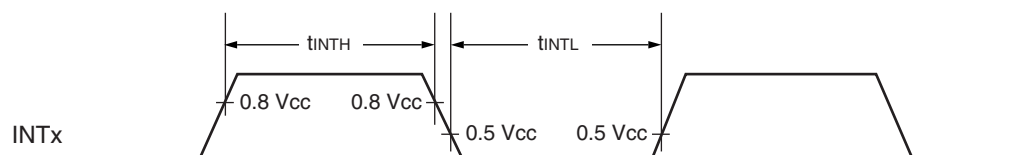

Note : For INT<sub>x</sub> level detection time required to recover from the stop mode, add the stabilization time for the internal step-down circuit (12 μs).



## 6. A/D Converter Electrical Characteristics

### (1) Electrical Characteristics

(T<sub>A</sub> : Recommended operating conditions; V<sub>CC</sub> = AV<sub>CC</sub> = 5.0 V ±10%, V<sub>SS</sub> = AV<sub>SS</sub> = 0.0 V)

Parameter	Symbol	Pin name	Value			Unit	Remarks
			Min	Typ	Max		
Resolution	—	—	—	—	10	bit	
Total error	—	—	—	—	±3.0	LSB	
Non-linearity error	—	—	—	—	±2.5	LSB	
Differential linearity error	—	—	—	—	±1.9	LSB	
Zero transition voltage	V <sub>OT</sub>	AN0 to AN31	AV <sub>SS</sub> − 1.5 LSB	AV <sub>SS</sub> + 0.5 LSB	AV <sub>SS</sub> + 2.5 LSB	V	1 LSB = (AV <sub>RH</sub> − AV <sub>SS</sub> ) / 1024
Full-scale transition voltage	V <sub>FST</sub>	AN0 to AN31	AV <sub>RH</sub> − 3.5 LSB	AV <sub>RH</sub> − 1.5 LSB	AV <sub>RH</sub> + 0.5 LSB	V	
Sampling time	t <sub>SMP</sub>	—	1.375	—	—	μs	*1
Compare time	t <sub>CMP</sub>	—	1.375	—	—	μs	*2
A/D conversion time	t <sub>CNV</sub>	—	2.750	—	—	μs	*3
Analog port input current	I <sub>AIN</sub>	AN0 to AN31	—	—	10	μA	V <sub>AVSS</sub> ≤ V <sub>AIN</sub> ≤ V <sub>AVCC</sub>
Analog input voltage	V <sub>AIN</sub>	AN0 to AN31	0	—	AV <sub>RH</sub>	V	
Standard voltage	AVR +	AVRH	4.0	—	AV <sub>CC</sub>	V	
Power supply current*4	I <sub>A</sub>	AV <sub>CC</sub>	—	2.4	4.7	mA	
	I <sub>AH</sub>		—	—	5	μA	*5
Standard voltage supply current	I <sub>R</sub>	AVRH	—	500	900	μA	V <sub>AVRH</sub> = 5.0 V
	I <sub>RH</sub>	AVRH	—	—	5	μA	*5
Variation between channels	—	AN0 to AN31	—	—	5	LSB	

\*1 : When F<sub>CP</sub> is 32 MHz : t<sub>SMP</sub> = (R<sub>ext</sub> + R<sub>in</sub>) × C<sub>in</sub> × 7 = ST × CLKP cycle = 2 channels × 31.25 ns = 1.375 μs

\*2 : When F<sub>CP</sub> is 32 MHz : t<sub>CMP</sub> = CKIN × 11 = CT × CLKP cycle × 11 = 4 h × 31.25 ns × 11 = 1.375 μs

\*3 : This represents the conversion time per channel when t<sub>SMP</sub> and t<sub>CMP</sub> are selected while F<sub>CP</sub> is 32 MHz.

\*4 : The current values are targeted temporary ratings.

\*5 : This defines the power supply current when the A/D converter is not in operation and the CPU is stopped (at “V<sub>CC</sub> = AV<sub>CC</sub> = AV<sub>RH</sub> = 5.0 V”)

Notes : • As AV<sub>RH</sub> becomes smaller, the error becomes greater.

- Use the output impedance r<sub>s</sub> of the external circuit for analog input under the following conditions :  
Output impedance r<sub>s</sub> of the external circuit = 5 kΩ (Max)

- If the output impedance of the external circuit is too high, the sampling time of the analog voltage may not be sufficient.

When placing a DC blocking capacitor between the external circuit and input pin, set the capacitance to the value calculated by multiplying C<sub>SH</sub> by several thousands as a guideline in order to minimize the impact from dividing voltage capacitance with C<sub>SH</sub>.

# MB91245/S Series

## • Analog Input Equivalent Circuit

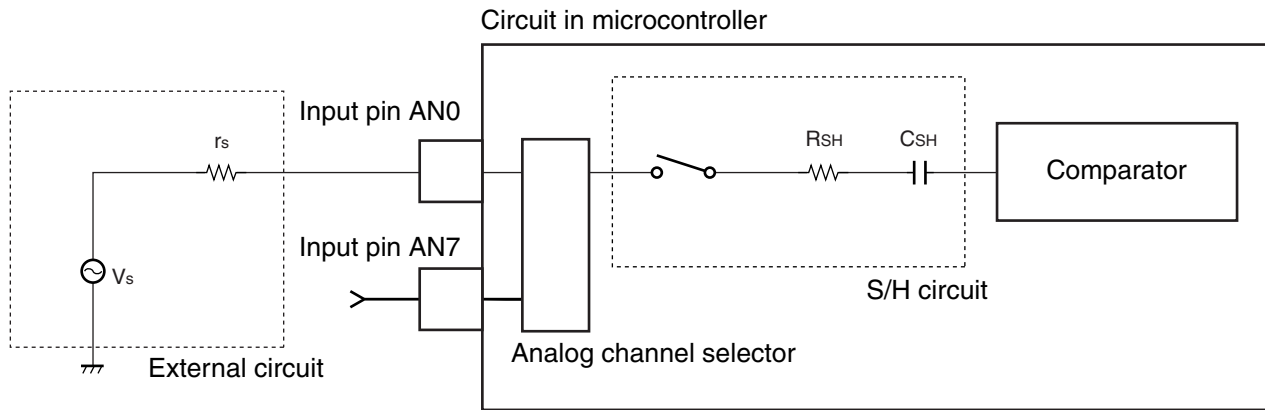

<Recommended parameter values and tentative guideline for each element>

$r_s = 5 \text{ k}\Omega$  or less

$R_{SH} = \text{approx. } 2.5 \text{ k}\Omega$

$C_{SH} = \text{approx. } 10 \text{ pF}$

Note : These element parameters should be regarded as tentative values used only for design purposes. They are not guaranteed values.

## (2) Term Definitions

- Resolution  
Level of analog variation that can be distinguished by the A/D converter.  
When the number of bits is 10, the analog voltage can be resolved into  $2^{10} = 1024$ .
- Total error  
Difference between actual and theoretical values, which is a total value derived from an offset error, gain error, non-linearity error and noise.
- Linearity error  
Deviation between the value along a straight line connecting the zero transition point (“00 0000 0000” $\longleftrightarrow$  “00 0000 0001”) of a device and the full-scale transition point (“11 1111 1110” $\longleftrightarrow$  “11 1111 1111”) compared with the actual conversion values obtained.
- Differential linearity error  
Deviation of input voltage, which is required for changing output code by 1 LSB, from an ideal value.

# MB91245/S Series

## • 10-bit A/D Converter- Conversion Characteristics

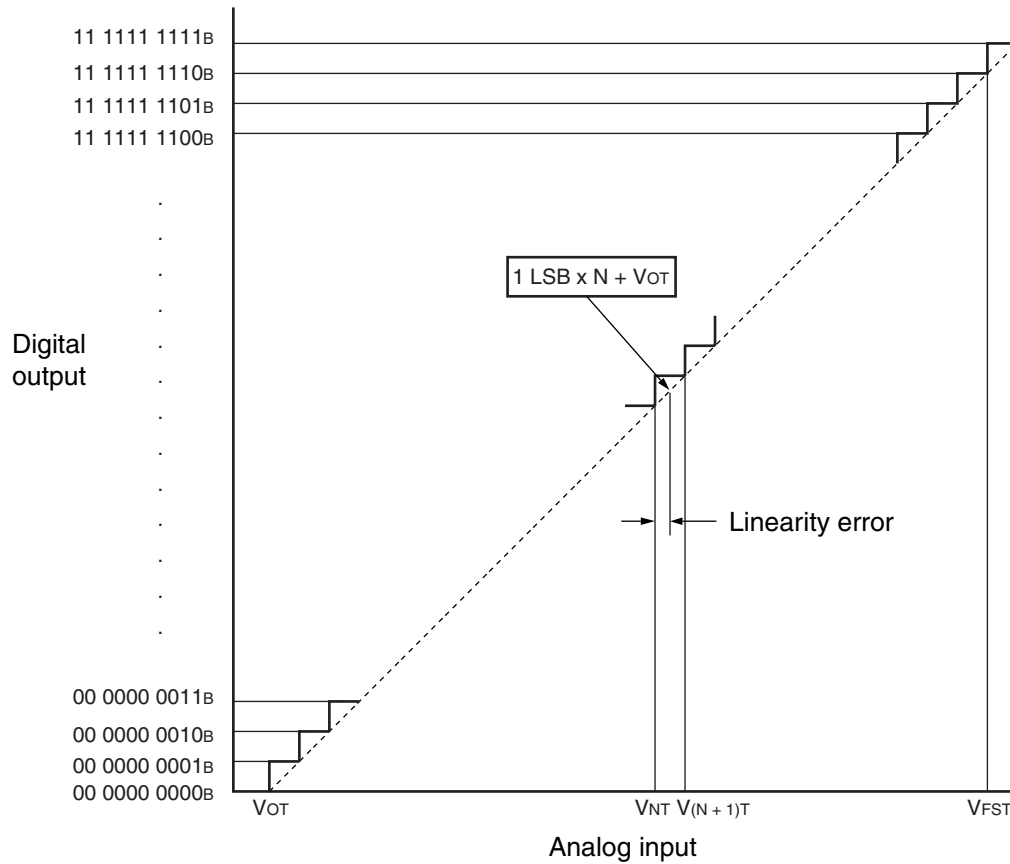

$$1 \text{ LSB} = \frac{V_{\text{FST}} - V_{\text{OT}}}{1022}$$

$$\text{Linearity error} = \frac{V_{\text{NT}} - (1 \text{ LSB} \times N + V_{\text{OT}})}{1 \text{ LSB}} \text{ [LSB]}$$

$$\text{Differential linearity error} = \frac{V_{(N+1)T} - V_{\text{NT}}}{1 \text{ LSB}} - 1 \text{ [LSB]}$$

N : A/D converter digital output value.

V<sub>OT</sub> : Voltage at which digital output transits from 000<sub>H</sub> to 001<sub>H</sub>.

V<sub>FST</sub> : Voltage at which digital output transits from 3FE<sub>H</sub> to 3FF<sub>H</sub>.

V<sub>NT</sub> : A voltage at which digital output transits from (N - 1) to N.

## EXAMPLE CHARACTERISTICS

(1) Power supply current (at main RUN)

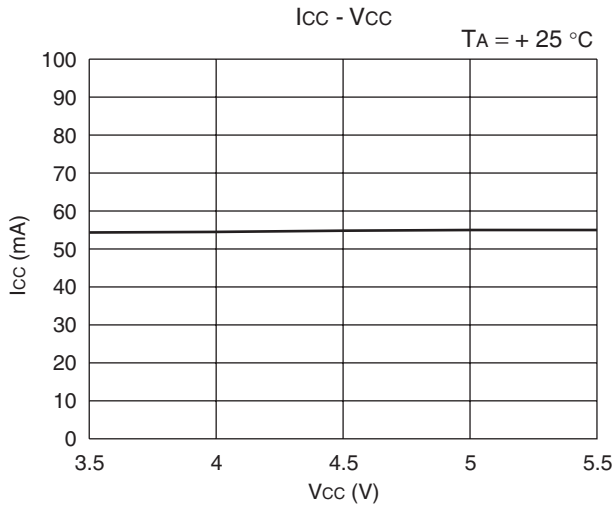

(2) Power supply current (at sub RUN)

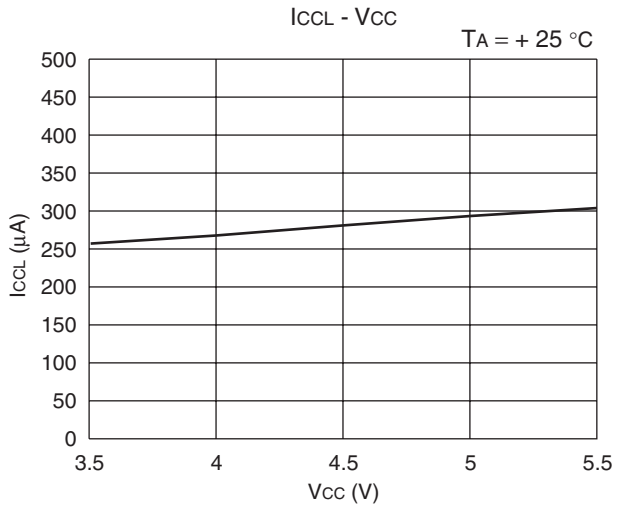

(3) Power supply current (at stop : when oscillation stops)

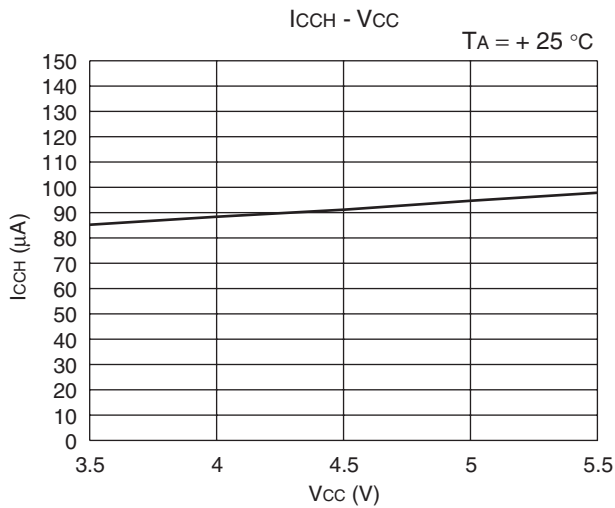

(4) Power supply current (at stop : when using RTC 4 MHz)

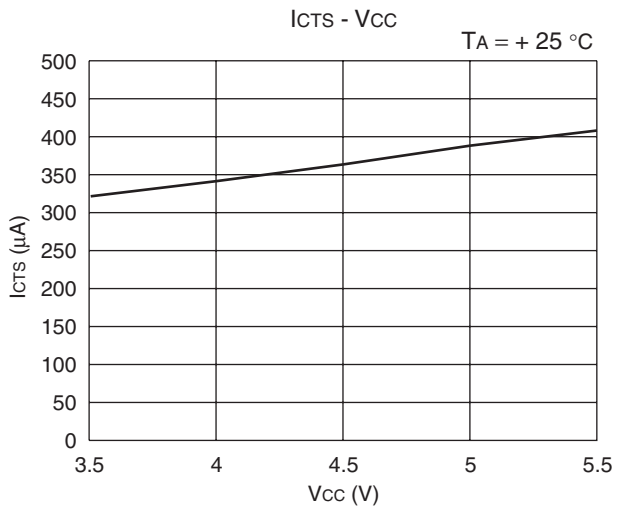

(Continued)

# MB91245/S Series

**(5) A/D power supply current**

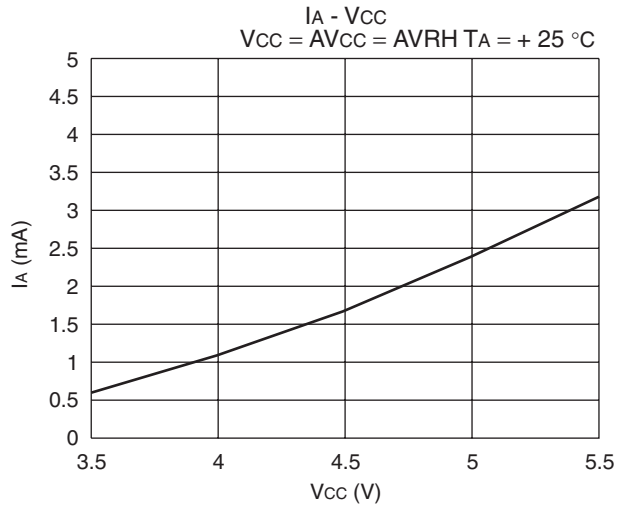

**(6) A/D reference voltage supply current**

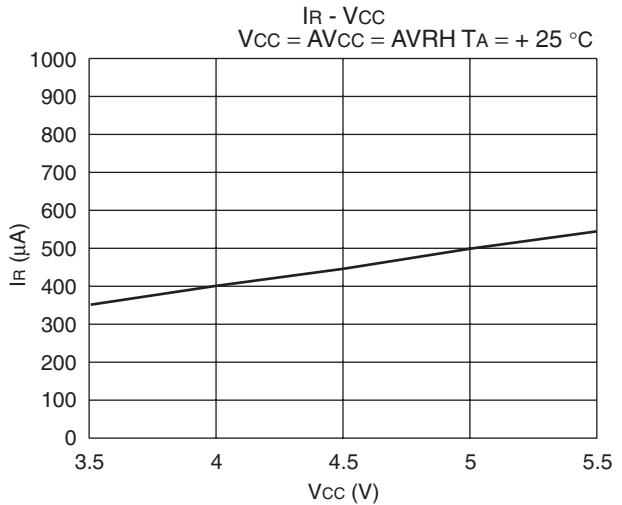

**(7) "H" level input voltage/"L" level input voltage (Automotive input)**

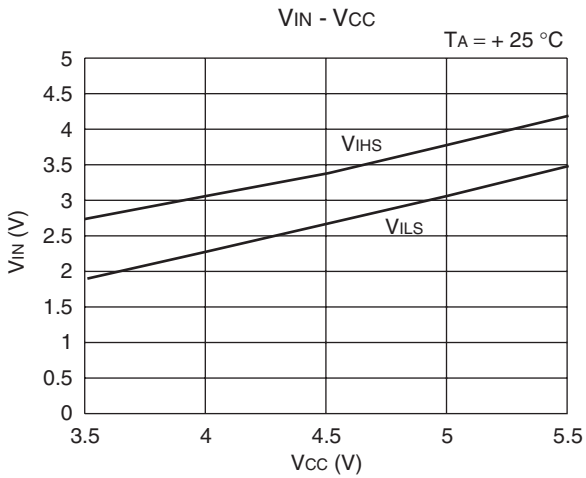

**(8) "H" level input voltage/"L" level input voltage (CMOS hysteresis input)**

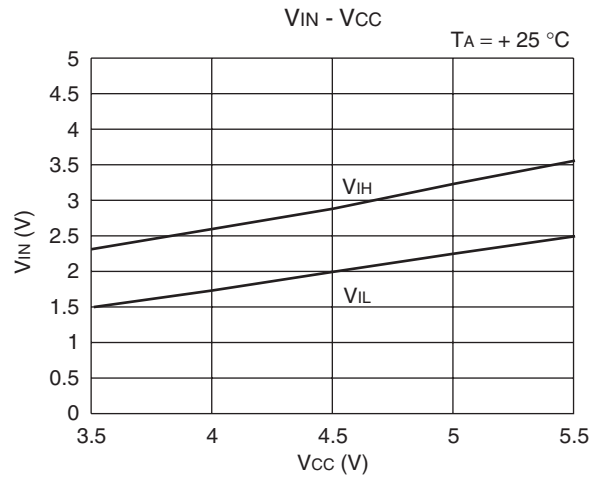

(Continued)

(Continued)

**(9) "H" level output voltage**

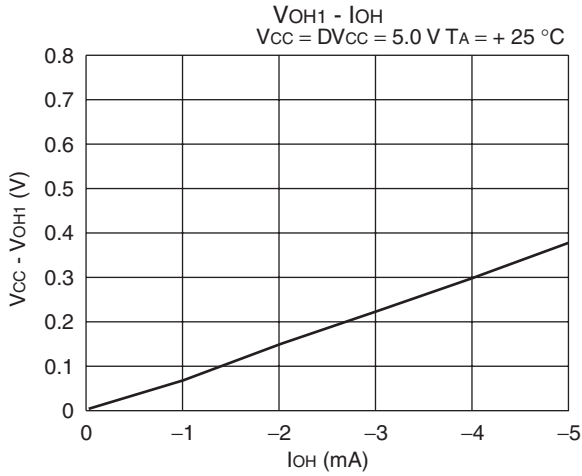

**(10) "H" level output voltage**

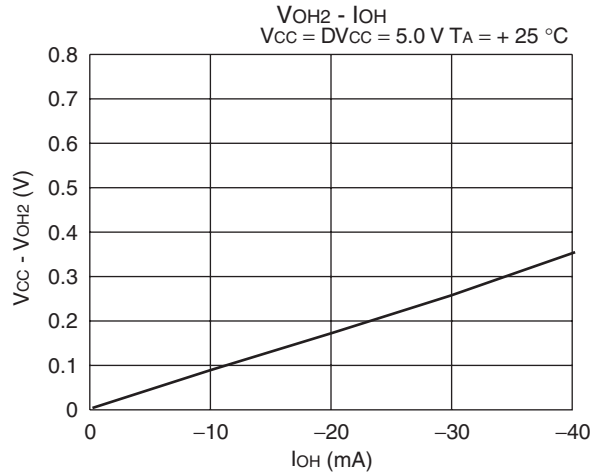

**(11) "L" level output voltage**

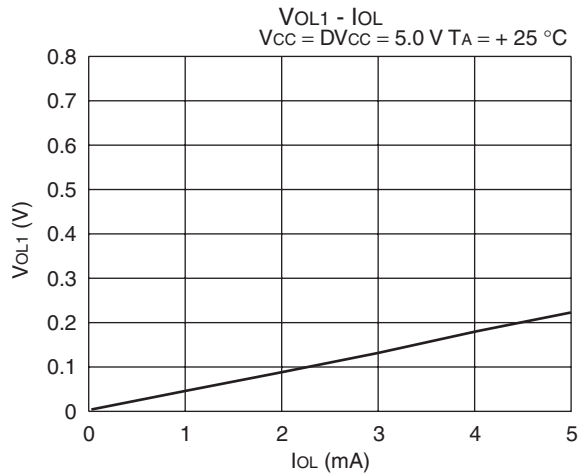

**(12) "L" level output voltage**

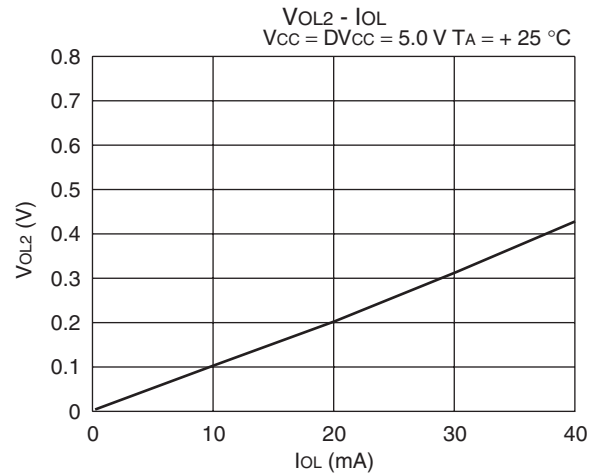

# MB91245/S Series

## ■ ORDERING INFORMATION

Part number	Package	Remarks
MB91V245ACR-ES	401-pin ceramic PGA (PGA-401C-A02)	Evaluation product
MB91F248PFV-GSE1	144-pin plastic LQFP (FPT-144P-M08)	Dual clock product
MB91F248SPFV-GSE1	144-pin plastic LQFP (FPT-144P-M08)	Single clock product
MB91247PFV-GSE1	144-pin plastic LQFP (FPT-144P-M08)	Dual clock product
MB91247SPFV-GSE1	144-pin plastic LQFP (FPT-144P-M08)	Single clock product
MB91248PFV-GSE1	144-pin plastic LQFP (FPT-144P-M08)	Dual clock product
MB91248SPFV-GSE1	144-pin plastic LQFP (FPT-144P-M08)	Single clock product

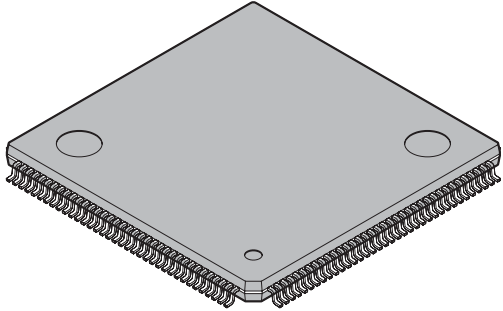

## ■ PACKAGE DIMENSION

<p>144-pin plastic LQFP</p>  <p>(FPT-144P-M08)</p>	Lead pitch	0.50 mm
	Package width × package length	20.0 × 20.0 mm
	Lead shape	Gullwing
	Sealing method	Plastic mold
	Mounting height	1.70 mm MAX
	Weight	1.20g
	Code (Reference)	P-LFQFP144-20×20-0.50

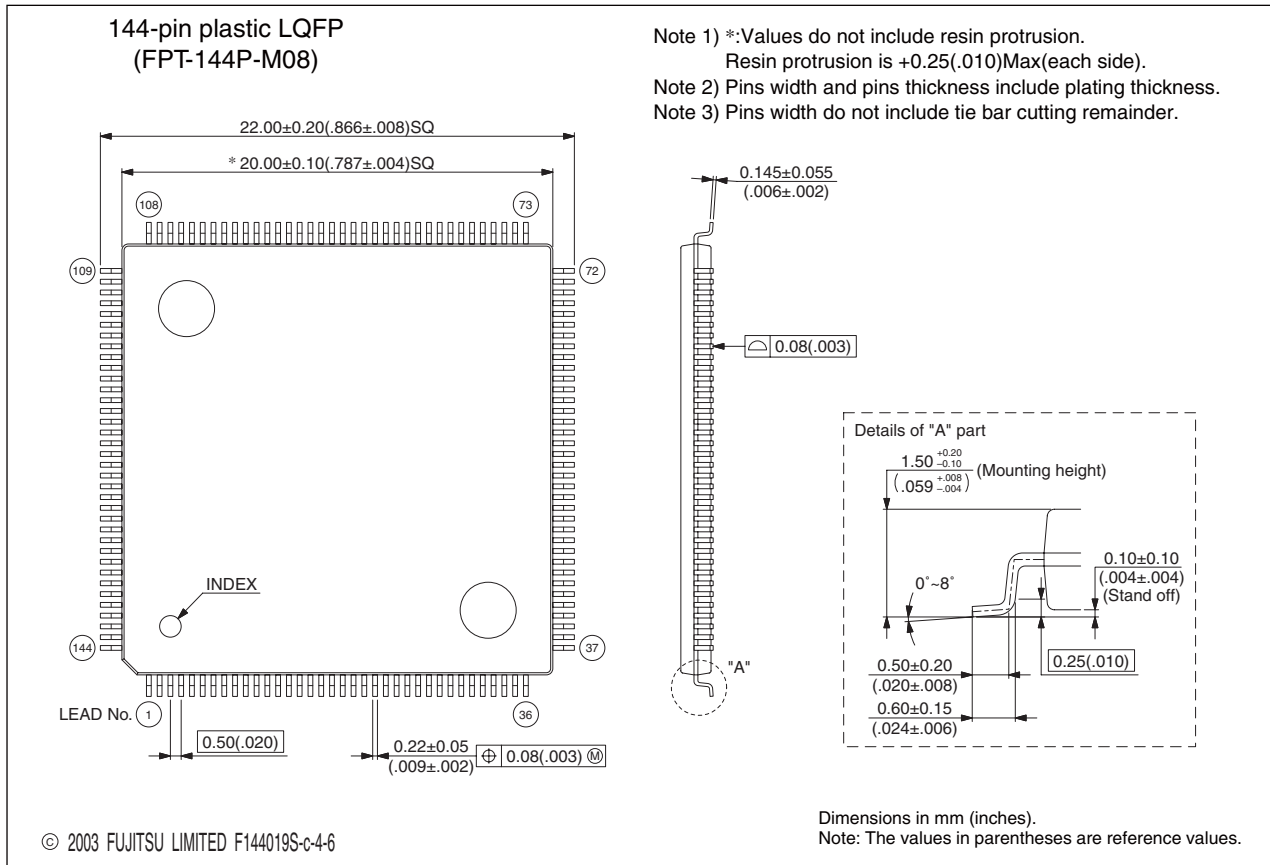

Please confirm the latest Package dimension by following URL.  
<http://edevic.fujitsu.com/fj/DATASHEET/ef-ovpklv.html>

## FUJITSU LIMITED

All Rights Reserved.

The contents of this document are subject to change without notice. Customers are advised to consult with FUJITSU sales representatives before ordering.

The information, such as descriptions of function and application circuit examples, in this document are presented solely for the purpose of reference to show examples of operations and uses of Fujitsu semiconductor device; Fujitsu does not warrant proper operation of the device with respect to use based on such information. When you develop equipment incorporating the device based on such information, you must assume any responsibility arising out of such use of the information. Fujitsu assumes no liability for any damages whatsoever arising out of the use of the information.

Any information in this document, including descriptions of function and schematic diagrams, shall not be construed as license of the use or exercise of any intellectual property right, such as patent right or copyright, or any other right of Fujitsu or any third party or does Fujitsu warrant non-infringement of any third-party's intellectual property right or other right by using such information. Fujitsu assumes no liability for any infringement of the intellectual property rights or other rights of third parties which would result from the use of information contained herein.

The products described in this document are designed, developed and manufactured as contemplated for general use, including without limitation, ordinary industrial use, general office use, personal use, and household use, but are not designed, developed and manufactured as contemplated (1) for use accompanying fatal risks or dangers that, unless extremely high safety is secured, could have a serious effect to the public, and could lead directly to death, personal injury, severe physical damage or other loss (i.e., nuclear reaction control in nuclear facility, aircraft flight control, air traffic control, mass transport control, medical life support system, missile launch control in weapon system), or (2) for use requiring extremely high reliability (i.e., submersible repeater and artificial satellite).

Please note that Fujitsu will not be liable against you and/or any third party for any claims or damages arising in connection with above-mentioned uses of the products.

Any semiconductor devices have an inherent chance of failure. You must protect against injury, damage or loss from such failures by incorporating safety design measures into your facility and equipment such as redundancy, fire protection, and prevention of over-current levels and other abnormal operating conditions.

If any products described in this document represent goods or technologies subject to certain restrictions on export under the Foreign Exchange and Foreign Trade Law of Japan, the prior authorization by Japanese government will be required for export of those products from Japan.

Edited Business Promotion Dept.