

## 16-bit Proprietary Microcontroller

CMOS

# F<sup>2</sup>MC-16FX MB966C0 Series

## MB96F6C6\*

### ■ DESCRIPTION

MB966C0 series is based on FUJITSU's advanced 16FX architecture (16-bit with instruction pipeline for RISC-like performance). The CPU uses the same instruction set as the established 16LX series - thus allowing for easy migration of 16LX Software to the new 16FX products.

16FX improvements compared to the previous generation include significantly improved performance - even at the same operation frequency, reduced power consumption and faster start-up time.

For high processing speed at optimized power consumption an internal PLL can be selected to supply the CPU with up to 32MHz operation frequency from an external 4MHz resonator. The result is a minimum instruction cycle time of 31.2ns going together with excellent EMI behavior. The emitted power is minimized by the on-chip voltage regulator that reduces the internal CPU voltage. A flexible clock tree allows selecting suitable operation frequencies for peripheral resources independent of the CPU speed.

\*: These devices are under development and specification is preliminary.

These products under development may change its specification without notice.

Note: F<sup>2</sup>MC is the abbreviation of FUJITSU Flexible Microcontroller.

For the information for microcontroller supports, see the following website.

<http://edevice.fujitsu.com/micom/en-support/>

## ■ FEATURES

### ● Technology

- 0.18 $\mu$ m CMOS

### ● CPU

- F<sup>2</sup>MC-16FX CPU
- Optimized instruction set for controller applications (bit, byte, word and long-word data types, 23 different addressing modes, barrel shift, variety of pointers)
- 8-byte instruction execution queue
- Signed multiply (16-bit  $\times$  16-bit) and divide (32-bit/16-bit) instructions available

### ● System clock

- On-chip PLL clock multiplier ( $\times 1$  to  $\times 8$ ,  $\times 1$  when PLL stop)
- 4 MHz to 8 MHz external crystal oscillator clock (maximum frequency when using ceramic resonator depends on Q-factor)
- Up to 16 MHz external clock for devices with fast clock input feature
- 32.768 kHz subsystem quartz clock
- 100kHz/2MHz internal RC clock for quick and safe startup, oscillator stop detection, watchdog
- Clock source selectable from mainclock oscillator, subclock oscillator and on-chip RC oscillator, independently for CPU and 2 clock domains of peripherals
- The subclock oscillator is enabled by the Boot ROM program controlled by a configuration marker after a Power or External reset
- Low Power Consumption - 13 operating modes (different Run, Sleep, Timer modes, Stop mode)

### ● On-chip voltage regulator

- Internal voltage regulator supports reduced internal MCU voltage, offering low EMI and low power consumption figures

### ● Low voltage reset

- Reset is generated when supply voltage is below minimum

### ● Code Security

- Protects Flash Memory content from unintended read-out

### ● DMA

- Automatic transfer function independent of CPU, can be assigned freely to resources

### ● Interrupts

- Fast Interrupt processing
- 8 programmable priority levels
- Non-Maskable Interrupt (NMI)

**● CAN**

- Supports CAN protocol version 2.0 part A and B
- ISO16845 certified
- Bit rates up to 1 Mbit/s
- 32 message objects
- Each message object has its own identifier mask
- Programmable FIFO mode (concatenation of message objects)
- Maskable interrupt
- Disabled Automatic Retransmission mode for Time Triggered CAN applications
- Programmable loop-back mode for self-test operation

**● USART**

- Full duplex USARTs (SCI/LIN)
- Wide range of baud rate settings using a dedicated reload timer
- Special synchronous options for adapting to different synchronous serial protocols
- LIN functionality working either as master or slave LIN device
- Extended support for LIN-Protocol with 16-byte FIFO for selected channels to reduce interrupt load

**● I<sup>2</sup>C**

- Up to 400 kbps
- Master and Slave functionality, 7-bit and 10-bit addressing

**● A/D converter**

- SAR-type
- 8/10-bit resolution
- Signals interrupt on conversion end, single conversion mode, continuous conversion mode, stop conversion mode, activation by software, external trigger, reload timers and PPGs
- Range Comparator Function
- Scan Disable Function
- ADC Pulse Detection Function

**● Source Clock Timers**

- Three independent clock timers (23-bit RC clock timer, 23-bit Main clock timer, 17-bit Sub clock timer)

**● Hardware Watchdog Timer**

- Hardware watchdog timer is active after reset
- Window function of Watchdog Timer is used to select the lower window limit of the watchdog interval

**● Reload Timers**

- 16-bit wide
- Prescaler with  $1/2^1$ ,  $1/2^2$ ,  $1/2^3$ ,  $1/2^4$ ,  $1/2^5$ ,  $1/2^6$  of peripheral clock frequency
- Event count function

**● Free Running Timers**

- Signals an interrupt on overflow, supports timer clear upon match with Output Compare 0
- Prescaler with 1,  $1/2^1$ ,  $1/2^2$ ,  $1/2^3$ ,  $1/2^4$ ,  $1/2^5$ ,  $1/2^6$ ,  $1/2^7$ ,  $1/2^8$  of peripheral clock frequency

**● Input Capture Units**

- 16-bit wide
- Signals an interrupt upon external event
- Rising edge, Falling edge or Both (rising&falling) edges sensitive

**● Output Compare Units**

- 16-bit wide
- Signals an interrupt when a match with 16-bit I/O Timer occurs
- A pair of compare registers can be used to generate an output signal

**● Programmable Pulse Generator**

- 16-bit down counter, cycle and duty setting registers
- Can be used as  $2 \times 8$ -bit PPG
- Interrupt at trigger, counter borrow and/or duty match
- PWM operation and one-shot operation
- Internal prescaler allows 1, 1/4, 1/16, 1/64 of peripheral clock as counter clock or of selected Reload timer underflow as clock input
- Can be triggered by software or reload timer
- Can trigger ADC conversion
- Timing point capture
- Start delay

**● Quadrature Position/Revolution Counter (QPRC)**

- Edge count mode, Phase count mode, Level count mode
- 16-bit position counter
- 16-bit revolution counter
- Two 16-bit compare registers with interrupt
- Detection edge of the three external event input pins AIN, BIN and ZIN is configurable

**● LCD Controller**

- LCD controller with up to  $4 \text{ COM} \times 44\text{SEG}$
- Internal or external voltage generation
- Duty cycle: Selectable from options: 1/2, 1/3 and 1/4
- Fixed 1/3 bias
- Programmable frame period
- Clock source selectable from four options (main clock, peripheral clock, subclock or RC oscillator clock)
- On-chip drivers for internal divider resistors or external divider resistors
- On-chip data memory for display
- LCD display can be operated in Timer Mode
- Blank display: selectable
- All SEG, COM and V pins can be switched between general and specialized purposes

**● Real Time Clock**

- Operational on main oscillation (4MHz), sub oscillation (32kHz) or RC oscillation (100kHz/2MHz)
- Capable to correct oscillation deviation of Sub clock or RC oscillator clock (clock calibration)
- Read/write accessible second/minute/hour registers
- Can signal interrupts every half second/second/minute/hour/day
- Internal clock divider and prescaler provide exact 1s clock

**● External Interrupts**

- Edge or Level sensitive
- Interrupt mask and pending bit per channel
- Each available CAN channel RX has an external interrupt for wake-up
- Selected USART channels SIN have an external interrupt for wake-up

**● Non Maskable Interrupt**

- Disabled after reset, can be enabled by Boot-ROM depending on ROM configuration block
- Once enabled, can not be disabled other than by reset
- High or Low level sensitive
- Pin shared with external interrupt 0

**● I/O Ports**

- Most of the external pins can be used as general purpose I/O
- All push-pull outputs (except when used as I<sup>2</sup>C SDA/SCL line)
- Bit-wise programmable as input/output or peripheral signal
- Bit-wise programmable input enable
- One input level per GP-IO-pin (either Automotive or CMOS-Schmitt trigger)
- Bit-wise programmable pull-up resistor

**● Built-in OCD (On Chip Debugger)**

- One-wire debug tool interface
- Break function:
  - Hardware break: 6 points (shared with code event)
  - Software break: 4096 points
- Event function
  - Code event: 6 points (shared with hardware break)
  - Data event: 6 points
  - Event sequencer: 2 levels
- Execution time measurement function
- Trace function: 42 branches
- Security function

**● Flash Memory**

- Dual operation flash allowing reading of one Flash bank while programming or erasing the other bank
- Command sequencer for automatic execution of programming algorithm and for supporting DMA for programming of the Flash Memory
- Supports automatic programming, Embedded Algorithm
- Write/Erase/Erase-Suspend/Resume commands
- A flag indicating completion of the algorithm
- Erase can be performed on each sector individually
- Sector protection
- Flash Security feature to protect the content of the Flash
- Low voltage detection during Flash erase

## ■ PRODUCT LINEUP

Features		MB96F6Cx	Remark
Product type		Flash product	
Subclock		Subclock can be set by software	
Dual Operation Flash memory	RAM		
256.5KB + 32KB	16KB	MB96F6C6	
Package		LQFP-120 FPT-120P-M21	
DMA		4ch	
USART		5ch	LIN-USART 0/1/2/4/5
with automatic LIN-Header transmission/reception		2ch	LIN-USART 0/1
with 16 byte RX- and TX-FIFO			
I <sup>2</sup> C		1ch	I <sup>2</sup> C 0
10-bit A/D Converter		32ch	AN 0 to 31
with Data Buffer		No	
with Range Comparator		Yes	
with Scan Disable		Yes	
with ADC Pulse Detection		Yes	
16-bit Reload Timer (RLT)		5ch	RLT 0/1/2/3/6 Only RLT6 can be used as PPG clock source.
16-bit Free-Running Timer (FRT)		2ch	FRT 0/1
16-bit Input Capture Unit (ICU)		8ch (5 channels for LIN-USART)	ICU 0 to 7 ICU 0/1/4/5/6 for LIN-USART
16-bit Output Compare Unit (OCU)		4ch	OCU 0 to 3
8/16-bit Programmable Pulse Generator (PPG)		12ch (16-bit) / 24ch (8-bit)	PPG 0 to 7/12 to 15
with Timing point capture		Yes	
with Start delay		Yes	
with Ramp		No	
Quadrature position/revolution counter (QPRC)		2ch	QPRC 0/1
CAN Interface		1ch	CAN 0 32 Message Buffers
External Interrupts (INTerrupt)		16ch	INT 0 to 15
Non-Maskable Interrupt (NMI)		1ch	
LCD Controller		4 COM × 44 SEG	COM 0 to 3 SEG 0 to 4/7 to 45
Real Time Clock (RTC)		1ch	
I/O Ports		97 (Dual clock mode) 99 (Single clock mode)	
Clock Calibration Unit (CAL)		1ch	
Clock Output Function		2ch	
Low Voltage Reset		Yes	Low voltage reset can be disabled by software
Hardware Watchdog Timer		Yes	
On-chip RC-oscillator		Yes	
On-chip Debugger		Yes	

Notes: • All signals of the peripheral function in each product cannot be allocated by limiting the pins of package. It is necessary to use the port relocate function of the General I/O port according to your function use.

- These devices are under development and specification is preliminary.  
These products under development may change its specification without notice.

## ■ BLOCK DIAGRAM

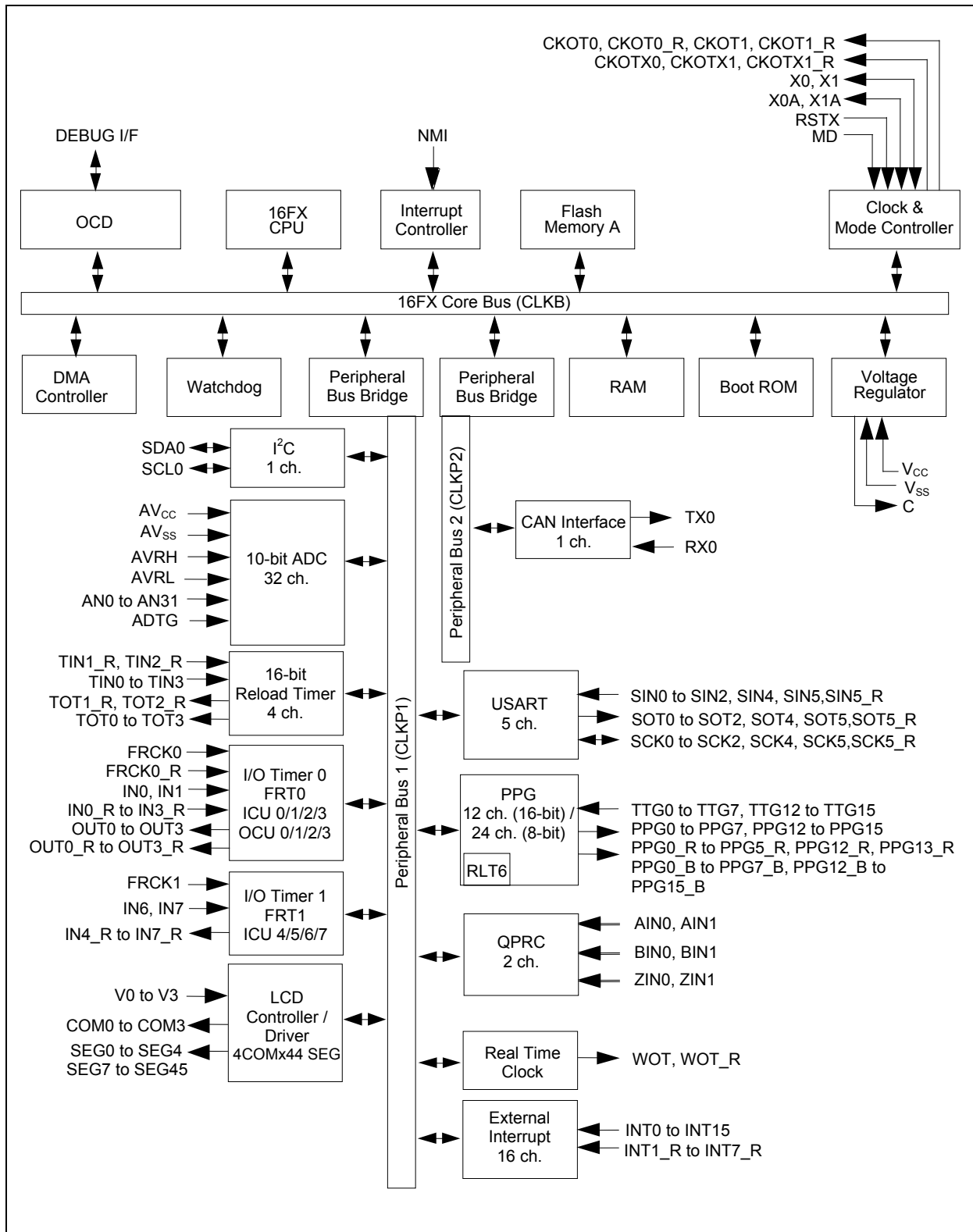



■ PIN ASSIGNMENTS

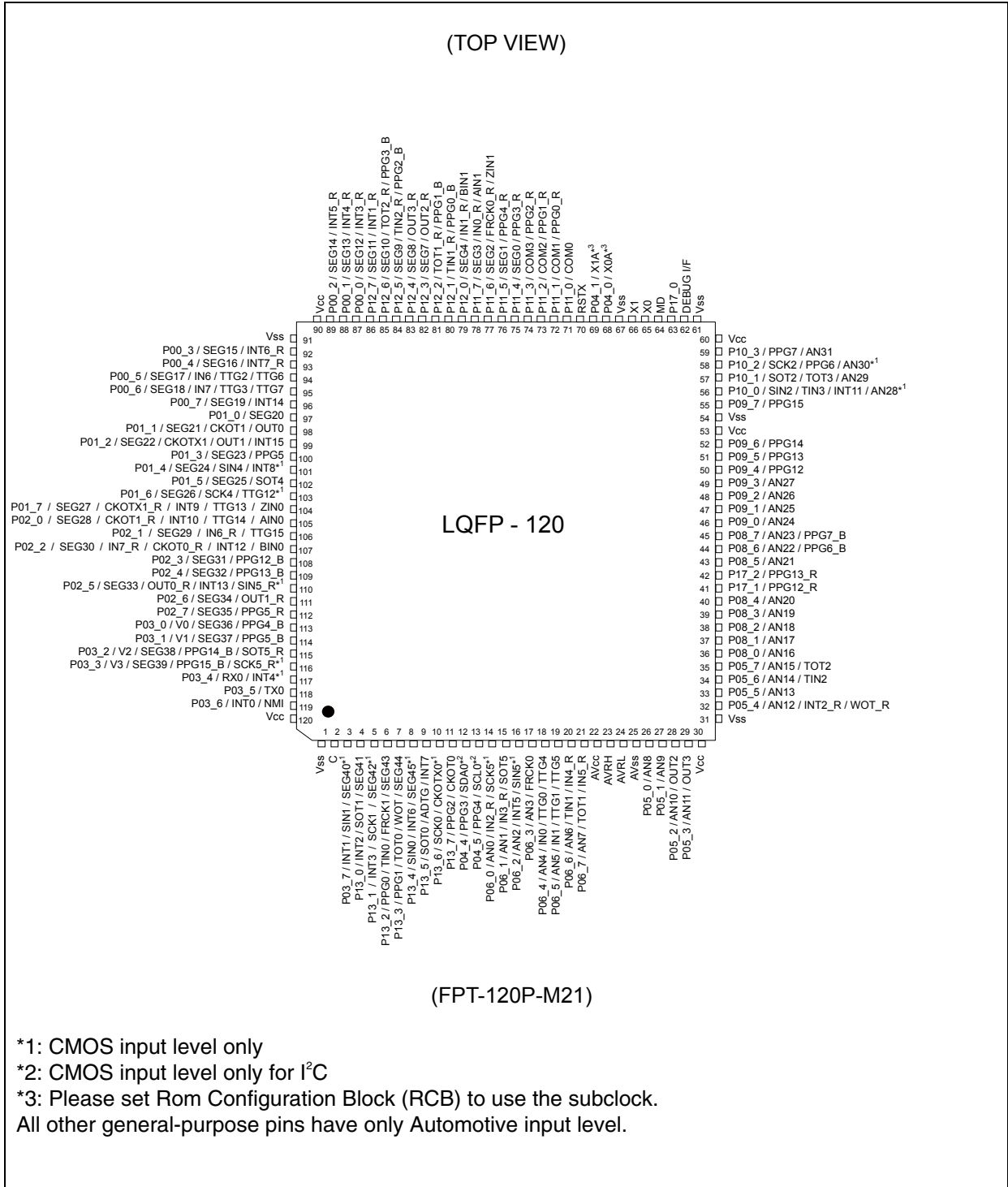

## ■ PIN FUNCTION DESCRIPTION

Pin name	Feature	Description
ADTG	ADC	A/D converter trigger input
AINn	QPRC	Quadrature Position/Revolution Counter Unit n input
ANn	ADC	A/D converter channel n input
AVcc	Supply	Analog circuits power supply
AVRH	ADC	A/D converter high reference voltage input
AVRL	ADC	A/D converter low reference voltage input
AVss	Supply	Analog circuits power supply
BINn	QPRC	Quadrature Position/Revolution Counter Unit n input
C	Voltage regulator	Internally regulated power supply stabilization capacitor pin
CKOTn	Clock output function	Clock Output function n output
CKOTn_R	Clock output function	Relocated Clock Output function n output
CKOTXn	Clock output function	Clock Output function n inverted output
CKOTXn_R	Clock output function	Relocated Clock Output function n inverted output
COMn	LCD	LCD Common driver
FRCKn	Free Running Timer	Free Running Timer n input
FRCKn_R	Free Running Timer	Relocated Free Running Timer n input
INn	ICU	Input Capture Unit n input
INn_R	ICU	Relocated Input Capture Unit n input
INTn	External Interrupt	External Interrupt n input
INTn_R	External Interrupt	Relocated External Interrupt n input
MD	Core	Input pin for specifying the operating mode
NMI	External Interrupt	Non-Maskable Interrupt input
OUTn	OCU	Output Compare Unit n waveform output
OUTn_R	OCU	Relocated Output Compare Unit n waveform output
Pnn_m	GPIO	General purpose I/O
PPGn	PPG	Programmable Pulse Generator n output (16bit/8bit)
PPGn_R	PPG	Relocated Programmable Pulse Generator n output (16bit/8bit)
PPGn_B	PPG	Programmable Pulse Generator n output (8bit)
RSTX	Core	Reset input
RXn	CAN	CAN interface n RX input
SCKn	USART	USART n serial clock input/output
SCKn_R	USART	Relocated USART n serial clock input/output
SCLn	I <sup>2</sup> C	I <sup>2</sup> C interface n clock I/O input/output
SDAn	I <sup>2</sup> C	I <sup>2</sup> C interface n serial data I/O input/output
SEGn	LCD	LCD Segment driver
SINn	USART	USART n serial data input
SINn_R	USART	Relocated USART n serial data input
SOTn	USART	USART n serial data output
SOTn_R	USART	Relocated USART n serial data output
TINn	Reload Timer	Reload Timer n event input
TINn_R	Reload Timer	Relocated Reload Timer n event input
TOTn	Reload Timer	Reload Timer n output
TOT_R	Reload Timer	Relocated Reload Timer n output
TTGn	PPG	Programmable Pulse Generator n trigger input

Pin name	Feature	Description
TXn	CAN	CAN interface n TX output
Vn	LCD	LCD voltage reference
Vcc	Supply	Power supply
Vss	Supply	Power supply
WOT	RTC	Real Time clock output
WOT_R	RTC	Relocated Real Time clock output
X0	Clock	Oscillator input
X0A	Clock	Subclock Oscillator input
X1	Clock	Oscillator output
X1A	Clock	Subclock Oscillator output
ZINn	QPRC	Quadrature Position/Revolution Counter Unit n input
DEBUG I/F	OCD	On Chip Debugger input/output

## ■ PIN CIRCUIT TYPE

Pin no.	I/O circuit type*	Pin name
1	Supply	V <sub>ss</sub>
2	F	C
3	P	P03_7 / INT1 / SIN1 / SEG40
4	J	P13_0 / INT2 / SOT1 / SEG41
5	P	P13_1 / INT3 / SCK1 / SEG42
6	J	P13_2 / PPG0 / TIN0 / FRCK1 / SEG43
7	J	P13_3 / PPG1 / TOT0 / WOT / SEG44
8	P	P13_4 / SIN0 / INT6 / SEG45
9	H	P13_5 / SOT0 / ADTG / INT7
10	M	P13_6 / SCK0 / CKOTX0
11	H	P13_7 / PPG2 / CKOT0
12	N	P04_4 / PPG3 / SDA0
13	N	P04_5 / PPG4 / SCL0
14	I	P06_0 / AN0 / IN2_R / SCK5
15	K	P06_1 / AN1 / IN3_R / SOT5
16	I	P06_2 / AN2 / INT5 / SIN5
17	K	P06_3 / AN3 / FRCK0
18	K	P06_4 / AN4 / IN0 / TTG0 / TTG4
19	K	P06_5 / AN5 / IN1 / TTG1 / TTG5
20	K	P06_6 / AN6 / TIN1 / IN4_R
21	K	P06_7 / AN7 / TOT1 / IN5_R
22	Supply	AV <sub>cc</sub>
23	G	AVRH
24	G	AVRL
25	Supply	AV <sub>ss</sub>
26	K	P05_0 / AN8
27	K	P05_1 / AN9
28	K	P05_2 / AN10 / OUT2
29	K	P05_3 / AN11 / OUT3
30	Supply	V <sub>cc</sub>
31	Supply	V <sub>ss</sub>
32	K	P05_4 / AN12 / INT2_R / WOT_R
33	K	P05_5 / AN13
34	K	P05_6 / AN14 / TIN2
35	K	P05_7 / AN15 / TOT2

Pin no.	I/O circuit type*	Pin name
36	K	P08_0 / AN16
37	K	P08_1 / AN17
38	K	P08_2 / AN18
39	K	P08_3 / AN19
40	K	P08_4 / AN20
41	H	P17_1 / PPG12_R
42	H	P17_2 / PPG13_R
43	K	P08_5 / AN21
44	K	P08_6 / AN22 / PPG6_B
45	K	P08_7 / AN23 / PPG7_B
46	K	P09_0 / AN24
47	K	P09_1 / AN25
48	K	P09_2 / AN26
49	K	P09_3 / AN27
50	H	P09_4 / PPG12
51	H	P09_5 / PPG13
52	H	P09_6 / PPG14
53	Supply	Vcc
54	Supply	Vss
55	H	P09_7 / PPG15
56	I	P10_0 / SIN2 / TIN3 / INT11 / AN28
57	K	P10_1 / SOT2 / TOT3 / AN29
58	I	P10_2 / SCK2 / PPG6 / AN30
59	K	P10_3 / PPG7 / AN31
60	Supply	Vcc
61	Supply	Vss
62	O	DEBUG I/F
63	H	P17_0
64	C	MD
65	A	X0
66	A	X1
67	Supply	Vss
68	B	P04_0 / X0A
69	B	P04_1 / X1A
70	C	RSTX

Pin no.	I/O circuit type*	Pin name
71	J	P11_0 / COM0
72	J	P11_1 / COM1 / PPG0_R
73	J	P11_2 / COM2 / PPG1_R
74	J	P11_3 / COM3 / PPG2_R
75	J	P11_4 / SEG0 / PPG3_R
76	J	P11_5 / SEG1 / PPG4_R
77	J	P11_6 / SEG2 / FRCK0_R / ZIN1
78	J	P11_7 / SEG3 / IN0_R / AIN1
79	J	P12_0 / SEG4 / IN1_R / BIN1
80	H	P12_1 / TIN1_R / PPG0_B
81	H	P12_2 / TOT1_R / PPG1_B
82	J	P12_3 / SEG7 / OUT2_R
83	J	P12_4 / SEG8 / OUT3_R
84	J	P12_5 / SEG9 / TIN2_R / PPG2_B
85	J	P12_6 / SEG10 / TOT2_R / PPG3_B
86	J	P12_7 / SEG11 / INT1_R
87	J	P00_0 / SEG12 / INT3_R
88	J	P00_1 / SEG13 / INT4_R
89	J	P00_2 / SEG14 / INT5_R
90	Supply	Vcc
91	Supply	Vss
92	J	P00_3 / SEG15 / INT6_R
93	J	P00_4 / SEG16 / INT7_R
94	J	P00_5 / SEG17 / IN6 / TTG2 / TTG6
95	J	P00_6 / SEG18 / IN7 / TTG3 / TTG7
96	J	P00_7 / SEG19 / INT14
97	J	P01_0 / SEG20
98	J	P01_1 / SEG21 / CKOT1 / OUT0
99	J	P01_2 / SEG22 / CKOTX1 / OUT1 / INT15
100	J	P01_3 / SEG23 / PPG5
101	P	P01_4 / SEG24 / SIN4 / INT8
102	J	P01_5 / SEG25 / SOT4
103	P	P01_6 / SEG26 / SCK4 / TTG12
104	J	P01_7 / SEG27 / CKOTX1_R / INT9 / TTG13 / ZIN0
105	J	P02_0 / SEG28 / CKOT1_R / INT10 / TTG14 / AIN0

Pin no.	I/O circuit type*	Pin name
106	J	P02_1 / SEG29 / IN6_R / TTG15
107	J	P02_2 / SEG30 / IN7_R / CKOT0_R / INT12 / BIN0
108	J	P02_3 / SEG31 / PPG12_B
109	J	P02_4 / SEG32 / PPG13_B
110	P	P02_5 / SEG33 / OUT0_R / INT13 / SIN5_R
111	J	P02_6 / SEG34 / OUT1_R
112	J	P02_7 / SEG35 / PPG5_R
113	L	P03_0 / V0 / SEG36 / PPG4_B
114	L	P03_1 / V1 / SEG37 / PPG5_B
115	L	P03_2 / V2 / SEG38 / PPG14_B / SOT5_R
116	Q	P03_3 / V3 / SEG39 / PPG15_B / SCK5_R
117	M	P03_4 / RX0 / INT4
118	H	P03_5 / TX0
119	H	P03_6 / INT0 / NMI
120	Supply	Vcc

\*: Please refer to “■ I/O CIRCUIT TYPE” for details on the I/O circuit types.

■ I/O CIRCUIT TYPE

Type	Circuit	Remarks
A		<p>High-speed oscillation circuit:</p> <ul style="list-style-type: none"> <li>· Programmable between oscillation mode (external crystal or resonator connected to X0/X1 pins) and Fast external Clock Input (FCI) mode (external clock connected to X0 pin)</li> <li>· Feedback resistor = approx. 1.0 MΩ. Feedback resistor is grounded in the center when the oscillator is disabled or in FCI mode</li> <li>· The amplitude: 1.8V±0.15V to operate by the internal supply voltage</li> </ul>



Type	Circuit	Remarks
B	<p>The diagram for Type B shows a pull-up control circuit with a P-channel MOSFET (P-ch) and an N-channel MOSFET (N-ch). The P-ch MOSFET is controlled by a 'Pull-up control' signal and has its source connected to ground. The N-ch MOSFET is controlled by an 'N-ch' signal and has its source connected to ground. A 'Standby control for input shutdown' signal is connected to a resistor 'R' and a switch. The switch is controlled by a 'Hysteresis input' signal. The circuit also includes an oscillator section with pins X1A and X0A, a feedback resistor 'R', and a switch controlled by 'FCI or Osc disable'. The oscillator output is labeled 'X out' and is connected to a flip-flop with inputs '0' and '1' and a clock input 'FCI'.</p>	<p>Low-speed oscillation circuit shared with GPIO functionality:</p> <ul style="list-style-type: none"> <li>• Feedback resistor = approx. 5.0 MΩ. Feedback resistor is grounded in the center when the oscillator is disabled</li> <li>• GPIO functionality selectable (CMOS hysteresis input with input shutdown function, <math>I_{OL} = 4\text{mA}</math>, <math>I_{OH} = -4\text{mA}</math>, Programmable pull-up resistor)</li> </ul>
C	<p>The diagram for Type C shows a resistor 'R' connected to a CMOS hysteresis input pin. The input pin is represented by a dashed box containing a CMOS hysteresis input symbol.</p>	<ul style="list-style-type: none"> <li>• CMOS hysteresis input pin</li> </ul>

Type	Circuit	Remarks
F		<ul style="list-style-type: none"> <li>Power supply input protection circuit</li> </ul>
G		<ul style="list-style-type: none"> <li>A/D converter ref+ (AVRH) power supply input pin with protection circuit</li> <li>Without protection circuit against <math>V_{CC}</math> for pins AVRH</li> </ul>
H		<ul style="list-style-type: none"> <li>CMOS level output (<math>I_{OL} = 4\text{mA}</math>, <math>I_{OH} = -4\text{mA}</math>)</li> <li>Automotive input with input shutdown function</li> <li>Programmable pull-up resistor</li> </ul>
I		<ul style="list-style-type: none"> <li>CMOS level output (<math>I_{OL} = 4\text{mA}</math>, <math>I_{OH} = -4\text{mA}</math>)</li> <li>CMOS hysteresis input with input shutdown function</li> <li>Programmable pull-up resistor</li> <li>Analog input</li> </ul>

Type	Circuit	Remarks
J		<ul style="list-style-type: none"> <li>• CMOS level output (<math>I_{OL} = 4\text{mA}</math>, <math>I_{OH} = -4\text{mA}</math>)</li> <li>• Automotive input with input shutdown function</li> <li>• Programmable pull-up resistor</li> <li>• SEG or COM output</li> </ul>
K		<ul style="list-style-type: none"> <li>• CMOS level output (<math>I_{OL} = 4\text{mA}</math>, <math>I_{OH} = -4\text{mA}</math>)</li> <li>• Automotive input with input shutdown function</li> <li>• Programmable pull-up resistor</li> <li>• Analog input</li> </ul>
L		<ul style="list-style-type: none"> <li>• CMOS level output (<math>I_{OL} = 4\text{mA}</math>, <math>I_{OH} = -4\text{mA}</math>)</li> <li>• Automotive input with input shutdown function</li> <li>• Programmable pull-up resistor</li> <li>• Vx input or SEG output</li> </ul>

Type	Circuit	Remarks
M		<ul style="list-style-type: none"> <li>• CMOS level output (<math>I_{OL} = 4\text{mA}</math>, <math>I_{OH} = -4\text{mA}</math>)</li> <li>• CMOS hysteresis input with input shutdown function</li> <li>• Programmable pull-up resistor</li> </ul>
N		<ul style="list-style-type: none"> <li>• CMOS level output (<math>I_{OL} = 3\text{mA}</math>, <math>I_{OH} = -3\text{mA}</math>)</li> <li>• CMOS hysteresis input with input shutdown function</li> <li>• Programmable pull-up resistor</li> </ul> <p>*: N-channel transistor has slew rate control according to I<sup>2</sup>C spec, irrespective of usage.</p>
O		<ul style="list-style-type: none"> <li>• <math>I_{OL}: 25\text{mA} @ 2.7\text{V}</math></li> <li>• TTL input</li> </ul>

Type	Circuit	Remarks
P		<ul style="list-style-type: none"> <li>• CMOS level output (<math>I_{OL} = 4\text{mA}</math>, <math>I_{OH} = -4\text{mA}</math>)</li> <li>• CMOS hysteresis inputs with input shutdown function</li> <li>• Programmable pull-up resistor</li> <li>• SEG or COM output</li> </ul>
Q		<ul style="list-style-type: none"> <li>• CMOS level output (<math>I_{OL} = 4\text{mA}</math>, <math>I_{OH} = -4\text{mA}</math>)</li> <li>• CMOS hysteresis inputs with input shutdown function</li> <li>• Programmable pull-up resistor</li> <li>• SEG output or Vx input</li> </ul>

## ■ MEMORY MAP

MB96F6C6	
FF:FFFF <sub>H</sub>	USER ROM* 1
DE:0000 <sub>H</sub> DD:FFFF <sub>H</sub>	Reserved
10:0000 <sub>H</sub>	Boot-ROM
0F:E000 <sub>H</sub>	Peripheral
0E:9000 <sub>H</sub>	Reserved
01:0000 <sub>H</sub>	ROM/RAM MIRROR
00:8000 <sub>H</sub>	Internal RAM bank0
RAMSTART0* 2	Reserved
00:0C00 <sub>H</sub>	Peripheral
00:0380 <sub>H</sub>	GPR*3
00:0180 <sub>H</sub>	DMA
00:0100 <sub>H</sub>	Reserved
00:00F0 <sub>H</sub>	Reserved
00:0000 <sub>H</sub>	Peripheral

\*1: For details about USER ROM area, see the “■USER ROM MEMORY MAP FOR FLASH DEVICES” on the following pages.

\*2: For RAMSTART/END addresses, please refer to the table on the next page.

\*3: Unused GPR banks can be used as RAM area.

The DMA area is only available if the device contains the corresponding resource.  
The available RAM and ROM area depends on the device.

**■ RAMSTART ADDRESSES**

Devices	Bank 0 RAM size	RAMSTART0
MB96F6C6	16KByte	00:4200 <sub>H</sub>

## ■ USER ROM MEMORY MAP FOR FLASH DEVICES

		MB966C6		
Alternative mode CPU address	Flash memory mode address	Flash size 256.5KB + 32KB		
FF:FFFFH FF:0000H	3F:FFFFH 3F:0000H	SA39 - 64KB		Bank A of Flash A
FE:FFFFH FE:0000H	3E:FFFFH 3E:0000H	SA38 - 64KB		
FD:FFFFH FD:0000H	3D:FFFFH 3D:0000H	SA37 - 64KB		
FC:FFFFH FC:0000H	3C:FFFFH 3C:0000H	SA36 - 64KB		
FB:FFFFH		Reserved		
DF:A000H				
DF:9FFFH DF:8000H	1F:9FFFH 1F:8000H	SA4 - 8KB		Bank B of Flash A
DF:7FFFH DF:6000H	1F:7FFFH 1F:6000H	SA3 - 8KB		
DF:5FFFH DF:4000H	1F:5FFFH 1F:4000H	SA2 - 8KB		
DF:3FFFH DF:2000H	1F:3FFFH 1F:2000H	SA1 - 8KB		
DF:1FFFH DF:0000H	1F:1FFFH 1F:0000H	SAS - 512B*		Bank A of Flash A
DE:FFFFH DE:0000H		Reserved		

\*: Physical address area of SAS-512B is from DF:0000<sub>H</sub> to DF:01FF<sub>H</sub>.  
 Others (from DF:0200<sub>H</sub> to DF:1FFF<sub>H</sub>) are all ROM Mirror area for SAS-512B.  
 Sector SAS contains the ROM configuration block RCBA at CPU address DF:0000<sub>H</sub> -DF:01FF<sub>H</sub>.  
 SAS can not be used for E<sup>2</sup>PROM emulation.



## ■ SERIAL PROGRAMMING COMMUNICATION INTERFACE

USART pins for Flash serial programming (MD = 0, DEBUG I/F = 0, Serial Communication mode)

MB96F6C6		
Pin Number	USART Number	Normal Function
8	USART0	SIN0
9		SOT0
10		SCK0
3	USART1	SIN1
4		SOT1
5		SCK1
56	USART2	SIN2
57		SOT2
58		SCK2
101	USART4	SIN4
102		SOT4
103		SCK4

## ■ INTERRUPT VECTOR TABLE

Vector number	Offset in vector table	Vector name	Cleared by DMA	Index in ICR to program	Description
0	3FC	CALLV0	No	-	Reserved
1	3F8	CALLV1	No	-	Reserved
2	3F4	CALLV2	No	-	Reserved
3	3F0	CALLV3	No	-	Reserved
4	3EC	CALLV4	No	-	Reserved
5	3E8	CALLV5	No	-	Reserved
6	3E4	CALLV6	No	-	Reserved
7	3E0	CALLV7	No	-	Reserved
8	3DC	RESET	No	-	Reserved
9	3D8	INT9	No	-	Reserved
10	3D4	EXCEPTION	No	-	Reserved
11	3D0	NMI	No	-	Non-Maskable Interrupt
12	3CC	DLY	No	12	Delayed Interrupt
13	3C8	RC_TIMER	No	13	RC clock timer
14	3C4	MC_TIMER	No	14	Main Clock Timer
15	3C0	SC_TIMER	No	15	Sub Clock Timer
16	3BC	LVDI	No	16	Low Voltage Detector
17	3B8	EXTINT0	Yes	17	External Interrupt 0
18	3B4	EXTINT1	Yes	18	External Interrupt 1
19	3B0	EXTINT2	Yes	19	External Interrupt 2
20	3AC	EXTINT3	Yes	20	External Interrupt 3
21	3A8	EXTINT4	Yes	21	External Interrupt 4
22	3A4	EXTINT5	Yes	22	External Interrupt 5
23	3A0	EXTINT6	Yes	23	External Interrupt 6
24	39C	EXTINT7	Yes	24	External Interrupt 7
25	398	EXTINT8	Yes	25	External Interrupt 8
26	394	EXTINT9	Yes	26	External Interrupt 9
27	390	EXTINT10	Yes	27	External Interrupt 10
28	38C	EXTINT11	Yes	28	External Interrupt 11
29	388	EXTINT12	Yes	29	External Interrupt 12
30	384	EXTINT13	Yes	30	External Interrupt 13
31	380	EXTINT14	Yes	31	External Interrupt 14
32	37C	EXTINT15	Yes	32	External Interrupt 15
33	378	CAN0	No	33	CAN Controller 0
34	374	-	-	34	Reserved
35	370	-	-	35	Reserved
36	36C	-	-	36	Reserved
37	368	-	-	37	Reserved
38	364	PPG0	Yes	38	Programmable Pulse Generator 0
39	360	PPG1	Yes	39	Programmable Pulse Generator 1
40	35C	PPG2	Yes	40	Programmable Pulse Generator 2

Vector number	Offset in vector table	Vector name	Cleared by DMA	Index in ICR to program	Description
41	358	PPG3	Yes	41	Programmable Pulse Generator 3
42	354	PPG4	Yes	42	Programmable Pulse Generator 4
43	350	PPG5	Yes	43	Programmable Pulse Generator 5
44	34C	PPG6	Yes	44	Programmable Pulse Generator 6
45	348	PPG7	Yes	45	Programmable Pulse Generator 7
46	344	-	-	46	Reserved
47	340	-	-	47	Reserved
48	33C	-	-	48	Reserved
49	338	-	-	49	Reserved
50	334	PPG12	Yes	50	Programmable Pulse Generator 12
51	330	PPG13	Yes	51	Programmable Pulse Generator 13
52	32C	PPG14	Yes	52	Programmable Pulse Generator 14
53	328	PPG15	Yes	53	Programmable Pulse Generator 15
54	324	-	-	54	Reserved
55	320	-	-	55	Reserved
56	31C	-	-	56	Reserved
57	318	-	-	57	Reserved
58	314	RLT0	Yes	58	Reload Timer 0
59	310	RLT1	Yes	59	Reload Timer 1
60	30C	RLT2	Yes	60	Reload Timer 2
61	308	RLT3	Yes	61	Reload Timer 3
62	304	-	-	62	Reserved
63	300	-	-	63	Reserved
64	2FC	PPGRLT	Yes	64	Reload Timer 6 can be used as PPG clock source
65	2F8	ICU0	Yes	65	Input Capture Unit 0
66	2F4	ICU1	Yes	66	Input Capture Unit 1
67	2F0	ICU2	Yes	67	Input Capture Unit 2
68	2EC	ICU3	Yes	68	Input Capture Unit 3
69	2E8	ICU4	Yes	69	Input Capture Unit 4
70	2E4	ICU5	Yes	70	Input Capture Unit 5
71	2E0	ICU6	Yes	71	Input Capture Unit 6
72	2DC	ICU7	Yes	72	Input Capture Unit 7
73	2D8	-	-	73	Reserved
74	2D4	-	-	74	Reserved
75	2D0	-	-	75	Reserved
76	2CC	-	-	76	Reserved
77	2C8	OCU0	Yes	77	Output Compare Unit 0
78	2C4	OCU1	Yes	78	Output Compare Unit 1
79	2C0	OCU2	Yes	79	Output Compare Unit 2
80	2BC	OCU3	Yes	80	Output Compare Unit 3

Vector number	Offset in vector table	Vector name	Cleared by DMA	Index in ICR to program	Description
81	2B8	-	-	81	Reserved
82	2B4	-	-	82	Reserved
83	2B0	-	-	83	Reserved
84	2AC	-	-	84	Reserved
85	2A8	-	-	85	Reserved
86	2A4	-	-	86	Reserved
87	2A0	-	-	87	Reserved
88	29C	-	-	88	Reserved
89	298	FRT0	Yes	89	Free Running Timer 0
90	294	FRT1	Yes	90	Free Running Timer 1
91	290	-	-	91	Reserved
92	28C	-	-	92	Reserved
93	288	RTC0	No	93	Real Time Clock
94	284	CAL0	No	94	Clock Calibration Unit
95	280	-	-	95	Reserved
96	27C	IIC0	Yes	96	I <sup>2</sup> C interface0
97	278	-	-	97	Reserved
98	274	ADC0	Yes	98	A/D Converter
99	270	-	-	99	Reserved
100	26C	-	-	100	Reserved
101	268	LINR0	Yes	101	LIN USART 0 RX
102	264	LINT0	Yes	102	LIN USART 0 TX
103	260	LINR1	Yes	103	LIN USART 1 RX
104	25C	LINT1	Yes	104	LIN USART 1 TX
105	258	LINR2	Yes	105	LIN USART 2 RX
106	254	LINT2	Yes	106	LIN USART 2 TX
107	250	-	-	107	Reserved
108	24C	-	-	108	Reserved
109	248	LINR4	Yes	109	LIN USART 4 RX
110	244	LINT4	Yes	110	LIN USART 4 TX
111	240	LINR5	Yes	111	LIN USART 5 RX
112	23C	LINT5	Yes	112	LIN USART 5 TX
113	238	-	-	113	Reserved
114	234	-	-	114	Reserved
115	230	-	-	115	Reserved
116	22C	-	-	116	Reserved
117	228	-	-	117	Reserved
118	224	-	-	118	Reserved
119	220	-	-	119	Reserved
120	21C	-	-	120	Reserved

Vector number	Offset in vector table	Vector name	Cleared by DMA	Index in ICR to program	Description
121	218	-	-	121	Reserved
122	214	-	-	122	Reserved
123	210	-	-	123	Reserved
124	20C	-	-	124	Reserved
125	208	-	-	125	Reserved
126	204	-	-	126	Reserved
127	200	-	-	127	Reserved
128	1FC	-	-	128	Reserved
129	1F8	-	-	129	Reserved
130	1F4	-	-	130	Reserved
131	1F0	-	-	131	Reserved
132	1EC	-	-	132	Reserved
133	1E8	FLASHA	Yes	133	Flash memory A interrupt
134	1E4	-	-	134	Reserved
135	1E0	-	-	135	Reserved
136	1DC	-	-	136	Reserved
137	1D8	QPRC0	Yes	137	Quadrature Position/Revolution Counter 0
138	1D4	QPRC1	Yes	138	Quadrature Position/Revolution Counter 1
139	1D0	ADCRC0	No	139	A/D Converter 0 - Range Comparator
140	1CC	ADCPD0	No	140	A/D Converter 0 - Pulse detection
141	1C8	-	-	141	Reserved
142	1C4	-	-	142	Reserved
143	1C0	-	-	143	Reserved

## ■ HANDLING DEVICES

Special care is required for the following when handling the device:

- Latch-up prevention
- Unused pins handling
- External clock usage
- Notes on PLL clock mode operation
- Power supply pins ( $V_{CC}/V_{SS}$ )
- Crystal oscillator circuit
- Turn on sequence of power supply to A/D converter and analog inputs
- Pin handling when not using the A/D converter
- Notes on Power-on
- Stabilization of power supply voltage
- Serial communication

### 1. Latch-up prevention

CMOS IC chips may suffer latch-up under the following conditions:

- A voltage higher than  $V_{CC}$  or lower than  $V_{SS}$  is applied to an input or output pin.
- A voltage higher than the rated voltage is applied between  $V_{CC}$  pins and  $V_{SS}$  pins.
- The  $AV_{CC}$  power supply is applied before the  $V_{CC}$  voltage.

Latch-up may increase the power supply current dramatically, causing thermal damages to the device.

For the same reason, extra care is required to not let the analog power-supply voltage ( $AV_{CC}$ ,  $AVRH$ ) exceed the digital power-supply voltage.

### 2. Unused pins handling

Unused input pins can be left open when the input is disabled (corresponding bit of Port Input Enable register  $PIER = 0$ ).

Leaving unused input pins open when the input is enabled may result in misbehavior and possible permanent damage of the device. They must therefore be pulled up or pulled down through resistors. To prevent latch-up, those resistors should be more than 2 k $\Omega$ .

Unused bidirectional pins can be set either to the output state and be then left open, or to the input state with either input disabled or external pull-up/pull-down resistor as described above.

### 3. External clock usage

The permitted frequency range of an external clock depends on the oscillator type and configuration.

See AC Characteristics for detailed modes and frequency limits. Single and opposite phase external clocks must be connected as follows:

#### 1. Single phase external clock for Main oscillator

- When using a single phase external clock for the Main oscillator, X0 pin must be driven and X1 pin left open. And supply 1.8V power to the external clock.

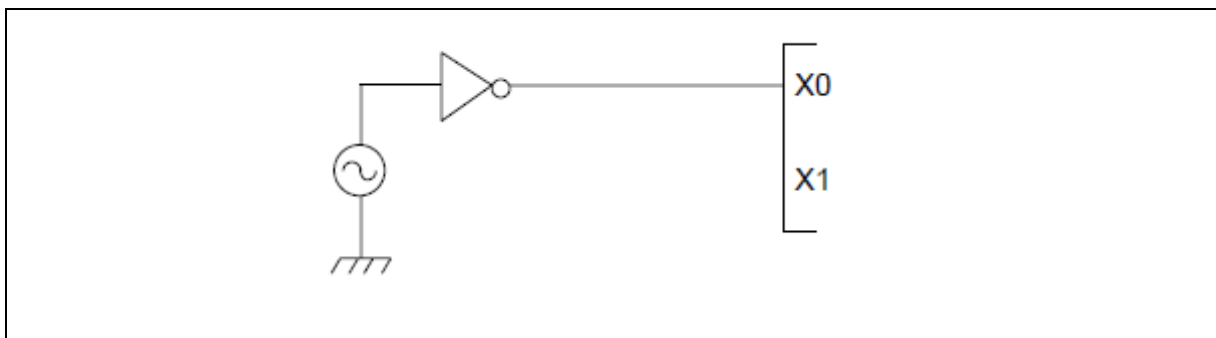

## 2. Single phase external clock for Sub oscillator

- When using a single phase external clock for the Sub oscillator, 'External clock mode' must be selected and X0A/GP04\_0 must be driven. X1A/GP04\_1 must be configured as GPIO.

## 4. Notes on PLL clock mode operation

If the PLL clock mode is selected and no external oscillator is operating or no external clock is supplied, the microcontroller attempts to work with the free oscillating PLL. Performance of this operation, however, cannot be guaranteed.

## 5. Power supply pins ( $V_{CC}/V_{SS}$ )

It is required that all  $V_{CC}$ -level as well as all  $V_{SS}$ -level power supply pins are at the same potential. If there is more than one  $V_{CC}$  or  $V_{SS}$  level, the device may operate incorrectly or be damaged even within the guaranteed operating range.

$V_{CC}$  and  $V_{SS}$  must be connected to the device from the power supply with lowest possible impedance.

As a measure against power supply noise, it is required to connect a bypass capacitor of about 0.1  $\mu\text{F}$  between  $V_{CC}$  and  $V_{SS}$  as close as possible to  $V_{CC}$  and  $V_{SS}$  pins.

## 6. Crystal oscillator and ceramic resonator circuit

Noise at X0, X1 pins or X0A, X1A pins might cause abnormal operation. It is required to provide bypass capacitors with shortest possible distance to X0, X1 pins and X0A, X1A pins, crystal oscillator (or ceramic resonator) and ground lines, and, to the utmost effort, that the lines of oscillation circuit do not cross the lines of other circuits.

It is highly recommended to provide a printed circuit board art work surrounding X0, X1 pins and X0A, X1A pins with a ground area for stabilizing the operation.

It is highly recommended to evaluate the quartz/MCU or resonator/MCU system at the quartz or resonator manufacturer, especially when using low-Q resonators at higher frequencies.

## 7. Turn on sequence of power supply to A/D converter and analog inputs

It is required to turn the A/D converter power supply ( $AV_{CC}$ ,  $AVRH$ ,  $AVRL$ ) and analog inputs ( $ANn$ ) on after turning the digital power supply ( $V_{CC}$ ) on.

It is also required to turn the digital power off after turning the A/D converter supply and analog inputs off. In this case, the voltage must not exceed  $AVRH$  or  $AV_{CC}$  (turning the analog and digital power supplies simultaneously on or off is acceptable).

## 8. Pin handling when not using the A/D converter

It is required to connect the unused pins of the A/D converter as  $AV_{CC} = V_{CC}$ ,  $AV_{SS} = AVRH = AVRL = V_{SS}$ .

## 9. Notes on Power-on

To prevent malfunction of the internal voltage regulator, supply voltage profile while turning the power supply on should be slower than 50 $\mu\text{s}$  from 0.2V to 2.7V.

## 10. Stabilization of power supply voltage

If the power supply voltage varies acutely even within the operation safety range of the  $V_{CC}$  power supply voltage, a malfunction may occur. The  $V_{CC}$  power supply voltage must therefore be stabilized. As stabilization guidelines, the power supply voltage must be stabilized in such a way that  $V_{CC}$  ripple fluctuations (peak to peak value) in the commercial frequencies (50 Hz to 60 Hz) fall within 10% of the standard  $V_{CC}$  power supply voltage and the transient fluctuation rate becomes 0.1V/ $\mu\text{s}$  or less in instantaneous fluctuation for power supply switching.

## **11. Serial communication**

There is a possibility to receive wrong data due to noise or other causes on the serial communication.

Therefore, design a printed circuit board so as to avoid noise.

Consider receiving of wrong data when designing the system. For example apply a checksum and retransmit the data if an error occurs.



## ■ ELECTRICAL CHARACTERISTICS

### 1. Absolute Maximum Ratings

Parameter	Symbol	Condition	Rating		Unit	Remarks
			Min	Max		
Power supply voltage* <sup>1</sup>	V <sub>CC</sub>	-	V <sub>SS</sub> - 0.3	V <sub>SS</sub> + 6.0	V	
Analog power supply voltage* <sup>1</sup>	AV <sub>CC</sub>	-	V <sub>SS</sub> - 0.3	V <sub>SS</sub> + 6.0	V	V <sub>CC</sub> = AV <sub>CC</sub> * <sup>2</sup>
Analog reference voltage* <sup>1</sup>	AV <sub>RH</sub> , AV <sub>RL</sub>	-	V <sub>SS</sub> - 0.3	V <sub>SS</sub> + 6.0	V	AV <sub>CC</sub> ≥ AV <sub>RH</sub> , AV <sub>CC</sub> ≥ AV <sub>RL</sub> , AV <sub>RH</sub> > AV <sub>RL</sub> , AV <sub>RL</sub> ≥ AV <sub>SS</sub>
LCD power supply voltage* <sup>1</sup>	V0 to V3	-	V <sub>SS</sub> - 0.3	V <sub>SS</sub> + 6.0	V	V0 to V3 must not exceed V <sub>CC</sub>
Input voltage* <sup>1</sup>	V <sub>I</sub>	-	V <sub>SS</sub> - 0.3	V <sub>SS</sub> + 6.0	V	V <sub>I</sub> ≤ V <sub>CC</sub> + 0.3V* <sup>3</sup>
Output voltage* <sup>1</sup>	V <sub>O</sub>	-	V <sub>SS</sub> - 0.3	V <sub>SS</sub> + 6.0	V	V <sub>O</sub> ≤ V <sub>CC</sub> + 0.3V* <sup>3</sup>
Maximum Clamp Current	I <sub>CLAMP</sub>	-	-4.0	+4.0	mA	Applicable to general purpose I/O pins * <sup>4</sup>
Total Maximum Clamp Current	Σ I <sub>CLAMP</sub>	-	-	32	mA	Applicable to general purpose I/O pins * <sup>4</sup>
"L" level maximum output current	I <sub>OL</sub>	-	-	15	mA	
"L" level average output current	I <sub>OLAV</sub>	-	-	4	mA	
"L" level maximum overall output current	ΣI <sub>OL</sub>	-	-	80	mA	
"L" level average overall output current	ΣI <sub>OLAV</sub>	-	-	40	mA	
"H" level maximum output current	I <sub>OH</sub>	-	-	-15	mA	
"H" level average output current	I <sub>OHAV</sub>	-	-	-4	mA	
"H" level maximum overall output current	ΣI <sub>OH</sub>	-	-	-80	mA	
"H" level average overall output current	ΣI <sub>OHAV</sub>	-	-	-40	mA	
Power consumption* <sup>5</sup>	P <sub>D</sub>	T <sub>A</sub> =+125°C	-	446 * <sup>6</sup>	mW	
Operating ambient temperature	T <sub>A</sub>	-	-40	125 * <sup>7</sup>	°C	
Storage temperature	T <sub>STG</sub>	-	-55	150	°C	

- \*1: This parameter is based on  $V_{SS} = AV_{SS} = 0V$ .
- \*2:  $AV_{CC}$  and  $V_{CC}$  must be set to the same voltage. It is required that  $AV_{CC}$  does not exceed  $V_{CC}$  and that the voltage at the analog inputs does not exceed  $AV_{CC}$  when the power is switched on.
- \*3:  $V_I$  and  $V_O$  should not exceed  $V_{CC} + 0.3 V$ .  $V_I$  should also not exceed the specified ratings. However if the maximum current to/from an input is limited by some means with external components, the  $I_{CLAMP}$  rating supersedes the  $V_I$  rating. Input/output voltages of standard ports depend on  $V_{CC}$ .
- \*4:
  - Applicable to all general purpose I/O pins (Pnn\_m).
  - Use within recommended operating conditions.
  - Use at DC voltage (current).
  - The +B signal should always be applied a limiting resistance placed between the +B signal and the microcontroller.
  - The value of the limiting resistance should be set so that when the +B signal is applied the input current to the microcontroller pin does not exceed rated values, either instantaneously or for prolonged periods.
  - Note that when the microcontroller drive current is low, such as in the power saving modes, the +B input potential may pass through the protective diode and increase the potential at the  $V_{CC}$  pin, and this may affect other devices.
  - Note that if a +B signal is input when the microcontroller power supply is off (not fixed at 0V), the power supply is provided from the pins, so that incomplete operation may result.
  - Note that if the +B input is applied during power-on, the power supply is provided from the pins and the resulting supply voltage may not be sufficient to operate the Power reset (except devices with persistent low voltage reset in internal vector mode).

• Sample recommended circuits:

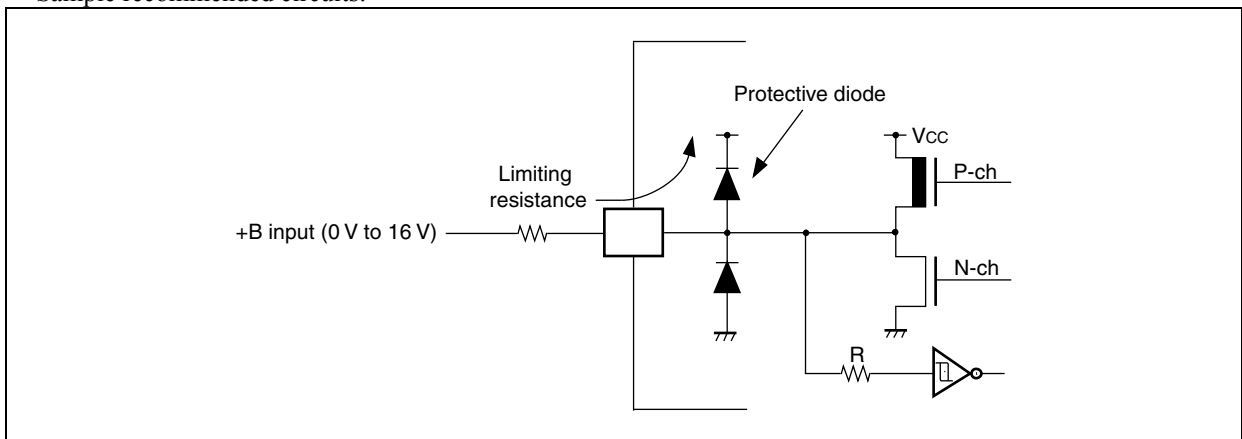

- \*5: The maximum permitted power dissipation depends on the ambient temperature, the air flow velocity and the thermal conductance of the package on the PCB.  
The actual power dissipation depends on the customer application and can be calculated as follows:  

$$P_D = P_{IO} + P_{INT}$$

$$P_{IO} = \sum (V_{OL} \times I_{OL} + V_{OH} \times I_{OH})$$
 (I/O load power dissipation, sum is performed on all I/O ports)  

$$P_{INT} = V_{CC} \times (I_{CC} + I_A)$$
 (internal power dissipation)  
 $I_{CC}$  is the total core current consumption into  $V_{CC}$  as described in the “DC characteristics” and depends on the selected operation mode and clock frequency and the usage of functions like Flash programming.  
 $I_A$  is the analog current consumption into  $AV_{CC}$ .
- \*6: Worst case value for a package mounted on single layer PCB at specified  $T_A$  without air flow.
- \*7: Write/erase to a large sector in flash memory is warranted with  $T_A \leq +105^\circ C$ .

**WARNING:** Semiconductor devices can be permanently damaged by application of stress (voltage, current, temperature, etc.) in excess of absolute maximum ratings. Do not exceed these ratings.

## 2. Recommended Operating Conditions

 $(V_{SS} = AV_{SS} = 0V)$ 

Parameter	Symbol	Value			Unit	Remarks
		Min	Typ	Max		
Power supply voltage	V <sub>cc</sub>	2.7	-	5.5	V	
Smoothing capacitor at C pin	C <sub>s</sub>	0.5	1.0	1.5	μF	(Target value) 1.0μF (Allowance within ± 50%) Please use the ceramic capacitor or the capacitor of the frequency response of this level. The smoothing capacitor at V <sub>CC</sub> must use the one of a capacity value that is larger than C <sub>s</sub> .

**WARNING:** The recommended operating conditions are required in order to ensure the normal operation of the semiconductor device. All of the device's electrical characteristics are warranted when the device is operated within these ranges.

Always use semiconductor devices within their recommended operating condition ranges.

Operation outside these ranges may adversely affect reliability and could result in device failure.

No warranty is made with respect to uses, operating conditions, or combinations not represented on the data sheet. Users considering application outside the listed conditions are advised to contact their representatives beforehand.

### 3. DC Characteristics

#### 1. Current rating of MB96F6C0

( $V_{CC} = AV_{CC} = 2.7V$  to  $5.5V$ ,  $V_{SS} = AV_{SS} = 0V$ ,  $T_A = -40^{\circ}C$  to  $+125^{\circ}C$ )

Parameter	Symbol	Pin name	Conditions	Value			Unit	Remarks
				Min	Typ	Max		
Power supply current in Run modes* <sup>1</sup>	I <sub>CCPLL</sub>	V <sub>CC</sub>	PLL Run mode with CLKS1/2 = CLKB = CLKP1/2 = 32MHz (CLKRC and CLKSC stopped)	-	28.5	-	mA	T <sub>A</sub> = +25°C
				-	-	38	mA	T <sub>A</sub> = +105°C (Target value)
				-	-	39.5	mA	T <sub>A</sub> = +125°C (Target value)
	I <sub>CCMAIN</sub>		Main Run mode with CLKS1/2 = CLKB = CLKP1/2 = 4MHz (CLKPLL, CLKSC and CLKRC stopped)	-	5	-	mA	T <sub>A</sub> = +25°C
				-	-	10	mA	T <sub>A</sub> = +105°C (Target value)
				-	-	11.5	mA	T <sub>A</sub> = +125°C (Target value)
	I <sub>CCSUB</sub>		Sub Run mode with CLKS1/2 = CLKB = CLKP1/2 = 32kHz (CLKMC, CLKPLL and CLKRC stopped)	-	0.5	-	mA	T <sub>A</sub> = +25°C
				-	-	6	mA	T <sub>A</sub> = +105°C (Target value)
				-	-	7.5	mA	T <sub>A</sub> = +125°C (Target value)
Power supply current in Sleep modes* <sup>1</sup>	I <sub>CCSPLL</sub>	V <sub>CC</sub>	PLL Sleep mode with CLKS1/2 = CLKP1/2 = 32MHz (CLKRC and CLKSC stopped)	-	10	-	mA	T <sub>A</sub> = +25°C
				-	-	15	mA	T <sub>A</sub> = +105°C (Target value)
				-	-	16.5	mA	T <sub>A</sub> = +125°C (Target value)
	I <sub>CCSMAN</sub>		Main Sleep mode with CLKS1/2 = CLKP1/2 = 4MHz (CLKPLL, CLKRC and CLKSC stopped)	-	3	-	mA	T <sub>A</sub> = +25°C
				-	-	8	mA	T <sub>A</sub> = +105°C (Target value)
				-	-	9.5	mA	T <sub>A</sub> = +125°C (Target value)
	I <sub>CCSSUB</sub>		Sub Sleep mode with CLKS1/2 = CLKP1/2 = 32kHz, (CLKMC, CLKPLL and CLKRC stopped)	-	0.3	-	mA	T <sub>A</sub> = +25°C
				-	-	4.5	mA	T <sub>A</sub> = +105°C (Target value)
				-	-	6	mA	T <sub>A</sub> = +125°C (Target value)

(V<sub>CC</sub> = AV<sub>CC</sub> = 2.7V to 5.5V, V<sub>SS</sub> = AV<sub>SS</sub> = 0V, T<sub>A</sub> = -40°C to +125°C)

Parameter	Symbol	Pin name	Conditions	Value			Unit	Remarks
				Min	Typ	Max		
Power supply current in Timer modes*2	I <sub>CCTMAIN</sub>	V <sub>CC</sub>	Main Timer mode with CLKMC = 4MHz (CLKPLL, CLKRC and CLKSC stopped)	-	285	355	μA	T <sub>A</sub> = +25°C
				-	-	1320	μA	T <sub>A</sub> = +105°C (Target value)
				-	-	2300	μA	T <sub>A</sub> = +125°C (Target value)
	I <sub>CCTRCH</sub>		RC Timer mode with CLKRC = 2MHz	-	160	245	μA	T <sub>A</sub> = +25°C
				-	-	1230	μA	T <sub>A</sub> = +105°C (Target value)
				-	-	2205	μA	T <sub>A</sub> = +125°C (Target value)
	I <sub>CCTRCL</sub>		RC Timer mode with CLKRC = 100kHz	-	35	105	μA	T <sub>A</sub> = +25°C
				-	-	1030	μA	T <sub>A</sub> = +105°C (Target value)
				-	-	2005	μA	T <sub>A</sub> = +125°C (Target value)
	I <sub>CCTSUB</sub>		Sub Timer mode with CLKSC = 32kHz (CLKMC, CLKPLL and CLKRC stopped)	-	25	90	μA	T <sub>A</sub> = +25°C
				-	-	1000	μA	T <sub>A</sub> = +105°C (Target value)
				-	-	1980	μA	T <sub>A</sub> = +125°C (Target value)
Power supply current in Stop mode*3	I <sub>CCH</sub>	-	20	90	μA	T <sub>A</sub> = +25°C		
		-	-	1000	μA	T <sub>A</sub> = +105°C (Target value)		
		-	-	1980	μA	T <sub>A</sub> = +125°C (Target value)		
Power supply current for active Low Voltage detector*4	I <sub>CCLVD</sub>		Low voltage detector enabled	-	5	15	μA	
Flash Write/ Erase current*5	I <sub>CCFLASH</sub>		-	-	12.5	20	mA	

\*1: The power supply current is measured with a 4MHz external clock connected to the Main oscillator and a 32kHz external clock connected to the Sub oscillator. See chapter "Standby mode and voltage regulator control circuit" of the Hardware Manual for further details about voltage regulator control. Power supply for "On Chip Debugger" part is not included. Power supply current in Run mode does not include Flash Write / Erase current.

\*2: The power supply current in Timer mode is the value when Flash is in Power-down / reset mode. The power supply current is measured with a 4MHz external clock connected to the Main oscillator and a 32kHz external clock connected to the Sub oscillator.

\*3: The power supply current in Stop mode is the value when Flash is in Power-down / reset mode.

\*4: When low voltage detector is enabled, I<sub>CCLVD</sub> must be added to Power supply current.

\*5: When Flash Write / Erase program is executed, I<sub>CCFLASH</sub> must be added to Power supply current.

## 2. Pin characteristics

( $V_{CC} = AV_{CC} = 2.7V$  to  $5.5V$ ,  $V_{SS} = AV_{SS} = 0V$ ,  $T_A = -40^{\circ}C$  to  $+125^{\circ}C$ )

Parameter	Symbol	Pin name	Conditions	Value			Unit	Remarks
				Min	Typ	Max		
"H" level input voltage	$V_{IH}$	Port inputs Pnn_m	-	$V_{CC} \times 0.7$	-	$V_{CC} + 0.3$	V	CMOS Hysteresis input
			-	$V_{CC} \times 0.8$	-	$V_{CC} + 0.3$	V	AUTOMOTIVE Hysteresis input
	$V_{IHX0S}$	X0	External clock in "oscillation mode"	$VD \times 0.8$	-	VD	V	VD=1.8V±0.15V
	$V_{IHX0AS}$	X0A	External clock in "oscillation mode"	$V_{CC} \times 0.8$	-	$V_{CC} + 0.3$	V	
	$V_{IHR}$	RSTX	-	$V_{CC} \times 0.8$	-	$V_{CC} + 0.3$	V	CMOS Hysteresis input
	$V_{IHM}$	MD	-	$V_{CC} - 0.3$	-	$V_{CC} + 0.3$	V	CMOS Hysteresis input
	$V_{IHD}$	DEBUG I/F	-	2.0	-	$V_{CC} + 0.3$	V	TTL Input
"L" level input voltage	$V_{IL}$	Port inputs Pnn_m	-	$V_{SS} - 0.3$	-	$V_{CC} \times 0.3$	V	CMOS Hysteresis input
			-	$V_{SS} - 0.3$	-	$V_{CC} \times 0.5$	V	AUTOMOTIVE Hysteresis input
	$V_{ILX0S}$	X0	External clock in "oscillation mode"	$V_{SS}$	-	$VD \times 0.2$	V	VD=1.8V±0.15V
	$V_{ILX0AS}$	X0A	External clock in "oscillation mode"	$V_{SS} - 0.3$	-	$V_{CC} \times 0.2$	V	
	$V_{ILR}$	RSTX	-	$V_{SS} - 0.3$	-	$V_{CC} \times 0.2$	V	CMOS Hysteresis input
	$V_{ILM}$	MD	-	$V_{SS} - 0.3$	-	$V_{SS} + 0.3$	V	CMOS Hysteresis input
	$V_{ILD}$	DEBUG I/F	-	$V_{SS} - 0.3$	-	0.8	V	TTL Input
"H" level output voltage*	$V_{OH4}$	4mA type	$4.5V \leq V_{CC} \leq 5.5V$ $I_{OH} = -4mA$	$V_{CC} - 0.5$	-	$V_{CC}$	V	
			$2.7V \leq V_{CC} < 4.5V$ $I_{OH} = -1.5mA$					
	$V_{OH3}$	3mA type	$4.5V \leq V_{CC} \leq 5.5V$ $I_{OH} = -3mA$	$V_{CC} - 0.5$	-	$V_{CC}$	V	
			$2.7V \leq V_{CC} < 4.5V$ $I_{OH} = -1.5mA$					
"L" level output voltage*	$V_{OL4}$	4mA type	$4.5V \leq V_{CC} \leq 5.5V$ $I_{OL} = +4mA$	-	-	0.4	V	
			$2.7V \leq V_{CC} < 4.5V$ $I_{OL} = +1.7mA$					
	$V_{OL3}$	3mA type	$2.7V \leq V_{CC} < 5.5V$ $I_{OL} = +3mA$	-	-	0.4	V	

Parameter	Symbol	Pin name	Conditions	Value			Unit	Remarks
				Min	Typ	Max		
Input leak current	I <sub>IL</sub>	Pnn_m	V <sub>SS</sub> < V <sub>I</sub> < V <sub>CC</sub> AV <sub>SS</sub> , AV <sub>RL</sub> < V <sub>I</sub> < AV <sub>CC</sub> , AV <sub>RH</sub>	- 1	-	1	μA	
		P08_m, P09_m, P10_m	V <sub>SS</sub> < V <sub>I</sub> < V <sub>CC</sub> AV <sub>SS</sub> , AV <sub>RL</sub> < V <sub>I</sub> < AV <sub>CC</sub> , AV <sub>RH</sub>	- 3	-	3	μA	
Total LCD leak current	Σ I <sub>ILCD</sub>	All SEG/ COM pin	V <sub>CC</sub> = 5.0V	-	0.5	10	μA	Maximum leakage current of all LCD pins
Internal LCD divide resistance	R <sub>LCD</sub>	Between V3 and V2, V2 and V1, V1 and V0	V <sub>CC</sub> = 5.0V	6.25	12.5	25	kΩ	
Pull-up resistance value	R <sub>PU</sub>	Pnn_m	V <sub>CC</sub> = 5.0V ±10%	25	50	100	kΩ	
Input capacitance	C <sub>IN</sub>	Other than V <sub>CC</sub> , V <sub>SS</sub> , AV <sub>CC</sub> , AV <sub>SS</sub> , AV <sub>RH</sub> , AV <sub>RL</sub> , P08_m, P09_m, P10_m	-	-	5	15	pF	
		P08_m, P09_m, P10_m	-	-	15	30	pF	

\*: I<sub>OH</sub> and I<sub>OL</sub> are target value.

## 4. AC Characteristics

### (1) Main Clock Input Characteristics

( $V_{CC} = AV_{CC} = 2.7V$  to  $5.5V$ ,  $V_D = 1.8V \pm 0.15V$ ,  $V_{SS} = AV_{SS} = 0V$ ,  $T_A = -40^\circ C$  to  $+125^\circ C$ )

Parameter	Symbol	Pin name	Value			Unit	Remarks
			Min	Typ	Max		
Input frequency	$f_C$	X0, X1	4	-	8	MHz	When using a crystal oscillator, PLL off
			-	-	8	MHz	When using an opposite phase external clock, PLL off
			4	-	8	MHz	When using a crystal oscillator or opposite phase external clock, PLL on
Input frequency	$f_{FCI}$	X0	-	-	16	MHz	When using a single phase external clock in "Fast Clock Input mode", PLL off
			4	-	16	MHz	When using a single phase external clock in "Fast Clock Input mode", PLL on
Input clock cycle	$t_{CYLH}$	-	62.5	-	-	ns	
Input clock pulse width	$P_{WH}, P_{WL}$	-	30	-	70	%	

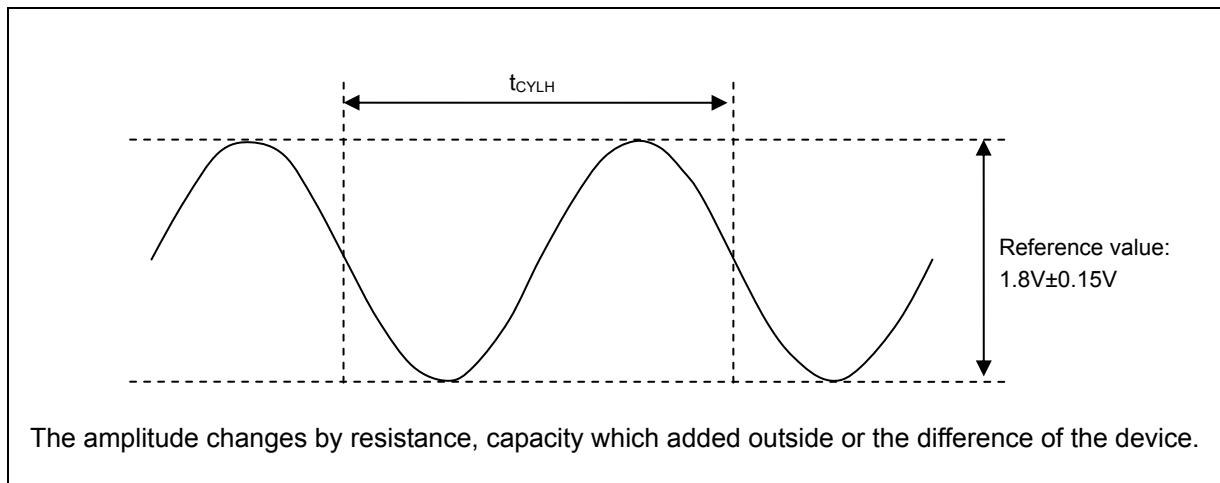



(2) Sub Clock Input Characteristics

( $V_{CC} = AV_{CC} = 2.7V$  to  $5.5V$ ,  $V_{SS} = AV_{SS} = 0V$ ,  $T_A = -40^{\circ}C$  to  $+125^{\circ}C$ )

Parameter	Symbol	Pin name	Conditions	Value			Unit	Remarks
				Min	Typ	Max		
Input frequency	$F_{CL}$	X0A, X1A	-	-	32.768	-	kHz	When using an oscillation circuit
			-	-	-	100		kHz
		X0A	-	-	-	50	kHz	When using a single phase external clock
Input clock cycle	$t_{CYLL}$	-	-	10	-	-	$\mu s$	
Input clock pulse width	-	-	$P_{WH}/t_{CYLL}$ $P_{WL}/t_{CYLL}$	30	-	70	%	

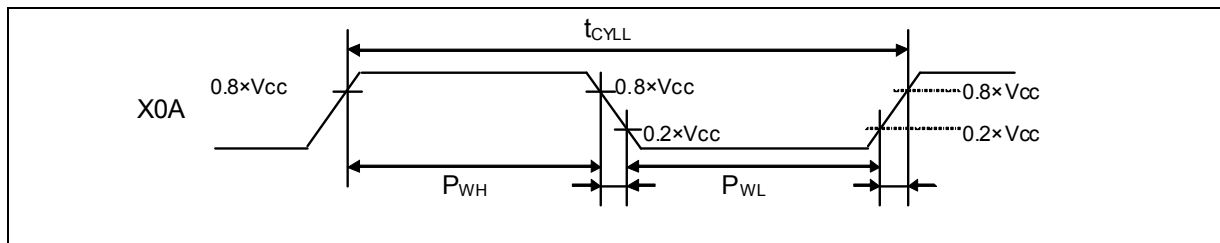

(3) Built-in RC Oscillation Characteristics

( $V_{CC} = AV_{CC} = 2.7V$  to  $5.5V$ ,  $V_{SS} = AV_{SS} = 0V$ ,  $T_A = -40^{\circ}C$  to  $+125^{\circ}C$ )

Parameter	Symbol	Value			Unit	Remarks
		Min	Typ	Max		
Clock frequency	$F_{RC}$	50	100	200	kHz	When using slow frequency of RC oscillator
		1	2	4		MHz

(4) Internal Clock timing

( $V_{CC} = AV_{CC} = 2.7V$  to  $5.5V$ ,  $V_{SS} = AV_{SS} = 0V$ ,  $T_A = -40^{\circ}C$  to  $+125^{\circ}C$ )

Parameter	Symbol	Value		Unit
		Min	Max	
Internal System clock frequency (CLKS1 and CLKS2)	$f_{CLKS1}, f_{CLKS2}$	-	54	MHz
Internal CPU clock frequency (CLKB), Internal peripheral clock frequency (CLKP1)	$f_{CLKB}, f_{CLKP1}$	-	32	MHz
Internal peripheral clock frequency (CLKP2)	$f_{CLKP2}$	-	32	MHz

### (5) Operating Conditions of PLL

( $V_{CC} = AV_{CC} = 2.7V$  to  $5.5V$ ,  $V_{SS} = AV_{SS} = 0V$ ,  $T_A = -40^{\circ}C$  to  $+125^{\circ}C$ )

Parameter	Symbol	Value			Unit	Remarks
		Min	Typ	Max		
PLL oscillation stabilization wait time (LOCK UP time)	$t_{LOCK}$	1	-	4	ms	Time from when the PLL starts operating until the oscillation stabilizes
PLL input clock frequency	$f_{PLL}$	4	-	16	MHz	
PLL macro oscillation clock frequency	$f_{PLO}$	56	-	108	MHz	

### (6) Reset Input Characteristics

( $V_{CC} = AV_{CC} = 2.7V$  to  $5.5V$ ,  $V_{SS} = AV_{SS} = 0V$ ,  $T_A = -40^{\circ}C$  to  $+125^{\circ}C$ )

Parameter	Symbol	Pin name	Value		Unit
			Min	Max	
Reset input time	$T_{RSTL}$	RSTX	10	-	$\mu s$
Rejection of reset input time			1	-	$\mu s$

### (7) Power-on Reset Timing

( $V_{CC} = AV_{CC} = 2.7V$  to  $5.5V$ ,  $V_{SS} = AV_{SS} = 0V$ ,  $T_A = -40^{\circ}C$  to  $+125^{\circ}C$ )

Parameter	Symbol	Value			Unit
		Min	Typ	Max	
Power on rise time	$T_r$	0.05	-	30	ms
Power off time	$T_{off}$	1	-	-	ms

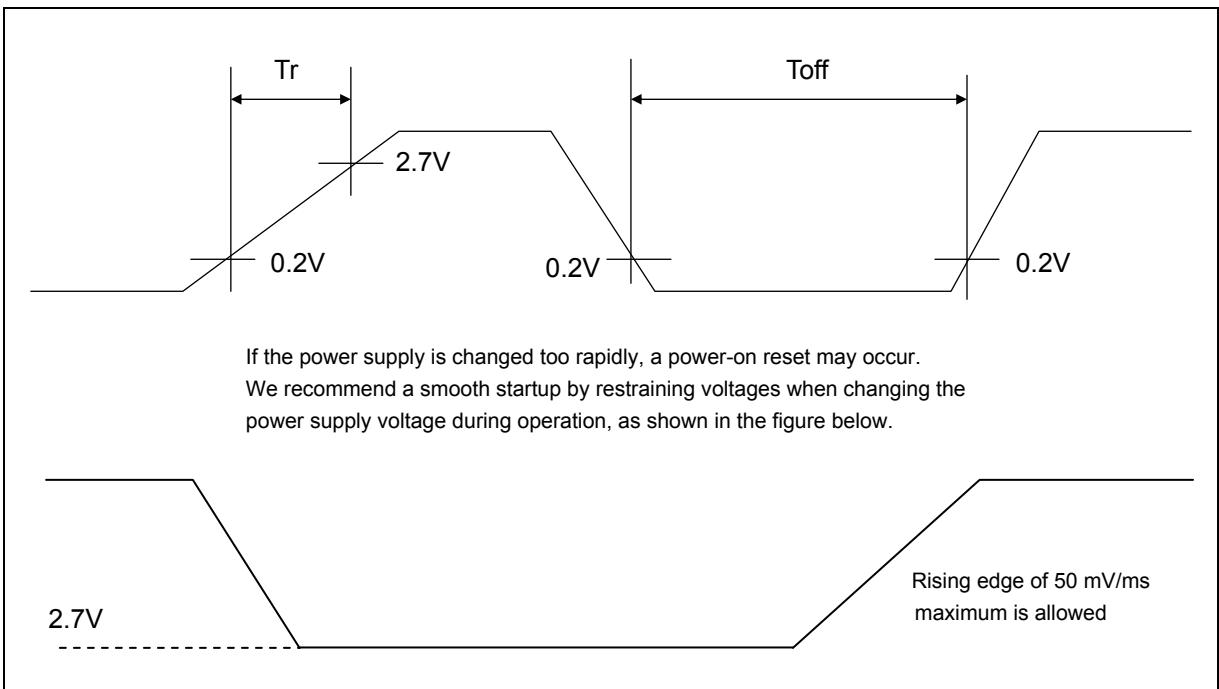

(8) USART Timing

( $V_{CC} = AV_{CC} = 2.7V$  to  $5.5V$ ,  $V_{SS} = AV_{SS} = 0V$ ,  $T_A = -40^{\circ}C$  to  $+125^{\circ}C$ )

Parameter	Symbol	Pin name	Conditions	4.5V ≤ V <sub>CC</sub> < 5.5V		2.7V ≤ V <sub>CC</sub> < 4.5V		Unit
				Min	Max	Min	Max	
Serial clock cycle time	tSCYC	SCK <sub>n</sub>	Internal shift clock operation	4 t <sub>CLKP1</sub>	-	4 t <sub>CLKP1</sub>	-	ns
SCK ↓ → SOT delay time	tSLOVI	SCK <sub>n</sub> SOT <sub>n</sub>		- 20	+ 20	- 30	+ 30	ns
SOT → SCK ↑ delay time	tOVSHI	SCK <sub>n</sub> SOT <sub>n</sub>		N × t <sub>CLKP1</sub> - 20*	-	N × t <sub>CLKP1</sub> - 30*	-	ns
SIN → SCK ↑ setup time	tIVSHI	SCK <sub>n</sub> SIN <sub>n</sub>		t <sub>CLKP1</sub> + 45	-	t <sub>CLKP1</sub> + 55	-	ns
SCK ↑ → SIN hold time	tSHIXI	SCK <sub>n</sub> SIN <sub>n</sub>		0	-	0	-	ns
Serial clock "L" pulse width	tSLSH	SCK <sub>n</sub>	External shift clock operation	t <sub>CLKP1</sub> + 10	-	t <sub>CLKP1</sub> + 10	-	ns
Serial clock "H" pulse width	tSHSL	SCK <sub>n</sub>		t <sub>CLKP1</sub> + 10	-	t <sub>CLKP1</sub> + 10	-	ns
SCK ↓ → SOT delay time	tSLOVE	SCK <sub>n</sub> SOT <sub>n</sub>		-	2 t <sub>CLKP1</sub> + 45	-	2 t <sub>CLKP1</sub> + 55	ns
SIN → SCK ↑ setup time	tIVSHE	SCK <sub>n</sub> SIN <sub>n</sub>		t <sub>CLKP1</sub> /2 + 10	-	t <sub>CLKP1</sub> /2 + 10	-	ns
SCK ↑ → SIN hold time	tSHIXE	SCK <sub>n</sub> SIN <sub>n</sub>		t <sub>CLKP1</sub> + 10	-	t <sub>CLKP1</sub> + 10	-	ns
SCK fall time	tF	SCK <sub>n</sub>		-	20	-	20	ns
SCK rise time	tR	SCK <sub>n</sub>	-	20	-	20	ns	

- Notes:
- The above characteristics apply to CLK synchronous mode.
  - C<sub>L</sub> is the load capacity value of pins when testing.
  - Depending on the used machine clock frequency, the maximum possible baud rate can be limited by some parameters. These parameters are shown in “MB966C0 series HARDWARE MANUAL”
  - t<sub>CLKP1</sub> indicates the peripheral clock 1 (CLKP1), Unit: ns
  - These characteristics only guarantee the same relocate port number.  
For example, the combination of SCLK<sub>n</sub>\_0 and SOT<sub>n</sub>\_1 is not guaranteed.

\*: Parameter N depends on tSCYC and can be calculated as follows:  
 • If tSCYC = 2 × k × t<sub>CLKP1</sub>, then N = k, where k is an integer > 2  
 • If tSCYC = (2 × k + 1) × t<sub>CLKP1</sub>, then N = k + 1, where k is an integer > 1

Examples:

tSCYC	N
4 × t <sub>CLKP1</sub>	2
5 × t <sub>CLKP1</sub> , 6 × t <sub>CLKP1</sub>	3
7 × t <sub>CLKP1</sub> , 8 × t <sub>CLKP1</sub>	4
...	...

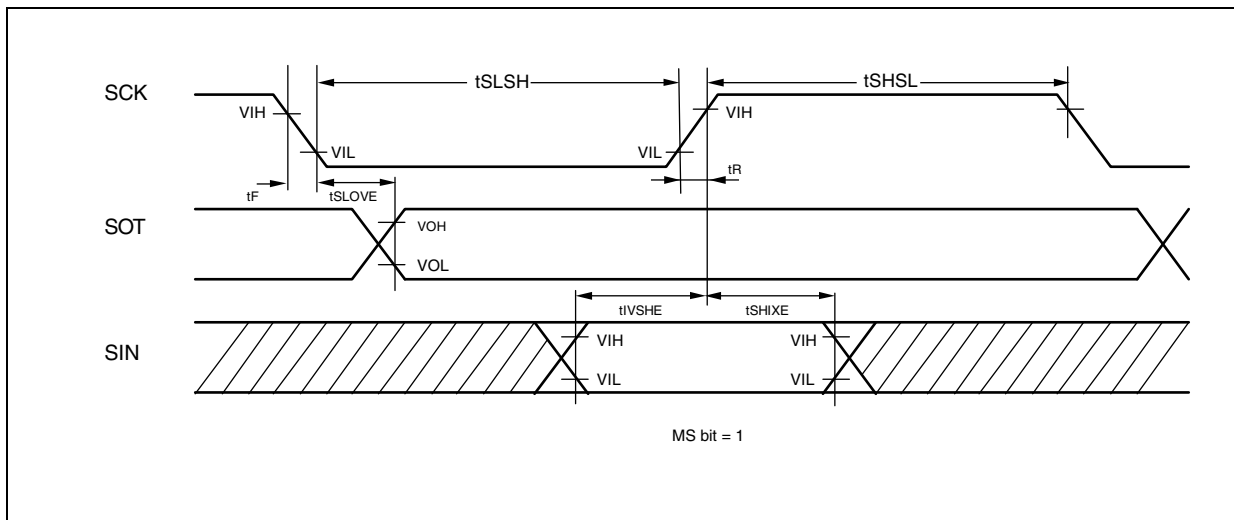
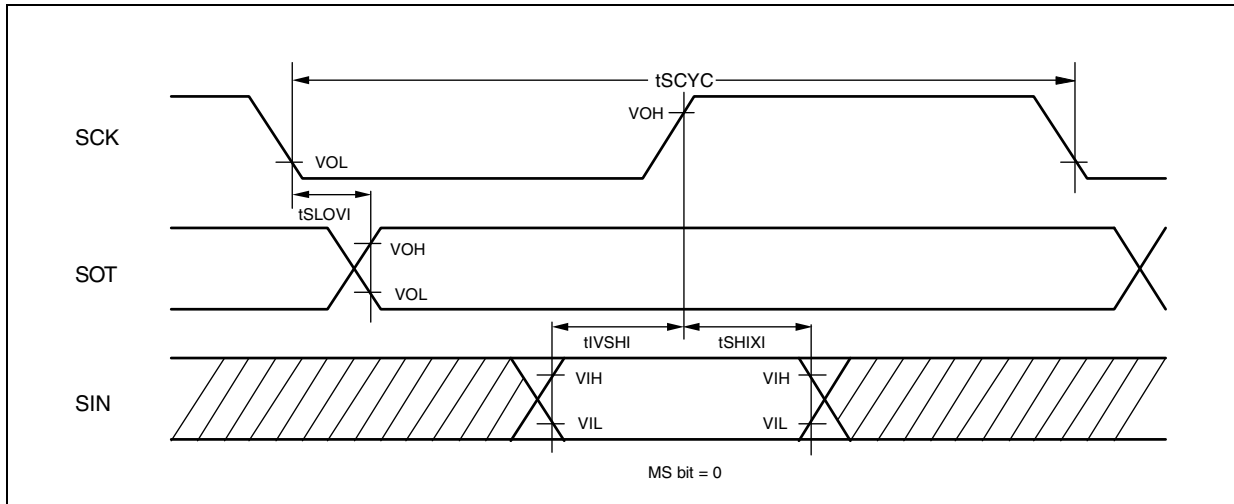

(9) External input timing

( $V_{CC} = AV_{CC} = 2.7V$  to  $5.5V$ ,  $V_{SS} = AV_{SS} = 0V$ ,  $T_A = -40^{\circ}C$  to  $+125^{\circ}C$ )

Parameter	Symbol	Pin name	Value		Unit	Remarks
			Min	Max		
Input pulse width	$t_{INH}$ $t_{INL}$	Pnn_m	$2t_{CLKP1} + 200$ ( $t_{CLKP1} = 1/f_{CLKP1}$ )*	-	ns	General Purpose I/O
		ADTG				A/D converter trigger input
		TINn, TINn_R				Reload Timer
		TTGn				PPG Trigger input
		FRCKn, FRCKn_R				Free-Running Timer input clock
		INn, INn_R				Input capture
		AINn, BINn, ZINn				Quadrature position/revolution counter
		INTn, INTn_R, NMI	200	-	ns	External interrupt NMI

\*:  $t_{CLKP1}$  indicates the peripheral clock1 (CLKP1) cycle time except stop when in stop mode.

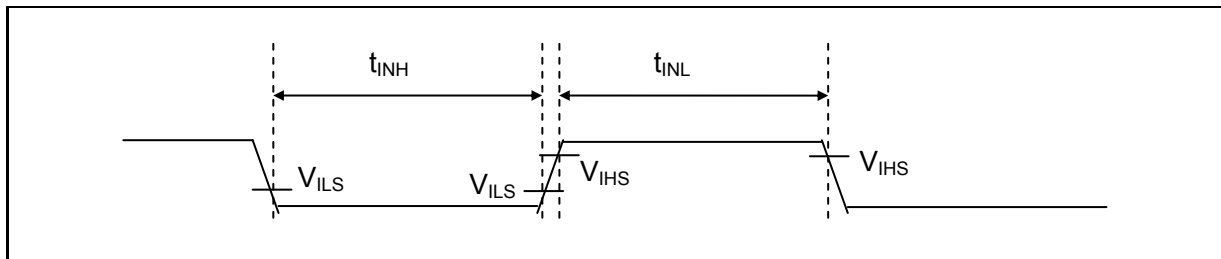

## (10) I<sup>2</sup>C timing

(V<sub>CC</sub> = AV<sub>CC</sub> = 2.7V to 5.5V, V<sub>SS</sub> = AV<sub>SS</sub> = 0V, T<sub>A</sub> = - 40°C to + 125°C)

Parameter	Symbol	Conditions	Typical mode		High-speed mode* <sup>4</sup>		Unit
			Min	Max	Min	Max	
SCL clock frequency	fSCL		0	100	0	400	kHz
(Repeated) START condition hold time SDA ↓ → SCL ↓	tHDSTA	CL = 50pF, R = (V <sub>p</sub> /I <sub>OL</sub> )* <sup>1</sup>	4.0	-	0.6	-	μs
SCL clock "L" width	tLOW		4.7	-	1.3	-	μs
SCL clock "H" width	tHIGH		4.0	-	0.6	-	μs
(Repeated) START setup time SCL ↑ → SDA ↓	tSUSTA		4.7	-	0.6	-	μs
Data hold time SCL ↓ → SDA ↓ ↑	tHDDAT		0	3.45* <sup>2</sup>	0	0.9* <sup>3</sup>	μs
Data setup time SDA ↓ ↑ → SCL ↑	tSUDAT		250	-	100	-	ns
STOP condition setup time SCL ↑ → SDA ↑	tSUSTO		4.0	-	0.6	-	μs
Bus free time between "STOP condition" and "START condition"	tBUS		4.7	-	1.3	-	μs

\*1: R and C represent the pull-up resistance and load capacitance of the SCL and SDA lines, respectively. V<sub>p</sub> indicates the power supply voltage of the pull-up resistance and I<sub>OL</sub> indicates V<sub>OL</sub> guaranteed current.

\*2: The maximum tHDDAT must satisfy that it doesn't extend at least "L" period (tLOW) of device's SCL signal.

\*3: A high-speed mode I<sup>2</sup>C bus device can be used on a standard mode I<sup>2</sup>C bus system as long as the device satisfies the requirement of "tSUDAT ≥ 250 ns".

\*4: t<sub>CLKP1</sub> is the peripheral clock1 (CLKP1) cycle time. To use I<sup>2</sup>C, set the peripheral bus clock at 6 MHz or more.

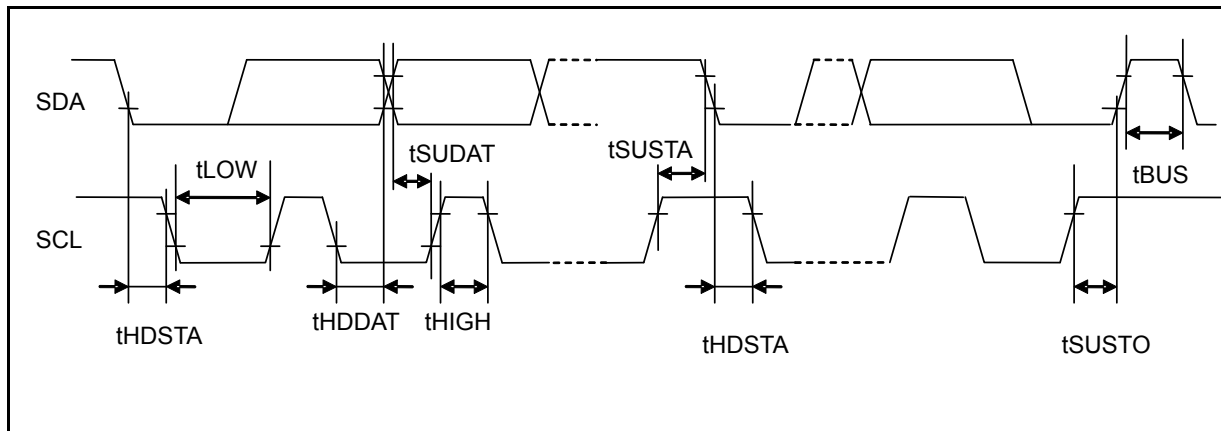

### ● 10bit A/D Converter

- Electrical characteristics for the A/D converter

( $V_{CC} = AV_{CC} = 2.7V$  to  $5.5V$ ,  $V_{SS} = AV_{SS} = 0V$ ,  $T_A = -40^{\circ}C$  to  $+125^{\circ}C$ )

Parameter	Symbol	Pin name	Value			Unit	Remarks
			Min	Typ	Max		
Resolution	-	-	-	-	10	bit	
Total error	-	-	- 3.0	-	+ 3.0	LSB	
Nonlinearity error	-	-	- 2.5	-	+ 2.5	LSB	
Differential Nonlinearity error	-	-	- 1.9	-	+ 1.9	LSB	
Zero transition voltage	$V_{OT}$	ANx	Typ - 20	AVRL + 0.5LSB	Typ + 20	mV	
Full transition voltage	$V_{FST}$	ANx	Typ - 20	AVRH - 1.5LSB	Typ + 20	mV	
Compare time	-	-	1.0	-	5.0	$\mu s$	$4.5V \leq AV_{CC} \leq 5.5V$
			2.2	-	8.0	$\mu s$	$2.7V \leq AV_{CC} < 4.5V$
Sampling time	-	-	0.5	-	-	$\mu s$	$4.5V \leq AV_{CC} \leq 5.5V$
			1.2	-	-	$\mu s$	$2.7V \leq AV_{CC} < 4.5V$
Power supply current	$I_A$	AV <sub>CC</sub>	-	2.0	3.1	mA	A/D Converter active
	$I_{AH}$		-	-	3.3	$\mu A$	A/D Converter not operated
Reference power supply current (between AVRH to AV <sub>SS</sub> )	$I_R$	AVRH	-	520	810	$\mu A$	A/D Converter active
	$I_{RH}$		-	-	1.0	$\mu A$	A/D Converter not operated
Analog input capacity	$C_{VIN}$	AN 0 to 15	-	-	16.0	pF	
		AN 16 to 31	-	-	17.8	pF	
Analog port input current	$I_{AIN}$	AN 0 to 15	- 0.3	-	+ 0.3	$\mu A$	$AV_{SS}, AVRL < V_{AIN} < AV_{CC}, AVRH$
		AN 16 to 31	- 3	-	+ 3	$\mu A$	
Analog input voltage	$V_{AIN}$	ANx	AVRL	-	AVRH	V	
Reference voltage range	-	AVRH	AV <sub>CC</sub> - 0.1	-	AV <sub>CC</sub>	V	
	-	AVRL	AV <sub>SS</sub>	-	AV <sub>SS</sub> + 0.1	V	

## Accuracy and setting of the A/D Converter sampling time

If the external impedance is too high or the sampling time too short, the analog voltage charged to the internal sample and hold capacitor is insufficient, adversely affecting the A/D conversion precision.

To satisfy the A/D conversion precision, a sufficient sampling time must be selected. The required sampling time depends on the external driving impedance  $R_{ext}$ , the board capacitance of the A/D converter input pin  $C_{ext}$  and the  $AV_{cc}$  voltage level. The following replacement model can be used for the calculation:

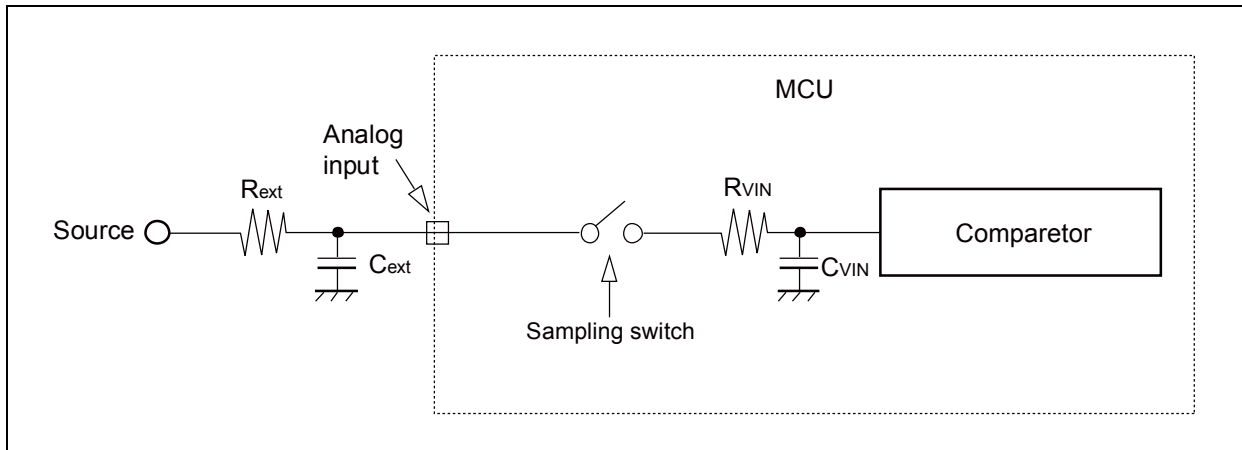

$R_{ext}$ : External driving impedance

$C_{ext}$ : Capacitance of PCB at A/D converter input

$C_{VIN}$ : Capacitance of MCU input pin (I/O, analog switch and ADC are contained)

16.0pF (Other than P08\_m, P09\_m, P10\_m), 17.8pF (P08\_m, P09\_m, P10\_m)

$R_{VIN}$ : Analog input impedance (I/O, analog switch and ADC are contained)

2050 $\Omega$  ( $4.5V \leq AV_{cc} \leq 5.5V$ ), 3600 $\Omega$  ( $2.7V \leq AV_{cc} < 4.5V$ )

The following approximation formula for the replacement model above can be used:

$$T_{smp} [\text{min}] = 7.62 \times (R_{ext} \times C_{ext} + (R_{ext} + R_{VIN}) \times C_{VIN})$$

- Do not select a sampling time below the absolute minimum permitted value.  
( $0.5\mu\text{s}$  for  $4.5V \leq AV_{cc} \leq 5.5V$ ,  $1.2\mu\text{s}$  for  $2.7V \leq AV_{cc} < 4.5V$ )
- If the sampling time cannot be sufficient, connect a capacitor of about  $0.1\mu\text{F}$  to the analog input pin.
- A big external driving impedance also adversely affects the A/D conversion precision due to the pin input leakage current  $I_{IL}$  (static current before the sampling switch) or the analog input leakage current  $I_{AIN}$  (total leakage current of pin input and comparator during sampling). The effect of the pin input leakage current  $I_{IL}$  cannot be compensated by an external capacitor.
- The accuracy gets worse as  $|AV_{RH} - AV_{RL}|$  becomes smaller.



• Definition of 10-bit A/D Converter Terms

- Resolution : Analog variation that is recognized by an A/D converter.
- Linearity error : Deviation of the line between the zero-transition point (0b0000000000 ←→ 0b0000000001) and the full-scale transition point (0b1111111110 ←→ 0b1111111111) from the actual conversion characteristics.
- Differential linearity error : Deviation from the ideal value of the input voltage that is required to change the output code by 1 LSB.
- Total error : Difference between the actual value and the theoretical value. The total error includes zero transition error, full-scale transition error, and linearity error.

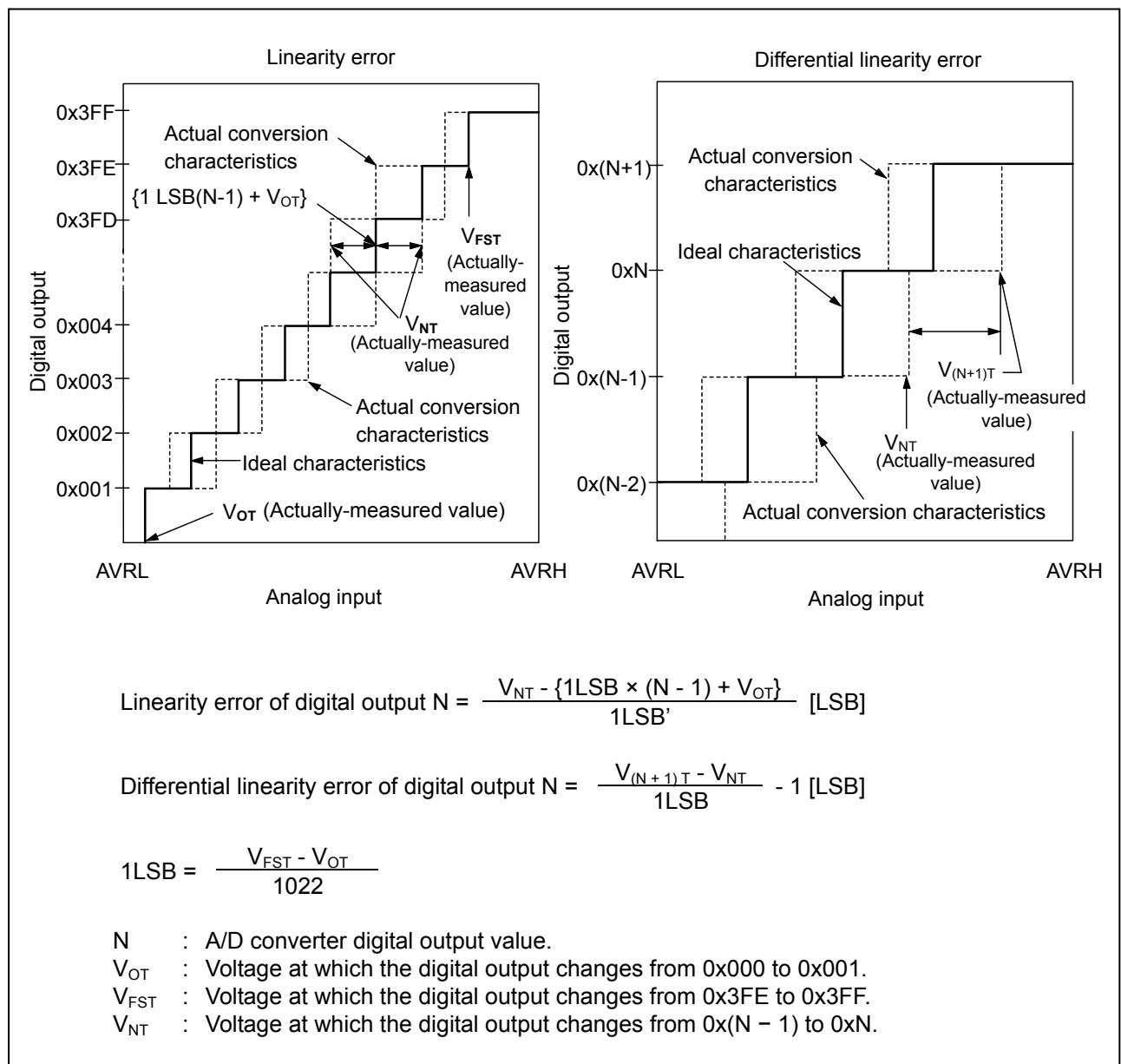

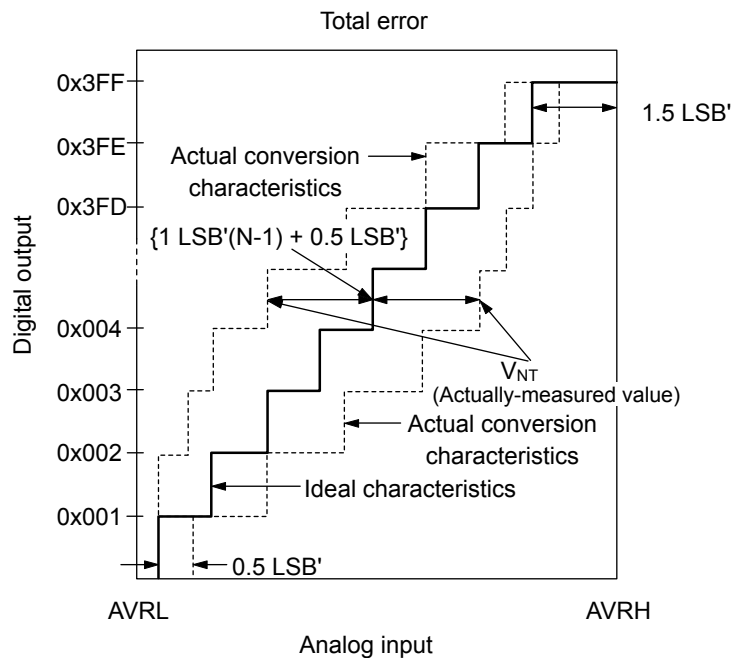

$$1\text{LSB}' \text{ (Ideal value)} = \frac{\text{AVRH} - \text{AVRL}}{1024} \text{ [V]}$$

$$\text{Total error of digital output } N = \frac{V_{\text{NT}} - \{1\text{LSB}' \times (N - 1) + 0.5\text{LSB}'\}}{1\text{LSB}'}$$

N : A/D converter digital output value.

$V_{\text{NT}}$  : Voltage at which the digital output changes from  $0x(N + 1)$  to  $0xN$ .

$V_{\text{OT}}'$  (Ideal value) =  $\text{AVRL} + 0.5\text{LSB}'$  [V]

$V_{\text{FST}}'$  (Ideal value) =  $\text{AVRH} - 1.5\text{LSB}'$  [V]

● Low voltage detection characteristics

( $V_{CC} = AV_{CC} = 2.7V$  to  $5.5V$ ,  $V_{SS} = AV_{SS} = 0V$ ,  $T_A = -40^{\circ}C$  to  $+125^{\circ}C$ )

Parameter	Symbol	Conditions	Value			Unit	Remarks
			Min	Typ	Max		
Detected voltage	VDL0	CILCR:LVL = 0000 <sub>B</sub>	2.70	2.90	3.10	V	
	VDL1	CILCR:LVL = 0001 <sub>B</sub>	2.79	3.00	3.21	V	
	VDL2	CILCR:LVL = 0010 <sub>B</sub>	2.98	3.20	3.42	V	
	VDL3	CILCR:LVL = 0011 <sub>B</sub>	3.26	3.50	3.74	V	
	VDL4	CILCR:LVL = 0100 <sub>B</sub>	3.45	3.70	3.95	V	
	VDL5	CILCR:LVL = 0111 <sub>B</sub>	3.73	4.00	4.27	V	
	VDL6	CILCR:LVL = 1001 <sub>B</sub>	3.91	4.20	4.49	V	
Change ration of power supply voltage	dV/dt	-	-0.004	-	-	V/ $\mu$ s	Detected voltage (VDL) must be within standards.

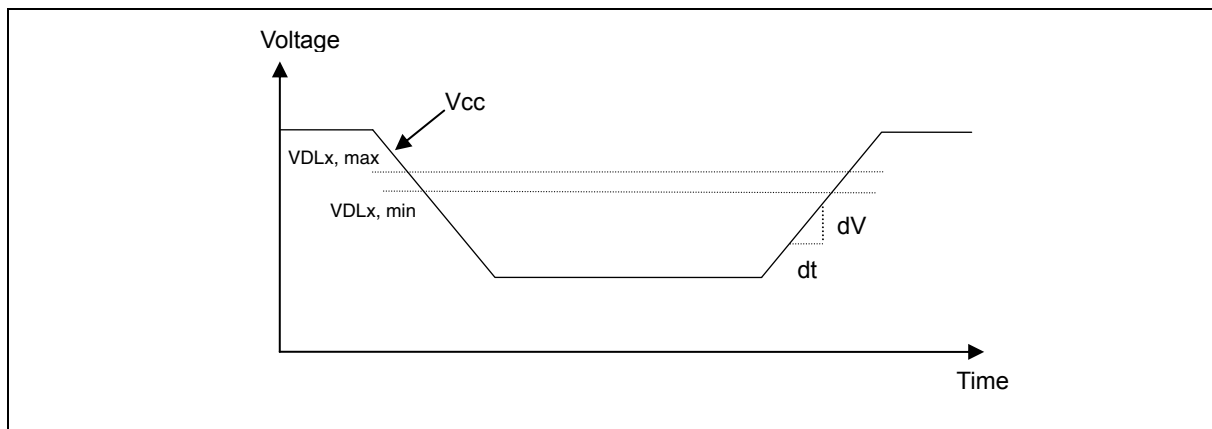

## ● Flash Memory Write/Erase Characteristics (Target Value)

( $V_{CC} = AV_{CC} = 2.7V$  to  $5.5V$ ,  $V_{SS} = AV_{SS} = 0V$ ,  $T_A = -40^{\circ}C$  to  $+125^{\circ}C$ )

Parameter		Value			Unit	Conditions	Remarks
		Min	Typ	Max			
Sector erase time	Large Sector	-	0.6	3.1	s	$T_A \leq +105^{\circ}C$	Excludes write time prior to internal erase
	Small Sector	-	0.3	1.6	s	-	
Half word (16 bit) write time	Large Sector	-	25	400	$\mu s$	$T_A \leq +105^{\circ}C$	Not including system-level overhead time.
	Small Sector	-	25	400	$\mu s$	-	
Chip erase time		-	2.7	14.2	s	$T_A \leq +105^{\circ}C$	Excludes write time prior to internal erase

Erase / write cycles and data hold time (targeted value)

Erase / write cycles (cycle)	Data hold time (year)
1,000	20 *
10,000	10 *
100,000	5 *

\*: This value comes from the technology qualification (using Arrhenius equation to translate high temperature measurements into normalized value at  $+85^{\circ}C$ ).

## ■ ORDERING INFORMATION

Part number	Flash memory	Package
MB96F6C6RAPMC-GSE1*	Flash A (288.5KB)	120-pin plastic LQFP (FPT-120P-M21)
MB96F6C6RAPMC-GSE2*		

\*: These devices are under development and specification is preliminary.  
These products under development may change its specification without notice.

## ■ PACKAGE DIMENSION

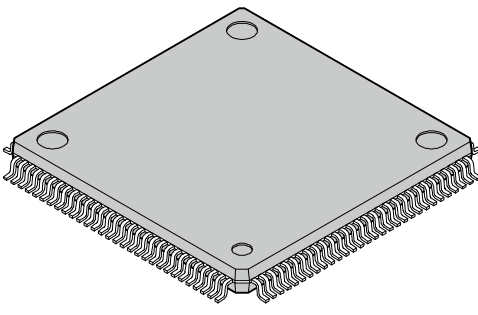
<p>120-pin plastic LQFP</p>  <p>(FPT-120P-M21)</p>	Lead pitch	0.50 mm
	Package width × package length	16.0 × 16.0 mm
	Lead shape	Gullwing
	Sealing method	Plastic mold
	Mounting height	1.70 mm MAX
	Weight	0.88 g
	Code (Reference)	P-LFQFP120-16×16-0.50

120-pin plastic LQFP (FPT-120P-M21)

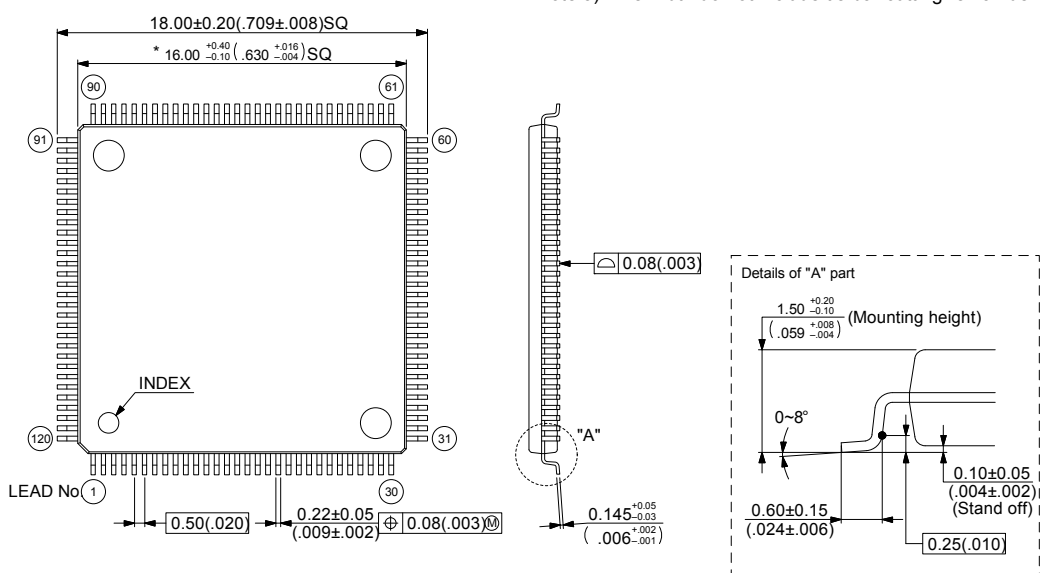

Note 1) \* : These dimensions do not include resin protrusion. Resin protrusion is +0.25(.010) MAX(each side).  
 Note 2) Pins width and pins thickness include plating thickness.  
 Note 3) Pins width do not include tie bar cutting remainder.

© 2002-2010 FUJITSU SEMICONDUCTOR LIMITED F120033S-c-4-7

Dimensions in mm (inches).  
 Note: The values in parentheses are reference values.

Please check the latest package dimension at the following URL.  
<http://edevic.fujitsu.com/package/en-search/>

**■ REVISION HISTORY**

Revision	Date	Modification
Prelim 1	31-Aug-2011	Creation

## FUJITSU SEMICONDUCTOR LIMITED

Nomura Fudosan Shin-yokohama Bldg. 10-23, Shin-yokohama 2-Chome,  
Kohoku-ku Yokohama Kanagawa 222-0033, Japan

Tel: +81-45-415-5858

<http://jp.fujitsu.com/fsl/en/>

*For further information please contact:*

### North and South America

FUJITSU SEMICONDUCTOR AMERICA, INC.

1250 E. Arques Avenue, M/S 333

Sunnyvale, CA 94085-5401, U.S.A.

Tel: +1-408-737-5600 Fax: +1-408-737-5999

<http://us.fujitsu.com/micro/>

### Asia Pacific

FUJITSU SEMICONDUCTOR ASIA PTE. LTD.

151 Lorong Chuan,

#05-08 New Tech Park 556741 Singapore

Tel : +65-6281-0770 Fax : +65-6281-0220

<http://sg.fujitsu.com/semiconductor/>

### Europe

FUJITSU SEMICONDUCTOR EUROPE GmbH

Pittlerstrasse 47, 63225 Langen, Germany

Tel: +49-6103-690-0 Fax: +49-6103-690-122

<http://emea.fujitsu.com/semiconductor/>

FUJITSU SEMICONDUCTOR SHANGHAI CO., LTD.

Rm. 3102, Bund Center, No.222 Yan An Road (E),

Shanghai 200002, China

Tel : +86-21-6146-3688 Fax : +86-21-6335-1605

<http://cn.fujitsu.com/fss/>

### Korea

FUJITSU SEMICONDUCTOR KOREA LTD.

902 Kosmo Tower Building, 1002 Daechi-Dong,

Gangnam-Gu, Seoul 135-280, Republic of Korea

Tel: +82-2-3484-7100 Fax: +82-2-3484-7111

<http://kr.fujitsu.com/fsk/>

FUJITSU SEMICONDUCTOR PACIFIC ASIA LTD.

10/F., World Commerce Centre, 11 Canton Road,

Tsimshatsui, Kowloon, Hong Kong

Tel : +852-2377-0226 Fax : +852-2376-3269

<http://cn.fujitsu.com/fsp/>

Specifications are subject to change without notice. For further information please contact each office.

### All Rights Reserved.

The contents of this document are subject to change without notice.

Customers are advised to consult with sales representatives before ordering.

The information, such as descriptions of function and application circuit examples, in this document are presented solely for the purpose of reference to show examples of operations and uses of FUJITSU SEMICONDUCTOR device; FUJITSU SEMICONDUCTOR does not warrant proper operation of the device with respect to use based on such information. When you develop equipment incorporating the device based on such information, you must assume any responsibility arising out of such use of the information.

FUJITSU SEMICONDUCTOR assumes no liability for any damages whatsoever arising out of the use of the information.

Any information in this document, including descriptions of function and schematic diagrams, shall not be construed as license of the use or exercise of any intellectual property right, such as patent right or copyright, or any other right of FUJITSU SEMICONDUCTOR or any third party or does FUJITSU SEMICONDUCTOR warrant non-infringement of any third-party's intellectual property right or other right by using such information. FUJITSU SEMICONDUCTOR assumes no liability for any infringement of the intellectual property rights or other rights of third parties which would result from the use of information contained herein.

The products described in this document are designed, developed and manufactured as contemplated for general use, including without limitation, ordinary industrial use, general office use, personal use, and household use, but are not designed, developed and manufactured as contemplated (1) for use accompanying fatal risks or dangers that, unless extremely high safety is secured, could have a serious effect to the public, and could lead directly to death, personal injury, severe physical damage or other loss (i.e., nuclear reaction control in nuclear facility, aircraft flight control, air traffic control, mass transport control, medical life support system, missile launch control in weapon system), or (2) for use requiring extremely high reliability (i.e., submersible repeater and artificial satellite).

Please note that FUJITSU SEMICONDUCTOR will not be liable against you and/or any third party for any claims or damages arising in connection with above-mentioned uses of the products.

Any semiconductor devices have an inherent chance of failure. You must protect against injury, damage or loss from such failures by incorporating safety design measures into your facility and equipment such as redundancy, fire protection, and prevention of over-current levels and other abnormal operating conditions.

Exportation/release of any products described in this document may require necessary procedures in accordance with the regulations of the Foreign Exchange and Foreign Trade Control Law of Japan and/or US export control laws.

The company names and brand names herein are the trademarks or registered trademarks of their respective owners.