

CSR BLUETOOTH MODULES

MBC05-CAR-AT

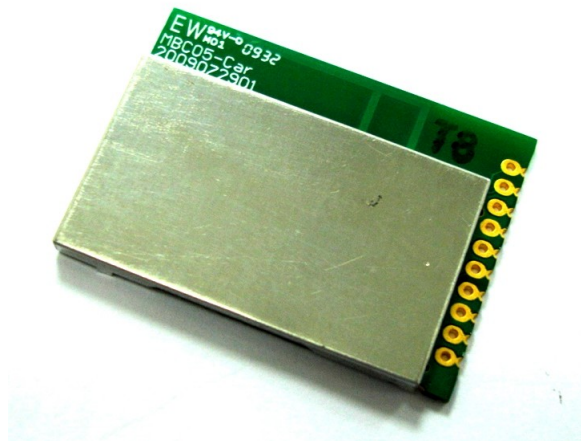

Specification

Version 0.1

25-Aug-2009

Product No.: MBC05-CAR-AT

Product Description:

Bluetooth v2.1 EDR Class 2 BT Stereo Module

Issue Date: 2009/08/25

Release Version: 0.1

Documentation History

Revision	Description	Date	Remark
V0.1	MBC05-CAR-AT	Aug 2009	

Content

Features.....	4
Hardware & Technical Information.....	5
Mechanical Specification.....	6
Reference Schematic.....	6
Electrical Characteristics.....	7
Software specification.....	9
Ordering Code.....	10

Features

CSR BlueCore05 Chip.

Bluetooth v2.1 EDR Compliant.

Bluetooth Class2 RF. Up to 10 meters transmission distance.

Supported A2DP, HFP, AVRCP, PBAP(Phone Book Access Profile) and Easy pairing.

Fully configurable with simple AT style commands over UART and Bluetooth connections.

On board printing antenna and external antenna versions.

Support Single End Audio output.

Dimension: 35X25X2.7mm.

Castellated SMT pads or 10 PIN pitch 2.0mm connector easy and reliable PCB mounting.

Description

MBC05-CAR-AT audio transmitter/Receiver is power by CSR BC05 technology. That provides a complete 2.4GHz

Bluetooth technology for stereo music transmission. The MBC05-CAR-AT module is compliant with Bluetooth specification v2.1 and support A2DP, AVRCP, HSP, HFP, OPP and PBAP(Phone Book Access Profile). It is the class 2 module with build in antenna. Reduce the effort on the RF section when the engineer designs it into the system. SmartDesign also customize the software to meet the requirement from customer.

Block Diagram

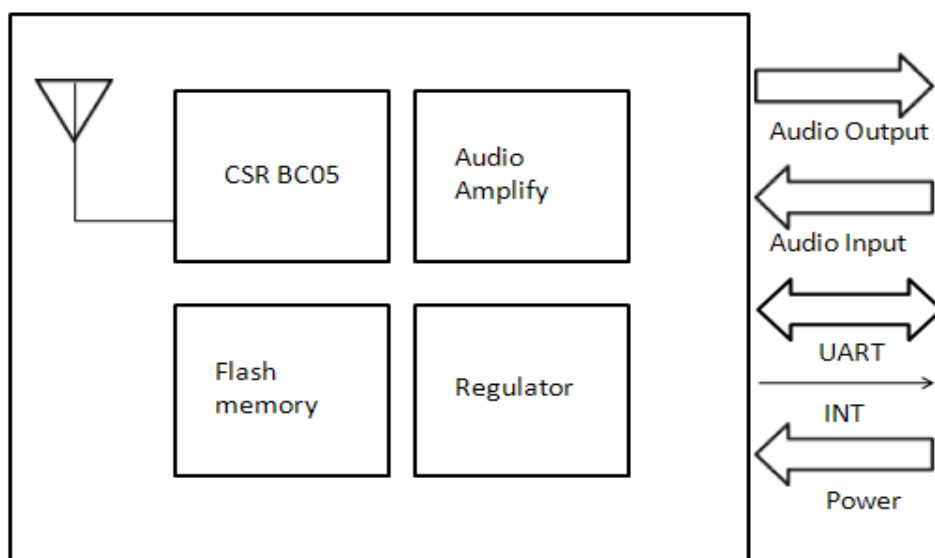

MBC05-CAR-AT Class2 Module Block Diagram

Hardware & Technical Information

Pin Definition

PIN	Name	Type	Note
1	L_SPK	O	Left side side audio output
2	R_SPK	O	Right side audio out put
3	SPK_GND	O	Ground for speaker
4	MIC+	I	Microphone +
5	MIC-	I	Microphone -
6	VCC	PWR	Power input
7	GND	PWR	Ground
8	TX	O	UART TX
9	RX	I	UART RX
10	INT	O	Interrupt
11	GND	PWR	Ground
12	GND	PWR	Ground
13	GND	PWR	Ground

VCC

Supply voltage at this pin with 5 V.

GND

Connect GND pins to the ground plane of the PCB.

RX

RX is used to implement UART data transfer from another device to MBC05-CAR-AT. The UART interface requires an external RS232 transceiver chip. TTL level.

TX

TX is used to implement UART data transfer from MBC05-CAR-AT to another device. TTL level.

L_SPK

Left channel audio output. The audio output line is the single-ended. Use low impedance ground plane dedicated for the audio signals.

R_SPK

Right channel audio output. The audio output line is the single-ended. Use low impedance ground plane dedicated for the audio signals

SPK_GND

Audio ground. Connect to right and left Audio line.

MIC+ and MIC-

Audio inputs. This audio input can be configured to microphone or line input. Route differential pairs close to each other and use a solid dedicated audio ground plane for the audio signals.

INT

Interrupt output. Normally keep in "Low". Change to "High" when Audio output.

Mechanical Specification

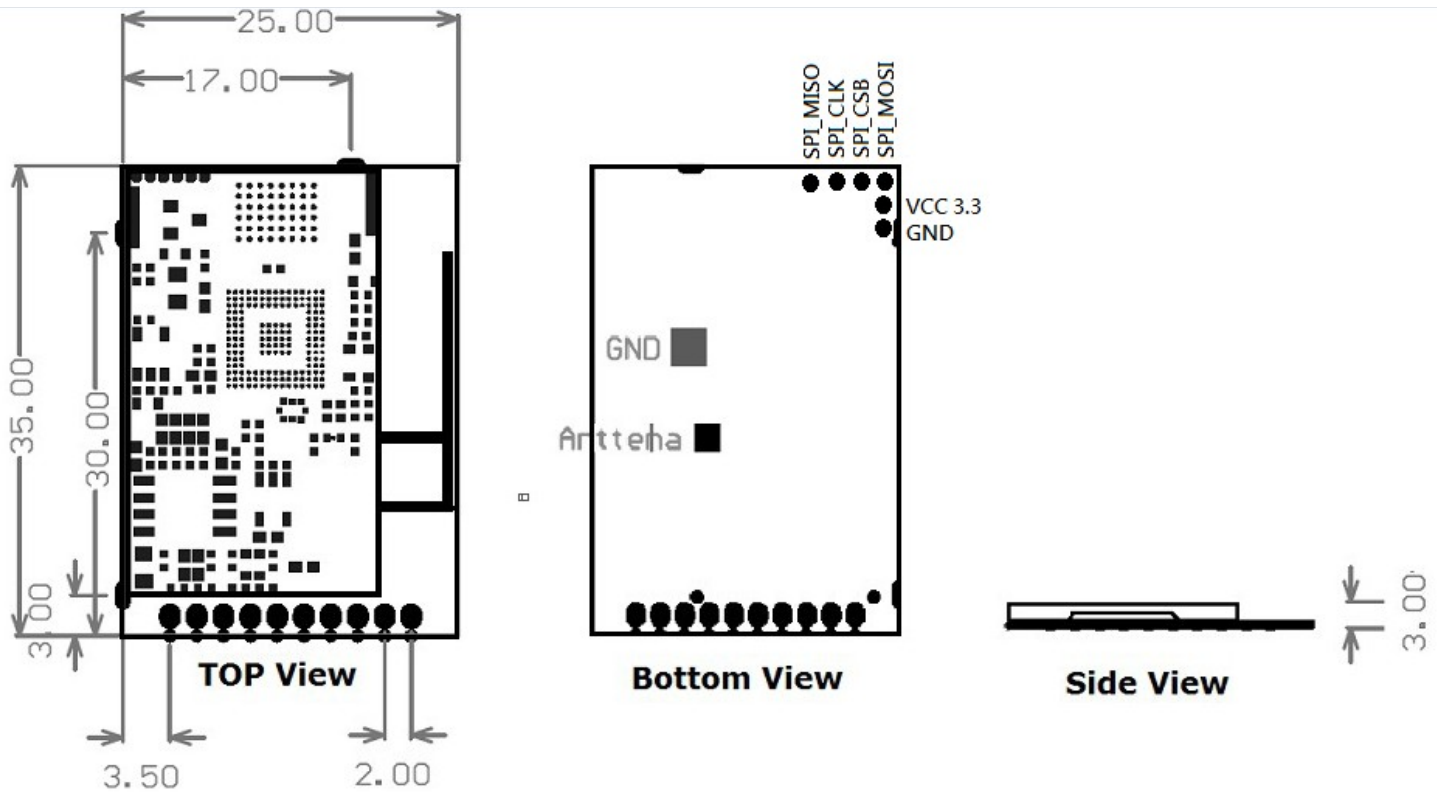

10 PINs Pitch 2.0

unit: mm

MBC05-CAR-AT CLASS2 Mechanical Specification

Reference Schematic

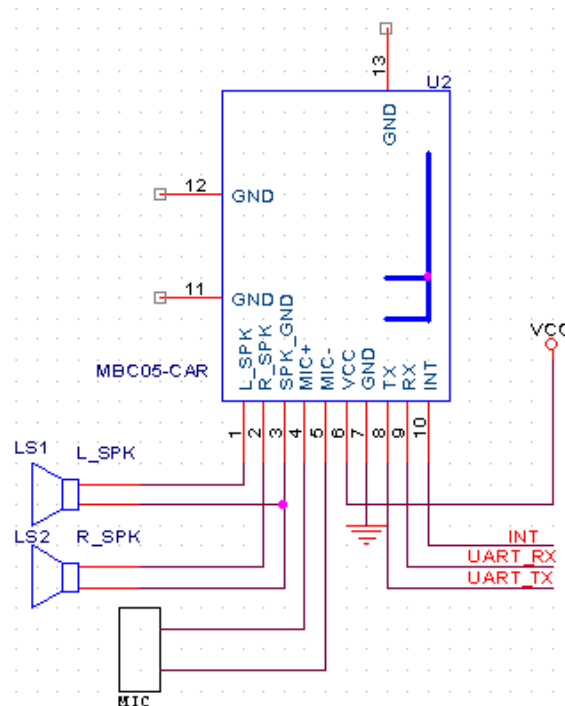

Electrical Characteristics

■ Voltage Input

	MIN	Typ.	MAX	Unit
Supply Voltage	3.5	5	5.3	V

■ Power Consumption

Mode	Avg.
Standby	10mA
HFP	26mA
A2DP	39mA
Link	11mA

■ Operating Conditions

Voltage Range	3.5-5.3V
Operating Temperature Range	-20°C ~ 70°C
Storage Temperature Range	-30°C ~ 80°C
Relative Humidity (Operating)	<=90%
Relative Humidity (Storage)	<=90%

Radio Characteristics

	Frequency (GHz)	MIN	TYP	MAX	BT Spec	Unit
Sensitivity at 0.1%BER	2.402	≤-84	-80	-	≤ -70	dBm
	2.441	≤-84	-80	-		dBm
	2.480	≤-84	-80	-		dBm
RF Transmit Power	2.402	-2	0	4	≤ 4	dBm
	2.441	-2	0	4		dBm
	2.480	-2	0	4		dBm
Initial Carrier Frequency Tolerance	2.402	-	5	75	75	kHz
	2.441	-	5	75		kHz
	2.480	-	5	75		kHz
20dB bandwidth for modulated carrier		-	900	1000	≤1000	kHz
Drift (Five slots packet)		-	15	-	40	kHz
Drift Rate		-	13	-	20	kHz
$\Delta f1_{avg}$ "Maximum Modulation"	2.402	140	165	175	140 < $\Delta f1_{avg}$	kHz
	2.441	140	165	175		kHz
	2.480	140	165	175		kHz
$\Delta f2_{max}$ "Minimum Modulation"	2.402	115	190	-	115	kHz
	2.441	115	190	-		kHz
	2.480	115	190	-		kHz

Software specification

Profile

Stack / Profile	MBC05-CAR-AT0 (Class2 BT2.0)	MBC05-CAR-ATP (Class2 BT2.0)
A2DP	V	V
HFP	V	V
AVRCP	V	V
PBAP		V

Software function

MBC05-CAR-AT will act only when you send AT command. Detailed AT command, please check the document “A2DP_AT_Commands” or “MBC05_CAR_AT_PBAP_Commands_20100706” .

Default setting Information

	Parameter	Value
1	Baud Rate	9600
2	Pin Code Prompt	0000
3	Local Name	MBC05-CAR
4	SYNC/AG	SYNC module

Customization Information

	Parameter	Value
1	Baud Rate	
2	Pin Code Prompt	
3	Local Name	
5		

Ordering Code

Order code	Description	Remark
MBC05-CAR-AT0	MBC05-CAR-AT with A2DP, HFP, AVRCP profile	
MBC05-CAR-ATP	MBC05-CAR-AT with A2DP, HFP, AVRCP, PBAP profile	