

# MBC100 Modular Bipolar Chopper Driver

- Bipolar Chopper Driver with Selectable Output Current from 200mA to 1A
- Half-step and Full-step Operation
- Automatic Standstill Current Reduction
- Two User-selectable Standstill Current Reduction Options: 66% and 33%
- ON/OFF Input to Control Motor without Powering Down the Driver
- Unit Operates From a Single, 8VDC - 40VDC Supply
- Clock Indicator Allows Visual Confirmation that Step Signals are Being Received
- DB9 Connectors for Inputs and Outputs
- Operation at Step Clock Speeds up to 10kHz
- Flexible Package Allows for Horizontal and Vertical Mounting



The MBC100 is a low-cost bipolar chopper driver designed to drive four-phase step motors rated up to 1A. The MBC100 is compact and self-contained, requiring only an 8VDC - 40VDC power source and clock input to operate. The maximum motor current can be adjusted from 200mA to 1A, by adjusting a potentiometer on the unit; *no external resistors are required to set the current level*. The inputs to the driver are of the sinking type for easy interfacing with other equipment. An ON/OFF input is provided, which allows the motor to be turned off without powering down the driver. The Halfstep/Fullstep input selects half-step or full-step operation. A direction input is also provided. When the motor has been at standstill for 2 seconds, the driver will enter a reduced current mode. The user can select the standstill reduced current to be 100% (no reduction), 66%, or 33% of the selected current level. A clock indicator is lit while clock inputs are being received by the driver, and turns off shortly (~1 sec.) after the clock stops. The MBC100 is a small, rugged package that is easy to mount horizontally or vertically by its integrated mounting bracket. The CURRENT SETTING potentiometer on the top of the driver should be set to the desired maximum motor current level before operating the driver. The input and output connections for the MBC100 are described in the following tables:

## CONNECTOR DB2 ( MOTOR )

The MBC100 has a green POWER indicator that is lit when the unit has a supply voltage in the proper range. The CLOCK indicator is lit whenever the unit is receiving clock signals. This indicator will turn off shortly (~1 sec.) after clocking stops.

Pin	Name	Description
1,6	A	Motor phase 1
3,8	A	Motor phase 3
2,7	B	Motor phase 2
4,9	B	Motor phase 4
5	NC	No connection

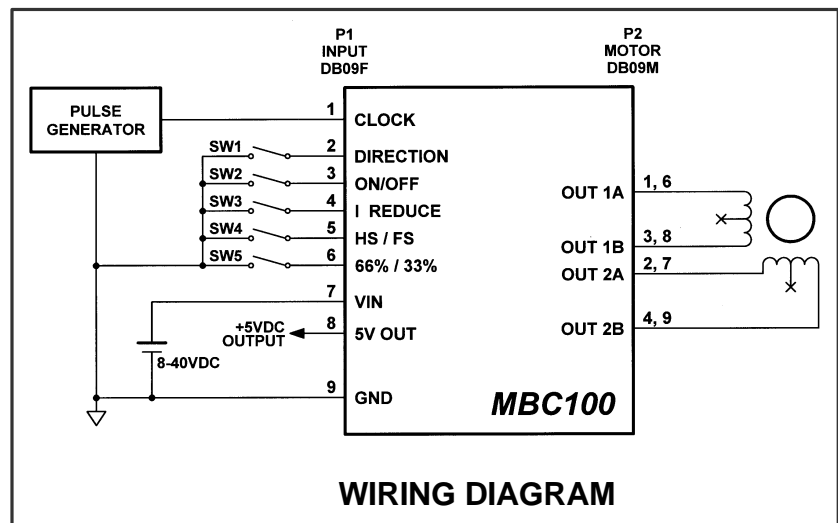

910 E. Orangefair Lane, Anaheim, CA 92801 •  
 (714) 992-8990 • Fax: (714) 992-0471  
 website: [www.anaheimautomation.com](http://www.anaheimautomation.com)

## CONNECTOR DB1 (INPUT)

Pin	Name	Description
1	CLOCK	The CLOCK input is the stepping clock for the driver. When the clock input transitions from high to low, the motor takes one step.
2	DIRECTION	The DIRECTION input controls the direction in which the motor steps. If the DIRECTION input is high the motor will step in the clockwise (CW) direction. If the DIRECTION input is low the motor will step in the counterclockwise (CCW) direction. The directions are defined looking in to the shaft of the motor. <i>Note that the order of connection of the motor leads to the driver outputs affects the direction in which the motor turns.</i>
3	ON/OFF	The ON/OFF input controls the motor. If the ON/OFF input is high, the motor will step with the clock and will have a holding current at standstill. If the ON/OFF input is low the motor will be turned off with no holding current and clock signals will be ignored. When the ON/ OFF input becomes high again, the motor will hold at the step it was at when the ON/OFF input went low.
4	CURRENT REDUCE	When the motor has been at standstill for two seconds, the driver will enter a reduced current mode if the CURRENT_REDUCE input is high. The current level in the motor will automatically adjust to a level determined by the 66%/33% input. If the CURRENT_REDUCE input is low, automatic current reduction will be disabled. <i>Note that if automatic current reduction is disabled and the motor is held at standstill for long periods of time, the motor or driver may experience heating problems.</i>
5	HS/FS	The HS/FS input controls the step mode of the driver. If the HS/FS input is high, the driver will be in half-step mode. If the HS/FS input is low, the driver will be in full-step mode.
6	66% / 33%	The 66% / 33% input controls the level of current in the motor in the automatic current reduction mode. If the 66% / 33% input is high, the motor current will drop to 66% of the CURRENT SETTING current. If the input is low, the motor current will drop to 33% of the CURRENT SETTING current. <i>Note that with some motors, the 33% level may cause audible noise while at standstill.</i>
7	V <sub>IN</sub>	V <sub>IN</sub> is the power supply for the driver. V <sub>IN</sub> should be in the range of 8V - 40V DC. NOTE: <i>Using 40Vdc will give the best motor performance</i>
8	5V <sub>OUT</sub>	The 5V <sub>OUT</sub> pin provides a regulated 5V DC output from the driver. This output is intended for limited-power applications (<100mA current)
9	GROUND	This pin is the ground reference for V <sub>IN</sub> and 5V <sub>OUT</sub> .

The logic inputs to the MBC100 are of the sourcing type, meaning that an input left open will automatically be pulled up to a high level. To drive input low, tie it to ground directly or use a saturated transistor.

## SPECIFICATIONS

Parameter	MIN.	MAX.	Unit
Continuous output current	200	1000	mA
Peak output current		1	A
33% standstill output current	66	248	mA
66% standstill output current	132	495	mA
Supply voltage	8	40	V DC
Clock frequency	0	10k	Hz
Chopping frequency		22k	Hz
Operating temperature	0	70	°C
5V <sub>OUT</sub> current		100	mA

