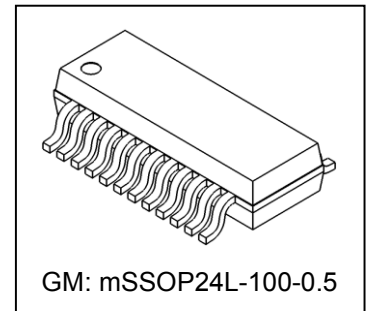

**16-Channel Constant Current LED Sink Driver****Features**

- 16 constant-current output channels
- Constant output current invariant to load voltage change:
Constant output current range:
3-25mA@ $V_{DD}=5V$;
3-10mA@ $V_{DD}=3.3V$
- Excellent output current accuracy
between channels: $\pm 1.5\%$ (typ.) and $\pm 2\%$ (max.)
between ICs: $\pm 1.5\%$ (typ.) and $\pm 3\%$ (max.)
- Output current adjusted through an external resistor
- Fast response of output current, \overline{OE} (min.): 70ns with good uniformity
between output channels
- Staggered delay of output
- 25MHz clock frequency
- Schmitt trigger input
- 3.3V/ 5V supply voltage

**Product Description**

With PrecisionDrive™ technology, MBI5120 is designed for LED displays which require to operate at low current and to match the luminous intensity of each channel. It provides supply voltage and accepts CMOS logic input at 3.3V and 5.0V to meet the trend of low power consumption. MBI5120 contains a serial buffer and data latches which convert serial input data into parallel output format. At MBI5120 output stage, sixteen regulated current ports are designed to provide uniform and constant current sinks for driving LEDs within a large range of V_F variations.

MBI5120 provides users with great flexibility and device performance while using MBI5120 in their system design for LED display applications, e.g. LED panels. It accepts an input voltage range from 3V to 5.5V and maintains a constant current up from 1mA to 25mA determined by an external resistor, R_{ext} , which gives users flexibility in controlling the light intensity of LEDs. MBI5120 guarantees to endure maximum 17V at the output port. The high clock frequency, 25 MHz, also satisfies the system requirements of high volume data transmission.

Block Diagram

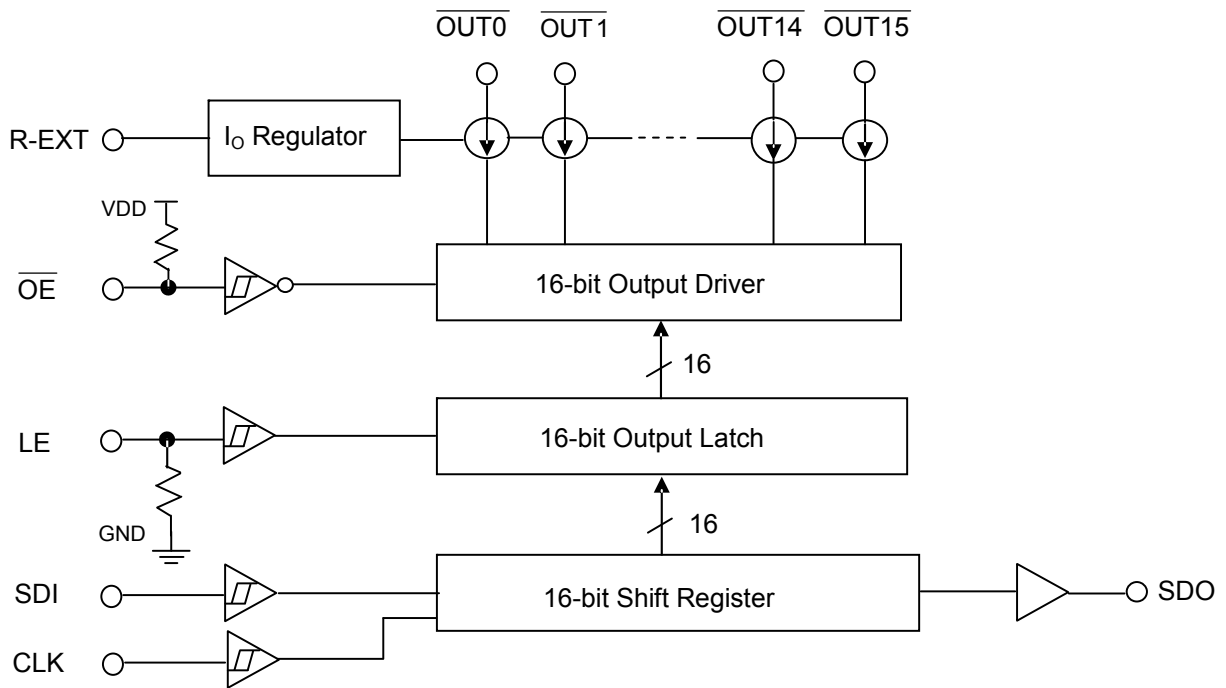

Pin Configuration

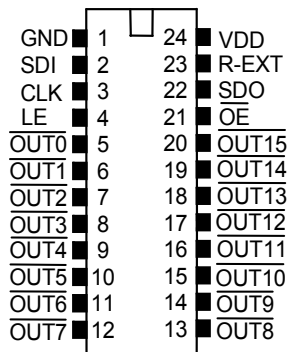

MBI5120GM

Terminal Description

Pin Name	Function
GND	Ground terminal for control logic and current sink
SDI	Serial-data input to the shift register
CLK	Clock input terminal for data shift on rising edge
LE	Data strobe input terminal Serial data is transferred to the output latch when LE is high. The data is latched when LE goes low.
OUT0 ~ OUT15	Constant current output terminals
OE	Output enable terminal When OE (active) low $\overline{OUT0} \sim \overline{OUT15}$ are enabled. When OE high $\overline{OUT0} \sim \overline{OUT15}$ are turned OFF (blanked).
SDO	Serial-data output to the following SDI of next driver IC
R-EXT	Input terminal used to connect an external resistor for setting up output current for all output channels
VDD	3.3V/5V supply voltage terminal

Equivalent Circuits of Inputs and Outputs

$\overline{\text{OE}}$ terminal

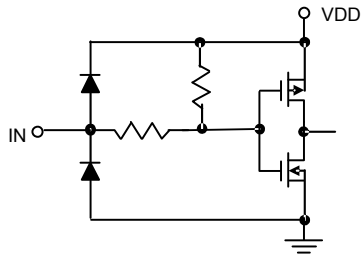

LE terminal

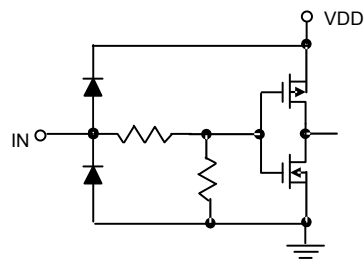

CLK, SDI terminal

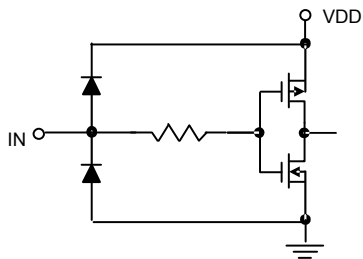

SDO terminal

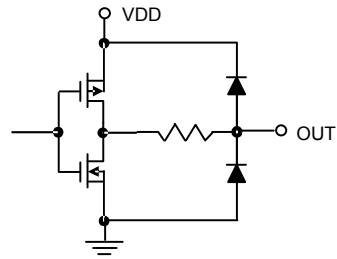

Timing Diagram

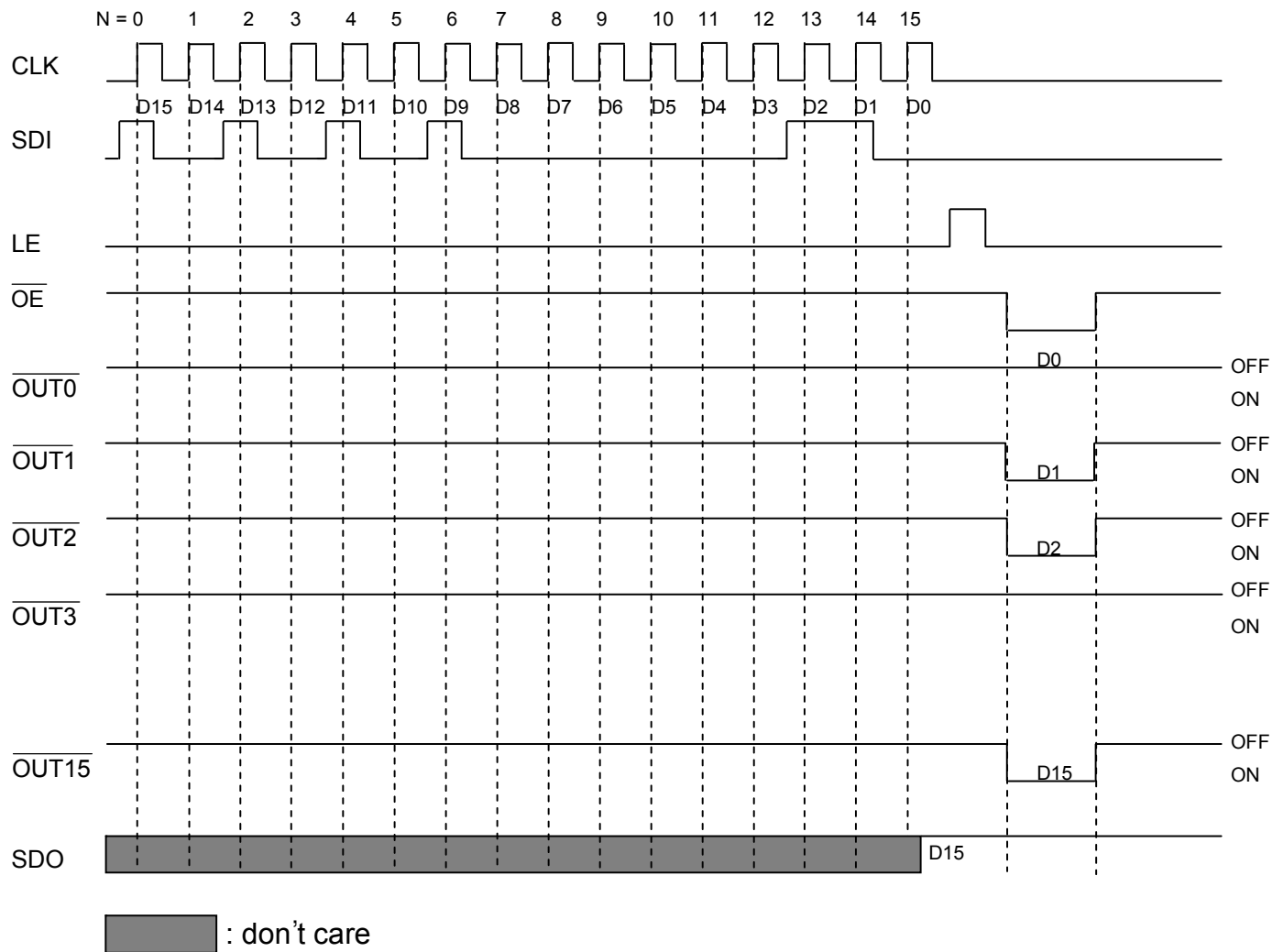

Truth Table

CLK	LE	\overline{OE}	SDI	$\overline{OUT0} \dots \overline{OUT7} \dots \overline{OUT15}$	SDO
	H	L	D_n	$\overline{D_n} \dots \overline{D_{n-7}} \dots \overline{D_{n-15}}$	D_{n-15}
	L	L	D_{n+1}	No Change	D_{n-14}
	H	L	D_{n+2}	$\overline{D_{n+2}} \dots \overline{D_{n-5}} \dots \overline{D_{n-13}}$	D_{n-13}
	X	L	D_{n+3}	$\overline{D_{n+2}} \dots \overline{D_{n-5}} \dots \overline{D_{n-13}}$	D_{n-13}
	X	H	D_{n+3}	Off	D_{n-13}

Maximum Ratings

Characteristic		Symbol	Rating	Unit
Supply Voltage		V_{DD}	0~7.0	V
Input Voltage (SDI, CLK, LE, GCLK)		V_{IN}	-0.4~ $V_{DD}+0.4$	V
Output Current		I_{OUT}	+30	mA
Sustaining Voltage at OUT Port		V_{DS}	-0.5~+17.0	V
GND Terminal Current		I_{GND}	480	mA
Power Dissipation (On PCB, Ta= 25°C)*	GM-type	P_D	1.33	W
Thermal Resistance(On PCB, Ta= 25°C)*	GM-type	$R_{th(j-a)}$	93.50	°C/W
Operating Junction Temperature		$T_{j,max}$	150**	°C
Operating Ambient Temperature		T_{opr}	-40~+85	°C
Storage Temperature		T_{stg}	-55 ~ +150	°C
ESD Rating	HBM (MIL-STD-883G Method 3015.8, Human Body Mode)	-	Class 3A (6KV)	-
	MM (ANSI/ ESD S5.2-2009, Machine Mode)	-	Class M4 (500V)	-

* The PCB size is 76.2mm*114.3mm in simulation. Please refer to JEDEC JESD51.

** Operation at the maximum rating for extended periods may reduce the device reliability; therefore, the suggested junction temperature of the device is under 125°C.

Note: The performance of thermal dissipation is strongly related to the size of thermal pad, thickness and layer numbers of the PCB. The empirical thermal resistance may be different from simulative value. Users should plan for expected thermal dissipation performance by selecting package and arranging layout of the PCB to maximize the capability.

Electrical Characteristics (V_{DD} = 5.0V)

Characteristics		Symbol	Condition		Min.	Typ.	Max.	Unit
Supply Voltage		V _{DD}	-		4.5	5.0	5.5	V
Output Voltage		V _{DS}	$\overline{\text{OUT0}} \sim \overline{\text{OUT15}}$		-	-	17	V
Output Current		I _{OUT}	Refer to „Test Circuit for Electrical Characteristics”		3.0	-	25	mA
		I _{OH}	SDO		-	-1.0	-	mA
		I _{OL}	SDO		-	1.0	-	mA
Input Voltage	„H” level	V _{IH}	T _a =-40~85°C		0.7 x V _{DD}	-	V _{DD}	V
	„L” level	V _{IL}	T _a =-40~85°C		GND	-	0.3 x V _{DD}	V
Output Leakage Current		I _{OH}	V _{DS} =17.0V		-	-	0.5	μA
Output Voltage	SDO	V _{OL}	I _{OL} =+1.0mA		-	-	0.4	V
		V _{OH}	I _{OH} =-1.0mA		V _{DD} -0.4	-	-	V
Output Current 1		I _{OUT1}	V _{DS} =1.0V	R _{ext} =1240 Ω	-	15	-	mA
Current Skew		dI _{OUT1}	I _{OL} =15mA V _{DS} =1.0V	R _{ext} =1240 Ω	-	±1.5	±2.5	%
Current Skew		dI _{OUT2}	I _{OL} =15mA V _{DS} =1.0V	R _{ext} =1240 Ω	-	±1.5	±3.0	%
Output Current vs. Output Voltage Regulation		%/dV _{DS}	V _{DS} within 1.0V and 3.0V		-	±0.1	±0.3	%/V
Output Current vs. Supply Voltage Regulation		%/dV _{DD}	V _{DD} within 4.5V and 5.5V		-	-	±1.0	%/V
Pull-up Resistor		R _{IN(up)}	$\overline{\text{OE}}$		200	460	700	KΩ
Pull-down Resistor		R _{IN(down)}	LE		200	460	700	KΩ
Supply Current	“OFF”	I _{DD(off) 1}	R _{ext} = Open , $\overline{\text{OUT0}} \sim \overline{\text{OUT15}}$ =Off		-	2.7	3.7	mA
		I _{DD(off) 2}	R _{ext} =1240Ω, $\overline{\text{OUT0}} \sim \overline{\text{OUT15}}$ =Off		-	9.7	10.7	
	“ON”	I _{DD(on) 1}	R _{ext} =1240Ω, $\overline{\text{OUT0}} \sim \overline{\text{OUT15}}$ =On		-	8.5	9.5	

Electrical Characteristics (V_{DD} = 3.3V)

Characteristics		Symbol	Condition	Min.	Typ.	Max.	Unit
Supply Voltage		V _{DD}	-	3.0	3.3	3.6	V
Output Voltage		V _{DS}	$\overline{\text{OUT0}} \sim \overline{\text{OUT15}}$	-	-	17	V
Output Current		I _{OUT}	Refer to „Test Circuit for Electrical Characteristics”	3.0	-	15	mA
		I _{OH}	SDO	-	-1.0	-	mA
		I _{OL}	SDO	-	1.0	-	mA
Input Voltage	„H” level	V _{IH}	T _a =-40~85°C	0.7 x V _{DD}	-	V _{DD}	V
	„L” level	V _{IL}	T _a =-40~85°C	GND	-	0.3 x V _{DD}	V
Output Leakage Current		I _{OH}	V _{DS} =17.0V	-	-	0.5	μA
Output Voltage	SDO	V _{OL}	I _{OL} =+1.0mA	-	-	0.4	V
		V _{OH}	I _{OH} =-1.0mA	V _{DD} -0.4	-	-	V
Output Current 1		I _{OUT1}	V _{DS} =1.0V R _{ext} =1240 Ω	-	15	-	mA
Current Skew		dI _{OUT1}	I _{OL} =15mA V _{DS} =1.0V R _{ext} =1240 Ω	-	±1.5	±2.5	%
Current Skew		dI _{OUT2}	I _{OL} =15mA V _{DS} =1.0V R _{ext} =1240 Ω	-	±1.5	±3.0	%
Output Current vs. Output Voltage Regulation		%/dV _{DS}	V _{DS} within 1.0V and 3.0V	-	±0.1	±0.3	%/V
Output Current vs. Supply Voltage Regulation		%/dV _{DD}	V _{DD} within 3.0V and 3.6V	-	-	±1.0	%/V
Pull-up Resistor		R _{IN(up)}	$\overline{\text{OE}}$	200	460	700	KΩ
Pull-down Resistor		R _{IN(down)}	LE	200	460	700	KΩ
Supply Current	“OFF”	I _{DD(off) 1}	R _{ext} =Open, $\overline{\text{OUT0}} \sim \overline{\text{OUT15}}$ =Off	-	2.5	3.5	mA
		I _{DD(off) 2}	R _{ext} =1240Ω, $\overline{\text{OUT0}} \sim \overline{\text{OUT15}}$ =Off	-	9.2	10.2	
	“ON”	I _{DD(on) 1}	R _{ext} =1240Ω, $\overline{\text{OUT0}} \sim \overline{\text{OUT15}}$ =On	-	8.8	9.8	

Test Circuit for Electrical Characteristics

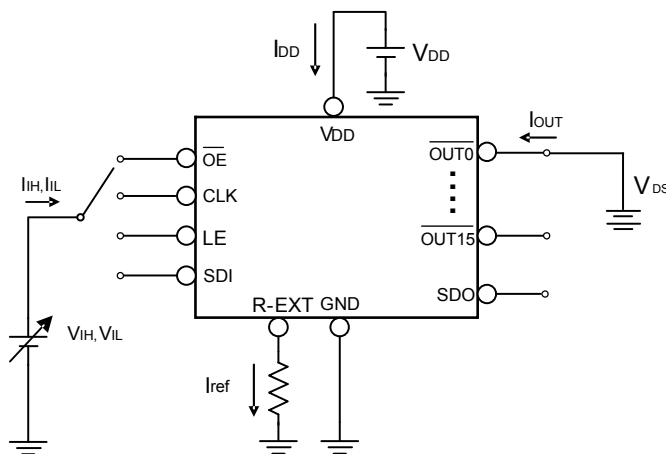

Switching Characteristics (V_{DD} = 5.0V)

Characteristics		Symbol	Condition	Min.	Typ.	Max.	Unit
Propagation Delay Time („L” to „H”)	CLK- $\overline{\text{OUT}}_{2n}$ *	t_{pLH1}	V _{DD} =5.0V V _{DS} =1.0V V _{IH} =V _{DD} V _{IL} =GND R _{ext} =1240Ω V _L =4.0V R _L =200Ω C _L =10pF	-	37	52	ns
	CLK- $\overline{\text{OUT}}_{2n+1}$ *			-	35	50	ns
	LE- $\overline{\text{OUT}}_{2n}$	t_{pLH2}		-	37	52	ns
	LE- $\overline{\text{OUT}}_{2n+1}$			-	35	50	ns
	$\overline{\text{OE}}$ - $\overline{\text{OUT}}_{2n}$	t_{pLH3}		-	37	52	ns
	$\overline{\text{OE}}$ - $\overline{\text{OUT}}_{2n+1}$			-	35	50	ns
	CLK-SDO	t_{pLH}		-	25	35	ns
Propagation Delay Time („H” to „L”)	CLK- $\overline{\text{OUT}}_{2n}$	t_{pHL1}		-	27	37	ns
	CLK- $\overline{\text{OUT}}_{2n+1}$			-	25	35	ns
	LE- $\overline{\text{OUT}}_{2n}$	t_{pHL2}		-	22	32	ns
	LE- $\overline{\text{OUT}}_{2n+1}$			-	20	30	ns
	$\overline{\text{OE}}$ - $\overline{\text{OUT}}_{2n}$	t_{pHL3}		-	22	32	ns
	$\overline{\text{OE}}$ - $\overline{\text{OUT}}_{2n+1}$			-	20	30	ns
	CLK-SDO	t_{pHL}		-	25	35	ns
Pulse Width	CLK	$t_{w(\text{CLK})}$	20	-	-	ns	
	LE	$t_{w(L)}$	20	-	-	ns	
	$\overline{\text{OE}}$ **	$t_{w(\text{OE})}$	50	65	-	ns	
Hold Time for LE		$t_{h(L)}$	30	-	-	ns	
Setup Time for LE		$t_{su(L)}$	5	-	-	ns	
Hold Time for SDI		$t_{h(D)}$	5	-	-	ns	
Setup Time for SDI		$t_{su(D)}$	3	-	-	ns	
Maximum CLK Rise Time		t_r	-	-	500	ns	
Maximum CLK Fall Time		t_f	-	-	500	ns	
SDO Rise Time		$t_{r,\text{SDO}}$	-	10	-	ns	
SDO Fall Time		$T_{f,\text{SDO}}$	-	10	-	ns	
Output Rise Time of Output Ports		t_{or}	-	35	45	ns	
Output Fall Time of Output Ports		t_{of}	-	40	50	ns	

*The staggered delay between odd channels, $\overline{\text{OUT}}_{2n+1}$ (e.g. OUT1, OUT3, OUT5, etc.) and even channels $\overline{\text{OUT}}_{2n}$ (e.g. OUT2, OUT4, OUT6, etc.) is 2ns. MBI5120 has a built-in staggered circuit to perform delay mechanism, by which the even and odd output ports will be turned on at a different time so that the instant current from the power line will be lowered.

** With uniform output current.

Switching Characteristics (V_{DD} = 3.3V)

Characteristics		Symbol	Condition	Min.	Typ.	Max.	Unit
Propagation Delay Time („L” to „H”)	CLK-OUT 2n *	t _{pLH1}	V _{DD} =3.3V V _{DS} =1.0V V _{IH} =V _{DD} V _{IL} =GND R _{ext} =1240Ω V _L =4.0V R _L =200Ω C _L =10 pF	-	52	72	ns
	CLK-OUT 2n + 1*			-	50	70	ns
	LE-OUT 2n	t _{pLH2}		-	52	72	ns
	LE-OUT 2n + 1			-	50	70	ns
	OE - OUT 2n	t _{pLH3}		-	52	72	ns
	OE - OUT 2n + 1			-	50	70	ns
	CLK-SDO	t _{pLH}		-	35	45	ns
Propagation Delay Time („H” to „L”)	CLK-OUT 2n	t _{pHL1}		-	27	37	ns
	CLK-OUT 2n + 1			-	25	35	ns
	LE-OUT 2n	t _{pHL2}		-	27	37	ns
	LE-OUT 2n + 1			-	25	35	ns
	OE - OUT 2n	t _{pHL3}		-	27	37	ns
	OE - OUT 2n + 1			-	25	35	ns
	CLK-SDO	t _{pHL}		-	35	45	ns
Pulse Width	CLK	t _{w(CLK)}	20	-	-	ns	
	LE	t _{w(L)}	20	-	-	ns	
	OE **	t _{w(OE)}	60	75	-	ns	
Hold Time for LE		t _{h(L)}	30	-	-	ns	
Setup Time for LE		t _{su(L)}	5	-	-	ns	
Hold Time for SDI		t _{h(D)}	5	-	-	ns	
Setup Time for SDI		t _{su(D)}	3	-	-	ns	
Maximum CLK Rise Time		t _r	-	-	500	ns	
Maximum CLK Fall Time		t _f	-	-	500	ns	
SDO Rise Time		t _{r,SDO}	-	10	-	ns	
SDO Fall Time		T _{f,SDO}	-	10	-	ns	
Output Rise Time of Output Ports		t _{or}	-	60	75	ns	
Output Fall Time of Output Ports		t _{of}	-	45	60	ns	

*The staggered delay between odd channels, $\overline{\text{OUT}2n+1}$ (e.g. OUT1, OUT3, OUT5, etc.) and even channels $\overline{\text{OUT}2n}$ (e.g. OUT2, OUT4, OUT6, etc.) is 2ns. MBI5020 has a built-in staggered circuit to perform delay mechanism, by which the even and odd output ports will be turned on at a different time so that the instant current from the power line will be lowered.

** With uniform output current.

Test Circuit for Switching Characteristics

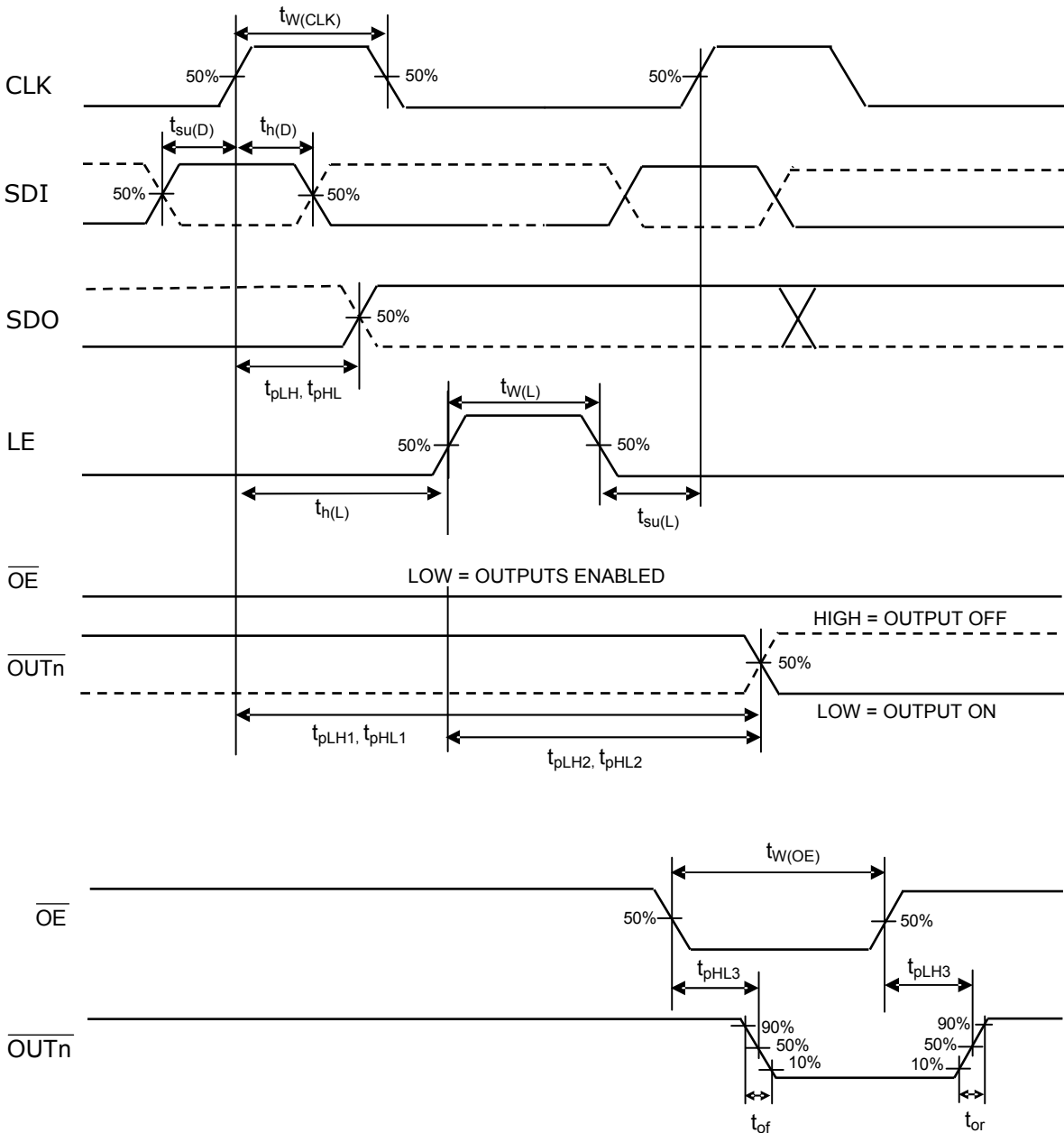
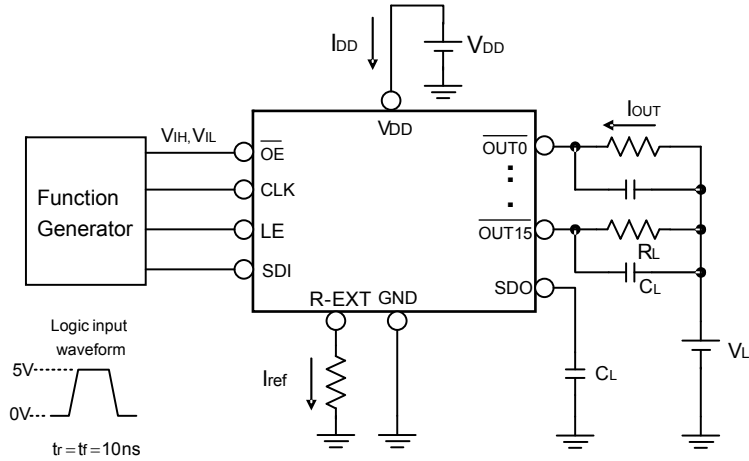

Application Information

Constant Current

To design LED displays, MBI5120 provides nearly no variations in current from channel to channel and from IC to IC. This can be achieved by:

- 1) The maximum current variation between channels is less than $\pm 2.5\%$, and that between ICs is less than $\pm 3\%$.
- 2) In addition, the current characteristic of output stage is flat and users can refer to the figure as shown below. The output current can be kept constant regardless of the variations of LED forward voltages (V_F). This performs as a perfection of load regulation.

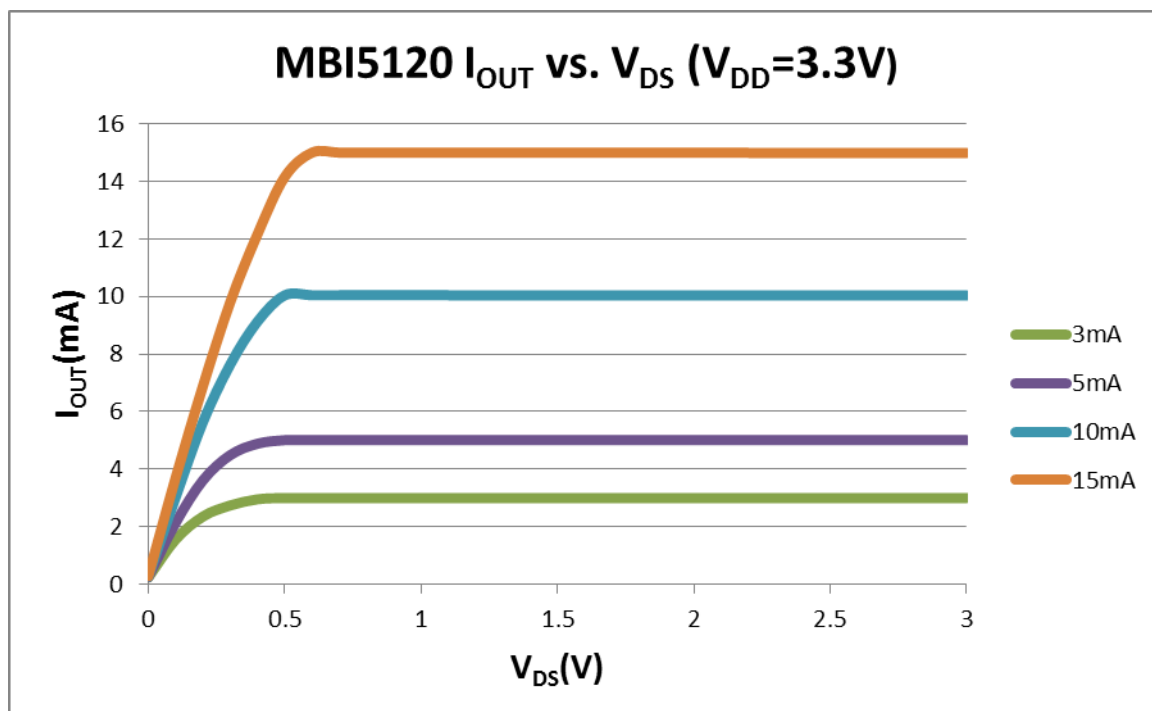
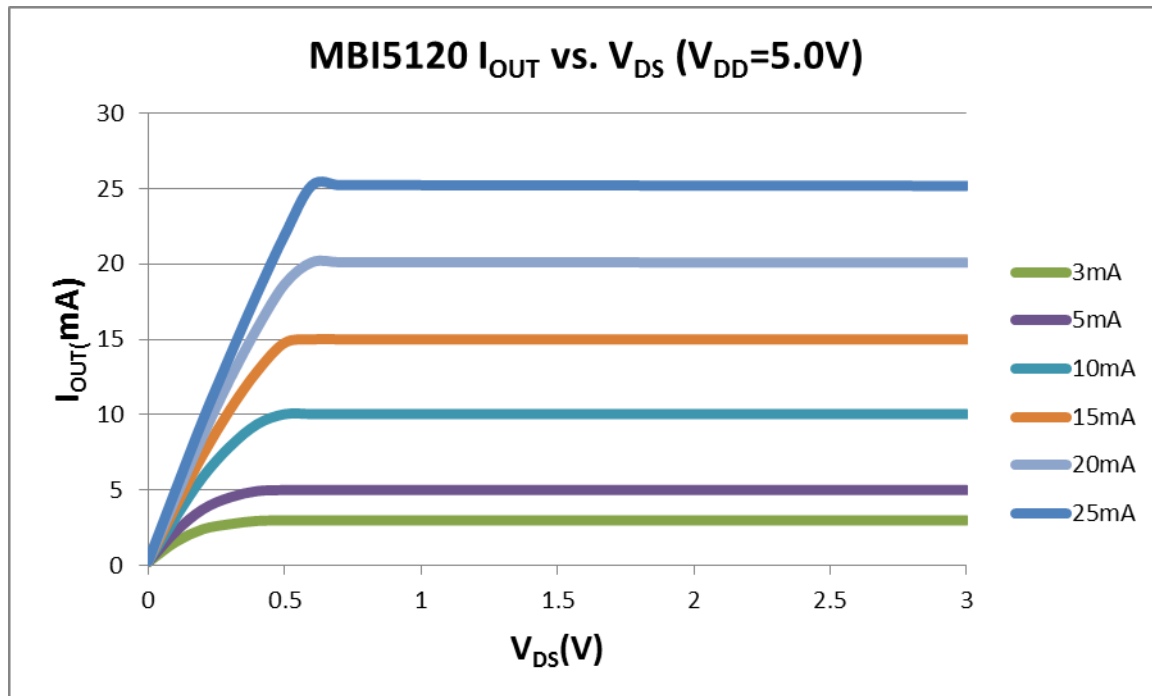

Adjusting Output Current

The output current of each channel (I_{OUT}) is set by an external resistor, R_{EXT} . The relationship between I_{OUT} and R_{EXT} is shown in the following figure.

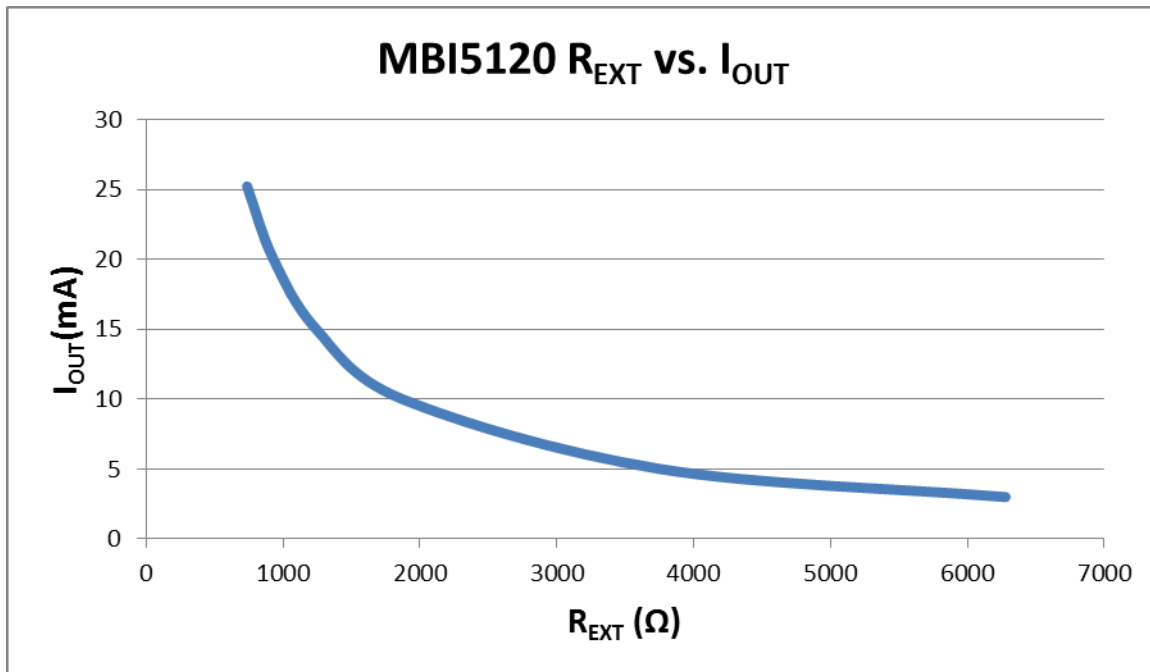

Also, the output current can be calculated from the equation:

$$V_{R-EXT}=1.24V; I_{OUT}=V_{R-EXT} \cdot (1/R_{EXT}) \times 15; R_{EXT}=(V_{R-EXT}/I_{OUT}) \times 15$$

where R_{EXT} is the resistance of the external resistor connected to R-EXT terminal and V_{R-EXT} is the voltage of R-EXT terminal. The magnitude of current (as a function of R_{EXT}) is around 25mA at 744 Ω and 10mA at 1860 Ω .

Soldering Process of “Pb-free & Green” Package Plating*

Macroblock has defined "Pb-Free & Green" to mean semiconductor products that are compatible with the current RoHS requirements and selected 100% pure tin (Sn) to provide forward and backward compatibility with both the current industry-standard SnPb-based soldering processes and higher-temperature Pb-free processes. Pure tin is widely accepted by customers and suppliers of electronic devices in Europe, Asia and the US as the lead-free surface finish of choice to replace tin-lead. Also, it adopts tin/lead (SnPb) solder paste, and please refer to the JEDEC J-STD-020C for the temperature of solder bath. However, in the whole Pb-free soldering processes and materials, 100% pure tin (Sn) will all require from 245°C to 260°C for proper soldering on boards, referring to JEDEC J-STD-020C as shown below.

For managing MSL3 Package, it should refer to JEDEC J-STD-0 20C about floor life management & refer to JEDEC J-STD-033C about re-bake condition while IC's floor life exceeds MSL3 limitation.

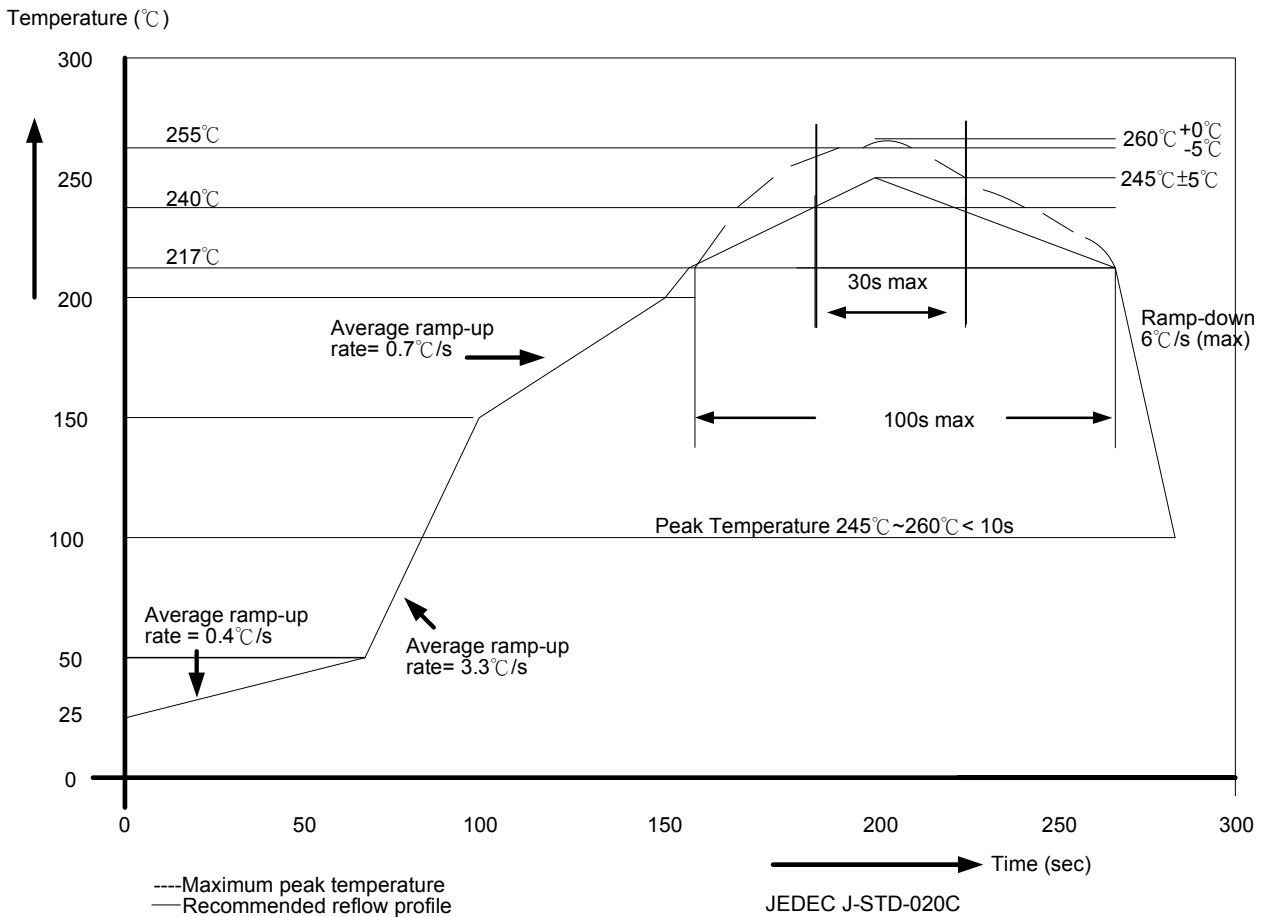

Package Thickness	Volume mm ³ <350	Volume mm ³ 350-2000	Volume mm ³ ≥2000
<1.6mm	260 +0 °C	260 +0 °C	260 +0 °C
1.6mm – 2.5mm	260 +0 °C	250 +0 °C	245 +0 °C
≥2.5mm	250 +0 °C	245 +0 °C	245 +0 °C

* For details, please refer to Macroblock’s “Policy on Pb-free & Green Package”.

Package Power Dissipation (P_D)

The maximum allowable package power dissipation is determined as $P_D(max)=(T_j-T_a)/R_{th(j-a)}$. When 16 output channels are turned on simultaneously, the actual package power dissipation is

$P_D(act)=(I_{DD} \times V_{DD})+(I_{OUT} \times Duty \times V_{DS} \times 16)$. Therefore, to keep $P_D(act) \leq P_D(max)$, the allowable maximum output current as a function of duty cycle is:

$I_{OUT} = \{[(T_j - T_a) / R_{th(j-a)}] - (I_{DD} \times V_{DD})\} / V_{DS} / Duty / 16$, where $T_j = 150^\circ C$.

Condition: $I_{OUT} = 25mA$, 16 output channels active		
Package	$R_{th(j-a)} (^{\circ}C/W)$	$P_D (W)$
GM	93.5	1.33

The maximum power dissipation, $P_D(max)=(T_j-T_a)/R_{th(j-a)}$, decreases as the ambient temperature increases.

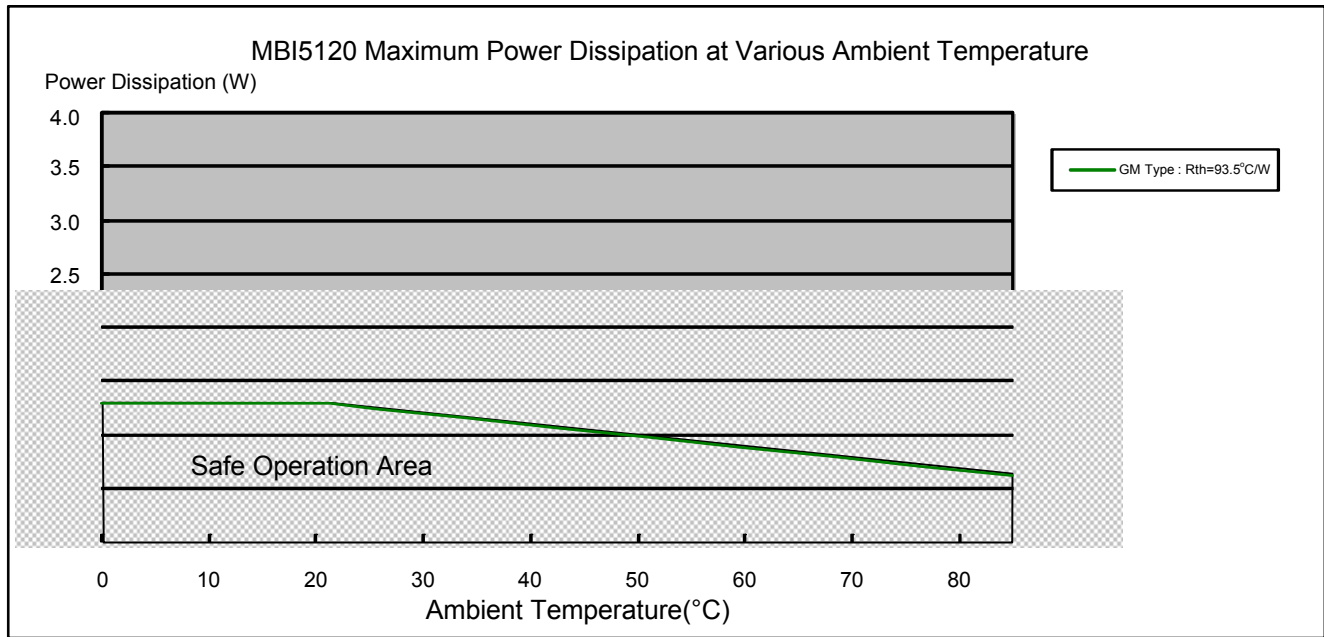

Load Supply Voltage (V_{LED})

MBI5020 are designed to operate with V_{DS} ranging from 0.4V to 0.8V (depending on $I_{OUT}=3\sim 25mA$) considering the package power dissipating limits. V_{DS} may be higher enough to make $P_{D(act)} > P_{D(max)}$ when $V_{LED}=5V$ and $V_{DS}=V_{LED}-V_F$, in which V_{LED} is the load supply voltage. In this case, it is recommended to use the lowest possible supply voltage or to set an external voltage reducer, V_{DROP} .

A voltage reducer lets $V_{DS}=(V_{LED}-V_F)-V_{DROP}$.

Resistors or Zener diode can be used in the applications as shown in the following figures.

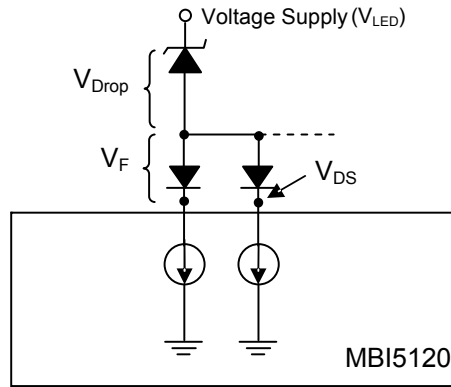
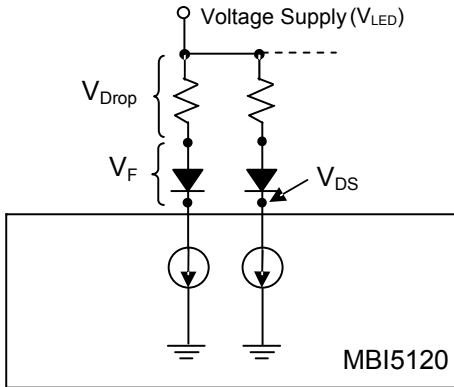

Package Outline

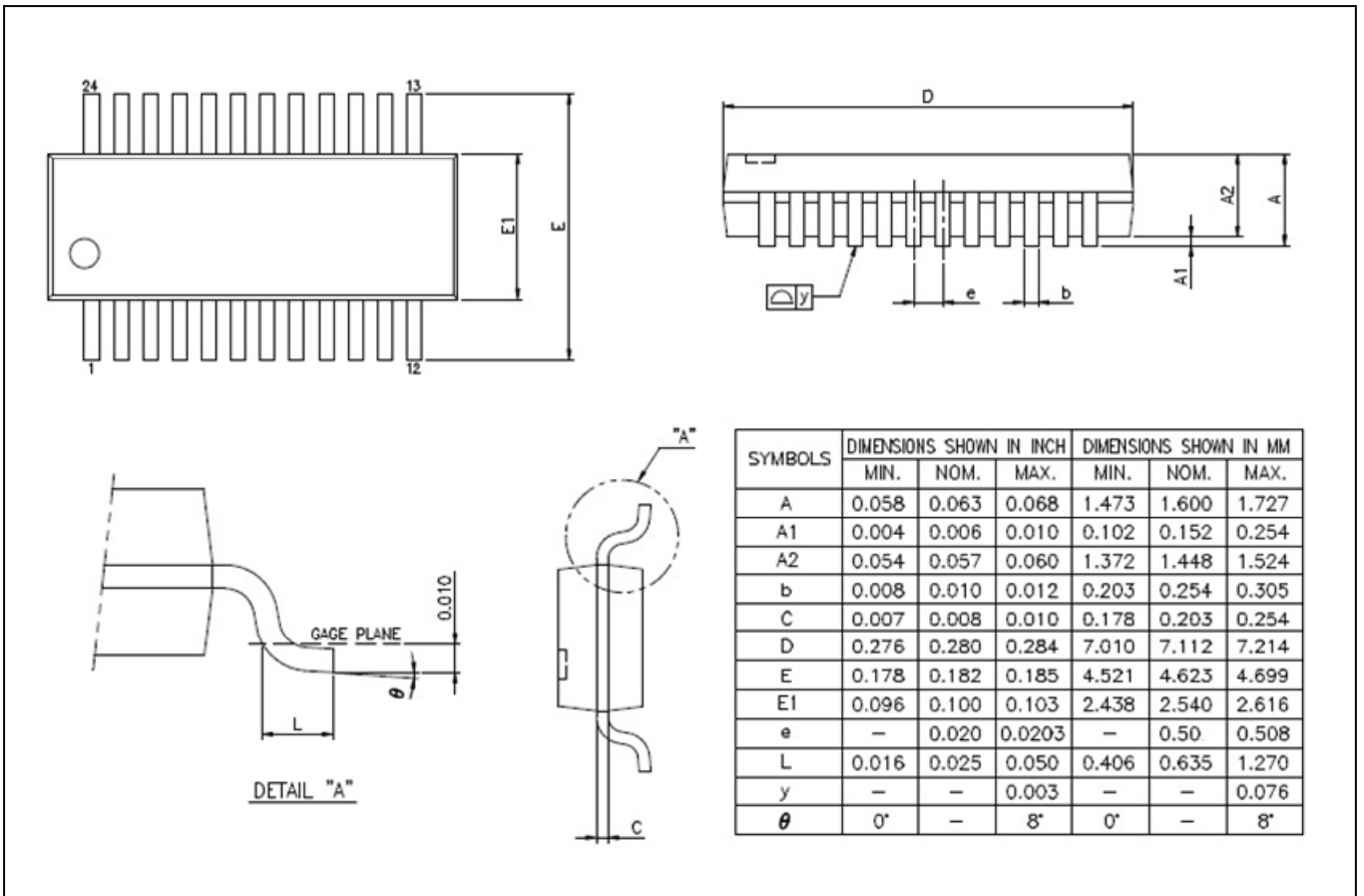

MBI5120GM Outline Drawing

Product Top-mark Information

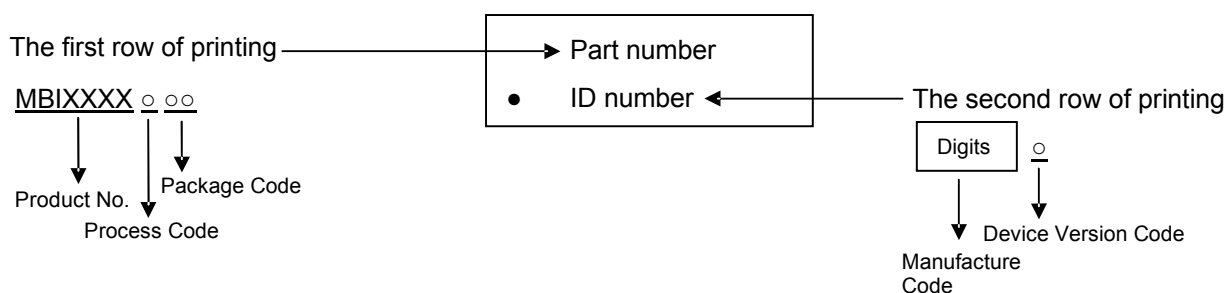

Product Revision History

Datasheet Version	Device Version Code
V1.00	A
V1.01	A
V1.02	A
V2.00	B
V2.01	B

Product Ordering Information

Part Number *	RoHS Package Type	Weight (g)
MBI5120GM-B	mSSOP24L-100-0.5	0.079

*Please place your order with the „Part Number” information on your purchase order (PO).

Disclaimer

Macroblock reserves the right to make changes, corrections, modifications, and improvements to their products and documents or discontinue any product or service without notice. Customers are advised to consult their sales representative for the latest product information before ordering. All products are sold subject to the terms and conditions supplied at the time of order acknowledgement, including those pertaining to warranty, patent infringement, and limitation of liability.

Macroblock's products are not designed to be used as components in device intended to support or sustain life or in military applications. Use of Macroblock's products in components intended for surgical implant into the body, or other applications in which failure of Macroblock's products could create a situation where personal death or injury may occur, is not authorized without the express written approval of the Managing Director of Macroblock. Macroblock will not be held liable for any damages or claims resulting from the use of its products in medical and military applications.

All text, images, logos and information contained on this document is the intellectual property of Macroblock. Unauthorized reproduction, duplication, extraction, use or disclosure of the above mentioned intellectual property will be deemed as infringement.