



## TO-220-3L Plastic-Encapsulate Diodes

### MBR1030CT, 35CT, 40CT, 45CT, 50CT, 60CT

SCHOTTKY BARRIER RECTIFIER

#### FEATURES

- Schottky Barrier Chip
- Guard Ring Die Construction for Transient Protection
- Low Power Loss, High Efficiency
- High Surge Capability
- High Current Capability and Low Forward Voltage Drop
- For Use in Low Voltage, High Frequency Inverters, Free Wheeling, and Polarity Protection Applications

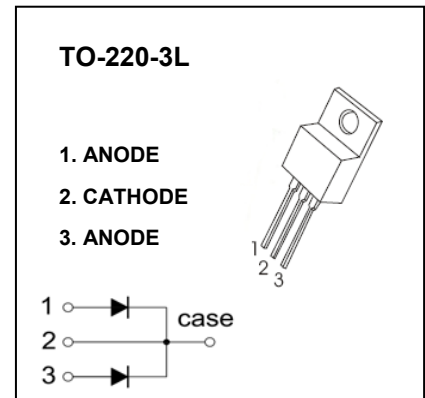

#### MAXIMUM RATINGS ( $T_a=25^\circ\text{C}$ unless otherwise noted )

Symbol	Parameter	Value						Unit
		MBR 1030CT	MBR 1035CT	MBR 1040CT	MBR 1045CT	MBR 1050CT	MBR 1060CT	
$V_{RRM}$	Peak repetitive reverse voltage	30	35	40	45	50	60	V
$V_{RWM}$	Working peak reverse voltage							
$V_R$	DC blocking voltage							
$V_{R(RMS)}$	RMS reverse voltage	21	24.5	28	31.5	35	42	V
$I_o$	Average rectified output current@ $T_c=105^\circ\text{C}$	10						A
$I_{FSM}$	Non-Repetitive peak forward surge current 8.3ms half sine wave	125						A
$P_D$	Power dissipation	2						W
$R_{\theta JA}$	Thermal resistance from junction to ambient	50						$^\circ\text{C}/\text{W}$
$T_j$	Junction temperature	125						$^\circ\text{C}$
$T_{stg}$	Storage temperature	-55~+150						$^\circ\text{C}$

**ELECTRICAL CHARACTERISTICS (T<sub>a</sub>=25°C unless otherwise specified)**

Parameter	Symbol	Device	Test conditions	Min	Typ	Max	Unit
Reverse voltage	V <sub>(BR)</sub>	MBR1030CT	I <sub>R</sub> =0.1mA	30			V
		MBR1035CT		35			
		MBR1040CT		40			
		MBR1045CT		45			
		MBR1050CT		50			
		MBR1060CT		60			
Reverse current	I <sub>R</sub>	MBR1030CT	V <sub>R</sub> =30V			0.1	mA
		MBR1035CT	V <sub>R</sub> =35V				
		MBR1040CT	V <sub>R</sub> =40V				
		MBR1045CT	V <sub>R</sub> =45V				
		MBR1050CT	V <sub>R</sub> =50V				
		MBR1060CT	V <sub>R</sub> =60V				
Forward voltage	V <sub>F(1)</sub>	MBR1030CT-1045CT	I <sub>F</sub> =5A			0.7	V
		MBR1050CT,1060CT				0.8	
	V <sub>F(2)*</sub>	MBR1030CT-1045CT	I <sub>F</sub> =10A			0.84	
		MBR1050CT,1060CT				0.95	

\*Pulse test

# Typical Characteristics

**Forward Characteristics**

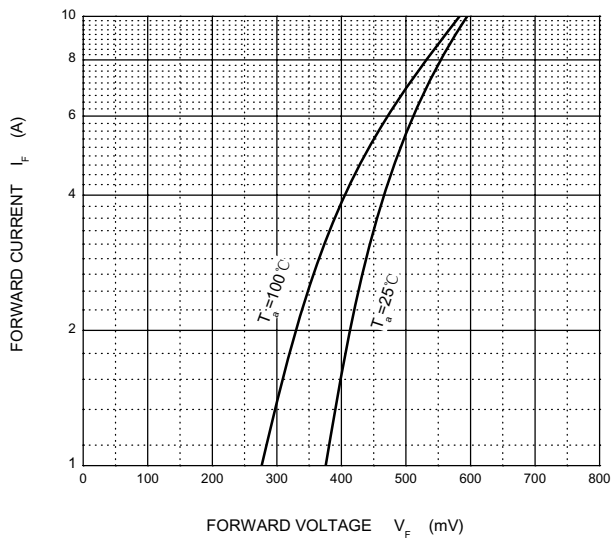

**Reverse Characteristics**

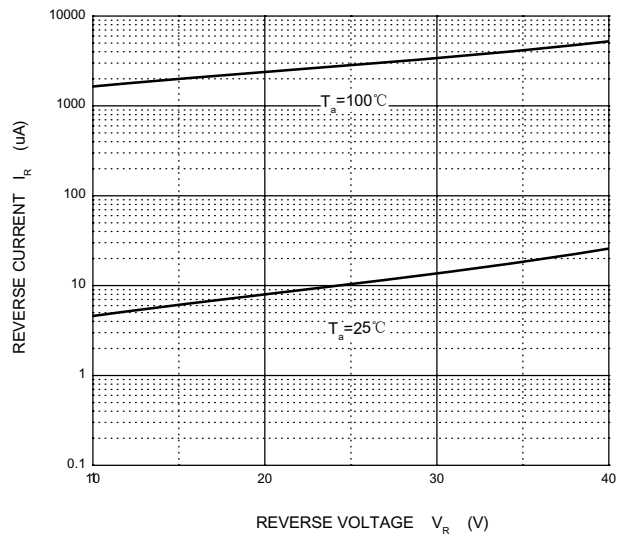

**Capacitance Characteristics**

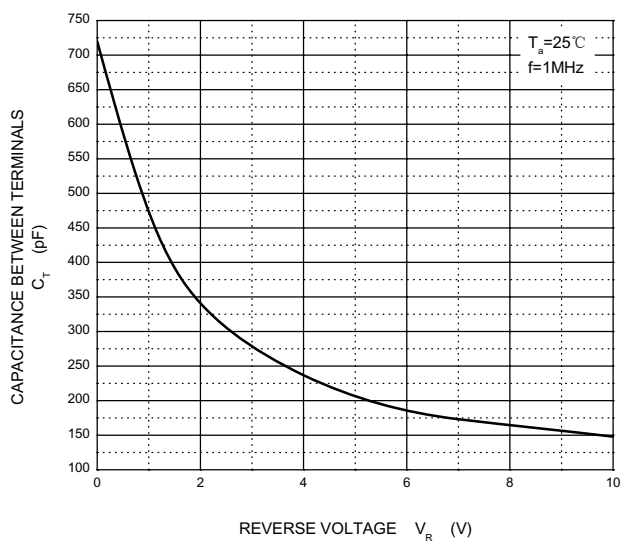

**Power Derating Curve**

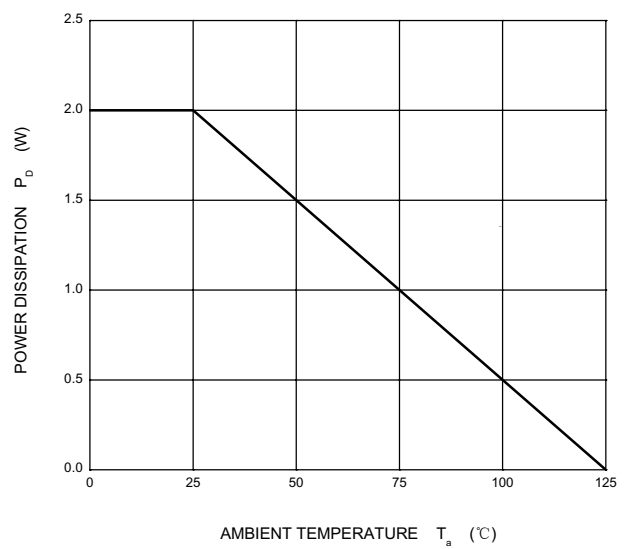

# TO-220-3L Package Outline Dimensions

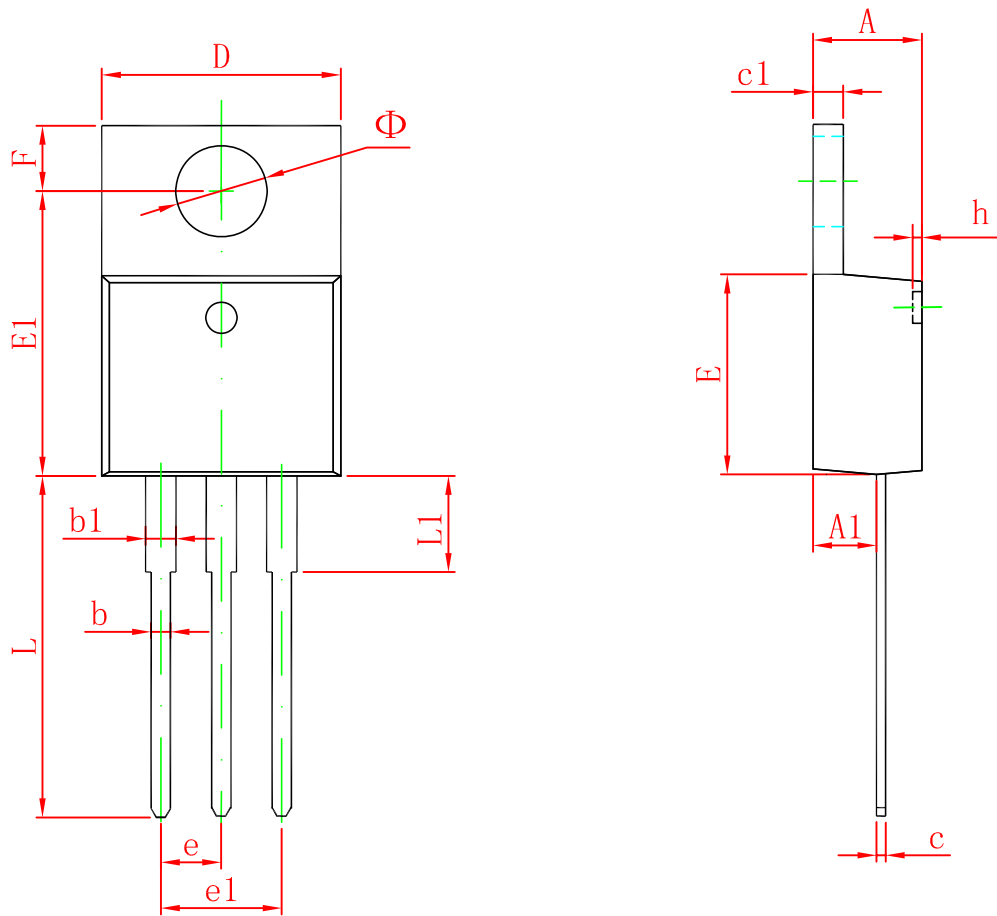

Symbol	Dimensions In Millimeters		Dimensions In Inches	
	Min	Max	Min	Max
A	4.470	4.670	0.176	0.184
A1	2.520	2.820	0.099	0.111
b	0.710	0.910	0.028	0.036
b1	1.170	1.370	0.046	0.054
c	0.310	0.530	0.012	0.021
c1	1.170	1.370	0.046	0.054
D	10.010	10.310	0.394	0.406
E	8.500	8.900	0.335	0.350
E1	12.060	12.460	0.475	0.491
e	2.540 TYP		0.100 TYP	
e1	4.980	5.180	0.196	0.204
F	2.590	2.890	0.102	0.114
h	0.000	0.300	0.000	0.012
L	13.400	13.800	0.528	0.543
L1	3.560	3.960	0.140	0.156
$\Phi$	3.735	3.935	0.147	0.155