

Schottky Barrier Rectifier

MBR1660CT

FEATURES

- Low Forward Voltage
- 150°C Operating Junction Temperature
- Guaranteed Reverse Avalanche
- Low Power Loss/High Efficiency
- High Surge Capacity
- Low Stored Charge Majority Carrier Conduction

MECHANICAL CHARACTERISTICS

- Case: Epoxy, Molded
- Finish: All External Surfaces Corrosion Resistant and Terminal Leads are Readily Solderable
- Lead Temperature for Soldering Purposes: 260°C Max. for 10 Seconds

ABSOLUTE MAXIMUM RATINGS(T<sub>a</sub>=25°C)

SYMBOL	PARAMETER	VALUE	UNIT
V <sub>RRM</sub>	Peak Repetitive Reverse Voltage	60	V
V <sub>RMS</sub>	RMS Voltage	42	
V <sub>R</sub>	DC Blocking Voltage	60	
I <sub>F(AV)</sub>	Average Rectified Forward Current (Rated V <sub>R</sub> ) T <sub>C</sub> = 100°C	16	A
I <sub>FSM</sub>	Nonrepetitive Peak Surge Current 8.3ms single half sine-wave superimposed on rated load conditions	125	A
I <sub>RRM</sub>	Peak Repetitive Reverse Current (2.0 μs, 1.0kHz)	0.5	A
T <sub>J</sub>	Junction Temperature	-55~150	°C
T <sub>stg</sub>	Storage Temperature Range	-55~175	°C

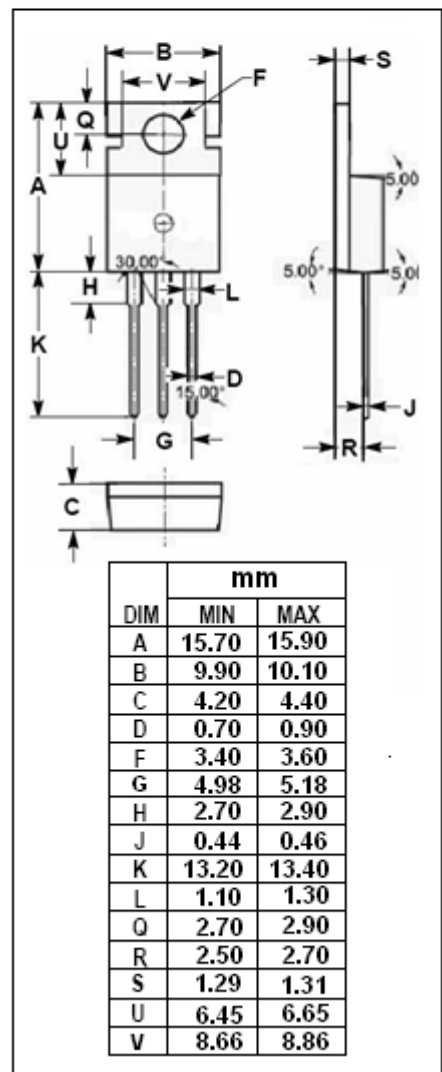
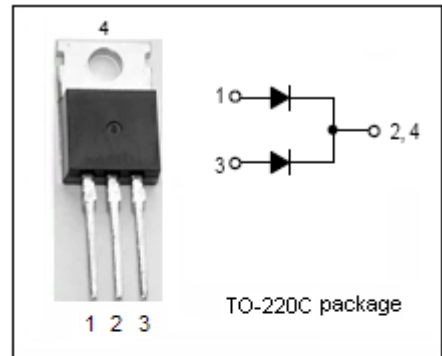

**Schottky Barrier Rectifier****MBR1660CT****THERMAL CHARACTERISTICS**

SYMBOL	PARAMETER	MAX	UNIT
$R_{th\ j-c}$	Thermal Resistance, Junction to Case	2.0	$^{\circ}C/W$

**ELECTRICAL CHARACTERISTICS**(Pulse Test: Pulse Width=300  $\mu$  s, Duty Cycle $\leq$ 2%)

SYMBOL	PARAMETER	CONDITIONS	MAX	UNIT
$V_F$	Maximum Instantaneous Forward Voltage	$I_F= 8A ; T_C= 25^{\circ}C$ $I_F= 8A ; T_C= 125^{\circ}C$	0.8 0.7	V
$I_R$	Maximum Instantaneous Reverse Current	Rated DC Voltage, $T_C= 25^{\circ}C$ Rated DC Voltage, $T_C= 100^{\circ}C$	0.1 50	mA