



MBR20150CT

主要参数 MAIN CHARACTERISTICS

$I_{F(AV)}$	20 (2×10) A
V_{RRM}	150 V
T_j	175 °C
$V_{F(max)}$	0.75V (@ $T_j=125^{\circ}C$)

用途

- 高频开关电源
- 低压续流电路和保护电路

产品特性

- 共阴结构
- 低功耗, 高效率
- 良好的高温特性
- 有过压保护环, 高可靠性
- 环保 (RoHS) 产品

APPLICATIONS

- High frequency switch power supply
- Free wheeling diodes, polarity protection applications

FEATURES

- Common cathode structure
- Low power loss, high efficiency
- High Operating Junction Temperature
- Guard ring for overvoltage protection, High reliability
- RoHS product

封装 Package

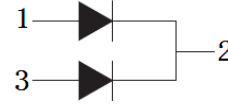

T0-220



T0-220F

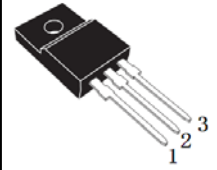

T0-220HF





绝对最大额定值 ABSOLUTE RATINGS (Tc=25°C)

项 目 Parameter		符 号 Symbol	数 值 Value	单 位 Unit
最大反向重复峰值电压 Repetitive peak reverse voltage		V _{RRM}	150	V
最大直流阻断电压 Maximum DC blocking voltage		V _{DC}	150	V
正向平均整流电流 Average forward current	T _C =150°C (TO-220)	I _{F(AV)}	20	A
	T _C =125°C (TO-220F TO-220HF)		10	
正向峰值浪涌电流 Surge non repetitive forward current (额定负载 8.3ms 半正弦波—按 JEDEC 方法) 8.3 ms single half-sine-wave (JEDEC Method)		I _{FSM}	200	A
最高结温 Maximum junction temperature		T _J	175	°C
储存温度 Storage temperature range		T _{STG}	-40~+150	°C

电特性 ELECTRICAL CHARACTERISTICS

项 目 Parameter	测试条件 Tests conditions		最小值 Value(min)	典型值 Value(typ)	最大值 Value(max)	单 位 Unit
I _R	T _j =25°C	V _R =V _{RRM}			10	μA
	T _j =125°C				5	mA
V _F	T _j =25°C	I _F =10A		0.83	0.9	V
	T _j =125°C			0.68	0.75	V

热特性 THERMAL CHARACTERISTICS

项 目 Parameter	符 号 Symbol	最小值 Value(min)	最大值 Value(max)	单 位 Unit
结到管壳的热阻 Thermal resistance from junction to case	R _{th(j-c)}		2.2 3.0 3.0	°C/W
	TO-220		2.2	
	TO-220F		3.0	
	TO-220HF		3.0	

特征曲线 ELECTRICAL CHARACTERISTICS (curves)

I_F vs V_F

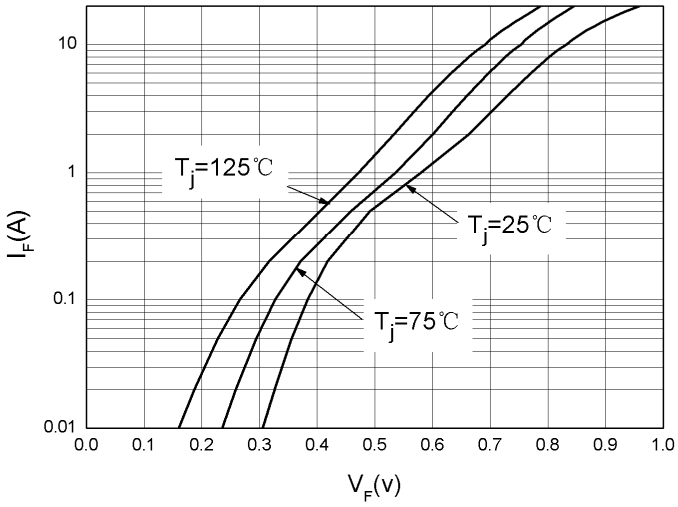

I_R vs V_R

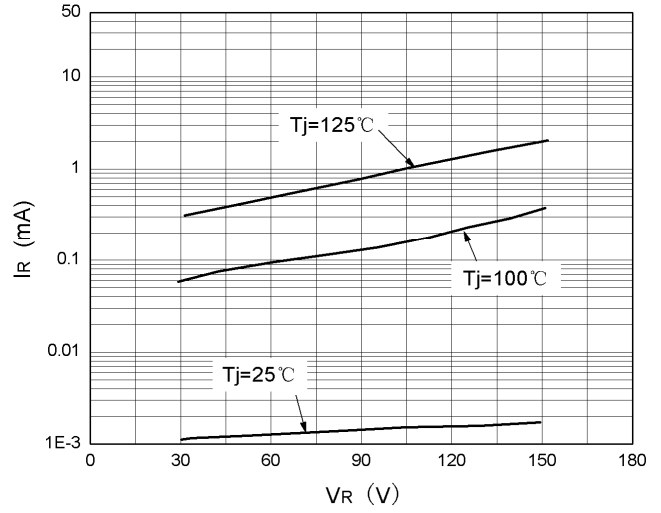

$I_F(AV)$ vs T_C

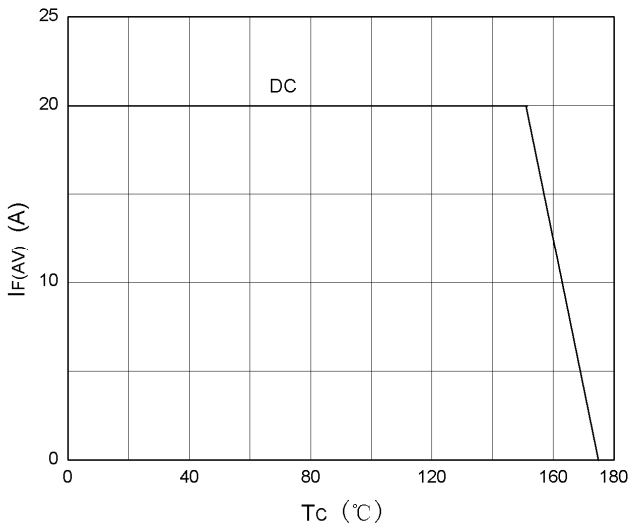

C_T vs V_R

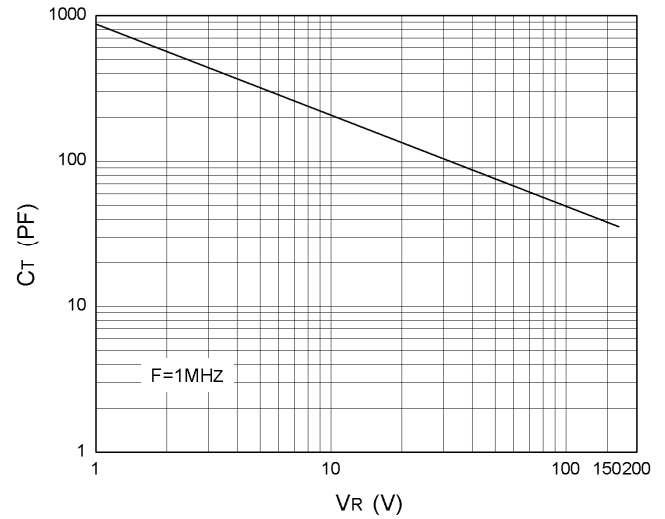

外形尺寸 PACKAGE MECHANICAL DATA

TO-220

单位 Unit : mm

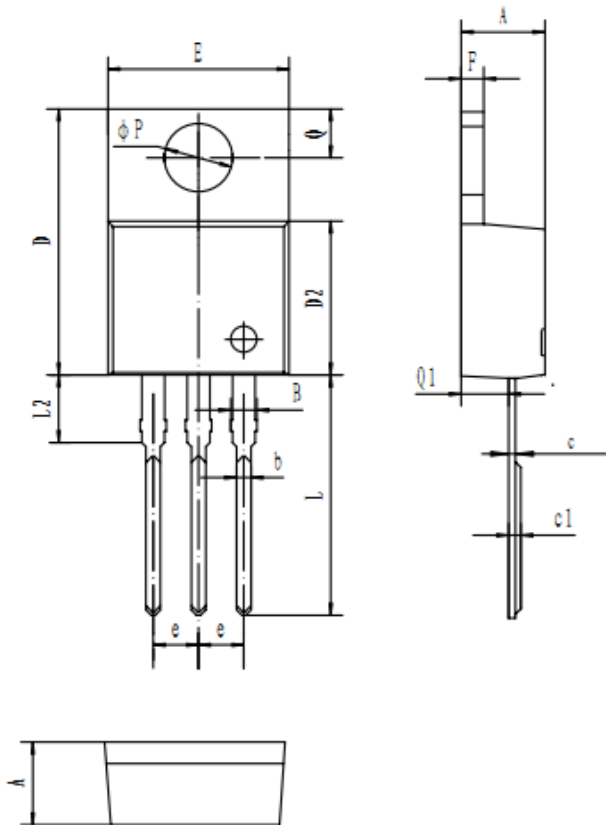

符号 symbol	MIN	MAX
A	4.40	4.80
B	1.10	1.40
b	0.70	0.95
c	0.28	0.48
c1	0.32	0.52
D	14.45	16.00
D2	8.20	9.20
E	9.60	10.40
e	2.39	2.69
F	1.20	1.35
L	13.05	14.05
L2	3.70	3.90
Q	2.40	3.00
Q1	2.20	2.90
P	3.50	4.00

外形尺寸 PACKAGE MECHANICAL DATA

TO-220F

单位 Unit : mm

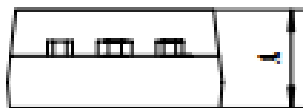
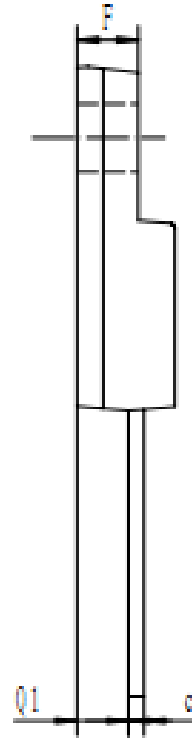
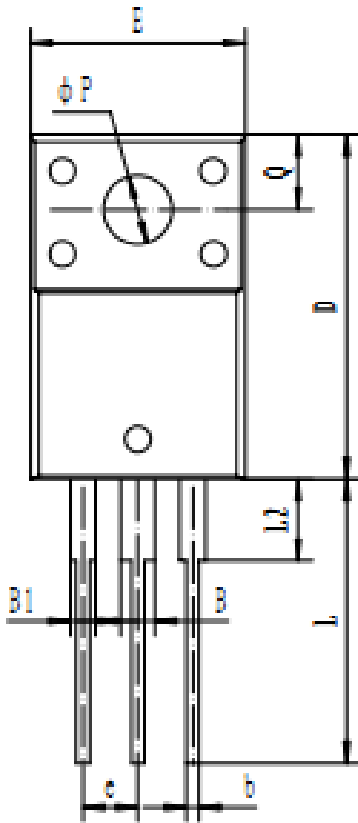

符号 Symbol	Min	Max
A	4.3	4.7
B	1.5	1.75
B1	1.1	1.35
b	0.5	0.75
c	0.5	0.75
D	14.5	15.5
E	9.96	10.36
e	2.54 (typ)	
F	2.8	3.2
L	12.7	13.7
L2	3.6	4.0
ΦP	3.3	3.7
Q	2.5	2.9
Q1	2.5	2.9

外形尺寸 PACKAGE MECHANICAL DATA

TO-220HF

单位 Unit : mm

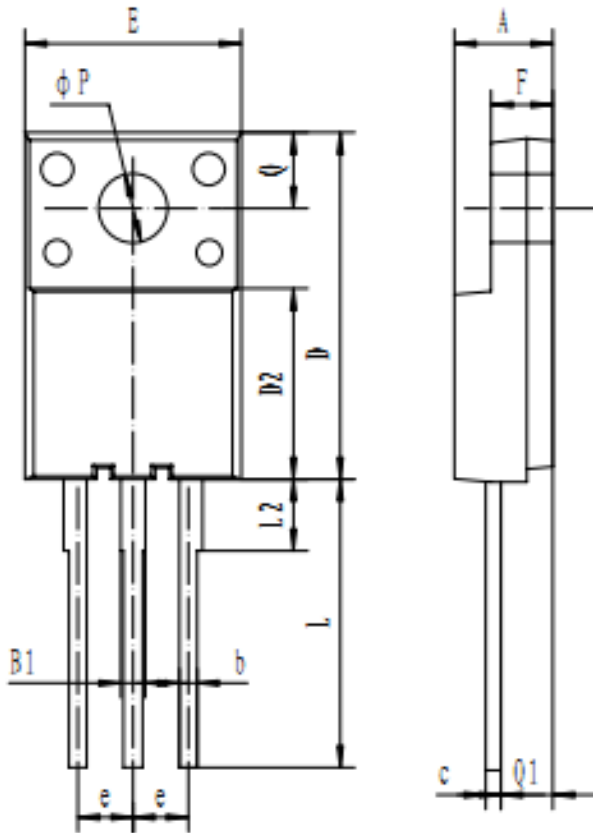

符号 Symbol	Min	Max
A	4.0	5.0
B1	0.87	1.27
b	0.72	0.92
c	0.5	0.70
D	15.0	16.5
D2	7.8	9.4
E	9.62	10.62
e	2.54(typ)	
F	2.3	3.3
L	12.0	14.0
L2	3.1	3.5
ΦP	3.0	3.4
Q	3.15	3.55
Q1	2.2	2.5

