



## Dual Schottky Barrier Rectifier

### Reverse Voltage 45V , Forward Current 20A

#### Features

- ◆ Plastic package has Underwriters Laboratory Flammability Classification 94V-0
- ◆ Dual rectifier construction, positive center tap
- ◆ Metal silicon junction, majority carrier conduction
- ◆ Low power loss, high efficiency
- ◆ Guardring for overvoltage protection
- ◆ For use in low voltage, high frequency inverters, free wheeling, and polarity protection applications
- ◆ High temperature soldering guaranteed:  
250°C/10 seconds, 0.25" (6.35mm) from case

#### Mechanical Data

- ◆ Case: JEDEC TO-220AB, TO-220F , TO-263AB molded plastic body
- ◆ Terminals: Plated leads, solderable per MIL-STD-750, Method 2026
- ◆ Polarity: As marked
- ◆ Mounting Position: Any
- ◆ Mounting Torque: 10 in-lbs maximum
- ◆ Weight: 0.08 ounce, 2.24 grams

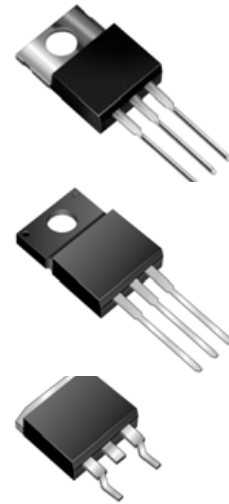

#### TO-220AB

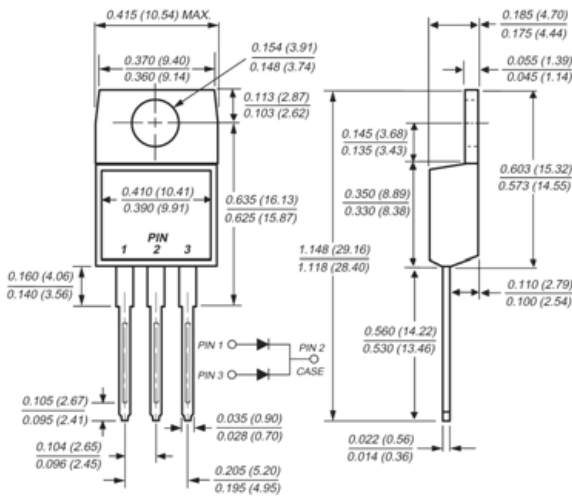

#### TO-220F

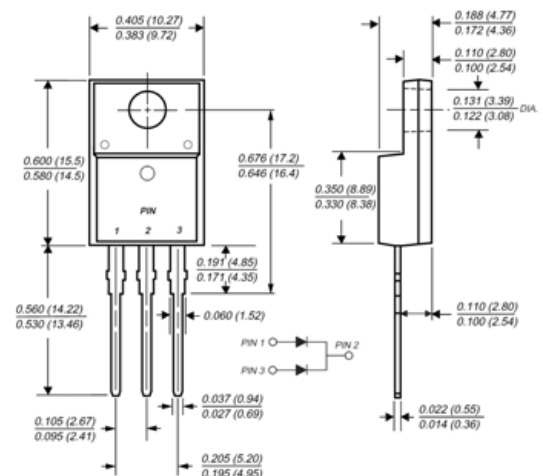

#### TO-263AB(D<sup>2</sup>PAK)

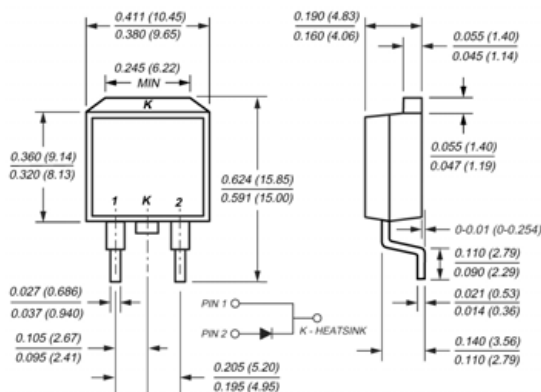

#### Mounting Pad Layout TO-263AB

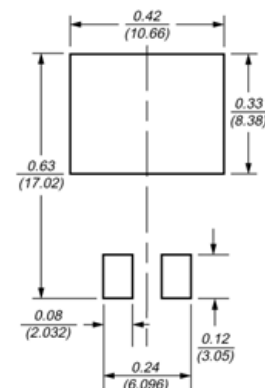

Dimensions in inches and (millimeters)



**Maximum Ratings and Electrical Characteristics**

( T<sub>C</sub> = 25°C unless otherwise noted )

Parameter	Symbol	MBR2035CT	MBR2045CT	MBR2050CT	MBR2060CT	Unit
Maximum repetitive peak reverse voltage	V <sub>RRM</sub>	35	45	50	60	Volts
Working peak reverse voltage	V <sub>RWM</sub>	35	45	50	60	Volts
Maximum DC blocking voltage	V <sub>DC</sub>	35	45	50	60	Volts
Maximum average forward rectified current at T <sub>C</sub> =135°C	I <sub>F(AV)</sub>	Total device Per leg		20 10		Amps
Peak repetitive forward current per leg at (rated V <sub>R</sub> , sq. wave, 2.KHz) at T <sub>C</sub> =135°C	I <sub>FRM</sub>			20		Amps
Peak forward surge current 8.3ms single half sine-wave superimposed on rated load (JEDEC Method) per leg	I <sub>FSM</sub>			150		Amps
Peak repetitive reverse surge current per leg at t <sub>p</sub> = 2.0us, 1KHz	I <sub>RRM</sub>	1.0		0.5		Amps
Voltage rate of change (rated V <sub>R</sub> )	dv/dt			10,000		V/us
Maximum instantaneous forward voltage per leg (Note 4) at I <sub>F</sub> =10A, T <sub>C</sub> =25°C at I <sub>F</sub> =10A, T <sub>C</sub> =125°C at I <sub>F</sub> =20A, T <sub>C</sub> =25°C at I <sub>F</sub> =20A, T <sub>C</sub> =125°C	V <sub>F</sub>	0.70 0.57 0.84 0.72		0.80 0.70 0.95 0.85		Volt
Maximum reverse current at rated DC blocking voltage per leg (Note 4) T <sub>C</sub> =25°C T <sub>C</sub> =125°C	I <sub>R</sub>	0.1 15		0.15 150		mA
Thermal resistance from junction to case per leg	R <sub>θJC</sub>			MBR 2.0 / MBRF 5.0 / MBRB 2.0		°C/W
RMS Isolation voltage (MBRF type only) from terminals to heatsink with t = 1.0 second, RH ≤ 30%	V <sub>ISOL</sub>			4500 (Note 1) 3500 (Note 2) 1500 (Note 3)		Volts
Operating junction temperature range	T <sub>J</sub>			-55 to +150		°C
Storage temperature range	T <sub>STG</sub>			-55 to +150		°C

- Notes:**
1. Clip mounting (on case), where lead does not overlap heatsink with 0.110" offset
  2. Clip mounting (on case), where leads do overlap heatsink
  3. Screw mounting with 4-40 screw, where washer diameter is < 4.9 mm (0.19")
  4. Pulse test: 300us pulse width, 1% duty cycle



### RATINGS AND CHARACTERISTIC CURVES

( $T_A = 25^\circ\text{C}$  unless otherwise noted)

