

Dual Common Cathode High-Voltage Schottky Rectifier, 40A (20A x 2), 100V



FEATURES

- 175°C T_J operation
- High frequency operation
- Low forward voltage drop
- High purity, high temperature epoxy encapsulation for enhanced mechanical strength and moisture resistance
- Guard ring for enhanced ruggedness, long term reliability and overvoltage protection
- Compliant to RoHS
- Designed and qualified according to JEDEC-JESD47
- Solder bath temperature 260°C maximum, 40 s

DESCRIPTION

The **MBR40100PT** Schottky rectifier has been optimized for low reverse leakage at high temperature. The proprietary barrier technology allows for reliable operation up to 175°C junction temperature.

APPLICATIONS

- Switching mode power supplies
- DC to DC converters
- Freewheeling diodes
- Reverse battery protection.

MECHANICAL DATA

Case: TO-247AB (TO-3P)

Molding compound meets UL 94 V-O flammability rating

Terminals: Mat tin plated leads, solderable per J-STD-002 and JESD 22-B102

Polarity: As marked

Mounting Torque: 10 in-lbs maximum



PRODUCT SUMMARY

I _{F(AV)}	20A x 2
V _R	100V
V _F at I _F =20 A at 125°C	0.67V
I _{RM} max.	6 mA at 125°C
T _J max.	175°C
Diode variation	Dual dice
E _{AS}	11.25 mJ

MAJOR RATINGS AND CHARACTERISTICS

SYMBOL	CHARACTERISTICS	VALUE	UNIT
I _{F(AV)}	Rectangular waveform	20 x 2	A
V _R		100	V
I _{FSM}	t _p = 8.3ms, single half sine-wave	300	A
V _F	20 A _{pk} , T _J = 125°C	0.67	V
T _J	Range	-65 to 175	°C

VOLTAGE RATINGS

SYMBOL	PARAMETER	VALUE	UNIT
V _R	Maximum DC reverse voltage	100	V
V _{RWM}	Maximum working peak reverse voltage		
V _{DC}	Maximum DC blocking voltage		

ABSOLUTE MAXIMUM RATINGS					
PARAMETER	SYMBOL	TEST CONDITIONS	VALUE	UNIT	
Maximum average forward current <small>per device per diode</small>	$I_{F(AV)}$	50% duty cycle at $t_c=144^\circ\text{C}$, rectangular waveform	40		A
			20		
Non-repetitive peak surge current	I_{FSM}	Surge applied at rated load condition half wave single phase 60 Hz	300		A
Non-repetitive avalanche energy, per diode	E_{AS}	$T_J = 25^\circ\text{C}$, $L = 5.6\text{mH}$, $I_{AS} = 2\text{A}$	11.25		mJ
Repetitive avalanche current	I_{AR}	Current decaying linearly to zero in $1\ \mu\text{s}$ Frequency limited by T_J maximum $V_A = 1.5 \times V_R$ typical	0.75		A

ELECTRICAL SPECIFICATIONS						
PARAMETER	SYMBOL	TEST CONDITIONS	TYP.	MAX.	UNIT	
Maximum forward voltage drop	$V_{FM}^{(1)}$	$I_F = 20\text{A}$	$T_J = 25^\circ\text{C}$	0.72	0.80	V
		$I_F = 40\text{A}$		0.85	0.90	
		$I_F = 20\text{A}$	$T_J = 125^\circ\text{C}$	0.63	0.67	
		$I_F = 40\text{A}$		0.74	0.8	
Maximum instantaneous reverse current	$I_{RM}^{(2)}$	$T_J = 25^\circ\text{C}$	Rated DC voltage	-	0.1	mA
		$T_J = 125^\circ\text{C}$		2.5	6	
Maximum junction capacitance	C_T	$V_R = 5\ V_{DC}$ (test signal range 100 kHz to 1 MHz) 25°C	-	600	pF	

Note

- (1) Pulse test : 300 μs pulse width, 1% duty cycle
- (2) Pulse test : Pulse width $\leq 40\ \text{ms}$

THERMAL - MECHANICAL SPECIFICATIONS					
PARAMETER	SYMBOL	TEST CONDITIONS	VALUE	UNIT	
Maximum junction temperature range	T_J		-65 to 175		$^\circ\text{C}$
Maximum storage temperature range	T_{stg}		-65 to 175		
Maximum thermal resistance, junction to case (per diode)	R_{thJC}	DC operation	1.25		$^\circ\text{C/W}$
Typical thermal resistance, case to heatsink	R_{thCS}	Mounting surface, smooth and greased	0.24		
Approximate weight			6.2		g
			0.22		oz.
Mounting torque	<small>minimum maximum</small>		6 (5)		kgf · cm (lbf · in)
			12 (10)		
Marking device		Case style TO-247AB	MBR40100PT		

Ordering Information Table

Device code

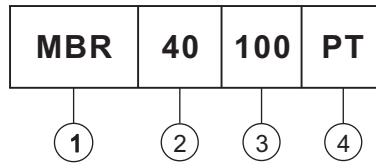

- 1 - Schottky MBR series
- 2 - Current rating (40 = 40A, 20A x 2)
- 3 - Voltage ratings, 100=100V
- 4 - Circuit configuration, Center tap common cathode, TO-247AB series package

BATINGS AND CHARACTERISTICS CURVES ($T_A = 25^\circ\text{C}$ unless otherwise noted)

Fig.1 Forward current derating curve

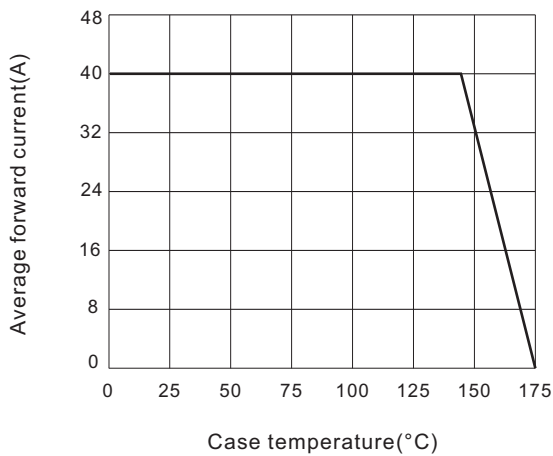

Fig.2 Maximum non-repetitive peak forward surge current per diode

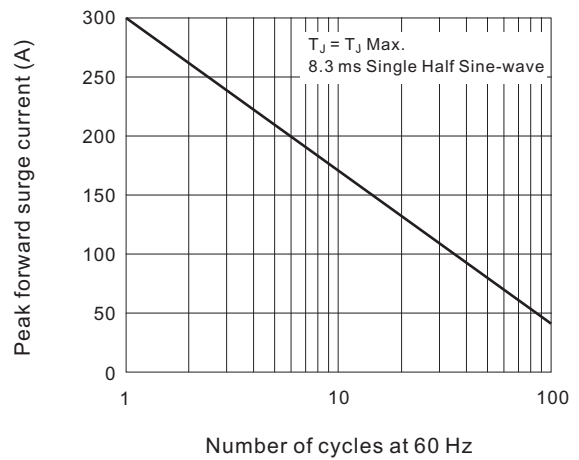

Fig.3 Typical instantaneous forward characteristics per diode

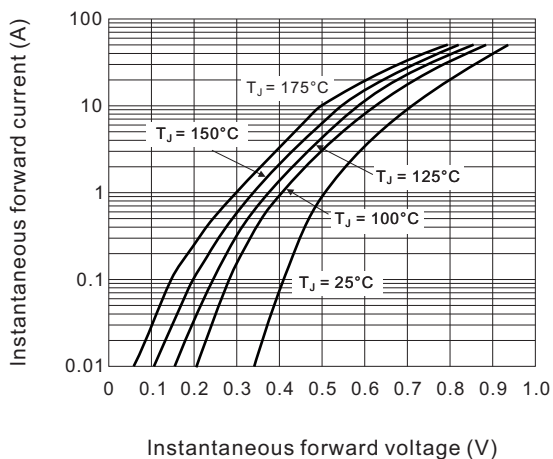

Fig.4 Typical reverse characteristics per diode

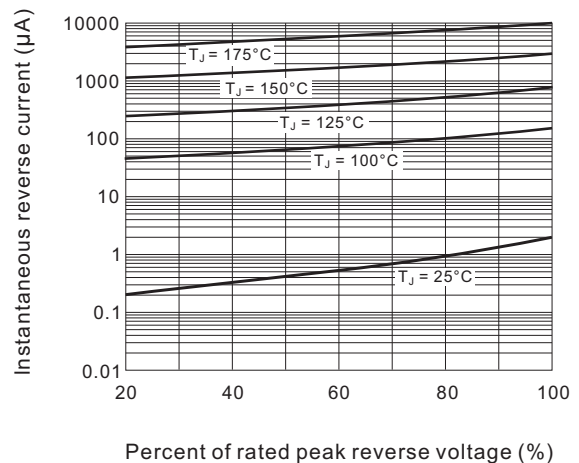

Fig.5 Typical junction capacitance per diode

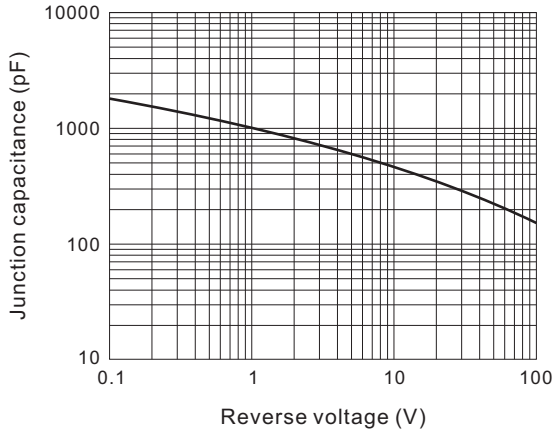
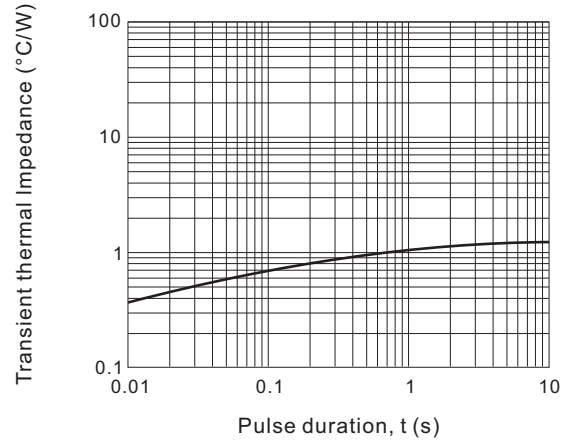
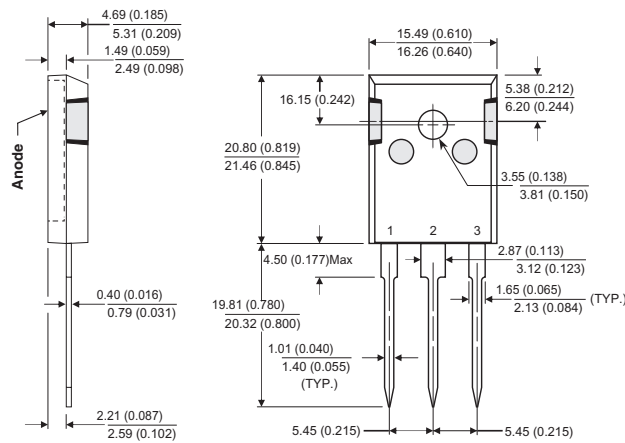

Fig.6 Typical transient thermal Impedance per diode



TO-247AB



All dimensions in millimeters (inches)

