

High Power Schottky Barrier Rectifier

Package Outline Dimensions (millimeters)

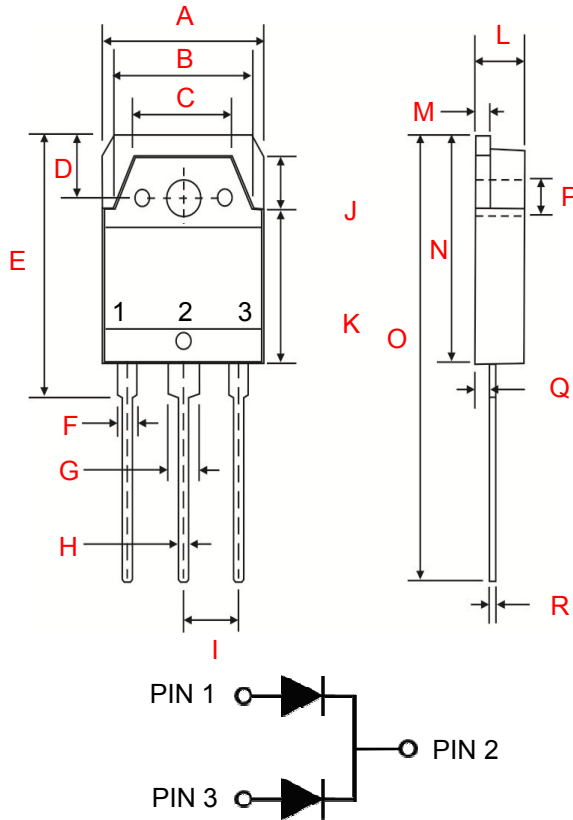

TO-3P		
Dim.	Min.	Max.
A	15.45	15.85
B	13.40	13.80
C	9.40	9.80
D	5.00 REF	
E	23.20	23.60
F	1.80	2.20
G	2.80	3.20
H	0.80	1.20
I	5.45 TYP	
J	5.15	5.50
K	13.70	14.10
L	4.60	5.00
M	1.45	1.65
N	20.30	20.60
O	39.90	40.30
P	3.3 REF	
Q	1.20	1.60
R	0.50	0.70
All Dimensions in millimeter		

Features

- High Current Capability
- Low Switching Noise
- High Surge Capability
- Low Power Loss & High Efficiency
- Guard Ring Protection
- Pd-free lead plating

Mechanical

- Molded Plastic Low profile TO-3P
- Plastic materials used carries underwriters laboratory flammability classification 94V-0
- Lead Temperature for Soldering Purposes : 265°C Max. for 10 Seconds
- Device Weight : Approximated 5.6 grams

Maximum Ratings & Electrical Characteristics ($T_A = 25^\circ\text{C}$ unless otherwise specified)

Parameter	Symbol	MBR 40100PT	MBR 40150PT	MBR 40200PT	Units
DC Blocking Voltage	V_{RM}	100	150	200	Volts
Working Peak Reverse Voltage	V_{RWM}	70	105	140	
Peak Repetitive Reverse Voltage	V_{RRM}	100	150	200	
Average Rectified Output Current (Total Device)	I_O	40			Amps
Non-Repetitive Peak Forward Surge Current (Per Leg) (Surge applied at rated load conditions half wave, single phase, 60Hz)	I_{FSM}	350			Amps
Instantaneous Forward Voltage (Per Leg) $I_F = 20A, T_A = 25^\circ\text{C}$	V_F	0.85	0.87	0.9	Volts
Instantaneous Reverse Current (Per Leg) $V_R = V_{RRM}, T_A = 25^\circ\text{C}$ $V_R = V_{RRM}, T_A = 125^\circ\text{C}$	I_R	0.1			mA
		10			

NOTE : 1. Thermal resistance from junction to case per leg, with heatsink(1.35" x 0.95" x 0.18") Al-plate.

Thermal Characteristics ($T_A = 25^\circ\text{C}$ unless otherwise specified) (Per Leg)

Parameter	Symbol	Value	Units
Maximum Thermal Resistance Junction to Case	$R\theta_{JC}$	1.0	$^\circ\text{C} / \text{W}$
Operating & Storage Junction Temperature	T_J	150	$^\circ\text{C}$
	T_{STG}	- 65 to +150	

Ratings and Characteristics Curves ($T_A = 25^\circ\text{C}$ unless otherwise specified)

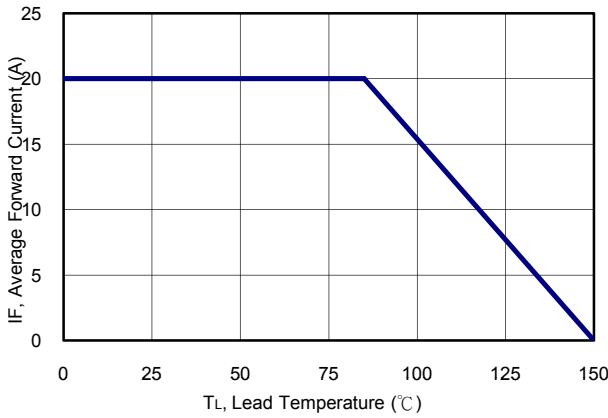

Figure 1: Current Derating Curves (Per Leg)

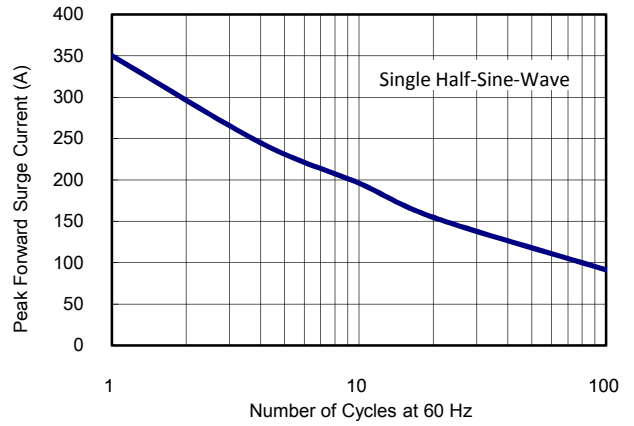

Figure 2: Peak Forward Surge Current (Per Leg)

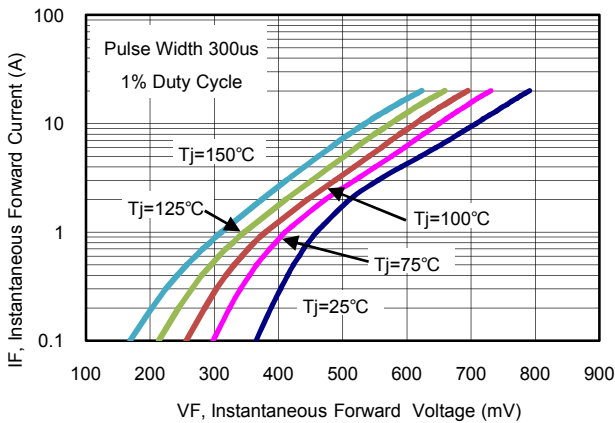

Figure 3: Typical Forward Characteristics (MBR40100PT) (Per Leg)

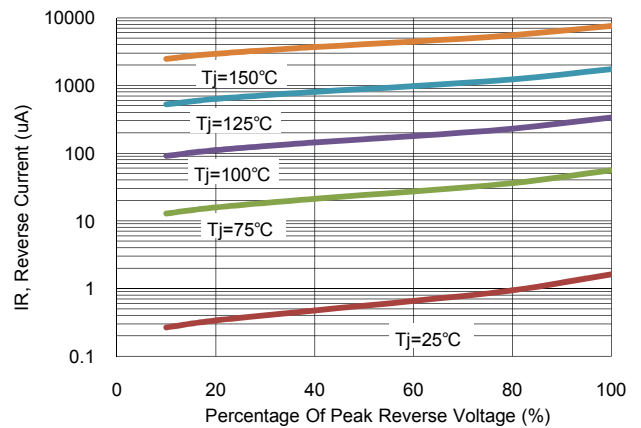

Figure 4: Typical Reverse Characteristics (MBR40100PT) (Per Leg)

Ratings and Characteristics Curves ($T_A = 25^\circ\text{C}$ unless otherwise specified)

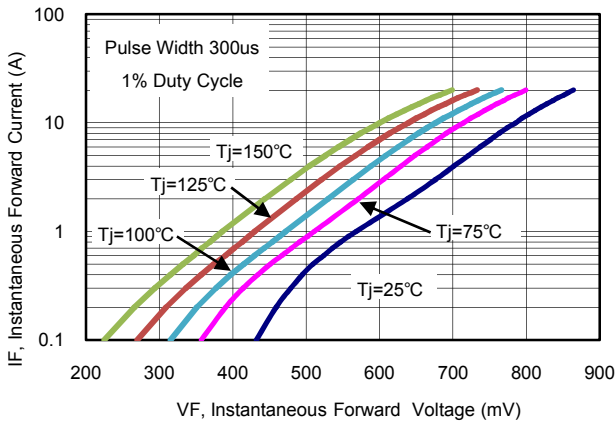

Figure 5: Typical Forward Characteristics (MBR40150PT) (Per Leg)

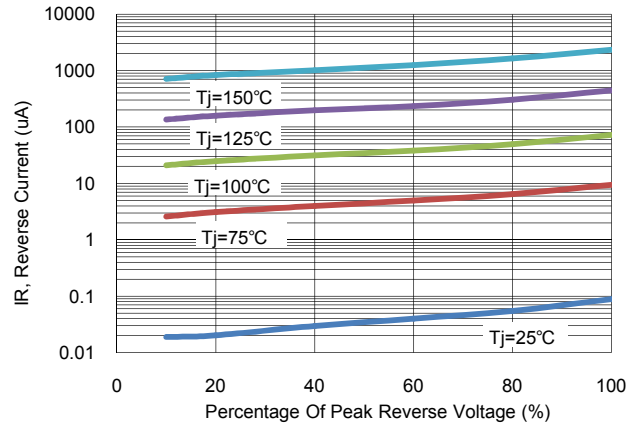

Figure 6: Typical Reverse Characteristics (MBR40150PT) (Per Leg)

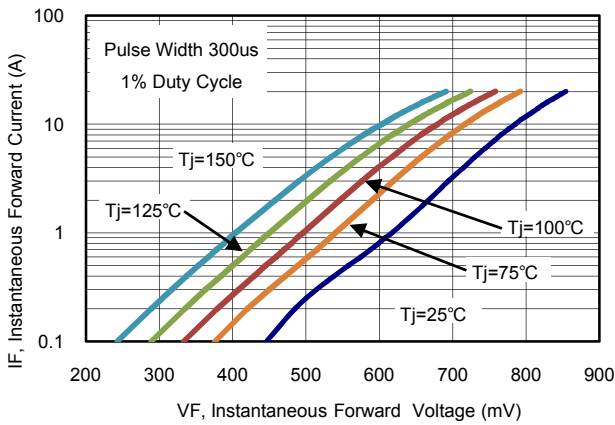

Figure 7: Typical Forward Characteristics (MBR40200PT) (Per Leg)

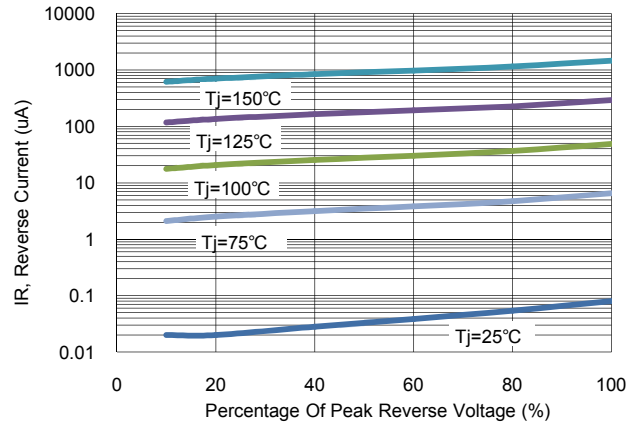
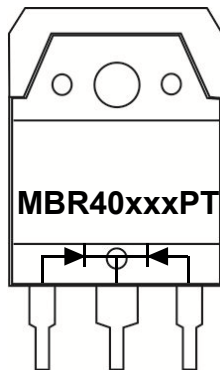

Figure 8: Typical Reverse Characteristics (MBR40200PT) (Per Leg)

Ordering information

Part Number	Package	Delivery mode
MBR40100PT THRU MBR40200PT	TO-3P	30 pieces / Tube

Marking Code Information

MBR40xxxPT = Product Type Marking Code

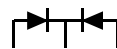
 = polarity

Disclaimer

All product specifications and data are subject to change without notice.

Sooner Power Semiconductor Co. Ltd., its affiliates, agents, and employees, and all persons acting on its or their behalf (collectively, "SPS"), disclaim any and all liability for any errors, inaccuracies or incompleteness contained herein or in any other disclosure relating to any product.

SPS disclaims any and all liability arising out of the use or application of any product described herein or of any information provided herein to the maximum extent permitted by law. The product specifications do not expand or otherwise modify SPS's terms and conditions of purchase, including but not limited to the warranty expressed therein, which apply to these products.

No license, express or implied, by estoppel or otherwise, to any intellectual property rights is granted by this document or by any conduct of SPS.

The products shown herein are not designed for use in medical, life- otherwise expressly indicated. Customers using or selling SPS products not expressly indicated for use in such applications do so entirely at their own risk and agree to fully indemnify SPS for any damages arising or resulting from such use or sales. Please contact authorized SPS personnel to obtain written terms and conditions regarding products designed for such applications.

Products names and markings noted herein may be trademarks of their respective owners.