

Mechanical Date

- Case:TO-220
- Case Material: Molded Plastic, UL Flammability Classification Rating 94V-0
- Terminals: Matte Tin Finish annealed over copper Lead frame. Solderable per MIL-STD-202
- Weight: 1.948 grams (approximate)

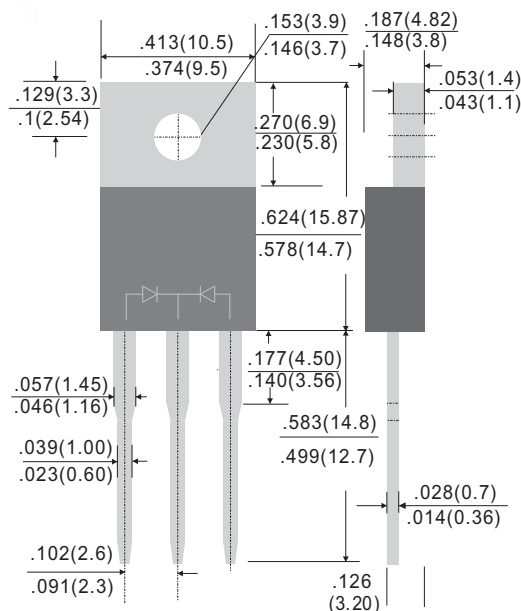

TO-220



Features

- Guard Ring for over voltage Protection
- High forward surge capability
- High frequency operation
- Component in accordance to RoHS 2002/95/EC
- **Pb-Free package is available**
RoHS product for packing code suffix "G"
Halogen free product for packing code suffix "H"

MAXIMUM RATINGS (TA=25°C unless otherwise noted)							
PARAMETER	SYMBOL	MBR4040CT	MBR4060CT	MBR40100CT	MBR40150CT	MBR40200CT	UNIT
Maximum repetitive peak reverse voltage	V_{RRM}	40	60	100	150	200	V
Maximum RMS voltage	V_{RMS}	28	42	70	105	140	V
Maximum DC blocking voltage	V_{DC}	40	60	100	150	200	V
Maximum average forward rectified current(Total) (Per Leg)	I_F	40 20					A
Peak forward surge current, 8.3ms single half sine-wave superimposed on rated load	I_{FSM}	250.0					A
Maximum Instantaneous Forward Voltage $I_F=20A @ 25^\circ C$	V_F	0.70	0.75	0.85	0.95		V
Maximum DC Reverse Current @ Tc=25°C at Rated DC Blocking Voltage @ Tc=100°C	I_R	0.5 30					mA
Typical Junction Capacitance(NOTE1)	C_j	300	200	150			pF
Typical Thermal Resistance	$R_{\theta JC}$	3					°C/W
Operating Temperature Range	T_J	-55 to +125			-55 to +150		°C
Storage Temperature Range	T_{STG}	-55 to +150					°C

NOTES:1.Measured at 1.0MHZ and applied reverse voltage of 4.0V DC

FIG. 1-TYPICAL FORWARD CURRENT DERATING CURVE

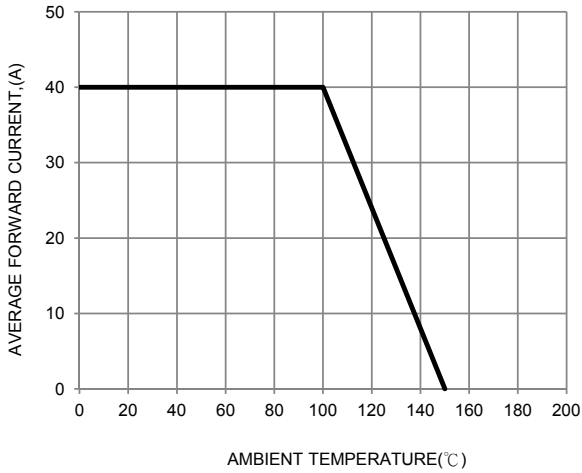

FIG. 2-TYPICAL FORWARD CHARACTERISTICS

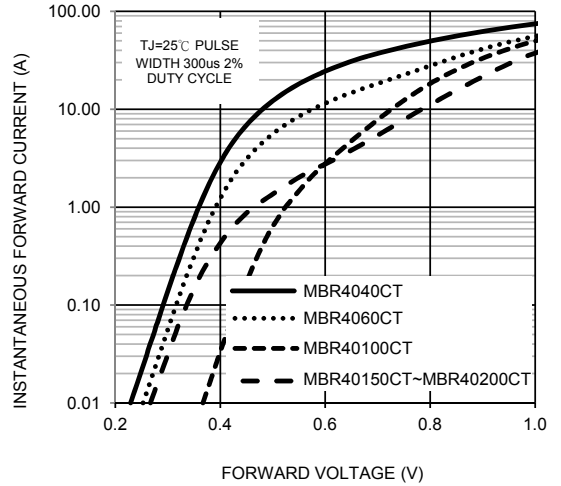

FIG. 3-MAXIMUM NON-REPETITIVE FORWARD SURGE CURRENT

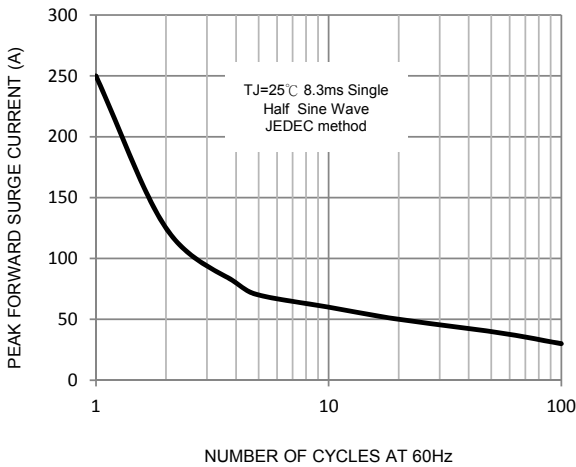

FIG. 4-TYPICAL REVERSE CHARACTERISTICS

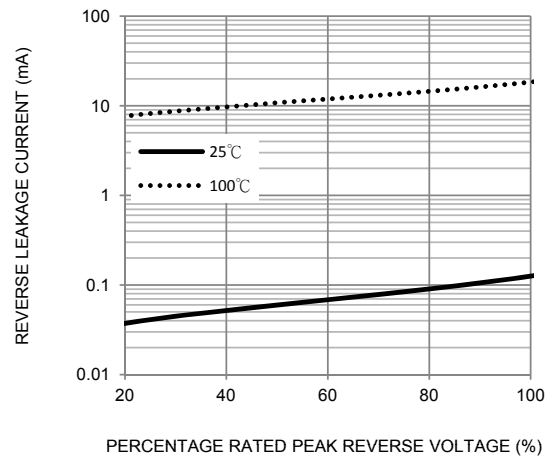

FIG. 5-TYPICAL JUNCTION CAPACITANCE

