



## Data Sheet

Customer :

Product : High Power Schottky Diode

Part No.: MBRB1040CT/MBRB1060CT/MBRB10100CT/MBRB10150CT  
MBRB10200CT/MBRB10250CT

Issued Date: 11-Jan-11

Edition : REV.A



VIKING TECH CORPORATION  
光韻科技股份有限公司

No.70, Kuanfu N. Rad.,  
Hsin Chu Industrial Park,  
Hukou Hsiang, Hsin Chu Hsien,  
303, Taiwan

TEL:886-3-5972931  
FAX:886-3-5972935•886-3-5973494  
E-mail:sales@viking.com.tw

VIKING TECH CORPORATION KAOHSIUNG BRANCH  
光韻科技股份有限公司高雄分公司

No.248-3, Sin-Sheng Rd., Cian-Jhen Dist., Kaohsiung,  
806, Taiwan

TEL:886-7-8217999  
FAX:886-7-8228229  
E-mail:sales@viking.com.tw

WUXI TMTEC CO., LTD.  
無錫泰銘電子有限公司

No.1A,(Xixia Road),Machinery & Industry Park,  
National Hi-Tech Industrial Development Zone of  
Wuxi, Wuxi, Jiangsu Province, China  
Zip Code:214028

TEL:86-510-85203339  
FAX:86-510-85203667•86-510-85203977  
E-mail:wuxisales@tmtec.com.tw

Produced by (QC)	Checked (QC)	Approved by (QC)	Prepared by (Sales)	Accepted by (Customer)
11-Jan-11	11-Jan-11	11-Jan-11	11-Jan-11	
<b>Kris</b>	<b>Ann</b>	<b>J.C Liu</b>		



## 10 Amperes Surface Mount High Power Schottky Barrier Rectifiers

### Voltage : 40 to 250Volts

#### ■ Features

- For use in low voltage, high frequency inverters, free wheeling and polarity protection applications
- Low power loss, high efficiency
- High current capability, low forward voltage drop
- High surge capability
- Guardring for over voltage protection
- Ultra high-speed switching
- Silicon epitaxial planar chip, metal silicon junction
- Lead-free parts meet environmental standards of MIL-STD-19500/228

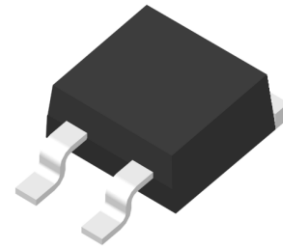

#### ■ Mechanical Data

**Epoxy** : UL94-V0 rated flame retardant  
**Case** : Molded plastic, TO-263/D<sup>2</sup>PAK  
**Terminals** : Solder plated, Solderable per MIL-STD-750, Method 2026  
**Polarity** : Indicated by cathode end  
**Mounting Position** : Any  
**Weight** : Approximated 1.70 gram  
**Package** : 50pcs per Tube

#### ■ Package Dimensions in millimeters(inches): TO-263/ D<sup>2</sup>PAK

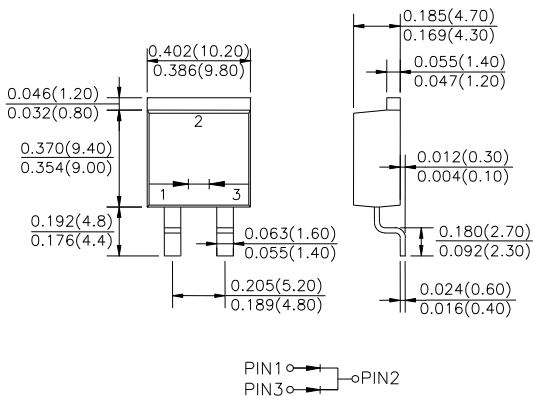

#### ■ Maximum Ratings And Electrical Characteristics

Rating at 25°C ambient temperature unless otherwise specified. Single phase, half wave, 60Hz, resistive or inductive load.  
 For capacitive load, derate current by 20%.

Parameter	Symbol	MBRB1040CT	MBRB1060CT	MBRB10100CT	MBRB10150CT	MBRB10200CT	MBRB10250CT	Unit
Marking Code		MBRB1040CT	MBRB1060CT	MBRB10100CT	MBRB10150CT	MBRB10200CT	MBRB10250CT	
Maximum Recurrent Peak Reverse Voltage	$V_{RRM}$	40	60	100	150	200	250	V
Maximum RMS Voltage	$V_{RMS}$	28	42	70	105	140	175	V
Maximum DC Blocking Voltage	$V_{DC}$	40	60	100	150	200	250	V
Maximum Forward Voltage@5A, $T_A=25^\circ\text{C}$		0.70	0.79	0.81	0.87	0.90	0.95	V
@5A, $T_A=125^\circ\text{C}$	$V_F$	0.57	0.70	0.71	0.77	0.80	0.85	
@10A, $T_A=25^\circ\text{C}$		0.84	0.95	0.95	1.0	1.0	-	
Operating Temperature	$T_J$	-50 ~ +150						°C

Parameter	Conditions	Symbol	Min.	Typ.	Max.	Unit
Forward Rectified Current	See Fig.1	$I_O$			10	A
Forward Surge Current	8.3ms single half sine-wave superimposed on rate load (JEDEC method)	$I_{FSM}$			125	A
Reverse Current	$V_R=V_{RRM}, T_A=25^\circ\text{C}$	$I_R$			0.1	mA
	$V_R=V_{RRM}, T_A=125^\circ\text{C}$				10	
Thermal Resistance	Junction to ambient	$R_{\theta JA}$		30		°C/W
Diode Junction Capacitance	f=1MHz and applied 4V DC reverse voltage	$C_J$		150		pF
Storage Temperature		$T_{STG}$	-50		+150	°C

## Rated and Characteristic Curve

Fig. 1 - Forward Current Derating Curve

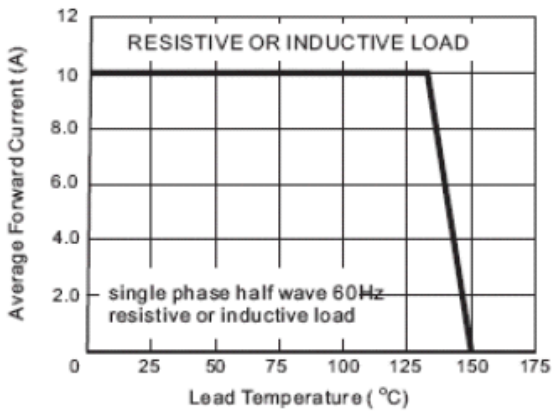

Fig. 2 - Maximum Non-Repetitive Peak Forward Surge Current

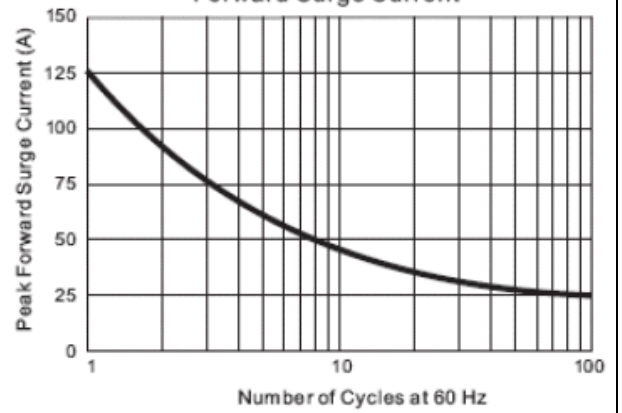

Fig. 3.1 - Typical Instantaneous Forward Characteristics

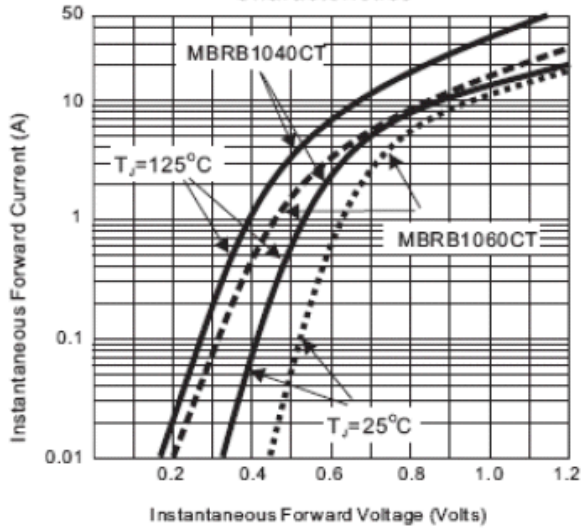

Fig. 3.2 - Typical Instantaneous Forward Characteristics

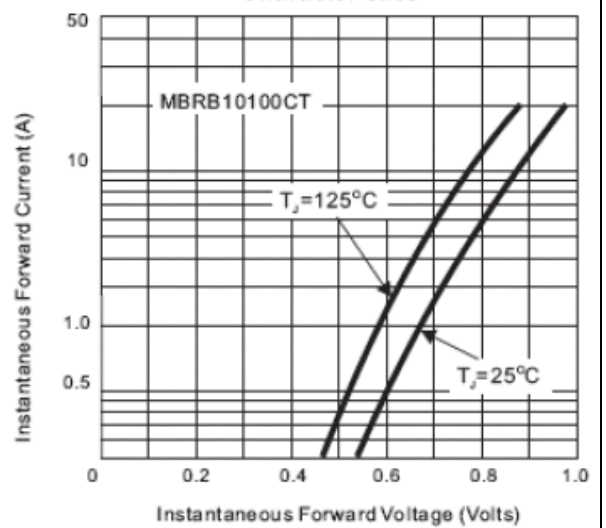

Fig. 3.3 - Typical Instantaneous Forward Characteristics

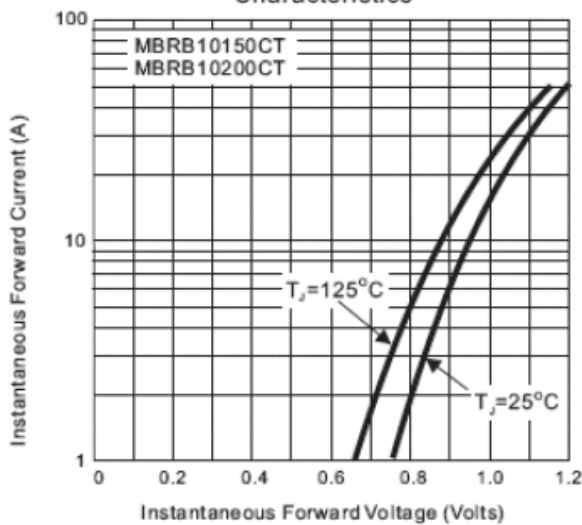

Fig. 4 - Typical Reverse Characteristics

