

Pb Free Plating Product

MBRB2035CT thru MBRB20200CT



20.0 Ampere Surface Mount Schottky Barrier Rectifiers

Features

- ✧ For surface mounted application
- ✧ Plastic material used carries Underwriters Laboratory Classifications 94V-0
- ✧ Metal silicon junction, majority carrier conduction
- ✧ Low power loss, high efficiency
- ✧ High current capability, low forward voltage drop
- ✧ High surge capability
- ✧ For use in low voltage, high frequency inverters, free wheeling, and polarity protection applications
- ✧ Guardring for overvoltage protection
- ✧ High temperature soldering guaranteed: 260°C/10 seconds at terminals

Mechanical Data

- ✧ Cases: JEDEC D²PAK /TO-263-2L molded plastic
- ✧ Terminals: Pure tin plated, lead free. solderable per MIL-STD-750, Method 2026
- ✧ Polarity: As marked
- ✧ Mounting position: Any
- ✧ Mounting torque: 5 in. - lbs. max
- ✧ Weight: 0.06 ounce, 1.70 grams

D²PAK

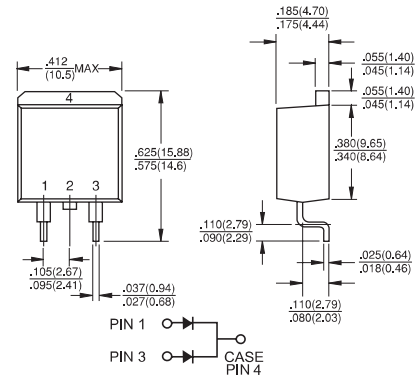

Dimensions in inches and (millimeters)

Maximum Ratings and Electrical Characteristics

Rating at 25 °C ambient temperature unless otherwise specified.
 Single phase, half wave, 60 Hz, resistive or inductive load.
 For capacitive load, derate current by 20%

Type Number	Symbol	MBRB 2035 CT	MBRB 2045 CT	MBRB 2050 CT	MBRB 2060 CT	MBRB 2090 CT	MBRB 20100 CT	MBRB 20200 CT	Units	
Maximum Recurrent Peak Reverse Voltage	V _{RRM}	35	45	50	60	90	100	200	V	
Maximum RMS Voltage	V _{RMS}	24	31	35	42	63	70	140	V	
Maximum DC Blocking Voltage	V _{DC}	35	45	50	60	90	100	200	V	
Maximum Average Forward Rectified Current at T _c =135°C	I _(AV)	20							A	
Peak Repetitive Forward Current (Rated V _R , Square Wave, 20KHz) at T _c =135°C	I _{FRM}	20							A	
Peak Forward Surge Current, 8.3 ms Single Half Sine-wave Superimposed on Rated Load (JEDEC method)	I _{FSM}	150							A	
Peak Repetitive Reverse Surge Current (Note 1)	I _{RRM}	1.0		0.5					A	
Maximum Instantaneous Forward Voltage at (Note 2) IF=10A, TC=25°C IF=10A, TC=125°C IF=20A, TC=25°C IF=20A, TC=125°C	V _F	-		0.80		0.85		0.99	V	
		0.57		0.70		0.75		0.87		
		0.84		0.95		0.95		1.23		
		0.72		0.85		0.85		1.10		
Maximum Instantaneous Reverse Current @ T _c =25°C at Rated DC Blocking Voltage @ T _c =125°C	I _R	0.1		0.1					mA	
		15		10			5.0		mA	
Voltage Rate of Change, (Rated V _R)	dV/dt	10,000							V/uS	
Typical Junction Capacitance	C _j	400			320				pF	
Typical Thermal Resistance Per Leg (Note 3)	R _{θJC}	1.0				2.0				°C/W
Operating Junction Temperature Range	T _J	-65 to +150							°C	
Storage Temperature Range	T _{STG}	-65 to +175							°C	

Notes: 1. 2.0us Pulse Width, f=1.0 KHz
 2. Pulse Test: 300us Pulse Width, 1% Duty Cycle
 3. Thermal Resistance from Junction to Case Per Leg, with Heatsink Size (4"x6"x0.25") Al-Plate.

FIG.1- FORWARD CURRENT DERATIN CURVE

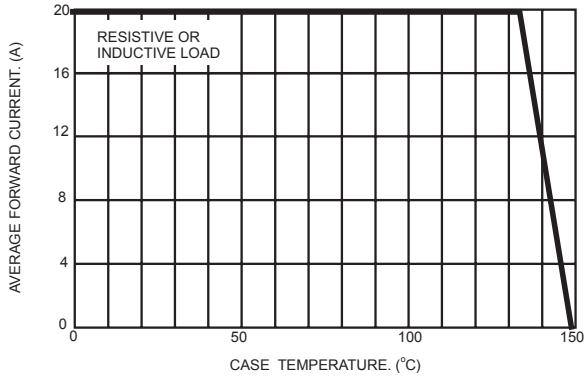

FIG.2- MAXIMUM NON-REPETITIVE FORWARD SURGE CURRENT PER LEG

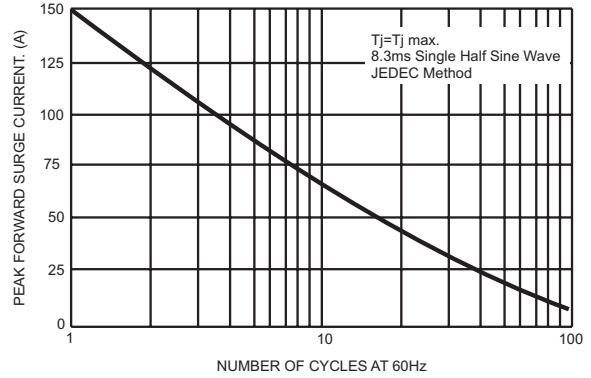

FIG.3- TYPICAL INSTANTANEOUS FORWARD CHARACTERISTICS PER LEG

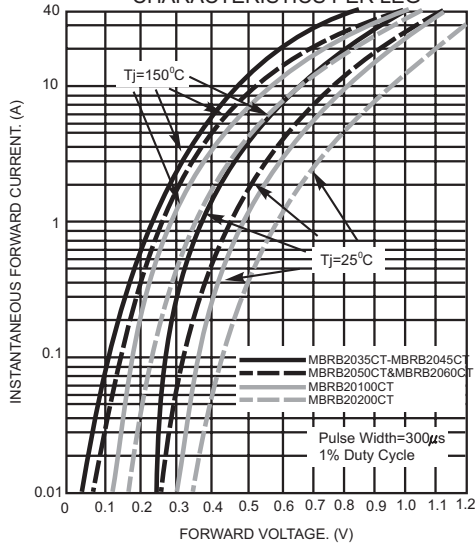

FIG.4- TYPICAL REVERSE CHARACTERISTICS PER LEG

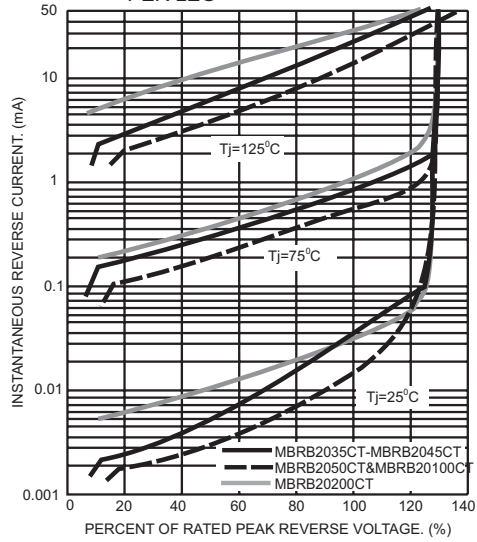

FIG.5- TYPICAL JUNCTION CAPACITANCE PER LEG

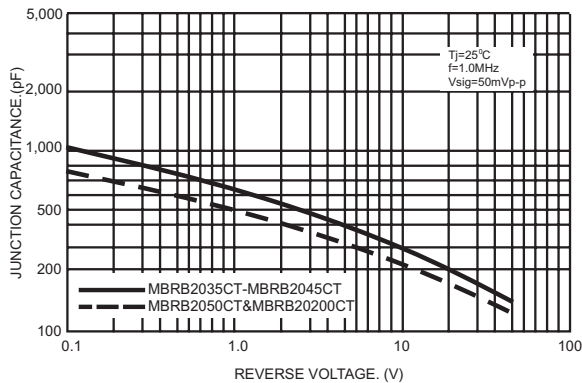

FIG.6- TYPICAL TRANSIENT THERMAL IMPEDANCE PER LEG

