

SCHOTTKY BARRIER RECTIFIER

VOLTAGE RANGE: 30 - 100 V
CURRENT: 15 A

FEATURES

- ◇ High surge capacity.
- ◇ For use in low voltage, high frequency inverters, free wheeling, and polarity protection applications.
- ◇ Metal silicon junction, majority carrier conduction.
- ◇ High current capacity, low forward voltage drop.
- ◇ Guard ring for over voltage protection.

MECHANICAL DATA

- ◇ Case: JEDEC ITO-220AB, molded plastic body
- ◇ Terminals: Leads, solderable per MIL-STD-750, Method 2026
- ◇ Polarity: As marked
- ◇ Position: Any
- ◇ Weight: 0.08ounce, 2.24 grams

ITO-220AB

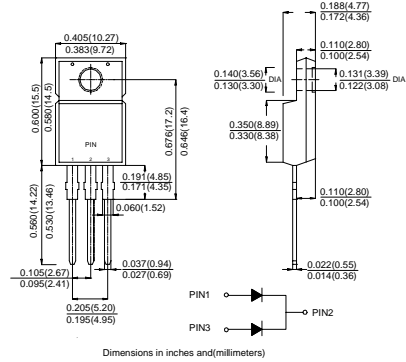

MAXIMUM RATINGS AND ELECTRICAL CHARACTERISTICS

Ratings at 25°C ambient temperature unless otherwise specified.

Single phase, half wave, 60Hz, resistive or inductive load. For capacitive load, derate current by 20%.

		MBRF 1530CT	MBRF 1535CT	MBRF 1540CT	MBRF 1545CT	MBRF 1550CT	MBRF 1560CT	MBRF 1580CT	MBRF 15100CT	UNITS
Maximum recurrent peak reverse voltage	V_{RRM}	30	35	40	45	50	60	80	100	V
Maximum RMS Voltage	V_{RMS}	21	25	28	32	35	42	56	70	V
Maximum DC blocking voltage	V_{DC}	30	35	40	45	50	60	80	100	V
Maximum average forward total device rectified current @ $T_c = 105^\circ\text{C}$	$I_{F(AV)}$	15								A
Peak forward surge current 8.3ms single half sine-wave superimposed on rated load	I_{FSM}	150								A
Maximum forward voltage ($I_F=7.5A, T_c=25^\circ\text{C}$) ($I_F=7.5A, T_c=125^\circ\text{C}$) (Note 1) ($I_F=15A, T_c=25^\circ\text{C}$) ($I_F=15A, T_c=125^\circ\text{C}$)	V_F		-				0.75	0.80		V
Maximum reverse current at rated DC blocking voltage @ $T_c=25^\circ\text{C}$ @ $T_c=125^\circ\text{C}$	I_R		0.1				1.0	0.1		m A
Maximum thermal resistance (Note2)	$R_{\theta JC}$	3.0								$^\circ\text{C/W}$
Operating junction temperature range	T_J	- 55 ---- + 150								$^\circ\text{C}$
Storage temperature range	T_{STG}	- 55 ---- + 150								$^\circ\text{C}$

NOTE: 1. Pulse test: 300µs pulse width, 1% duty cycle.

2. Thermal resistance from junction to case.

3. $T_c=100^\circ\text{C}$

www.galaxycn.com

FIG.1 – PEAK FORWARD SURGE CURRENT

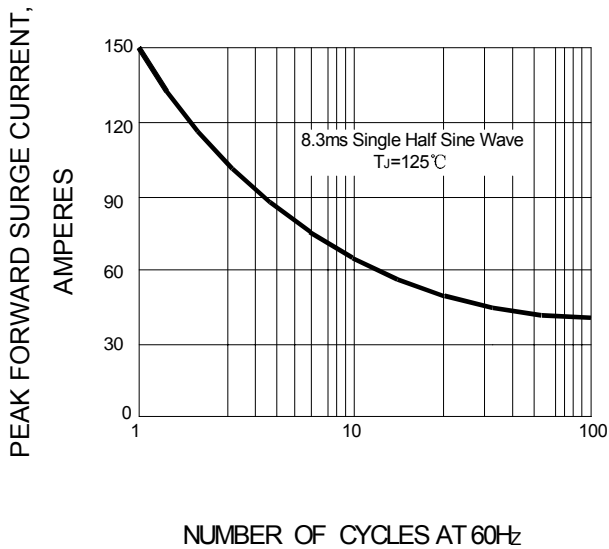

FIG.2 – FORWARD DERATING CURVE

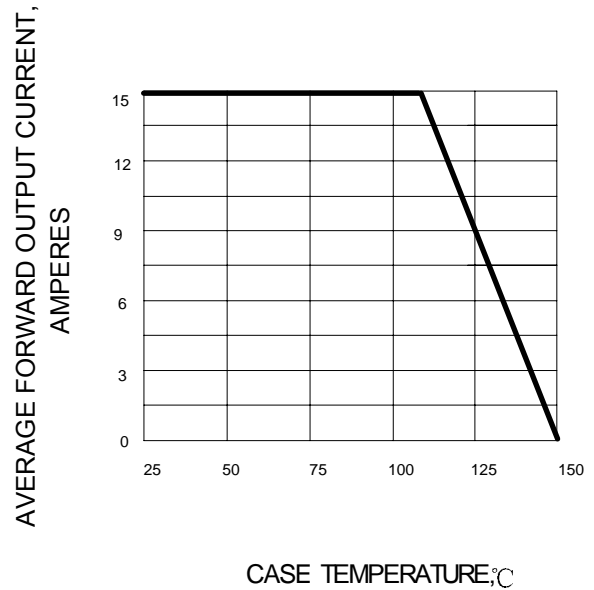

FIG.3 – TYPICAL FORWARD CHARACTERISTIC

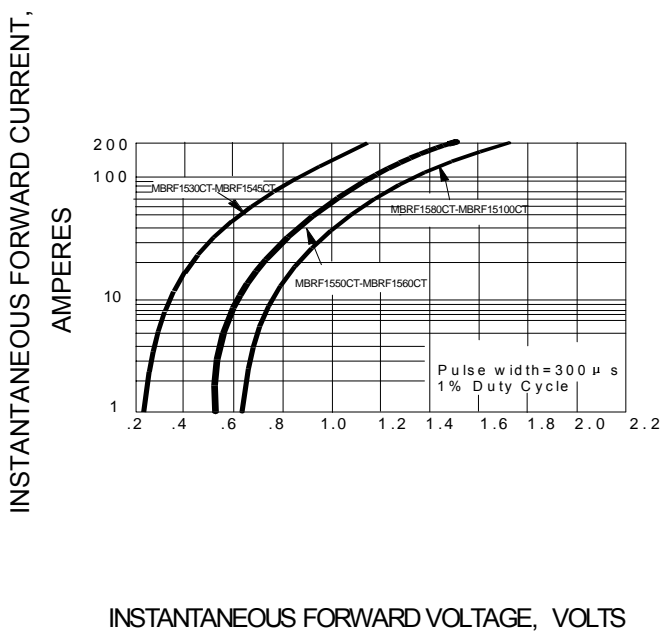

FIG.4 – TYPICAL REVERSE CHARACTERISTIC

