

## 6-Bit D Latch

The MC10E100E150 contains six D-type latches with differential outputs. When both Latch Enables (LEN1, LEN2) are LOW, the latch is transparent and input data transitions propagate through to the output. A logic HIGH on either LEN1 or LEN2 (or both) latches the data. The Master Reset (MR) overrides all other controls to set the Q outputs low.

- 800ps Max. Propagation Delay
- Extended 100E  $V_{EE}$  Range of - 4.2V to - 5.46V
- 75k $\Omega$  Input Pulldown Resistors

### LOGIC DIAGRAM

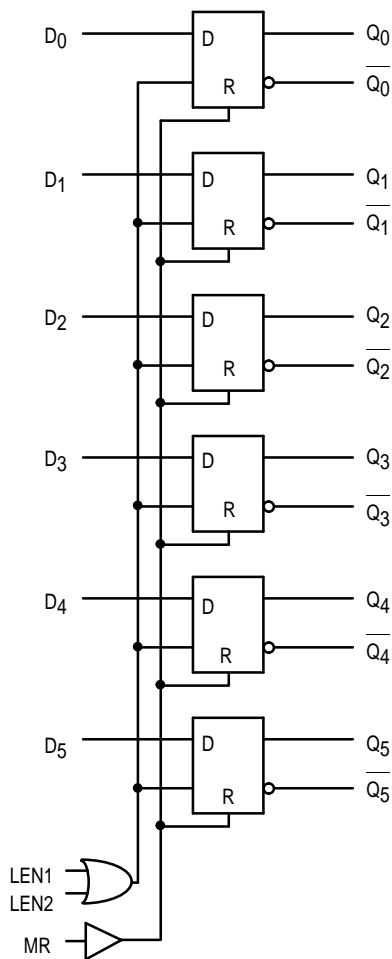

### PIN NAMES

| Pin                               | Function          |
|-----------------------------------|-------------------|
| D <sub>0</sub> – D <sub>5</sub>   | Data Inputs       |
| LEN1, LEN2                        | Latch Enables     |
| MR                                | Master Reset      |
| $\overline{Q_0} - \overline{Q_5}$ | True Outputs      |
| Q <sub>0</sub> – Q <sub>5</sub>   | Inverting Outputs |

**MC10E150**  
**MC100E150**

**6-BIT D LATCH**

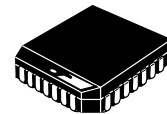

**FN SUFFIX**  
PLASTIC PACKAGE  
CASE 776-02

### Pinout: 28-Lead PLCC (Top View)

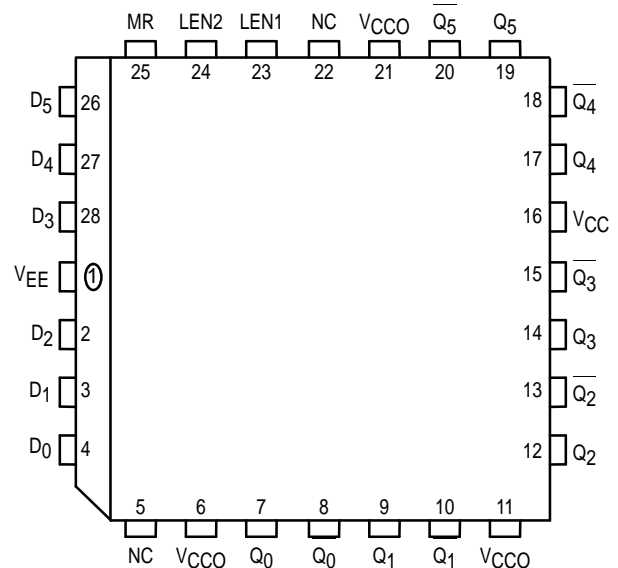

\* All VCC and VCCO pins are tied together on the die.



MC10E150 MC100E150

**DC CHARACTERISTICS** ( $V_{EE} = V_{EE}(\text{min})$  to  $V_{EE}(\text{max})$ ;  $V_{CC} = V_{CCO} = \text{GND}$ )

| Symbol   | Characteristic       | 0°C |     |     | 25°C |     |     | 85°C |     |     | Unit          | Condition |
|----------|----------------------|-----|-----|-----|------|-----|-----|------|-----|-----|---------------|-----------|
|          |                      | min | typ | max | min  | typ | max | min  | typ | max |               |           |
| $I_{IH}$ | Input HIGH Current   |     |     |     |      |     |     |      |     |     | $\mu\text{A}$ |           |
|          | D                    |     |     | 200 |      |     | 200 |      |     | 200 |               |           |
|          | LEN, MR              |     |     | 150 |      |     | 150 |      |     | 150 |               |           |
| $I_{EE}$ | Power Supply Current |     |     |     |      |     |     |      |     |     | $\text{mA}$   |           |
|          | 10E                  |     | 52  | 62  |      | 52  | 62  |      | 52  | 62  |               |           |
|          | 100E                 |     | 52  | 62  |      | 52  | 62  |      | 60  | 72  |               |           |

**AC CHARACTERISTICS** ( $V_{EE} = V_{EE}(\text{min})$  to  $V_{EE}(\text{max})$ ;  $V_{CC} = V_{CCO} = \text{GND}$ )

| Symbol                 | Characteristic              | 0°C |      |     | 25°C |      |     | 85°C |      |     | Unit        | Condition   |
|------------------------|-----------------------------|-----|------|-----|------|------|-----|------|------|-----|-------------|-------------|
|                        |                             | min | typ  | max | min  | typ  | max | min  | typ  | max |             |             |
| $t_{PLH}$<br>$t_{PHL}$ | Propagation Delay to Output |     |      |     |      |      |     |      |      |     | $\text{ps}$ |             |
|                        | D                           | 250 | 375  | 550 | 250  | 375  | 550 | 250  | 375  | 550 |             |             |
|                        | LEN                         | 375 | 500  | 700 | 375  | 500  | 700 | 375  | 500  | 700 |             |             |
|                        | MR                          | 450 | 625  | 750 | 450  | 625  | 750 | 450  | 625  | 750 |             |             |
| $t_s$                  | Setup Time                  |     |      |     |      |      |     |      |      |     | $\text{ps}$ |             |
|                        | D                           | 200 | 50   |     | 200  | 50   |     | 200  | 50   |     |             |             |
| $t_h$                  | Hold Time                   |     |      |     |      |      |     |      |      |     | $\text{ps}$ |             |
|                        | D                           | 200 | - 50 |     | 200  | - 50 |     | 200  | - 50 |     |             |             |
| $t_{RR}$               | Reset Recovery Time         | 750 | 650  |     | 750  | 650  |     | 750  | 650  |     | $\text{ps}$ | $\text{ps}$ |
| $t_{PW}$               | Minimum Pulse Width         |     |      |     |      |      |     |      |      |     | $\text{ps}$ |             |
|                        | MR                          | 400 |      |     | 400  |      |     | 400  |      |     |             |             |
| $t_{SKEW}$             | Within-Device Skew          |     | 50   |     |      | 50   |     |      | 50   |     | $\text{ps}$ | 1           |
| $t_r$<br>$t_f$         | Rise/Fall Times             |     |      |     |      |      |     |      |      |     | $\text{ps}$ |             |
|                        | 20 - 80%                    | 300 | 450  | 650 | 300  | 450  | 650 | 300  | 450  | 650 |             |             |

1. Within-device skew is defined as identical transitions on similar paths through a device.

OUTLINE DIMENSIONS

FN SUFFIX  
 PLASTIC PLCC PACKAGE  
 CASE 776-02  
 ISSUE D



NOTES:

- DATUMS -L-, -M-, AND -N- DETERMINED WHERE TOP OF LEAD SHOULDER EXITS PLASTIC BODY AT MOLD PARTING LINE.
- DIM G1, TRUE POSITION TO BE MEASURED AT DATUM -T-, SEATING PLANE.
- DIM R AND U DO NOT INCLUDE MOLD FLASH. ALLOWABLE MOLD FLASH IS 0.010 (0.250) PER SIDE.
- DIMENSIONING AND TOLERANCING PER ANSI Y14.5M, 1982.
- CONTROLLING DIMENSION: INCH.
- THE PACKAGE TOP MAY BE SMALLER THAN THE PACKAGE BOTTOM BY UP TO 0.012 (0.300). DIMENSIONS R AND U ARE DETERMINED AT THE OUTERMOST EXTREMES OF THE PLASTIC BODY EXCLUSIVE OF MOLD FLASH, TIE BAR BURRS, GATE BURRS AND INTERLEAD FLASH, BUT INCLUDING ANY MISMATCH BETWEEN THE TOP AND BOTTOM OF THE PLASTIC BODY.
- DIMENSION H DOES NOT INCLUDE DAMBAR PROTRUSION OR INTRUSION. THE DAMBAR PROTRUSION(S) SHALL NOT CAUSE THE H DIMENSION TO BE GREATER THAN 0.037 (0.940). THE DAMBAR INTRUSION(S) SHALL NOT CAUSE THE H DIMENSION TO BE SMALLER THAN 0.025 (0.635).

| DIM | INCHES    |       | MILLIMETERS |       |
|-----|-----------|-------|-------------|-------|
|     | MIN       | MAX   | MIN         | MAX   |
| A   | 0.485     | 0.495 | 12.32       | 12.57 |
| B   | 0.485     | 0.495 | 12.32       | 12.57 |
| C   | 0.165     | 0.180 | 4.20        | 4.57  |
| E   | 0.090     | 0.110 | 2.29        | 2.79  |
| F   | 0.013     | 0.019 | 0.33        | 0.48  |
| G   | 0.050 BSC |       | 1.27 BSC    |       |
| H   | 0.026     | 0.032 | 0.66        | 0.81  |
| J   | 0.020     | —     | 0.51        | —     |
| K   | 0.025     | —     | 0.64        | —     |
| R   | 0.450     | 0.456 | 11.43       | 11.58 |
| U   | 0.450     | 0.456 | 11.43       | 11.58 |
| V   | 0.042     | 0.048 | 1.07        | 1.21  |
| W   | 0.042     | 0.048 | 1.07        | 1.21  |
| X   | 0.042     | 0.056 | 1.07        | 1.42  |
| Y   | —         | 0.020 | —           | 0.50  |
| Z   | 2°        |       | 10°         |       |
| G1  | 0.410     | 0.430 | 10.42       | 10.92 |
| K1  | 0.040     | —     | 1.02        | —     |

Motorola reserves the right to make changes without further notice to any products herein. Motorola makes no warranty, representation or guarantee regarding the suitability of its products for any particular purpose, nor does Motorola assume any liability arising out of the application or use of any product or circuit, and specifically disclaims any and all liability, including without limitation consequential or incidental damages. "Typical" parameters which may be provided in Motorola data sheets and/or specifications can and do vary in different applications and actual performance may vary over time. All operating parameters, including "Typicals" must be validated for each customer application by customer's technical experts. Motorola does not convey any license under its patent rights nor the rights of others. Motorola products are not designed, intended, or authorized for use as components in systems intended for surgical implant into the body, or other applications intended to support or sustain life, or for any other application in which the failure of the Motorola product could create a situation where personal injury or death may occur. Should Buyer purchase or use Motorola products for any such unintended or unauthorized application, Buyer shall indemnify and hold Motorola and its officers, employees, subsidiaries, affiliates, and distributors harmless against all claims, costs, damages, and expenses, and reasonable attorney fees arising out of, directly or indirectly, any claim of personal injury or death associated with such unintended or unauthorized use, even if such claim alleges that Motorola was negligent regarding the design or manufacture of the part. Motorola and  are registered trademarks of Motorola, Inc. Motorola, Inc. is an Equal Opportunity/Affirmative Action Employer.

**How to reach us:**

**USA/EUROPE/Locations Not Listed:** Motorola Literature Distribution;  
P.O. Box 20912; Phoenix, Arizona 85036. 1-800-441-2447 or 602-303-5454

**MFAX:** RMFAX0@email.sps.mot.com – TOUCHTONE 602-244-6609  
**INTERNET:** <http://Design-NET.com>

**JAPAN:** Nippon Motorola Ltd.; Tatsumi-SPD-JLDC, 6F Seibu-Butsuryu-Center,  
3-14-2 Tatsumi Koto-Ku, Tokyo 135, Japan. 03-81-3521-8315

**ASIA/PACIFIC:** Motorola Semiconductors H.K. Ltd.; 8B Tai Ping Industrial Park,  
51 Ting Kok Road, Tai Po, N.T., Hong Kong. 852-26629298

