



**MOTOROLA**

# MC1372

## COLOR TV VIDEO MODULATOR

... an integrated circuit used to generate an RF TV signal from baseband color-difference and luminance signals.

The MC1372 contains a chroma subcarrier oscillator, a lead and lag network, a quasi-quadrature suppressed carrier DSB chroma modulator, an RF oscillator and modulator, and an LSTTL compatible clock driver with adjustable duty cycle.

The MC1372 is a companion part to the MC6847 Video Display Generator, providing and accepting the correct dc interconnection levels. This device may also be used as a general-purpose modulator with a variety of video signal generating devices such as video games, test equipment, video tape recorders, etc.

- Single 5.0 Vdc Supply Operation for NMOS and TTL Compatibility
- Minimal External Components
- Compatible with MC6847 Video Display Generator
- Sound Carrier Addition Capability
- Modulates Channel 3 or 4 Carrier with Encoded Video Signal
- Low Power Dissipation
- Linear Chroma Modulators for High Versatility
- Composite Video Signal Generation Capability
- Ground-Referenced Video Prevents Overmodulation

## COLOR TV VIDEO MODULATOR CIRCUIT

SILICON MONOLITHIC INTEGRATED CIRCUIT

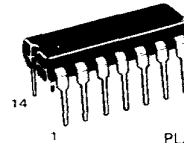

P SUFFIX  
PLASTIC PACKAGE  
CASE 646-05

### Pin Connections

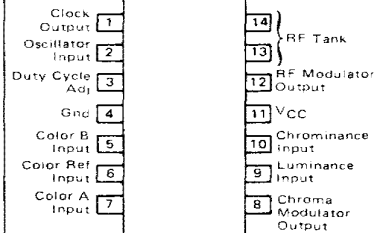
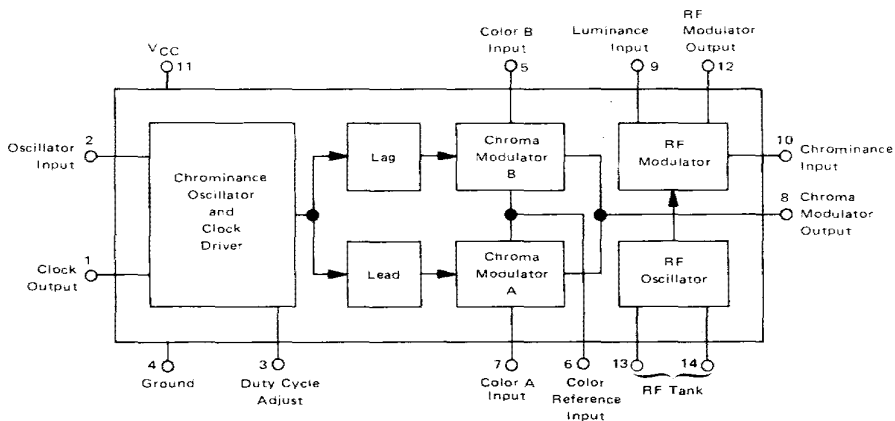

FIGURE 1 - BLOCK DIAGRAM



**MAXIMUM RATINGS** (T<sub>A</sub> = 25°C unless otherwise noted)

Rating	Value	Unit
Supply Voltage	8.0	Vdc
Operating Ambient Temperature Range	0 to +70	°C
Storage Temperature Range	-65 to +150	°C
Junction Temperature	150	°C
Power Dissipation, Package	1.25	Watts
Derate above 25°C	13	mW/°C

**RECOMMENDED OPERATING CONDITIONS**

Supply Voltage	5.0	Vdc
Luma Input Voltage – Sync Tip	1.0	Vdc
Peak White	0.35	
Color Reference Voltage	1.5	Vdc
Color A, B Input Voltage Range	1.0 to 2.0	Vdc

**ELECTRICAL CHARACTERISTICS** (V<sub>CC</sub> = +5 Vdc, T<sub>A</sub> = 25°C, Test Circuit 1 unless otherwise noted)

Characteristic	Min	Typ	Max	Unit
Operating Supply Voltage	4.75	5.0	5.25	Volts
Supply Current	–	25	–	mA

**CHROMA OSCILLATOR/CLOCK DRIVER** (Measured at Pin 1 unless otherwise noted)

Output Voltage	(V <sub>OL</sub> ) (V <sub>OH</sub> )	– 2.4	– –	0.4 –	Vdc
Rise Time (V1 = 0.4 to 2.4 Vdc)	–	–	50	ns	
Fall Time (V1 = 2.4 to 0.4 Vdc)	–	–	50	ns	
Duty Cycle Adjustment Range (V3 = 5.0 Vdc) (Measured at V1 = 1.4 V)	70	–	30	%	
Inherent Duty Cycle (No connection to Pin 3)	–	50	–	%	

**CHROMA MODULATOR** (V5 = V6 = V7 = 1.5 Vdc unless otherwise noted)

Input Common Mode Voltage Range (Pins 5, 6, 7)	0.8	–	2.3	Vdc
Oscillator Feedthrough (Measured at Pin 8)	–	15	31	mV (p-p)
Modulation Angle (#8/V7 = 2.0 Vdc) – #8/(V5 ± 2.0 Vdc)	85	100	115	degrees
Conversion Gain [V8/(V7 – V6), V8/(V5 – V6)]	–	0.6	–	V(p-p)/Vdc
Input Current (Pins 5, 6, 7)	–	–	-20	µA
Input Resistance (Pins 5, 6, 7)	100	–	–	kΩ
Input Capacitance (Pins 5, 6, 7)	–	–	5.0	pF
Chroma Modulator Linearity (V5 = 1.0 to 2.0 V; V7 = 1.0 to 2.0 V)	–	4.0	–	%

**RF MODULATOR**

Luma Input Dynamic Range (Pin 9, Test Circuit 2)	0	–	1.5	Volts
RF Output Voltage (f = 67.25 MHz, V9 = 1.0 V)	–	15	–	mVrms
Luma Conversion Gain (ΔV12/ΔV9; V9 = 0.1 to 1.0 Vdc) Test Circuit 2	–	0.8	–	V/V
Chroma Conversion Gain (ΔV12/ΔV10; V10 = 1.5 Vp-p; V9 = 1.0 Vdc) Test Circuit 2	–	0.95	–	V/V
Chroma Linearity (Pin 12, V10 = 1.5 Vp-p) Test Circuit 2	–	1.0	–	%
Luma Linearity (Pin 12, V9 = 0 to 1.5 Vdc) Test Circuit 2	–	2.0	–	%
Input Current (Pin 9)	–	–	-20	µA
Input Resistance (Pin 10)	–	800	–	Ω
Input Resistance (Pin 9)	100	–	–	kΩ
Input Capacitance (Pins 9, 10)	–	–	5.0	pF
Residual 920 kHz (Measured at Pin 12) See Note 1	–	50	–	dB
Output Current (Pin 12, V9 = 0 V) Test Circuit 2	–	1.0	–	mA

**TEMPERATURE CHARACTERISTICS** (V<sub>CC</sub> = 5 Vdc, T<sub>A</sub> = 0 to 70°C, IC only)

Chroma Oscillator Deviation (f <sub>o</sub> = 3.579545 MHz)	–	±50	–	Hz
RF Oscillator Deviation (f <sub>o</sub> = 67.25 MHz)	–	±250	–	kHz
Clock Drive Duty Cycle Stability	±5.0	–	–	%

NOTE 1. V9 = 1.0 Vdc, V<sub>C</sub> = 300 mV(p-p) @ 3.58 MHz,

V<sub>S</sub> = 250 mV(p-p) @ 4.5 MHz, Source Impedance = 75 Ω.

FIGURE 2 – TEST CIRCUIT 1

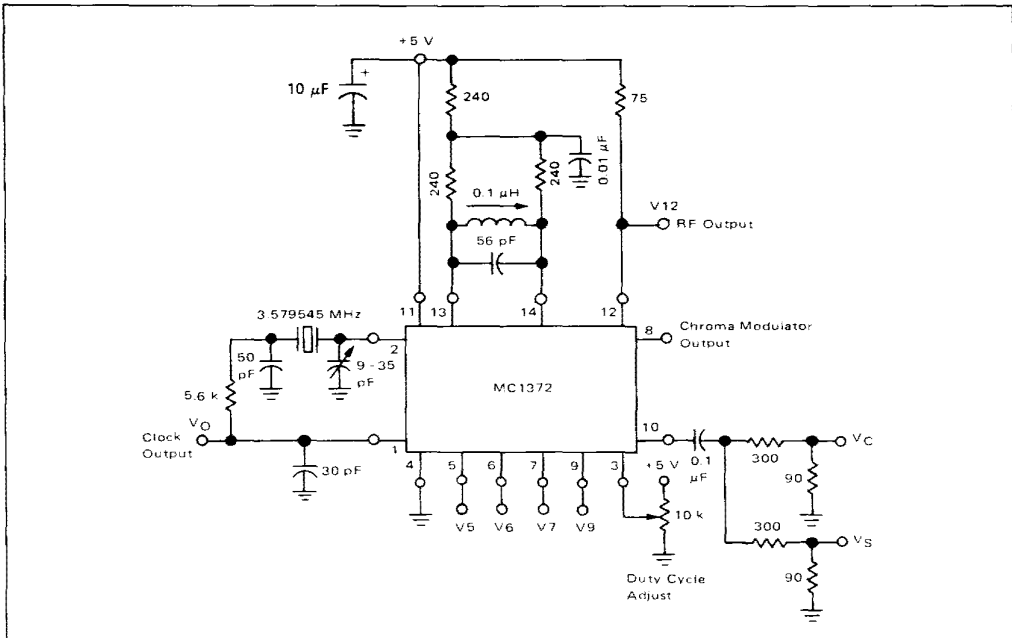

3

FIGURE 3 – TEST CIRCUIT 2

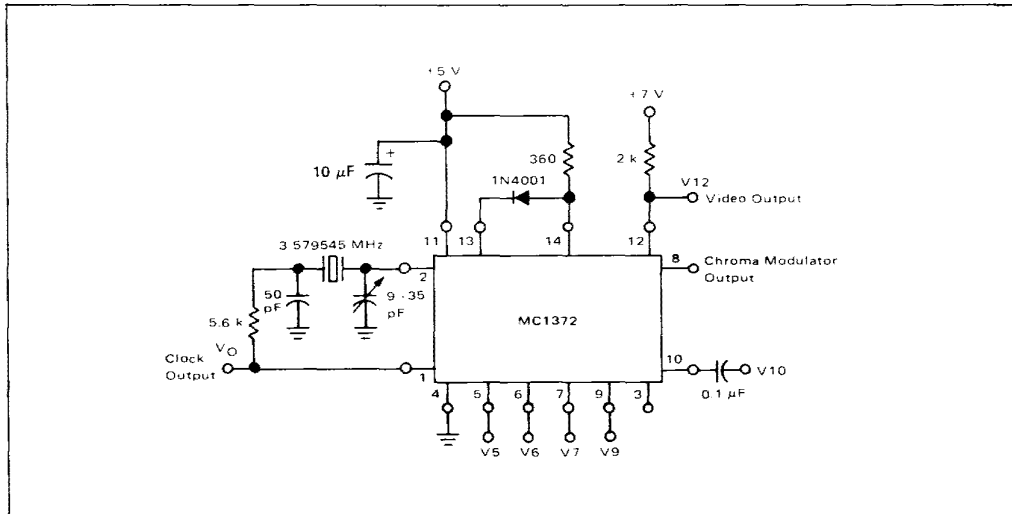
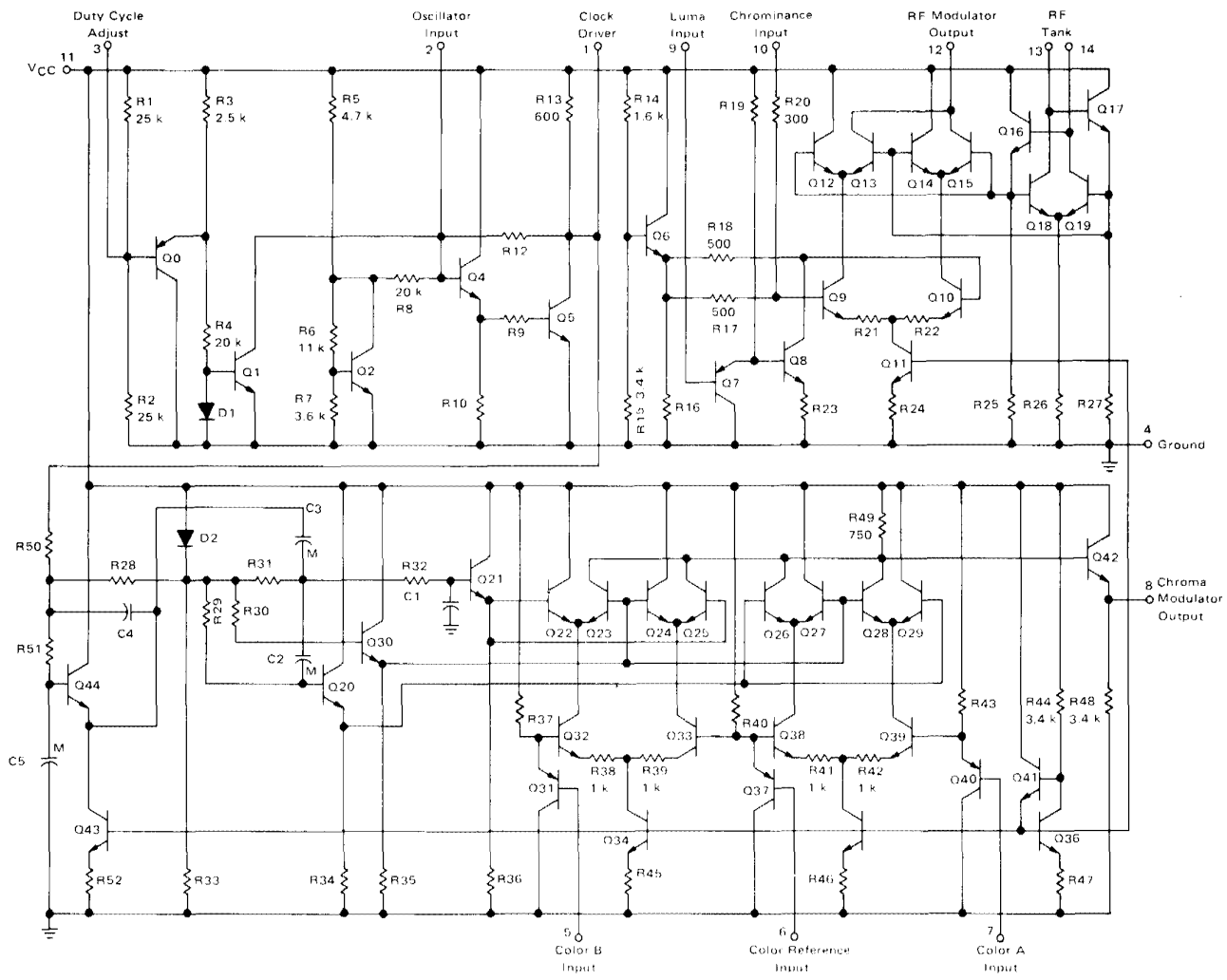

FIGURE 4 - SCHEMATIC DIAGRAM



## OPERATIONAL DESCRIPTION

### Pin 1 — Clock Output

Provides a rectangular pulse output waveform with frequency equal to the chrominance subcarrier oscillator. This output is capable of driving one LS-TTL load.

### Pin 2 — Oscillator Input

Color subcarrier oscillator feedback input. Signal from the clock output is externally phase shifted and ac coupled to this pin.

### Pin 3 — Duty Cycle Adjust

A dc voltage applied to this pin adjusts the duty cycle of the clock output signal. If the pin is left unconnected, the duty cycle is approximately 50%.

### Pin 4 — Ground

### Pin 5 — Color B Input

Dc coupled input to Chroma Modulator B, whose phase leads modulator A by approximately  $100^\circ$ . The modulator output amplitude and polarity correspond to the voltage difference between this pin and the Color Reference Voltage at Pin 6.

### Pin 6 — Color Reference Input

The dc voltage applied to this pin establishes the reference voltage to which Color A and Color B inputs are compared.

### Pin 7 — Color A Input

Dc coupled input to Chroma Modulator A, whose phase lags modulator B by approximately  $100^\circ$ . The modulator output amplitude and polarity correspond to the voltage difference between this pin and the Color Reference Voltage at Pin 6.

### Pin 8 — Chroma Modulator Output

Low impedance (emitter follower) output which provides the vectorial sum of chroma modulators A and B.

### Pin 9 — Luminance Input

Input to RF modulator. This pin accepts a dc coupled luminance and sync signal. The amplitude of the RF signal output increases with positive voltage applied to the pin, and ground potential results in zero output (i.e., 100% modulation). A signal with positive-going sync should be used.

### Pin 10 — Chrominance Input

Input to the RF modulator. This pin accepts ac coupled chrominance provided by the Chroma Modulator Output (pin 8). The signal is reduced by an internal resistor divider before being applied to the RF modulator. The resistor divider consists of a 300 ohm series resistor and a 500 ohm shunt resistor. Additional gain reduction may be obtained by the addition of external series resistance to pin 10.

### Pin 11 — VCC

Positive supply voltage

### Pin 12 — RF Modulator Output

Common collector of output modulator stage. Output impedance and stage gain may be selected by choice of resistor connected between this pin and dc supply.

### Pins 13 and 14 — RF Tank

A tuned circuit connected between these pins determines the RF oscillator frequency. The tuned circuit must provide a low dc resistance shunt. Applying a dc offset voltage between these pins results in baseband composite video at the RF Modulator Output.

## MC1372 CIRCUIT DESCRIPTION

The chrominance oscillator and clock driver consist of emitter follower Q4 and inverting amplifier Q5. Signal presented at clock driver output pin 1 is coupled to oscillator input pin 2 through an external RC and crystal network, which provides  $180^\circ$  phase shift at the resonant frequency. The duty cycle of the output waveform is determined by the dc component at pin 1 internally coupled through R12 to the base of Q4. As pin 1 dc voltage increases, a smaller portion of the sinusoidal feedback signal at pin 2 exceeds the Q4 base voltage of two times  $V_{BE}$  required for conduction. As the dc level is reduced, device Q4 and thus Q5 is turned on for a longer percentage of the cycle. Transistors Q0, Q1, Q2 and diode D1 provide the biasing network which determines the dc operating level of the oscillator. The transistor Q2 and resistors R5, R6, and R7 form a voltage reference of four times  $V_{BE}$  at the collector of Q2. The dc voltage at pin 1 is determined by the values of R4, R8, and R12 and the applied duty cycle adjust voltage at pin 3. Since these resistors are nominally equal, the voltage at pin 1 will always approximate the dc voltage at pin 3.

The oscillator signal at pin 1 is internally coupled to active filter Q44. This filter reduces the frequency content above 4 MHz. The output of the filter at the emitter of Q44 is ac coupled through C3 to the input of the lead/lag network. R32 and C1 provide approximately  $50^\circ$  of phase lag, while C2 and R29 provide approximately  $50^\circ$  of phase lead. These two quasi-quadrature waveforms are used to switch chroma modulators B and A, respectively. The transistors Q22 through Q25 and Q32–Q33 form a doubly balanced modulator. The input signal applied at pin 5 is compared to the color dc reference voltage applied at pin 6 in differential amplifier Q32–Q33. The source current provided by transistor Q34 is partitioned in transistors Q32 and Q33 according to the differential input signal. The bases of transistors Q23 and Q24 are connected to the dc reference voltage at the emitter of Q30. The bases of transistors Q22 and Q25 are connected

to the phase delayed oscillator signal at the emitter of buffer transistor Q21. The differential signal currents provided by Q32 and Q33 are switched in transistors Q22 through Q25 and the resultant signal voltage is developed across R49. This signal has the phase and frequency of the oscillator signal at the emitter of Q21. The amplitude is proportional to the differential input signal applied between pins 5 and 6. Transistors Q26 through Q29 and Q38–Q39 form chroma modulator B. This modulator develops a signal voltage which is proportional to the differential voltage applied between pins 7 and 6. The phase and frequency of the output is equal to the phase advanced chroma oscillator at the emitter of buffer transistor Q20. Both chroma modulators A and B share the same output resistor, R49, so the output signal presented at the emitter of Q42 (pin 8) is the algebraic sum of modulators A and B.

The RF oscillator consists of differential amplifier Q18 and Q19 cross-coupled through emitter followers Q16 and Q17. The oscillator will operate at the parallel resonant frequency of the network connected between pins 13 and 14. The oscillator output is used to switch the doubly balanced RF modulator, Q9 through Q15. Transistors Q7 and Q8 provide level shifting and a high input impedance to the luminance input pin 9. The bases of transistors Q9 and Q10 are both biased through resistors R17 and R18, respectively, to the same dc reference voltage at Q6 emitter. The base voltage at Q10 may only be offset in a negative direction by luminance signal current source Q8. This design insures that over-modulation due to the luminance signal will never occur. The chrominance signal developed at pin 8 is externally ac coupled to pin 10 where it is reduced by resistor dividers R20 and R17, and added to the luminance signal in Q9. The resultant differential composite video currents are switched at the appropriate RF frequency in Q12 through Q15. The output signal current is presented at pin 12.

Transistors Q36, Q41 and resistors R44, R47 provide a highly stable voltage reference for biasing current sources Q43, Q34, Q35, and Q11.

## MC1372 APPLICATION INFORMATION

### Chrominance Oscillator

The oscillator is used as a clock signal for driving associated external circuitry, in addition to providing a switching signal for the chroma modulators. The IC uses an external crystal in a Colpitts configuration, as shown in Figure 5. Resistor R1 provides current limiting to reduce the signal swing. Capacitor C2 is adjusted for the exact frequency desired (3.579545 MHz).

In some applications, the duty cycle of the clock signal at pin 1 must be modified to overcome gate delays in

associated equipment. The duty cycle may be adjusted by varying the dc voltage applied to pin 3. This adjustment may be made with the use of a potentiometer (10 k $\Omega$ ) between supply and ground. With no connection to pin 3, the duty cycle is approximately 50%.

### Chroma Modulator

The chrominance oscillator is internally phase shifted and applied to chroma modulators A and B. No external lead/lag networks are necessary. The phase relationship between the modulators is approximately 100 $^{\circ}$ , which was chosen to provide the best rendition of colors using equal amplitude color-difference signals. The voltage applied to pin 5, 6, or 7 must always be within the Input Common Mode Voltage Range. Since the amplitude of chrominance output is proportional to the voltage difference between pins 5 and 6 or 7 and 6, it is desirable to select the Color Reference Voltage applied to pin 6 to be midway between  $V_{5\max}$  and  $V_{5\min}$  (which should be  $V_{7\max}$  and  $V_{7\min}$ ). The Chroma B Modulator will be defined as a (B-Y) modulator if a burst flag signal is applied to the Color B Input (pin 5) at the appropriate time. This voltage should be negative with respect to the Color Reference Voltage, and typically has an amplitude equal to  $1/2[V_6 - V_{5\min}]$ . Since the phase of burst is always defined as -(B-Y), the Chroma A Modulator approximates an (R-Y) modulator; however, the phase is offset by 10 $^{\circ}$  from the nominal 90 $^{\circ}$ , to provide the 100 $^{\circ}$  phase shift as discussed previously.

### RF Modulator and Oscillator

The coil and capacitor connected between pins 13 and 14 should be selected to have a parallel resonance at the carrier frequency of the desired TV channel. The values of 56 pF and 0.1  $\mu$ H shown in Figure 5 were chosen for a Channel 4 carrier frequency of 67.25 MHz. For Channel 3 operation, the resonant frequency should be 61.25 MHz ( $C = 75$  pF,  $L = 0.1$   $\mu$ H). Resistors R4 and R5 are chosen to provide an adequate amplitude of switching voltage, whereas R6 is used to lower the maximum dc level of switching voltage below  $V_{CC}$ , thus preventing saturation within the IC.

Composite Luminance and Sync should be dc coupled to Luminance Input, pin 9. This signal must be within the Luma Input Dynamic Range to insure linearity. Since an increase in dc voltage applied to pin 9 results in an increase in RF output, the input signal should have positive-going sync to generate an NTSC compatible signal. As long as the input signal is positive, over-modulation is prevented by the integrated circuit.

Chrominance information should be ac coupled to Chrominance Input, pin 10. This pin is internally connected to a resistor divider consisting of a series 300 ohms and a shunt 500 ohms resistor. The input impedance is thus 800 ohms, and a coupling capacitor should be appropriately chosen.

FIGURE 5 – TYPICAL APPLICATION CIRCUIT

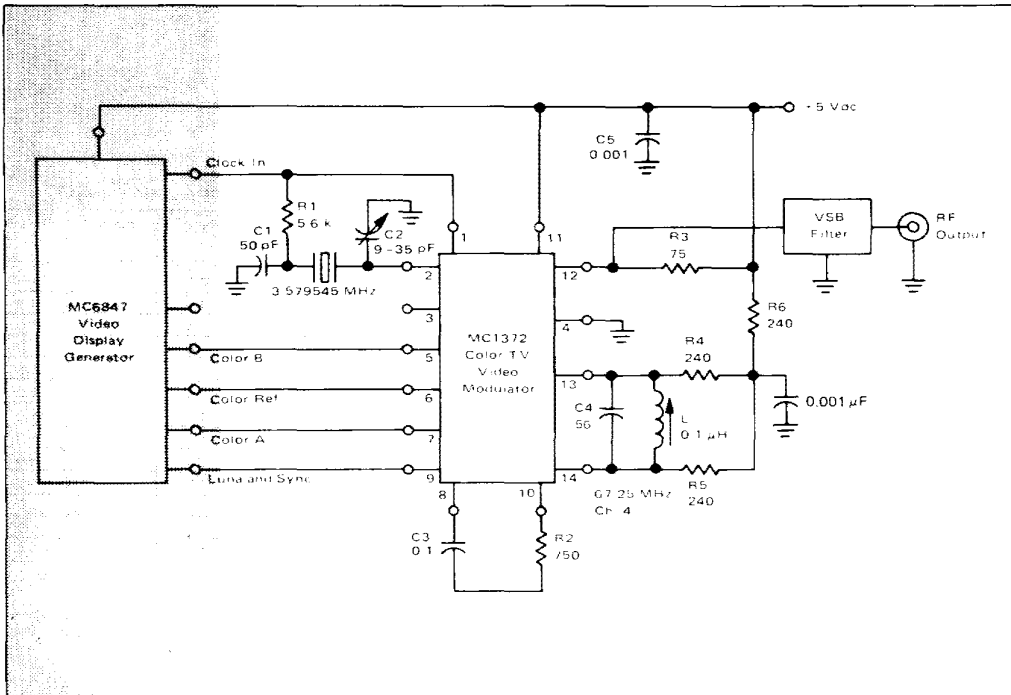

The Luminance to Chrominance ratio (L:C) may be modified with the addition of an external resistor in series with pin 10 (as shown in Figure 5). The unmodified L:C ( $A_0$ ) is determined by the ratio of the respective Conversion Gain for equal amplitude signals (typically,  $0.883 = -1.6$  dB). The modified L:C will be governed by the equation  $A_0(1 + R_{ext}/800)$  for equal amplitude input signals.

The internal chrominance modulators are not internally connected to the RF modulator; therefore, the user has the option of connecting an externally generated chrominance signal to the RF modulator. In addition, the RF modulator is wideband, and a 4.5 MHz FM audio signal may be added to the chrominance input at pin 10. This may be accomplished by selecting an appropriate series input resistor to provide the correct Luminance:Sound ratio.

The modulated RF signal is presented as a current at RF Modulator Output, pin 12. Since this pin represents a current source, any load impedance may be selected for matching purposes and gain selection, as long as the vol-

tage at pin 12 is high enough to prevent the output devices from reaching saturation (approximately 4.5 V with components in Figure 5). The peak current out of pin 12 is typically 2 mA. Hence, a load resistance of up to 250 ohms may be safely used with a 5 V supply.

#### Composite Video Signal Generation

The RF modulator may be easily used as a composite video generator by replacing the RF oscillator tank circuit with a diode as shown in Figure 3. This results in the output modulator being biased so the summation of luminance and chrominance appears unswitched at pin 12. The polarity of the output waveform is controlled by the direction of the diode. *Inverted video*: Anode to pin 14, cathode to pin 13. *Non-inverted video*: Anode to pin 13, cathode to pin 14. Note that the supply resistor must always be connected to the anode of the diode.

The amplitude of signal may be increased by increasing the load resistor on pin 12 and returning it to a higher supply voltage. Any voltage up to the Absolute Maximum Rating may be used.

### Applications with MC6847 Video Display Generator

The MC1372 may be easily interfaced to the MC6847 as shown in Figure 5. The dc levels generated and required by the VDG are compatible with the MC1372, so that pins 1, 5, 6, 7, and 9 may be directly coupled to the appropriate MC6847 pins. Both integrated circuits as well as any associated NMOS MPU may be driven from a common 5 Vdc supply.

### Recommended Chroma-Luma Signals

A chroma modulation angle of  $100^\circ$  was chosen to facilitate a desirable selection of colors with a minimum number of input signal levels. The following table demonstrates applicable signal levels for a variety of colors.

RECOMMENDED CHROMA-LUMA SIGNALS

	Pin #9 Luminance Input (Vdc)	Pin #7 Color A (Vdc)	Pin #6 Color Ref. (Vdc)	Pin #5 Color B (Vdc)
Sync	1.0	1.5	1.5	1.5
Blanking	0.75	1.5	1.5	1.5
Burst	0.75	1.5	1.5	1.25
Black	0.70	1.5	1.5	1.5
Green	0.50	1.0	1.5	1.0
Yellow	0.38	1.5	1.5	1.0
Blue	0.62	1.5	1.5	2.0
Red	0.62	2.0	1.5	1.5
Cyan	0.50	1.0	1.5	1.5
Magenta	0.50	2.0	1.5	2.0
Orange	0.50	2.0	1.5	1.0
Buff	0.38	1.5	1.5	1.5