

# MOTOROLA

## SEMICONDUCTOR TECHNICAL DATA

### MC14517B

## Dual 64-Bit Static Shift Register

The MC14517B dual 64-bit static shift register consists of two identical, independent, 64-bit registers. Each register has separate clock and write enable inputs, as well as outputs at bits 16, 32, 48, and 64. Data at the data input is entered by clocking, regardless of the state of the write enable input. An output is disabled (open circuited) when the write enable input is high. During this time, data appearing at the data input as well as the 16-bit, 32-bit, and 48-bit taps may be entered into the device by application of a clock pulse. This feature permits the register to be loaded with 64 bits in 16 clock periods, and also permits bus logic to be used. This device is useful in time delay circuits, temporary memory storage circuits, and other serial shift register applications.

- Diode Protection on All Inputs
- Fully Static Operation
- Output Transitions Occur on the Rising Edge of the Clock Pulse
- Exceedingly Slow Input Transition Rates May Be Applied to the Clock Input
- 3-State Output at 64th-Bit Allows Use in Bus Logic Applications
- Shift Registers of any Length may be Fully Loaded with 16 Clock Pulses
- Supply Voltage Range = 3.0 Vdc to 18 Vdc
- Capable of Driving Two Low-power TTL Loads or One Low-power Schottky TTL Load Over the Rated Temperature Range

### MAXIMUM RATINGS (Voltages referenced to $V_{SS}$ )

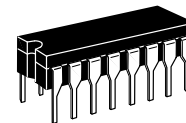
Symbol	Parameter	Value	Unit
$V_{DD}$	DC Supply Voltage	- 0.5 to + 18.0	V
$V_{in}, V_{out}$	Input or Output Voltage (DC or Transient)	- 0.5 to $V_{DD} + 0.5$	V
$I_{in}, I_{out}$	Input or Output Current (DC or Transient), per Pin	$\pm 10$	mA
$P_D$	Power Dissipation, per Package†	500	mW
$T_{stg}$	Storage Temperature	- 65 to + 150	°C
$T_L$	Lead Temperature (8-Second Soldering)	260	°C

\* Maximum Ratings are those values beyond which damage to the device may occur.

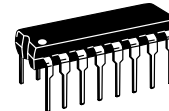
† Temperature Derating:

Plastic "P and D/DW" Packages: - 7.0 mW/°C From 65°C To 125°C

Ceramic "L" Packages: - 12 mW/°C From 100°C To 125°C



**L SUFFIX**  
CERAMIC  
CASE 620



**P SUFFIX**  
PLASTIC  
CASE 648



**DW SUFFIX**  
SOIC  
CASE 751G

### ORDERING INFORMATION

MC14XXXBCP	Plastic
MC14XXXBCL	Ceramic
MC14XXXBDW	SOIC

$T_A = -55^\circ$  to  $125^\circ\text{C}$  for all packages.

### PIN ASSIGNMENT

Q16A	1	16	$V_{DD}$
Q48A	2	15	Q16B
WEA	3	14	Q48B
CA	4	13	WE <sub>B</sub>
Q64A	5	12	C <sub>B</sub>
Q32A	6	11	Q64B
DA	7	10	Q32B
$V_{SS}$	8	9	D <sub>B</sub>

### FUNCTIONAL TRUTH TABLE (X = Don't Care)

Clock	Write Enable	Data	16-Bit Tap	32-Bit Tap	48-Bit Tap	64-Bit Tap
0	0	X	Content of 16-Bit Displayed	Content of 32-Bit Displayed	Content of 48-Bit Displayed	Content of 64-Bit Displayed
0	1	X	High Impedance	High Impedance	High Impedance	High Impedance
1	0	X	Content of 16-Bit Displayed	Content of 32-Bit Displayed	Content of 48-Bit Displayed	Content of 64-Bit Displayed
1	1	X	High Impedance	High Impedance	High Impedance	High Impedance
↗	0	Data entered into 1st Bit	Content of 16-Bit Displayed	Content of 32-Bit Displayed	Content of 48-Bit Displayed	Content of 64-Bit Displayed
↗	1	Data entered into 1st Bit	Data at tap entered into 17-Bit	Data at tap entered into 33-Bit	Data at tap entered into 49-Bit	High Impedance
↘	0	X	Content of 16-Bit Displayed	Content of 32-Bit Displayed	Content of 48-Bit Displayed	Content of 64-Bit Displayed
↘	1	X	High Impedance	High Impedance	High Impedance	High Impedance



**ELECTRICAL CHARACTERISTICS** (Voltages Referenced to  $V_{SS}$ )

Characteristic	Symbol	$V_{DD}$ Vdc	-55° C		25° C			125° C		Unit	
			Min	Max	Min	Typ #	Max	Min	Max		
Output Voltage $V_{in} = V_{DD}$ or 0  $V_{in} = 0$ or $V_{DD}$	"0" Level  $V_{OL}$	5.0	—	0.05	—	0	0.05	—	0.05	Vdc	
		10	—	0.05	—	0	0.05	—	0.05		
		15	—	0.05	—	0	0.05	—	0.05		
	"1" Level  $V_{OH}$	5.0	4.95	—	4.95	5.0	—	4.95	—		Vdc
		10	9.95	—	9.95	10	—	9.95	—		
		15	14.95	—	14.95	15	—	14.95	—		
Input Voltage "0" Level ( $V_O = 4.5$ or $0.5$ Vdc) ( $V_O = 9.0$ or $1.0$ Vdc) ( $V_O = 13.5$ or $1.5$ Vdc)  "1" Level ( $V_O = 0.5$ or $4.5$ Vdc) ( $V_O = 1.0$ or $9.0$ Vdc) ( $V_O = 1.5$ or $13.5$ Vdc)	$V_{IL}$	5.0	—	1.5	—	2.25	1.5	—	1.5	Vdc	
		10	—	3.0	—	4.50	3.0	—	3.0		
		15	—	4.0	—	6.75	4.0	—	4.0		
	$V_{IH}$	5.0	3.5	—	3.5	2.75	—	3.5	—		Vdc
		10	7.0	—	7.0	5.50	—	7.0	—		
		15	11	—	11	8.25	—	11	—		
Output Drive Current Source ( $V_{OH} = 2.5$ Vdc) ( $V_{OH} = 4.6$ Vdc) ( $V_{OH} = 9.5$ Vdc) ( $V_{OH} = 13.5$ Vdc)  Sink ( $V_{OL} = 0.4$ Vdc) ( $V_{OL} = 0.5$ Vdc) ( $V_{OL} = 1.5$ Vdc)	$I_{OH}$	5.0	-3.0	—	-2.4	-4.2	—	-1.7	—	mAdc	
		5.0	-0.64	—	-0.51	-0.88	—	-0.36	—		
		10	-1.6	—	-1.3	-2.25	—	-0.9	—		
		15	-4.2	—	-3.4	-8.8	—	-2.4	—		
	$I_{OL}$	5.0	0.64	—	0.51	0.88	—	0.36	—		mAdc
		10	1.6	—	1.3	2.25	—	0.9	—		
15		4.2	—	3.4	8.8	—	2.4	—			
Input Current	$I_{in}$	15	—	$\pm 0.1$	—	$\pm 0.00001$	$\pm 0.1$	—	$\pm 1.0$	$\mu$ Adc	
Input Capacitance ( $V_{in} = 0$ )	$C_{in}$	—	—	—	—	5.0	7.5	—	—	pF	
Quiescent Current (Per Package)	$I_{DD}$	5.0 10 15	— — —	5.0 10 20	— — —	0.005 0.010 0.015	5.0 10 20	— — —	150 300 600	$\mu$ Adc	
Total Supply Current**† (Dynamic plus Quiescent, Per Package) ( $C_L = 50$ pF on all outputs, all buffers switching)	$I_T$	5.0 10 15	$I_T = (4.2 \mu\text{A/kHz}) f + I_{DD}$ $I_T = (8.8 \mu\text{A/kHz}) f + I_{DD}$ $I_T = (13.7 \mu\text{A/kHz}) f + I_{DD}$							$\mu$ Adc	
Three-State Leakage Current	$I_{TL}$	15	—	$\pm 0.1$	—	$\pm 0.0001$	$\pm 0.1$	—	$\pm 3.0$	$\mu$ Adc	

#Data labelled "Typ" is not to be used for design purposes but is intended as an indication of the IC's potential performance.

\*\*The formulas given are for the typical characteristics only at 25° C.

†To calculate total supply current at loads other than 50 pF:

$$I_T(C_L) = I_T(50 \text{ pF}) + (C_L - 50) Vfk$$

where:  $I_T$  is in  $\mu\text{A}$  (per package),  $C_L$  in pF,  $V = (V_{DD} - V_{SS})$  in volts,  $f$  in kHz is input frequency, and  $k = 0.004$ .

This device contains protection circuitry to guard against damage due to high static voltages or electric fields. However, precautions must be taken to avoid applications of any voltage higher than maximum rated voltages to this high-impedance circuit. For proper operation,  $V_{in}$  and  $V_{out}$  should be constrained to the range  $V_{SS} \leq (V_{in} \text{ or } V_{out}) \leq V_{DD}$ . Unused inputs must always be tied to an appropriate logic voltage level (e.g., either  $V_{SS}$  or  $V_{DD}$ ). Unused outputs must be left open.

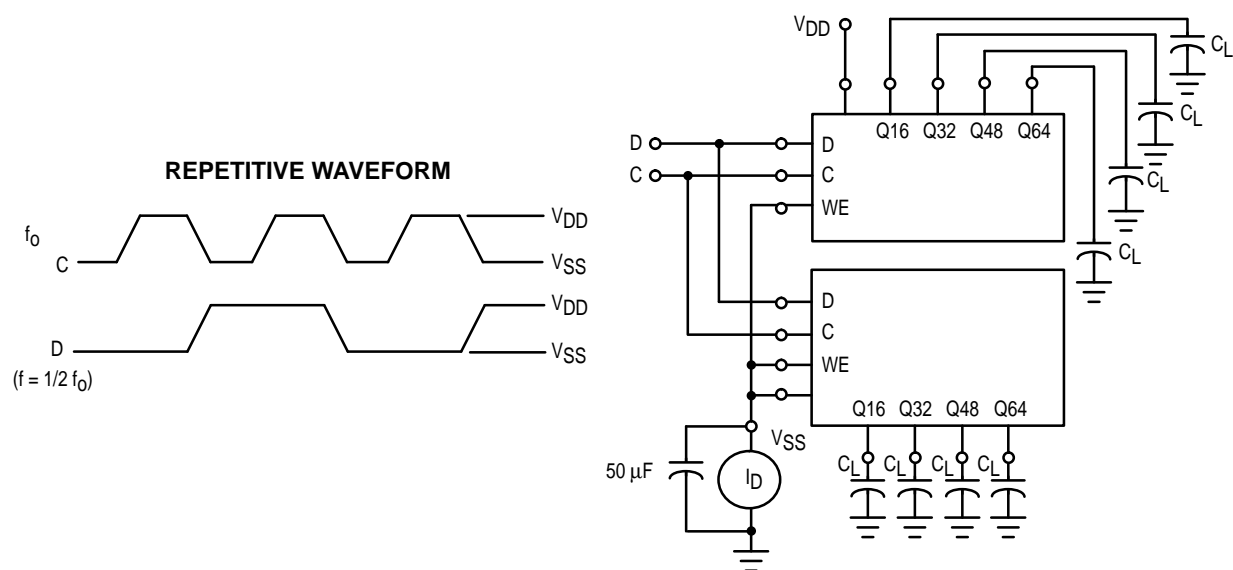
**SWITCHING CHARACTERISTICS\*** ( $C_L = 50 \text{ pF}$ ,  $T_A = 25^\circ \text{C}$ )

Characteristic	Symbol	$V_{DD}$	Min	Typ #	Max	Unit
Output Rise and Fall Time $t_{TLH}$ , $t_{THL} = (1.5 \text{ ns/pF}) C_L + 25 \text{ ns}$ $t_{TLH}$ , $t_{THL} = (0.75 \text{ ns/pF}) C_L + 12.5 \text{ ns}$ $t_{TLH}$ , $t_{THL} = (0.65 \text{ ns/pF}) C_L + 9.5 \text{ ns}$	$t_{TLH}$ , $t_{THL}$	5.0 10 15	— — —	100 50 40	200 100 80	ns
Propagation Delay Time $t_{PLH}$ , $t_{PHL} = (1.7 \text{ ns/pF}) C_L + 390 \text{ ns}$ $t_{PLH}$ , $t_{PHL} = (0.66 \text{ ns/pF}) C_L + 177 \text{ ns}$ $t_{PLH}$ , $t_{PHL} = (0.5 \text{ ns/pF}) C_L + 115 \text{ ns}$	$t_{PLH}$ , $t_{PHL}$	5.0 10 15	— — —	475 210 140	770 300 215	ns
Clock Pulse Width	$t_{WH}$	5.0 10 15	330 125 100	170 75 60	— — —	ns
Clock Pulse Frequency	$f_{cl}$	5.0 10 15	— — —	3.0 6.7 8.3	1.5 4.0 5.3	MHz
Clock Pulse Rise and Fall Time	$t_{TLH}$ , $t_{THL}$	5.0 10 15	**See Note			—
Data to Clock Setup Time	$t_{su}$	5.0 10 15	0 10 15	-40 -15 0	— — —	ns
Data to Clock Hold Time	$t_h$	5.0 10 15	150 75 35	75 25 10	— — —	ns
Write Enable to Clock Setup Time	$t_{su}$	5.0 10 15	400 200 110	170 65 50	— — —	ns
Write Enable to Clock Release Time	$t_{rel}$	5.0 10 15	380 180 100	160 55 40	— — —	ns

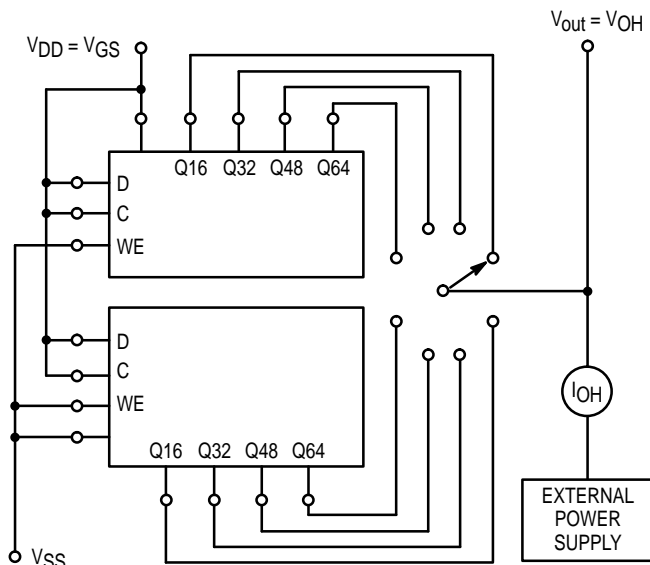
\* The formulas given are for the typical characteristics only at  $25^\circ \text{C}$ .

# Data labelled "Typ" is not to be used for design purposes but is intended as an indication of the IC's potential performance.

\*\* When shift register sections are cascaded, the maximum rise and fall time of the clock input should be equal to or less than the rise and fall time of the data outputs, driving data inputs, plus the propagation delay of the output driving stage.

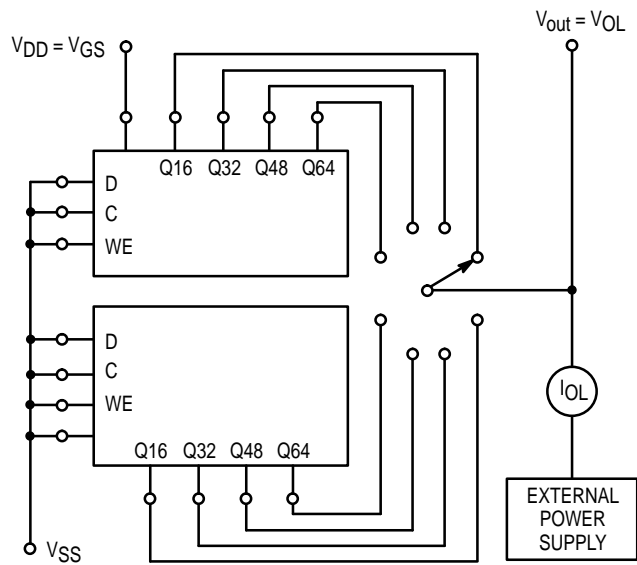


**Figure 1. Power Dissipation Test Circuit and Waveform**



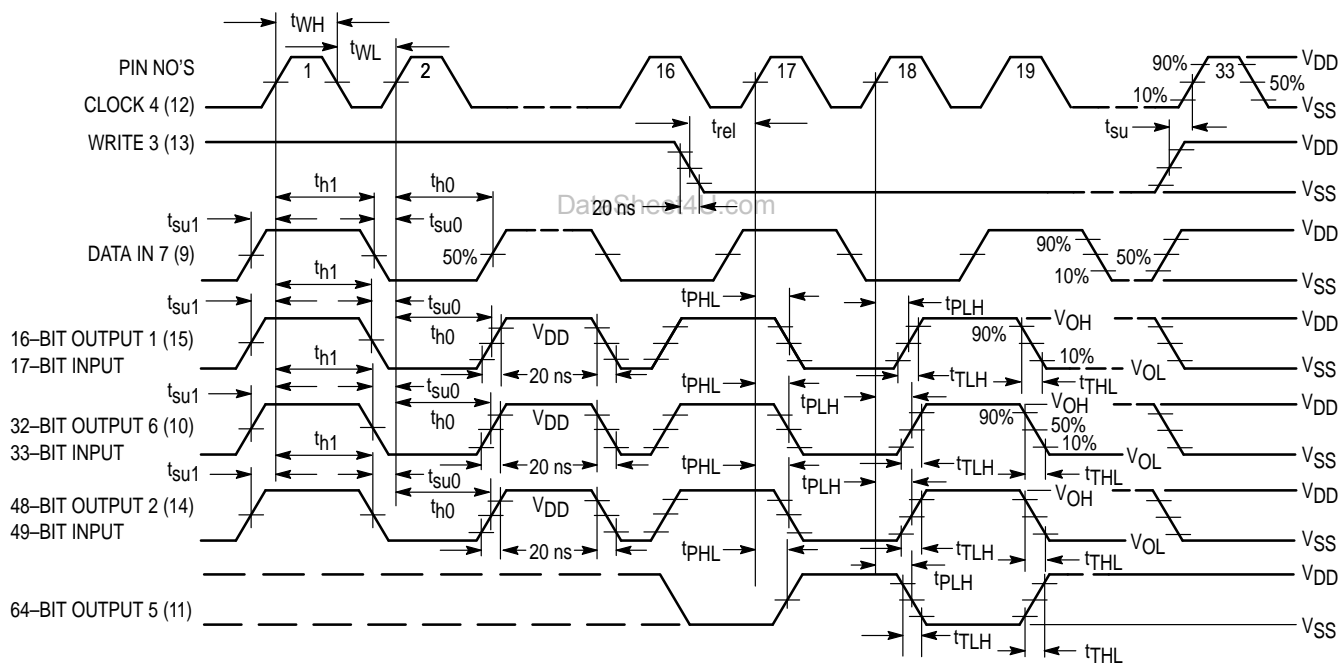
(Output being tested should be in the high-logic state)

**Figure 2. Typical Output Source Current Characteristics Test Circuit**



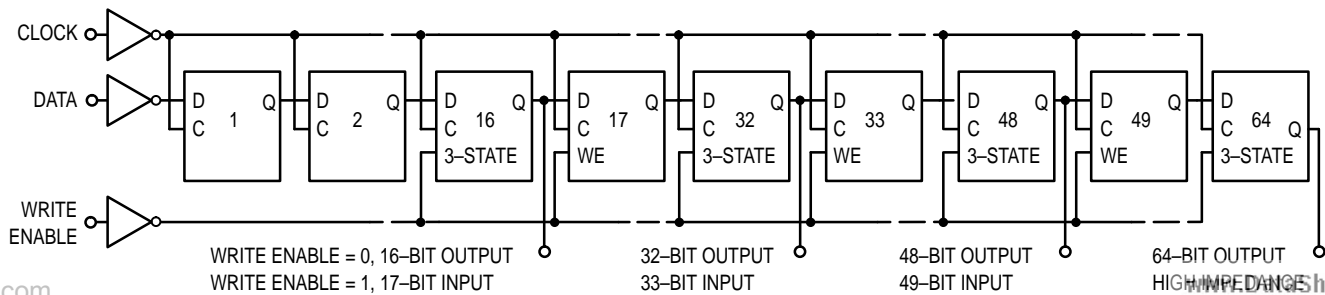
(Output being tested should be in the low-logic state)

**Figure 3. Typical Output Sink Current Characteristics Test Circuit**



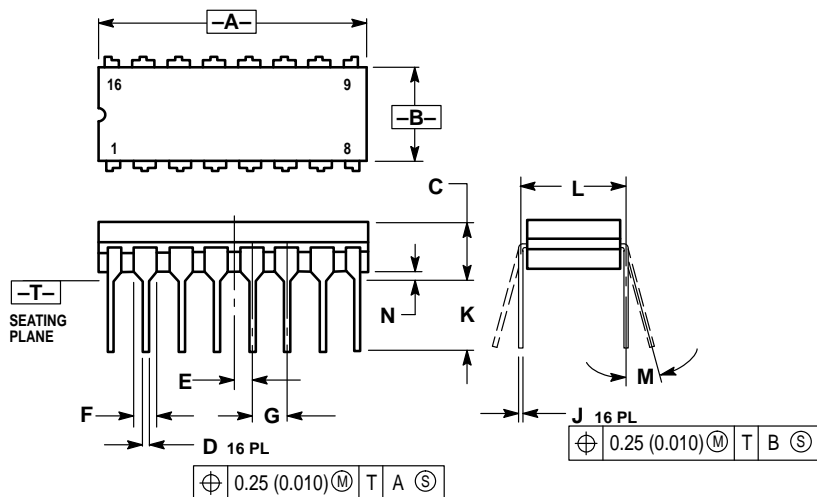
**Figure 4. AC Test Waveforms**

**EXPANDED BLOCK DIAGRAM (1/2 OF DEVICE SHOWN)**



### OUTLINE DIMENSIONS

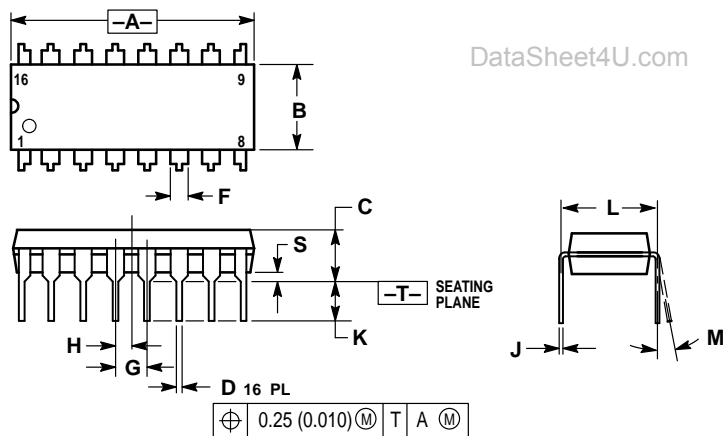
#### L SUFFIX CERAMIC DIP PACKAGE CASE 620-10 ISSUE V



- NOTES:
1. DIMENSIONING AND TOLERANCING PER ANSI Y14.5M, 1982.
  2. CONTROLLING DIMENSION: INCH.
  3. DIMENSION L TO CENTER OF LEAD WHEN FORMED PARALLEL.
  4. DIMENSION F MAY NARROW TO 0.76 (0.030) WHERE THE LEAD ENTERS THE CERAMIC BODY.

DIM	INCHES		MILLIMETERS	
	MIN	MAX	MIN	MAX
A	0.750	0.785	19.05	19.93
B	0.240	0.295	6.10	7.49
C	—	0.200	—	5.08
D	0.015	0.020	0.39	0.50
E	0.050 BSC		1.27 BSC	
F	0.055	0.065	1.40	1.65
G	0.100 BSC		2.54 BSC	
H	0.008	0.015	0.21	0.38
K	0.125	0.170	3.18	4.31
L	0.300 BSC		7.62 BSC	
M	0°	15°	0°	15°
N	0.020	0.040	0.51	1.01

#### P SUFFIX PLASTIC DIP PACKAGE CASE 648-08 ISSUE R



- NOTES:
1. DIMENSIONING AND TOLERANCING PER ANSI Y14.5M, 1982.
  2. CONTROLLING DIMENSION: INCH.
  3. DIMENSION L TO CENTER OF LEADS WHEN FORMED PARALLEL.
  4. DIMENSION B DOES NOT INCLUDE MOLD FLASH.
  5. ROUNDED CORNERS OPTIONAL.

DIM	INCHES		MILLIMETERS	
	MIN	MAX	MIN	MAX
A	0.740	0.770	18.80	19.55
B	0.250	0.270	6.35	6.85
C	0.145	0.175	3.69	4.44
D	0.015	0.021	0.39	0.53
F	0.040	0.70	1.02	1.77
G	0.100 BSC		2.54 BSC	
H	0.050 BSC		1.27 BSC	
J	0.008	0.015	0.21	0.38
K	0.110	0.130	2.80	3.30
L	0.295	0.305	7.50	7.74
M	0°	10°	0°	10°
S	0.020	0.040	0.51	1.01

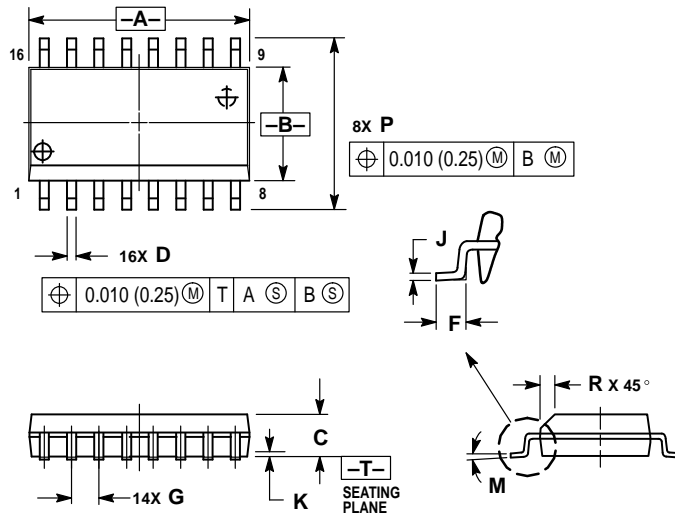
et4U.com

DataSheet4U.com

DataShee

## OUTLINE DIMENSIONS

### DW SUFFIX PLASTIC SOIC PACKAGE CASE 751G-02 ISSUE A



#### NOTES:

1. DIMENSIONING AND TOLERANCING PER ANSI Y14.5M, 1982.
2. CONTROLLING DIMENSION: MILLIMETER.
3. DIMENSIONS A AND B DO NOT INCLUDE MOLD PROTRUSION.
4. MAXIMUM MOLD PROTRUSION 0.15 (0.006) PER SIDE.
5. DIMENSION D DOES NOT INCLUDE DAMBAR PROTRUSION. ALLOWABLE DAMBAR PROTRUSION SHALL BE 0.13 (0.005) TOTAL IN EXCESS OF D DIMENSION AT MAXIMUM MATERIAL CONDITION.

DIM	MILLIMETERS		INCHES	
	MIN	MAX	MIN	MAX
A	10.15	10.45	0.400	0.411
B	7.40	7.60	0.292	0.299
C	2.35	2.65	0.093	0.104
D	0.35	0.49	0.014	0.019
F	0.50	0.90	0.020	0.035
G	1.27 BSC		0.050 BSC	
J	0.25	0.32	0.010	0.012
K	0.10	0.25	0.004	0.009
M	0°	7°	0°	7°
P	10.05	10.55	0.395	0.415
R	0.25	0.75	0.010	0.029

DataSheet4U.com

Motorola reserves the right to make changes without further notice to any products herein. Motorola makes no warranty, representation or guarantee regarding the suitability of its products for any particular purpose, nor does Motorola assume any liability arising out of the application or use of any product or circuit, and specifically disclaims any and all liability, including without limitation consequential or incidental damages. "Typical" parameters which may be provided in Motorola data sheets and/or specifications can and do vary in different applications and actual performance may vary over time. All operating parameters, including "Typicals" must be validated for each customer application by customer's technical experts. Motorola does not convey any license under its patent rights nor the rights of others. Motorola products are not designed, intended, or authorized for use as components in systems intended for surgical implant into the body, or other applications intended to support or sustain life, or for any other application in which the failure of the Motorola product could create a situation where personal injury or death may occur. Should Buyer purchase or use Motorola products for any such unintended or unauthorized application, Buyer shall indemnify and hold Motorola and its officers, employees, subsidiaries, affiliates, and distributors harmless against all claims, costs, damages, and expenses, and reasonable attorney fees arising out of, directly or indirectly, any claim of personal injury or death associated with such unintended or unauthorized use, even if such claim alleges that Motorola was negligent regarding the design or manufacture of the part. Motorola and are registered trademarks of Motorola, Inc. Motorola, Inc. is an Equal Opportunity/Affirmative Action Employer.

#### How to reach us:

**USA/EUROPE/Locations Not Listed:** Motorola Literature Distribution;  
P.O. Box 20912; Phoenix, Arizona 85036. 1-800-441-2447 or 602-303-5454

**MFAX:** RMFAX0@email.sps.mot.com – TOUCHTONE 602-244-6609  
**INTERNET:** <http://Design-NET.com>

**JAPAN:** Nippon Motorola Ltd.; Tatsumi-SPD-JLDC, 6F Seibu-Butsuryu-Center,  
3-14-2 Tatsumi Koto-Ku, Tokyo 135, Japan. 03-81-3521-8315

**ASIA/PACIFIC:** Motorola Semiconductors H.K. Ltd.; 8B Tai Ping Industrial Park,  
51 Ting Kok Road, Tai Po, N.T., Hong Kong. 852-26629298



MC14517B/D

