

GENERAL DESCRIPTION

The MC3253 is a low-noise, integrated digital output 3-axis accelerometer with a feature set optimized for cell phones and consumer product motion sensing. Applications include user interface control, gaming motion input, electronic compass tilt compensation for cell phones, game controllers, remote controls and portable media products.

Accurate event detection is enabled with a low noise architecture that minimizes false triggering found in competing devices. Low noise and low power are inherent in the monolithic fabrication approach, where the MEMS accelerometer is integrated in a single-chip with the electronics integrated circuit.

In the MC3253 the internal sample rate is fixed at 1024 samples / second. Specific orientation and gesture conditions can trigger an interrupt to a remote MCU. Alternatively, the device supports the reading of sample and event status via polling.

FEATURES

Range, Sampling & Power

- $\pm 2g$ / $\pm 4g$ / $\pm 8g$ ranges
- 10-bit or 14-bit resolution
- 1024 samples/sec
- Programmable low pass filter
 - From 8 to 512 Hz bandwidth

Event Detection

- Low-noise architecture minimizes false triggering
- Tap, Shake, Drop
- Portrait or landscape orientation with programmable hysteresis
- Tilt detection in six orientations

Simple System Integration

- I2C interface, up to 400 kHz
- $3 \times 3 \times 0.92$ mm 16-pin package
 - Pin-compatible to MMA845x, ADXL346, LIS3DH, KXCJK, KXTIK accelerometers
- Single-chip 3D silicon MEMS
- $100\mu g / \sqrt{Hz}$ noise

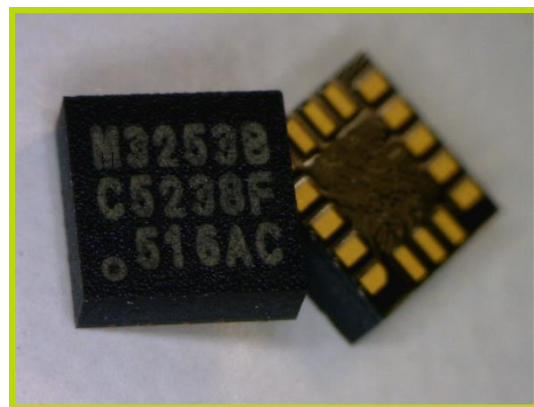

TABLE OF CONTENTS

- 1 Order Information..... 5
- 2 Functional Block Diagram 6
- 3 Packaging and Pin Description 7
 - 3.1 Package Outline..... 7
 - 3.2 Pin Description..... 8
 - 3.3 Typical Application Circuit 9
- 4 Specifications..... 10
 - 4.1 Absolute Maximum Ratings..... 10
 - 4.2 Sensor Characteristics 11
 - 4.3 Electrical and Timing Characteristics..... 12
 - 4.3.1 Electrical Power and Internal Characteristics..... 12
 - 4.3.2 I2C Electrical Characteristics 13
 - 4.3.3 I2C Timing Characteristics 14
- 5 General Operation 15
 - 5.1 Sensor Sampling..... 15
 - 5.2 Offset and Gain Calibration 16
- 6 Operational States 17
- 7 Operational State Flow 18
- 8 Interrupts..... 19
 - 8.1 Enabling and Clearing Interrupts 19
 - 8.2 Interrupt Support 20
 - 8.3 GINT Interrupt..... 21
 - 8.4 Event Detection..... 22
- 9 Orientation Detection 23
 - 9.1 Orientation Hysteresis..... 23
 - 9.2 Portrait/Landscape Events 23
 - 9.3 Front/Back Events..... 28
 - 9.4 Shake Detection..... 30
 - 9.5 Drop Detection 32
 - 9.6 Tap Detection..... 33
 - 9.7 Continuous Sampling 35
- 10 I2C Interface 36



10.1	Physical Interface.....	36
10.2	Timing.....	36
10.3	I2C Message Format.....	36
11	Register Interface	38
11.1	Register Summary	39
11.2	TILT: Status Register	41
11.3	OPSTAT: Operational State Status Register.....	43
11.4	INTEN: Interrupt Enable Register.....	44
11.5	MODE: Register.....	45
11.6	TAPEN: Tap Detection Enable Register.....	46
11.7	TAPP: Tap Pulse Register	47
11.8	DROP: Drop Event Control Register	48
11.9	SHDB: Shake Debounce Register.....	49
11.10	XOUT_EX, YOUT_EX & ZOUT_EX: X, Y, Z-Axis Extended Accelerometer Registers	50
11.11	OUTCFG: Output Configuration Register	51
11.12	X-Axis Offset Registers	52
11.13	Y-Axis Offset Registers	53
11.14	Z-Axis Offset Registers	54
11.15	X-Axis Gain Registers	55
11.16	Y-Axis Gain Registers	56
11.17	Z-Axis Gain Registers	57
11.18	SHAKE_TH: Shake Threshold Register	58
11.19	UD_Z_TH: Up/Down Z Axis Threshold Register.....	59
11.20	UD_X_TH: Up/Down X Axis Threshold Register	60
11.21	RL_Z_TH: Right/Left Z Axis Threshold Register.....	61
11.22	RL_Y_TH: Right/Left Y Axis Threshold Register	62
11.23	FB_Z_TH: Front/Back Z Axis Threshold Register.....	63
11.24	DROP_TH: Drop Threshold Register	64
11.25	TAP_TH: Tap Threshold Register	65
11.26	PCODE: Product Code.....	66
12	Example Configuration	67
12.1	Example: Shake, Tap & Drop thresholds Demo	67
13	Index of Tables	69
14	Revision History.....	71



15 Legal..... 72



1 ORDER INFORMATION

Part Number	Resolution	Order Number	Package	Shipping
MC3253	10 or 14-bit	MC3253	VLGA-16	Tape & Reel, 5Ku

Table 1. Order Information



2 FUNCTIONAL BLOCK DIAGRAM

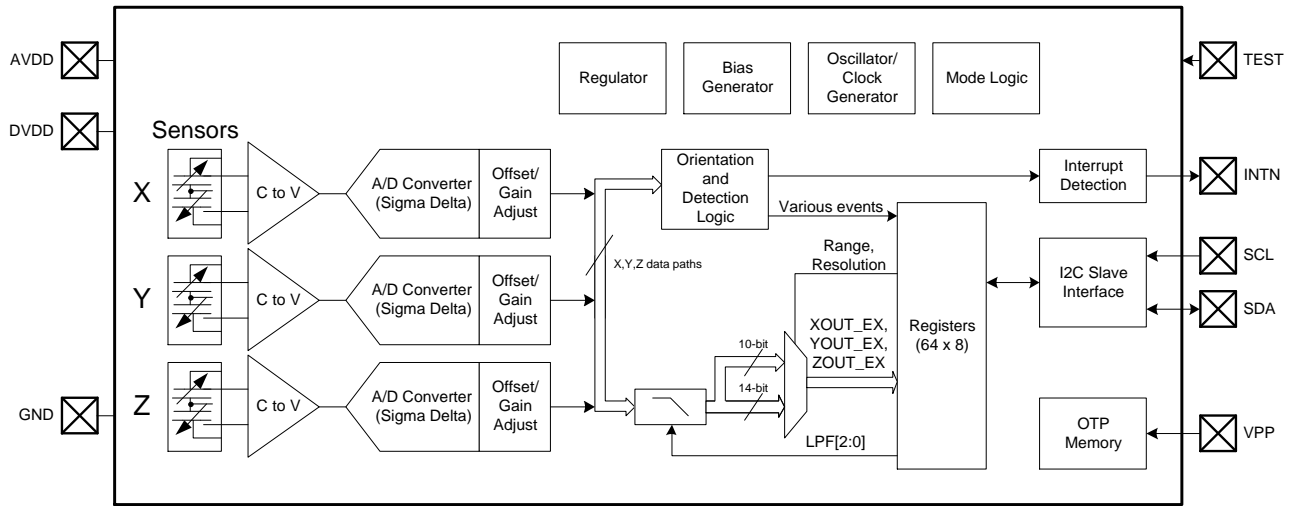

Figure 1. Block Diagram



3 PACKAGING AND PIN DESCRIPTION

3.1 PACKAGE OUTLINE

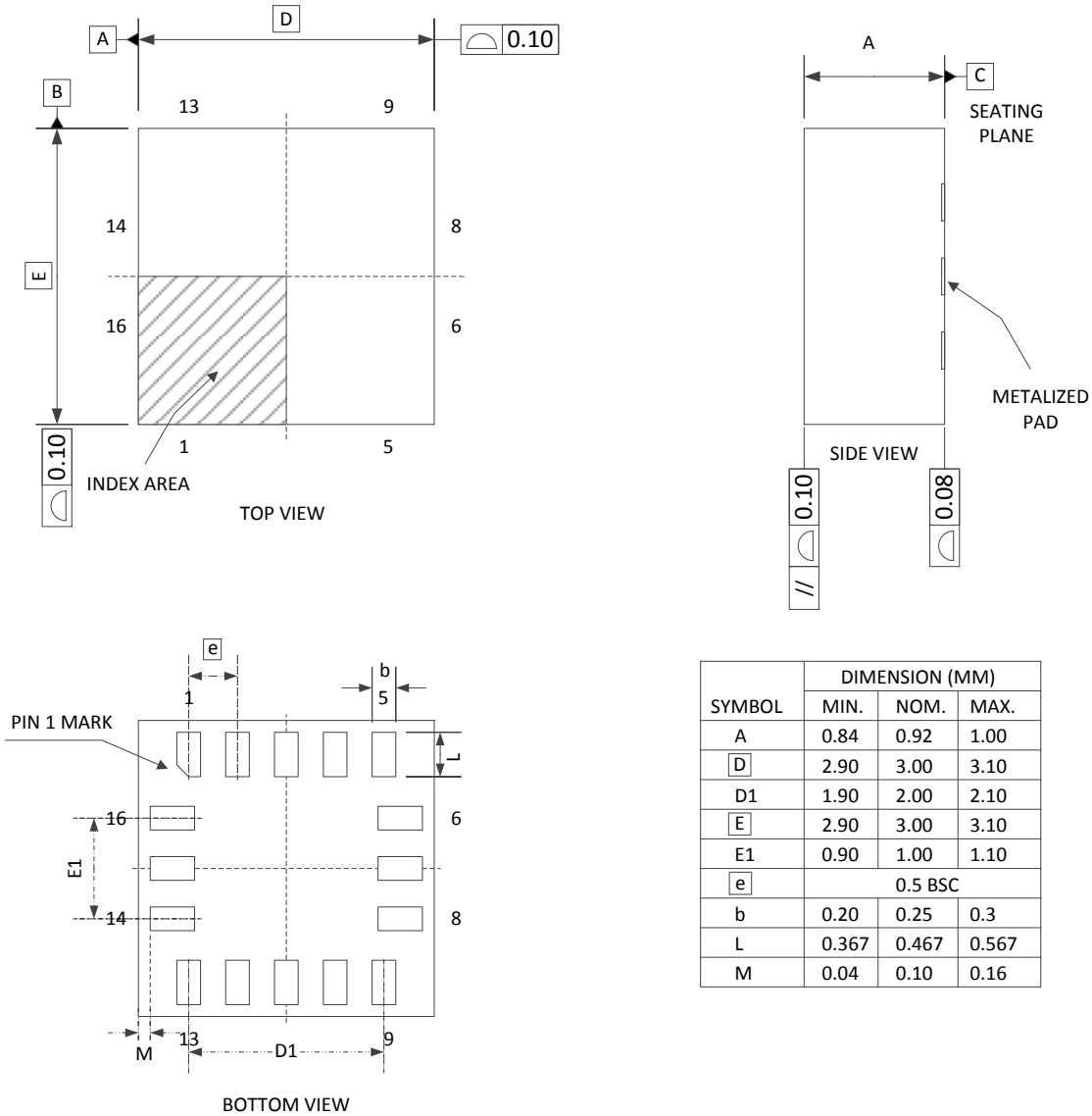

Figure 2. Package Outline and Mechanical Dimensions

NOTE: Additional packaging information and device orientation can be found in Section [11.2 TILT: Status Register](#).



3.2 PIN DESCRIPTION

Pin	Name	Function
1	DVDD	I/O power supply
2	NC	No connect
3	NC	No connect
4	SCL ¹	I2C serial clock input
5	GND	Ground
6	SDA ¹	I2C serial data input/output
7	NC	No connect
8	NC	No connect
9	NC	No connect
10	GND	Ground
11	INTN ²	Interrupt input/output, active LOW ³
12	GND	Ground
13	NC	No connect
14	AVDD	Analog power supply
15	TEST	Optional probe pin
16	VPP	Factory program (GND)

Table 2. Pin Description

Notes:

- 1) This pin requires a pull-up resistor, typically 4.7kΩ to DVDD. Refer to I2C Specification for Fast-Mode devices. Higher resistance values can be used (typically done to reduce current leakage) but such applications are outside the scope of this datasheet.
- 2) This pin can be configured by software to operate either as an open-drain output or push-pull output (MODE: Register). If set to open-drain, then it requires a pull-up resistor, typically 4.7 kΩ to DVDD.
- 3) INTN pin polarity is programmable in the MODE: Register.



3.3 TYPICAL APPLICATION CIRCUIT

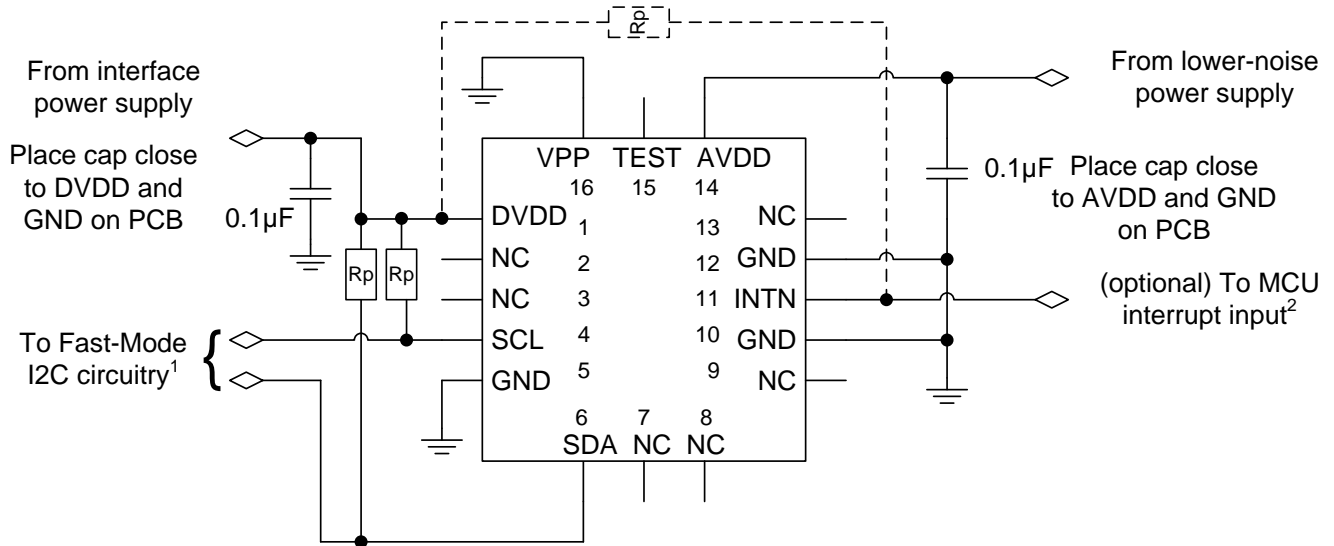

NOTE¹: Rp are typically 4.7 kΩ pull-up resistors to DVDD, per I2C specification. When DVDD is powered down, SDA and SCL will be driven low by internal ESD diodes.
 NOTE²: Attach typical 4.7 kΩ pull-up resistor if INTN is defined as open-drain.

Figure 3. Typical Application Circuit

In typical applications, the interface power supply may contain significant noise from external sources and other circuits which should be kept away from the sensor. Therefore, for some applications a lower-noise power supply might be desirable to power the AVDD pin.



4 SPECIFICATIONS

4.1 ABSOLUTE MAXIMUM RATINGS

Parameters exceeding the Absolute Maximum Ratings may permanently damage the device.

Rating	Symbol	Minimum / Maximum Value	Unit
Supply voltages	Pins DVDD and AVDD	-0.3 / +3.6	V
Acceleration, any axis, 100 μ s	g_{MAX}	10000	g
Ambient operating temperature	T_{OP}	-40 / +85	$^{\circ}$ C
Storage temperature	T_{STG}	-40 / +125	$^{\circ}$ C
ESD human body model	HBM	\pm 2000	V
Latch-up current at $T_{op} = 25$ $^{\circ}$ C	I_{LU}	100	mA
Input voltage to non-power pin	Pins INTN, SCL and SDA	-0.3 / (DVDD + 0.3) or 3.6 whichever is lower	V

Table 3. Absolute Maximum Ratings



4.2 SENSOR CHARACTERISTICS

DVDD, AVDD = 2.8V, $T_{op} = 25^{\circ}\text{C}$ unless otherwise noted

Parameter	Conditions	Min	Typ	Max	Unit
Acceleration range	Resolution and range set in <u>OUTCFG: Output Configuration Register</u>		±2.0 ±4.0 ±8.0		g
Sensitivity	S10 (±2.0g 10-bit resolution) ¹ S10 (±4.0g 10-bit resolution) ¹ S10 (±8.0g 10-bit resolution) ¹ S14 (±8.0g 14-bit resolution) ¹		256 128 64 1024		LSB/g
Sensitivity temperature coefficient ²	$-40 \leq T_{op} \leq +85^{\circ}\text{C}$		±0.02		%/°C
Zero-g offset			±100		mg
Zero-g offset temperature coefficient ²	$-40 \leq T_{op} \leq +85^{\circ}\text{C}$		±1		mg/°C
Noise density ²			100		μg/√Hz
Nonlinearity ²			1		% FS
Cross-axis sensitivity ²	Between any two axes		1		%

Table 4. Sensor Characteristics

¹ The best resolution is realized with the 8Hz bandwidth setting.

² Values are based on device characterization, not tested in production.



4.3 ELECTRICAL AND TIMING CHARACTERISTICS

4.3.1 ELECTRICAL POWER AND INTERNAL CHARACTERISTICS

Parameter	Conditions	Symbol	Min	Typ	Max	Unit
Supply voltage ³		AVDD	2.0		3.6	V
I/O voltage ³		DVDD	1.7		3.6	V
Sample rate tolerance ⁴		Tclock	-5		5	%

Test condition: AVDD = DVDD = 2.8V, T_{op} = 25 °C unless otherwise noted

Parameter	Conditions	Symbol	Min	Typ	Max	Unit
Standby current	AVDD=2.0V AVDD=2.8V AVDD=3.6V	I _{dd0}		1.6 1.8 2.0		μA
WAKE state supply current		I _{dd1024}		190		μA
Pad leakage	Per I/O pad	I _{pad}	-1	0.01	1	μA

Table 5. Electrical Characteristics

³ Min and Max limits are hard limits without additional tolerance.

⁴ Values are based on device characterization, not tested in production.



4.3.2 I2C ELECTRICAL CHARACTERISTICS

Parameter	Symbol	Min	Max	Unit
LOW level input voltage	VIL	-0.5	0.3*DVDD	V
HIGH level input voltage	VIH	0.7*DVDD	-	V
Hysteresis of Schmitt trigger inputs	Vhys	0.05*DVDD	-	V
Output voltage, pin INTN, Iol ≤ 2 mA	Vol	0	0.4	V
	Voh	0	0.9*DVDD	V
Output voltage, pin SDA (open drain), Iol ≤ 1 mA	Vols	-	0.1*DVDD	V
Input current, pins SDA and SCL (input voltage between 0.1*DVDD and 0.9*DVDD max)	Ii	-10	10	μA
Capacitance, pins SDA and SCL ⁵	Ci	-	10	pF

Table 6. I2C Electrical and Timing Characteristics

NOTES:

- If multiple slaves are connected to the I2C signals in addition to this device, only 1 pull-up resistor on each of SDA and SCL should exist. Also, care must be taken to not violate the I2C specification for capacitive loading.
- When DVDD is not powered and set to 0 V, INTN, SDA and SCL will be held to DVDD plus the forward voltage of the internal static protection diodes, typically about 0.6 V.
- When DVDD is disconnected from power or ground (e.g. Hi-Z), the device may become inadvertently powered up through the ESD diodes present on other powered signals.

⁵ Values are based on device characterization, not tested in production.



4.3.3 I2C TIMING CHARACTERISTICS

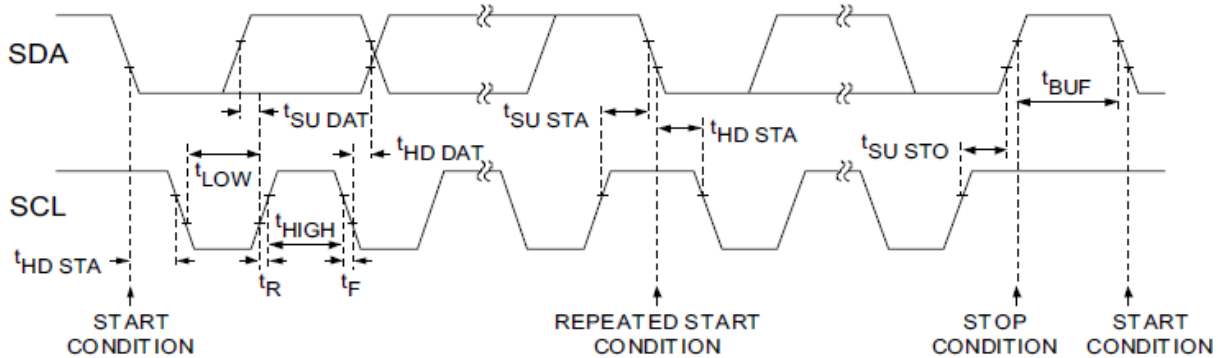

Figure 4. I2C Interface Timing

Parameter	Description	Standard Mode		Fast Mode		Units
		Min	Max	Min	Max	
f_{SCL}	SCL clock frequency	0	100	0	400	kHz
$t_{HD:STA}$	Hold time (repeated) START condition	4.0	-	0.6	-	μs
t_{LOW}	LOW period of the SCL clock	4.7	-	1.3	-	μs
t_{HIGH}	HIGH period of the SCL clock	4.0	-	0.6	-	μs
$t_{SU:STA}$	Set-up time for a repeated START condition	4.7	-	0.6	-	μs
$t_{HD:DAT}$	Data hold time	5.0	-	-	-	μs
$t_{SU:DAT}$	Data set-up time	250	-	100	-	ns
$t_{SU:STO}$	Set-up time for STOP condition	4.0	-	0.6	-	μs
t_{BUF}	Bus free time between a STOP and START	4.7	-	1.3	-	μs

Table 7. I2C Timing Characteristics

NOTE: Values are based on I2C specification requirements, not tested in production.

See also Section [10.3 I2C Message Format](#).



5 GENERAL OPERATION

The internal sampling rate range is fixed at 1024 samples per second. The resulting sensor readings appear as either 10-bit or 14-bit values, depending upon the selection chosen.

5.1 SENSOR SAMPLING

Measurement data is stored in the “extended” registers XOUT_EX, YOUT_EX, and ZOUT_EX. The byte with the lower address of the byte pair is the least significant byte while the byte with the next higher address is the most significant byte. The 10-bit or 14-bit measurement is represented as 2’s complement format.

10-bit samples occupy bits [9:0], with bits [15:9] occupied by the sign bit.

14-bit samples occupy bits [13:0], with bits [15:13] occupied by the sign bit.

The desired resolution and full scale acceleration range of $\pm 2g$, $\pm 4g$ or $\pm 8g$ are set in OUTCFG: Output Configuration Register.

The device sample rate is fixed at 1024 samples/second. The features Tap, Shake, Drop and Orientation detection are available.

Resolution	Acceleration Range	Value per bit (mg/LSB)	Full Scale Negative Reading	Full Scale Positive Reading	Comments
10-bit	$\pm 2g$	~ 3.9	0xFE00 (-512)	0x01FF (+511)	Signed, 2’s complement number, results in registers XOUT_EX_L, XOUT_EX_H, YOUT_EX_L, YOUT_EX_H, ZOUT_EX_L, ZOUT_EX_H (Sign-extended. Integer interpretation also shown)
10-bit	$\pm 4g$	~ 7.8			
10-bit	$\pm 8g$	~ 15.6			
14-bit	$\pm 8g$	~ 0.98	0xE000 (-8192)	0x1FFF (+8191)	Signed, 2’s complement number, results in registers XOUT_EX_L, XOUT_EX_H, YOUT_EX_L, YOUT_EX_H, ZOUT_EX_L, ZOUT_EX_H (Sign-extended. Integer interpretation also shown)

Table 8. Summary of Resolution, Range, and Scaling

Based upon the intended application, filtering of the data samples may be desired. The device has several low-pass filter (LPF) options for the raw sample data, intended to filter out undesired high frequency components. Related to this LPF setting is the GINT interrupt rate, which can be modified to occur based upon the LPF roll-off frequency, rather than the sample



rate (fixed at 1024 samples/second). See Section [8.2 GINT Interrupt](#) for more on this option. The cutoff points for the LPF can be set from 8Hz to 512 Hz. These, and the controls for the GINT rate, are described in Section [11.11 OUTCFG: Output Configuration Register](#).

5.2 OFFSET AND GAIN CALIBRATION

Digital offset and gain calibration can be performed on the sensor, if necessary, in order to reduce the effects of post-assembly influences and stresses which may cause the sensor readings to be offset from their factory values. The register controls are described in Sections [11.12](#) through [11.17](#).



6 OPERATIONAL STATES

The device has two states of operation: STANDBY (the default state after power-up), and WAKE.

The STANDBY state offers the lowest power consumption. In this state, the I2C interface is active and all register reads and writes are allowed. There is no event detection, sampling, or acceleration measurement in the STANDBY state. Internal clocking is halted. Complete access to the register set is allowed in this state, but interrupts cannot be serviced. The device defaults to the STANDBY state following power-up. The time to change states from STANDBY to WAKE is less than 10 μ s and does not depend upon the sample rate.

Registers can be written (and therefore resolution, range, thresholds and other settings can be changed) only when the device is in STANDBY state.

The I2C interface allows write access to all registers only in the STANDBY state. In WAKE state, the only I2C register write access permitted is to the MODE: Register. Full read access is allowed in all states.

State	I2C Bus	Description
STANDBY	Device responds to I2C bus (R/W)	Device is powered; Registers can be accessed via I2C. Lowest power state. No interrupt generation, internal clocking disabled. Default power-on state.
WAKE	Device responds to I2C bus (Read)	Continuous sampling and reading of sense data. All registers except the <u>MODE: Register</u> are read-only.

Table 9. Operational States



7 OPERATIONAL STATE FLOW

Figure 5. Operational State Flow shows the operational state flow for the device. The device defaults to STANDBY following power-on.

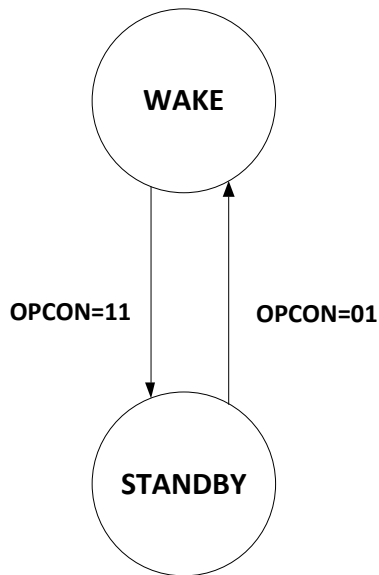

Figure 5. Operational State Flow

The operational state may be forced to a specific state by writing into the OPCON bits, as shown below. Two bits are specified in order to promote software compatibility with other mCube devices. The operational state will stay in the mode specified until changed:

Action	Setting	Effect
Force Wake State	OPCON[1:0] = 01	<ul style="list-style-type: none"> • Switch to WAKE state and stay there • Continuous sampling
Force Standby State	OPCON[1:0] = 11	<ul style="list-style-type: none"> • Switch to STANDBY state and stay there • Disable sensor and event sampling

Table 10. Forcing Operational States



8 INTERRUPTS

The sensor device utilizes output pin INTN to signal to an external microprocessor that an event has been sensed. The microprocessor would contain an interrupt service routine which would perform certain tasks after receiving this interrupt and reading the associated status bits, perhaps after the product was put into a certain orientation or had been tapped. The microprocessor would set up the registers in the sensor so that when a specific event is detected, the microprocessor would receive the interrupt and the interrupt service routine would be executed.

For products that will instead use polling, the method of reading sensor data would be slightly different. Instead of receiving an interrupt when an event occurs, the microprocessor must periodically poll the sensor and read status data while the INTN pin is not used. For most applications this is likely best done at the sensor sampling rate or faster. Note that at least one I2C STOP condition must be present between samples in order for the sensor to update the sample data registers.

In this case, the event detection bits (TAPD, SHAKED, DROPD) and associated interrupt enable bits in the TILT: Status Register must still be set up as if interrupts would occur in order for the status registers to be updated with proper data.

Although the INTN is not connected, the registers in the sensor will still contain valid status and so can be used by software to know the orientation of the product or if an event has occurred.

8.1 ENABLING AND CLEARING INTERRUPTS

The INTEN: Interrupt Enable Register determines which events generate interrupts. When an event is detected, it is masked with an interrupt enable bit in this register and the corresponding status bit is set in the TILT: Status Register. Multiple interrupt events might be reported at the same time in the TILT: Status Register, so software must interpret and prioritize the results.

The pin INTN is cleared during the next I2C bus cycle after the device ID has been recognized by the device.

When an interrupt is triggered, the first I2C read access to the device clears INTN pin. The condition (TAPD, SHAKED, DROPD) that generated the interrupt will remain held in the TILT: Status Register until it is read. Note that the orientation bit-fields POLA and BAFR are continuously updated (every sample) in the TILT: Status Register and are not held. Note that multiple interrupts may be active at the same time, and so a software routine reading the TILT: Status Register should account for this.



Any of the following interrupts can be enabled or disabled in the INTEN: Interrupt Enable Register and DROP: Drop Event Control Register.

- Front/Back Interrupt
- Up/Down/Left/Right (portrait / landscape) Interrupt
- Tap Detection Interrupt
- GINT (real-time motion tracking, generate interrupt each sample period)
- Shake on X-axis, Shake on Y-axis, and Shake on Z-axis
- Drop event detection

The INTEN: Interrupt Enable Register contains many of the interrupt enable bits. The drop interrupt enable bit DINT is located in the DROP: Drop Event Control Register.

8.2 INTERRUPT SUPPORT

The following table shows the relationship between motion events and interrupt enable bits for determining when the device will generate an interrupt. No measurements or interrupts are generated in the STANDBY state.

Motion Event	Interrupt Enable Bits
Portrait/Landscape or Front/Back orientation change	FBINT = 1 PLINT = 1
Shake	SHINTX = 1 SHINTY = 1 SHINTZ = 1
Tap	TINT = 1
Drop	DINT = 1
Sample Update	GINT = 1

Table 11. Interrupt Support



8.3 GINT INTERRUPT

The GINT interrupt can trigger on each sample period (default), or be “filtered” by the bandwidth setting of the LPF. If the OUTCFG: Output Configuration Register IRATE bit is inactive, then the GINT interrupt will trigger each sample period. If the IRATE bit is active, the GINT interrupt rate will be updated based on the low-pass filter setting controlled by bit-field LPF.



8.4 EVENT DETECTION

The detection logic monitors and compares sensor outputs against the comparisons selected by the application software. Each type of event can be masked by a separate bit in the INTEN: Interrupt Enable Register. The following table shows how the detection events are evaluated.

Event	X Axis	Y Axis	Z Axis
Up	$ Z < (UD_Z_TH)$ and $ X > (UD_X_TH)$ and $X < 0$ ¹		
Down	$ Z < (UD_Z_TH)$ and $ X > (UD_X_TH)$ and $X > 0$ ¹		
Right		$ Z < (RL_Z_TH)$ and $ Y > (RL_Y_TH)$ and $Y < 0$ ²	
Left		$ Z < (RL_Z_TH)$ and $ Y > (RL_Y_TH)$ and $Y > 0$ ²	
Front			$Z > FB_Z_TH$ ³
Back			$Z < -1 * FB_Z_TH$ ³
SHAKED ⁴	$ X > 1.3g \pm SHAKE_TH$	$ Y > 1.3g \pm SHAKE_TH$	$ Z > 1.3g \pm SHAKE_TH$
DROPD ⁵	$ X < 0.5g \pm DROP_TH$	$ Y < 0.5g \pm DROP_TH$	$ Z < 0.5g \pm DROP_TH$
TAPD ⁶	$ X > TAP_TH$	$ Y > TAP_TH$	$ Z > TAP_TH$

Table 12. Detection Logic Event Evaluation

¹ Up/Down Z threshold is programmable from 0.425g to 1.172g, up/down X threshold is programmable from $|X|$ to $|X| + 0.747g$.

² Right/left Z threshold is programmable from 0.425g to 1.172g, right/left Y threshold is programmable from $|Y|$ to $|Y| + 0.747g$.

³ Front/back Z threshold is programmable from 0.174g to 0.547g.

⁴ SHAKED event is triggered when any axis $> SHAKE_TH$, programmable from 0.925g to 1.1672g.

⁵ DROPD event is triggered when condition (a) $|X| + |Y| + |Z| < 0.5g + DROP_TH$ or condition (b) $|X| < 0.5g \pm DROP_TH$ and $|Y| < 0.5g \pm DROP_TH$ and $|Z| < 0.5g \pm DROP_TH$, this is user selectable. The range is from 0.125g to 0.872g.

⁶ TAPD event is triggered by $|X| > TAP_TH$ or $|Y| > TAP_TH$ g or $|Z| > TAP_TH$, where TAP_TH is programmable and any combination of X, Y, and Z may be selected.



9 ORIENTATION DETECTION

The MC3253 allows an application to determine the orientation of the device. The current orientation of the device is reported as Left, Right, Up, Down, Front, and Back for each sampling period. This information generates the Portrait/Landscape status bits in the TILT: Status Register.

9.1 ORIENTATION HYSTERESIS

Hysteresis can be added to portrait/landscape and front/back detection by modifying the default threshold offset values. See the specific sections below for more information.

9.2 PORTRAIT/LANDSCAPE EVENTS

Portrait/landscape detection is a combination of left, right, up, and down events, also partially dependent upon Z sensor readings.

The default comparison angle for portrait/landscape is 45 degrees when evaluating differences between LEFT, RIGHT, UP, and DOWN, as long as the magnitude of Z is < 0.8g (default). See Figure 6.

By increasing the threshold values written to the UD_X_TH: Up/Down X Axis Threshold and RL_Y_TH: Right/Left Y Axis Threshold, hysteresis can be introduced to the angle of evaluation. These registers add a small offset to the default X and Y values and introduce additional margin in the portrait/landscape detection logic.

For most applications, the same value should be written to both registers.

When the device orientation is in the hysteresis region, the device will report orientation as “unknown”. When this reading is reported, in order to implement a hysteresis effect for orientation, high-level software should use the last known portrait/landscape information.

In the example shown in Figure 7 the evaluation angle has been decreased to 40 degrees in each threshold, such that there is a 10 degree “deadband” or hysteresis-area between LEFT/RIGHT and DOWN/UP areas. The circle represents the acceleration in the Z axis, which has a default of 0.8g, or about a 33 degree tilt relative to the Z axis.



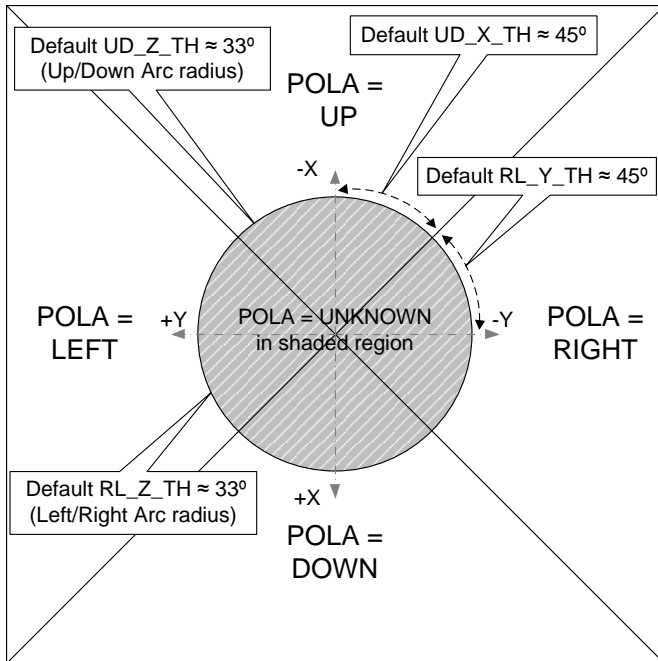

Figure 6. Default Orientation Settings

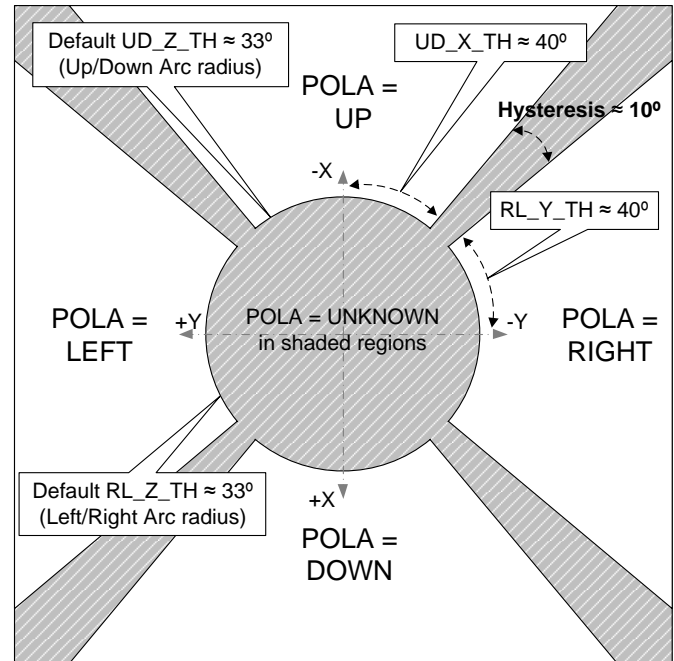

Figure 7. Example Simple Orientation Hysteresis = 10 degrees

The Z threshold for each direction can also be adjusted, as shown in [Figure 8](#). This has the effect of altering the angle relative to the Z axis which causes the orientation state to change.

[Figure 9](#) shows an example of setting the UD_Z_TH and RL_Z_TH registers to different values, as well as setting the UD_X_TH and RL_Y_TH registers to different values. However for most applications the same value should be written to both registers in both cases.



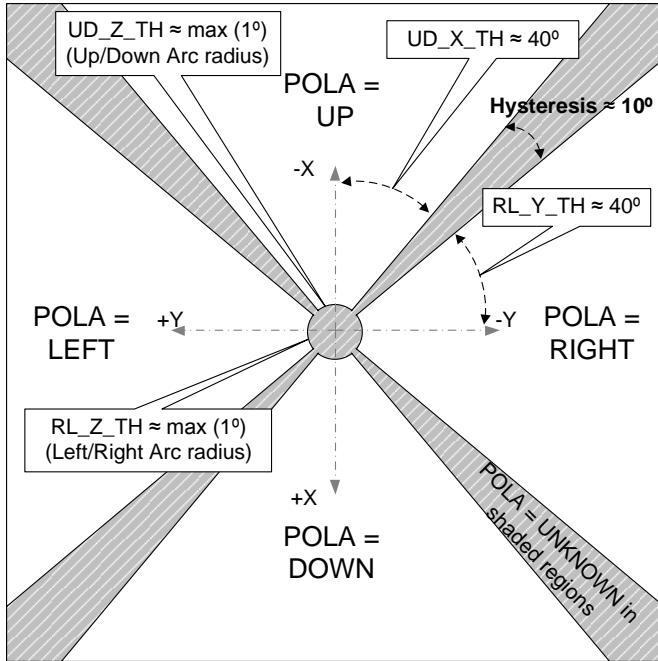

Figure 8. Effect of Changing UD_Z_TH Threshold with Hysteresis = 10 degrees

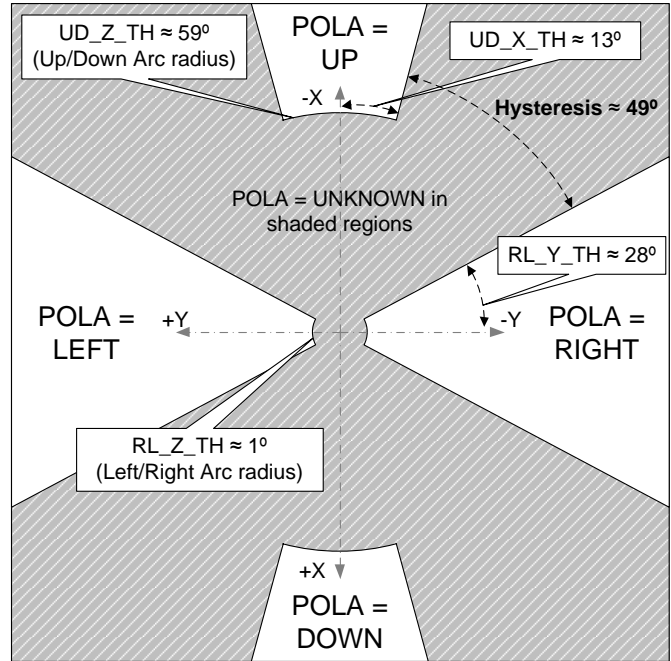

Figure 9. Example of Complex Thresholds for Up/Down X, Right/Left Y, Up/Down Z & Right/Left Z

Table 13 summarizes the portrait/landscape event evaluation criteria. Some example threshold values and the corresponding trip angle and amount of hysteresis are shown in Table 14.

Event	X Axis	Y Axis	Z Axis
Up	$ Z < (UD_Z_TH)$ and $ X > (UD_X_TH)$ and $X < 0$		
Down	$ Z < (UD_Z_TH)$ and $ X > (UD_X_TH)$ and $X > 0$		
Right		$ Z < (RL_Z_TH)$ and $ Y > (RL_Y_TH)$ and $Y < 0$	
Left		$ Z < (RL_Z_TH)$ and $ Y > (RL_Y_TH)$ and $Y > 0$	

Table 13. Portrait/Landscape Event Evaluation Criteria



Registers UD_X_TH or RL_Y_TH Threshold Value	Trip Angle (approx. degrees)	Resulting Hysteresis (approx. degrees)	Corresponding g Value (approximate)
0x00	45	0	0.72
0x10	43	4	0.68
0x20	41	8	0.66
0x30	39	12	0.63
0x40	37	16	0.61
0x50	36	20	0.58
0x60	34	24	0.55
...
0xFF	15	64	0.26

Table 14. Some Approximate X and Y-axis Portrait/Landscape Evaluation Angles and Values

Registers UD_Z_TH or RL_Z_TH Threshold Value	Trip Angle (approx. degrees)	Corresponding g Value (approximate)
0x80	67	0.43
0x90	64	0.47
...
0xE0	48	0.71
0xF0	45	0.75
0x00	40	0.80
0x10	36	0.85
0x20	32	0.89
...
0x70	9	1.13
0x7F	3	Max (~1.17)*

Table 15. Some Approximate Z-axis Portrait/Landscape Evaluation Angles and Values

NOTE*: Max values >1.0g are possible, to cover offset variations.

Table 16 shows the orientation event conditions for the portrait/landscape detection hardware.



POLA[2:0]	Left	Right	Down	Up	Description/Comments
000	0	0	0	0	Unknown
001	1	0	0	0	Left/landscape
010	0	1	0	0	Right/landscape
101	0	0	1	0	Down/portrait
110	0	0	0	1	Up/portrait

Table 16. Portrait/Landscape TILT: Status Register Assignments



9.3 FRONT/BACK EVENTS

The front/back detection compares ZOUT with a low g value, ranging from 0.174g to 0.547g, with the offset from 0.174g specified by the FB_Z_TH: Front/Back Z Axis Threshold Register. This equates to a range of approximately 55 degrees.

The BAFR bit-field is updated in the TILT: Status Register according to the front/back orientation sensed by the device. Additional hysteresis can be added to front/back detection by increasing the front/back Z axis threshold value located in the FB_Z_TH: Front/Back Z Axis Threshold Register.

When the front/back orientation of the device is in the deadband region, BAFR bit-field will report the orientation as “unknown”. The default settings (0x00) equate to a range of approximately 25 degrees where the sensor will report BAFR = FRONT (or BACK). The maximum settings (0xFF) equate to about a 80 degree range. See Figure 10 and Figure 11.

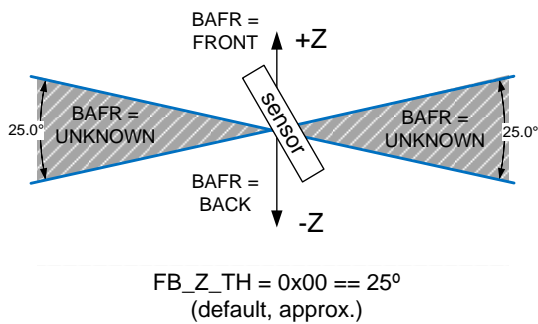

Figure 10. Default Setting of FB_Z_TH for BAFR Readings

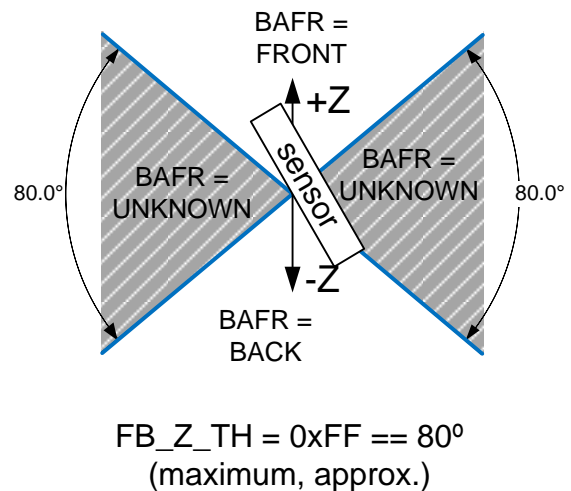

Figure 11. Maximum setting of FB_Z_TH for BAFR Readings

The bit settings for the BAFR bit-field are shown in Table 17. Table 18 shows the front/back orientation evaluation criteria. Some example threshold values and the corresponding trip angles are shown in Table 19. All values are approximate and not tested in production.



BAFR[1:0]	Status
00	Unknown condition of front or back
01	Front: Device is in orientation e. in Figure 18
10	Back: Device is in orientation f. in Figure 18
11	Reserved

Table 17. BAFR Bit Assignments in the TILT: Status Register

Event	X Axis	Y Axis	Z Axis
Front			$Z > FB_Z_TH$
Back			$Z < -1 * FB_Z_TH$

Table 18. Front/Back Event Evaluation

Threshold Value	FB_Z_TH Trip Angle (approx. degrees)
0x00	25
0x10	28
0x20	32
0x30	35
0x40	39
0x50	42
0x60	46
0x70	49
...	...
0xFF	80

Table 19. Approximate Front/Back Evaluation Angles and Values



9.4 SHAKE DETECTION

The threshold for detecting a shake event can be set to a range of values around a 1.3g baseline. The shake threshold can range from 0.925g to 1.672g. The value is a signed, 2's complement number. Resolution is approximately 2.9mg/bit.

A shake event will be triggered when high-g values are sensed for a sufficient number of samples.

SHDB: Shake Debounce Register can be set to count from 1 to 63 events before setting the SHAKED bit in the TILT: Status Register. Higher values yield longer evaluation periods. See Figure 12 and Figure 13.

Shake detection can be any combination of axes. To enable detection even when not using interrupts, set the corresponding SHINTX, SHINTY, or SHINTZ bit-fields in the INTEN: Interrupt Enable Register.

Event	X Axis		Y Axis		Z Axis
Shake	$ X > +1.3g \pm \text{Threshold}$	or	$ Y > +1.3g \pm \text{Threshold}$	or	$ Z > +1.3g \pm \text{Threshold}$

Table 20. SHAKE Event Evaluation (Baseline + Offset)

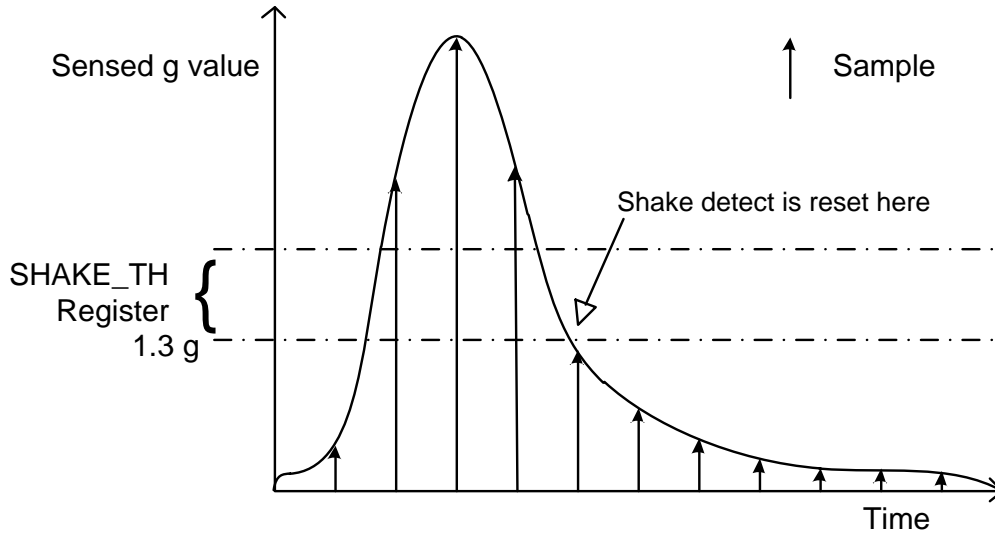

Shake Debounce Register == 4 but the sensed g value is above 1.3g + SHAKE_TH for only 3 samples. Shake event is not detected.

Figure 12. Example Use of Shake Detection Hardware – Shake Not Detected



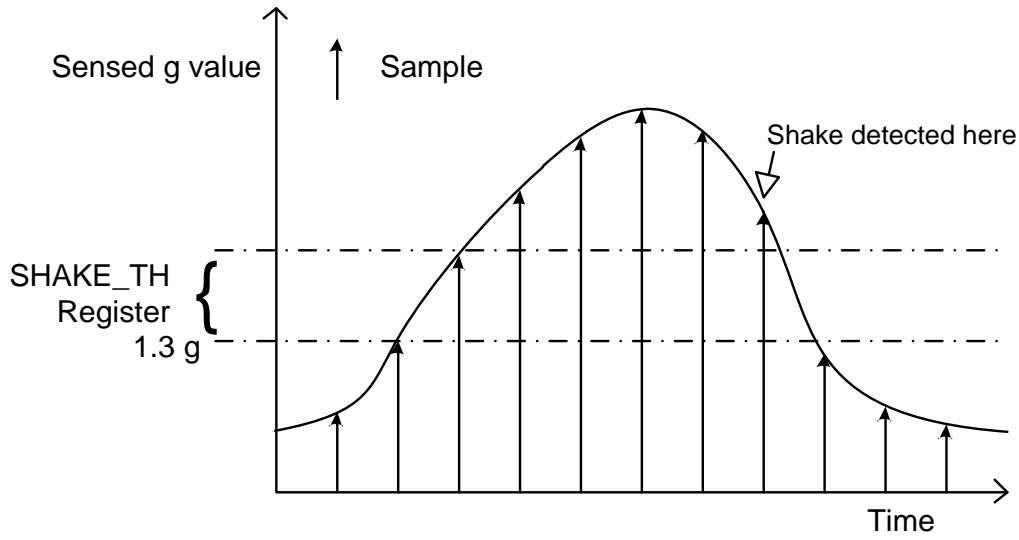

Shake Debounce Register == 4 and the sensed g value is above 1.3g + SHAKE_TH for 5 samples. Shake event is detected.

Figure 13. Example Use of Shake Detection Hardware – Shake Detected



9.5 DROP DETECTION

Drop detection is defined as a low-g acceleration applied to all axes. Two modes of drop detection are supported:

Mode A: Drop detection is a summation of all 3 axes:

Drop is detected when:

$$\text{Sum}(\text{mag}(X) + \text{mag}(Y) + \text{mag}(Z)) < 0.5g \pm \text{DROP_TH Threshold}$$

else Drop not detected;

Mode B: Drop detection is the logical AND of three comparisons:

Drop is detected when:

$$\text{mag}(X) < 0.5g \pm \text{DROP_TH Threshold and}$$

$$\text{mag}(Y) < 0.5g \pm \text{DROP_TH Threshold and}$$

$$\text{mag}(Z) < 0.5g \pm \text{DROP_TH Threshold}$$

else Drop not detected.

The typical drop threshold value is on the order of < 0.5g for all axes. The drop detection range is from 0.125g to 0.872g. The drop debounce value (bit-field DDB in the DROP: Drop Event Control Register) can filter from 1 to 8 consecutive events before setting the drop interrupt.

Event	X Axis		Y Axis		Z Axis
Drop Mode A	Sum (X	+	Y	+	Z) < 0.5g ± DROP_TH
Drop Mode B	X < 0.5g ± DROP_TH	and	Y < 0.5g ± DROP_TH	and	Z < 0.5g ± DROP_TH

Table 21. Drop Event Evaluation



9.6 TAP DETECTION

On-chip tap detection hardware allows the device to detect user events such as on-screen button presses. Tap detection can be enabled or disabled on each axis via the TAPEN: Tap Detection Enable Register.

To detect fast, impulse events like a tap, the TAPP: Tap Pulse Register should be written with a tap pulse parameter that sets the maximum number of sample periods that a TAPD event may exceed the threshold before it is ignored by the detection logic. Sensed values that are above the threshold for long periods of time typically do not correspond to tap events.

For example, setting the pulse value to 5 requires that the tap impulse exceed the threshold for at least 1 sample period and up to 5 sample periods. The tap detection hardware is rearmed after the sensed value is below the threshold. See the example in Figure 14 and Figure 15.

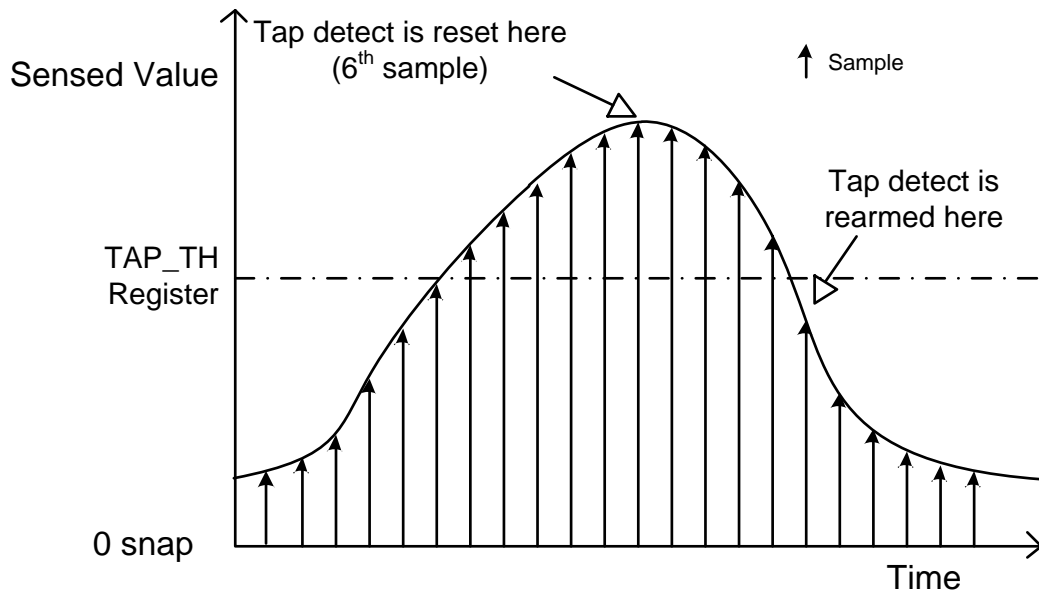

Tap Pulse Register == 5 but the sensed value is above the threshold for 10 samples. No tap is detected.

Figure 14. Example Use of Tap Detection Hardware – No Tap Detected



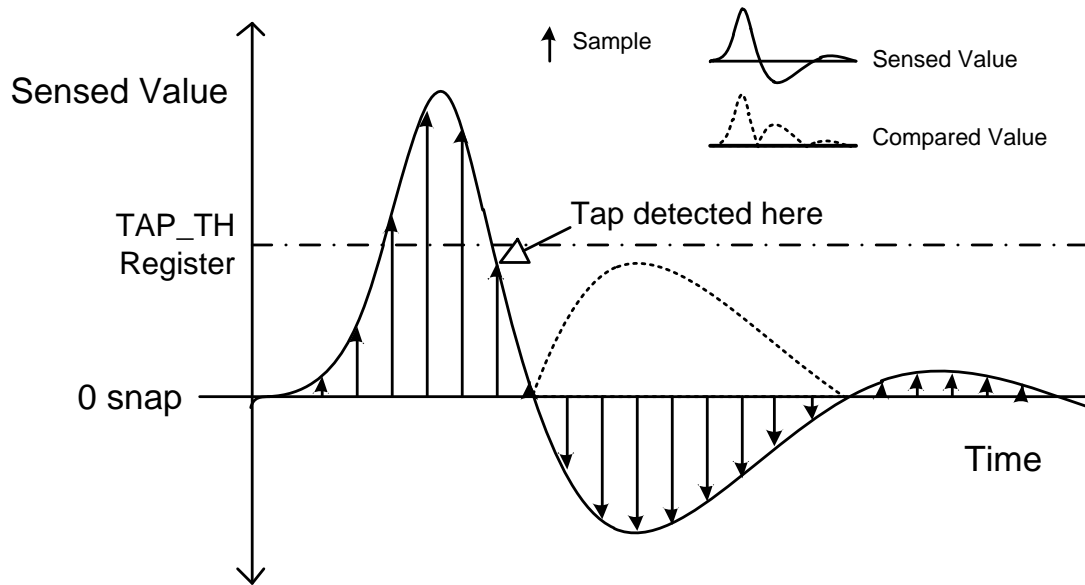

Tap Pulse Register == 5 and the sensed value is above the threshold for 3 samples. Tap is detected.

Figure 15. Example Use of Tap Detection Hardware – Tap Detected

The threshold value, set by writing the TAP_TH: Tap Threshold Register, is an 8-bit unsigned number that species the threshold detection level for all tap events. This value is not an offset, but a magnitude which determines the minimum level for a valid tap event.

Event	X Axis	Y Axis	Z Axis
Tap	$ X > TAP_TH$	$ Y > TAP_TH$	$ Z > TAP_TH$

Table 22. Default Tap Event Evaluation



9.7 CONTINUOUS SAMPLING

The device has the ability to read all sampled readings in a continuous sampling fashion. The device always updates the XOUT_EX, YOUT_EX, and ZOUT_EX registers at 1024 samples/second.

An optional interrupt can be generated each time the sample registers have been updated (GINT interrupt bit in the INTEN: Interrupt Enable Register). See Sections 8.3 and 11.11 for GINT operation and options.



10 I2C INTERFACE

10.1 PHYSICAL INTERFACE

The I2C slave interface operates at a maximum speed of 400 kHz. The SDA (data) is an open-drain, bi-directional pin and the SCL (clock) is an input pin.

The device always operates as an I2C slave.

An I2C master initiates all communication and data transfers and generates the SCL clock that synchronizes the data transfer. The I2C device address is 0x4C (8-bit address 0x98).

The I2C interface remains active as long as power is applied to the DVDD and AVDD pins. In STANDBY state the device responds to I2C read and write cycles, but interrupts cannot be serviced or cleared. All registers can be written in the STANDBY state, but in WAKE only the MODE: Register can be modified.

Internally, the registers which are used to store samples are clocked by the sample clock gated by I2C activity. Therefore, in order to allow the device to collect and present samples in the sample registers at least one I2C STOP condition must be present between samples.

Refer to the I2C specification for a detailed discussion of the protocol. Per I2C requirements, SDA is an open drain, bi-directional pin. SCL and SDA each require an external pull-up resistor, typically 4.7 kΩ. Refer also to Figure 3. Typical Application Circuit.

10.2 TIMING

See Section 4.3.3 I2C Timing Characteristics for I2C timing requirements.

10.3 I2C MESSAGE FORMAT

The device uses the following general format for writing to the internal registers. The I2C master generates a START condition, and then supplies the device ID, 0x4C or 1001100. The 8th bit is the R/W# flag (write cycle = 0). The device pulls SDA low during the 9th clock cycle indicating a positive ACK. This means, from an 8-bit point of view of an external I2C master, writes should be written to address 0x98 and reads will occur by reading address 0x99.

The second byte is the 8-bit register address of the device to access, and the last byte is the data to write.

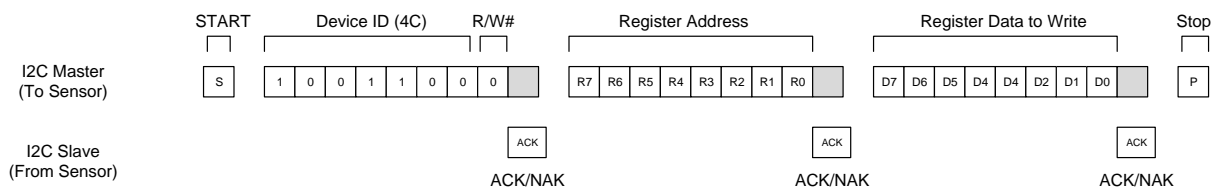

Figure 16. I2C Message Format, Write Cycle, Single Register Write



In a read cycle, the I2C master writes the device ID (R/W# = 0) and register address to be read. The master issues a RESTART condition and then writes the device ID with the R/W# flag set to '1'. The device shifts out the contents of the register address.

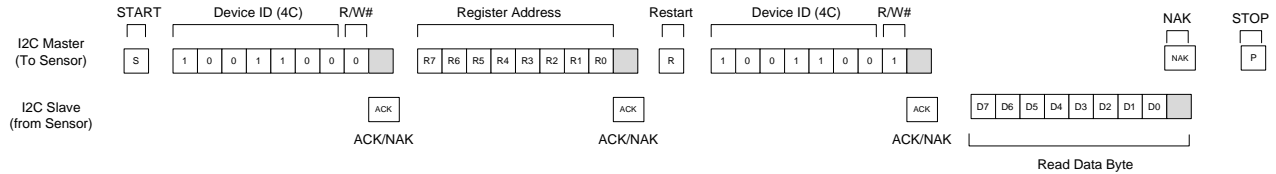

Figure 17. I2C Message Format, Read Cycle, Single Register Read

The I2C master may write or read consecutive register addresses by writing or reading additional bytes after the first access. The device will internally increment the register address.

If an I2C burst read operation reads past register address 0x12 the internal address pointer “wraps” to address 0x03 and the contents of the TILT: Status Register are returned. This allows application software to burst read the contents of the six extended registers and the relevant device state registers in a single I2C cycle.



11 REGISTER INTERFACE

The device has a simple register interface which allows a MCU or I2C master to configure and monitor all aspects of the device. This section lists an overview of user programmable registers. By convention, Bit 0 is the least significant bit (LSB) of a byte register.

Two registers are needed in order to contain each sample, the XOUT_EX, YOUT_EX & ZOUT_EX: X, Y, Z-Axis Extended Accelerometer Registers. The least significant byte is located in the register with a lower address (e.g. XOUT_EX_L), followed by the most significant byte in the next higher address (e.g. XOUT_EX_H).



11.1 REGISTER SUMMARY

Addr	Name	Description	Bit 7	Bit 6	Bit 5	Bit 4	Bit 3	Bit 2	Bit 1	Bit 0	POR Value	R/W ⁶
0x00-0x02	RESERVED ⁷											
0x03	TILT	Tilt Status Register	SHAKED	DROPD	TAPD	POLA [2]	POLA [1]	POLA [0]	BAFR [1]	BAFR [0]	0x00	R
0x04	OPSTAT	Operational State Status Register	OTPA	0	Resv ⁹	0	0	0	OPSTAT [1]	OPSTAT [0]	0x03	R
0x05	RESERVED ⁷											
0x06	INTEN	Interrupt Enable Register	SHINTX	SHINTY	SHINTZ	GINT	ASINT	TINT	PLINT	FBINT	0x00	W
0x07	MODE	Mode Register	IAH	IPP	Resv ⁹	Resv ⁹	Resv ⁹	0 ⁸	OPCON [1]	OPCON [0]	0x03	W
0x08	RESERVED ⁷											
0x09	TAPEN	Tap Detection Enable Register	ZDA	YDA	XDA	Resv ⁹	Resv ⁹	Resv ⁹	Resv ⁹	Resv ⁹	0x00	W
0x0A	TAPP	Tap Pulse Register	Resv ⁹	Resv ⁹	Resv ⁹	Resv ⁹	TAPP [3]	TAPP [2]	TAPP [1]	TAPP [0]	0x00	W
0x0B	DROP	Drop Event Control Register	DROP_MODE	DINT	Resv ⁹	Resv ⁹	Resv ⁹	DROP_DB[2]	DROP_DB[1]	DROP_DB[0]	0x00	W
0x0C	SHDB	Shake Debounce Register	Resv ⁹	Resv ⁹	SHDB [5]	SHDB [4]	SHDB [3]	SHDB [2]	SHDB [1]	SHDB [0]	0x00	W
0x0D	XOUT_EX_L	XOUT Extended Register	XOUT_EX[7]	XOUT_EX[6]	XOUT_EX[5]	XOUT_EX[4]	XOUT_EX[3]	XOUT_EX[2]	XOUT_EX[1]	XOUT_EX[0]	0x00	R
0x0E	XOUT_EX_H	XOUT Extended Register	XOUT_EX[15]	XOUT_EX[14]	XOUT_EX[13]	XOUT_EX[12]	XOUT_EX[11]	XOUT_EX[10]	XOUT_EX[9]	XOUT_EX[8]	0x00	R
0x0F	YOUT_EX_L	YOUT Extended Register	YOUT_EX[7]	YOUT_EX[6]	YOUT_EX[5]	YOUT_EX[4]	YOUT_EX[3]	YOUT_EX[2]	YOUT_EX[1]	YOUT_EX[0]	0x00	R
0x10	YOUT_EX_H	YOUT Extended Register	YOUT_EX[15]	YOUT_EX[14]	YOUT_EX[13]	YOUT_EX[12]	YOUT_EX[11]	YOUT_EX[10]	YOUT_EX[9]	YOUT_EX[8]	0x00	R
0x11	ZOUT_EX_L	ZOUT Extended Register	ZOUT_EX[7]	ZOUT_EX[6]	ZOUT_EX[5]	ZOUT_EX[4]	ZOUT_EX[3]	ZOUT_EX[2]	ZOUT_EX[1]	ZOUT_EX[0]	0x00	R
0x12	ZOUT_EX_H	ZOUT Extended Register	ZOUT_EX[15]	ZOUT_EX[14]	ZOUT_EX[13]	ZOUT_EX[12]	ZOUT_EX[11]	ZOUT_EX[10]	ZOUT_EX[9]	ZOUT_EX[8]	0x00	R
0x13-0x1F	RESERVED ⁷											
0x20	OUTCFG	Output Configuration Register	IRATE	LPF [2]	LPF [1]	LPF [0]	HIRES [1]	HIRES [0]	1 ¹⁰	1 ¹⁰	0x03	W
0x21	XOFFL	X-Offset LSB Register	XOFF[7]	XOFF[6]	XOFF[5]	XOFF[4]	XOFF[3]	XOFF[2]	XOFF[1]	XOFF[0]	Per chip	W
0x22	XOFFH	X-Offset MSB Register	XGAIN[8]	Resv ⁹	XOFF[13]	XOFF[12]	XOFF[11]	XOFF[10]	XOFF[9]	XOFF[8]	Per chip	W
0x23	YOFFL	Y-Offset LSB Register	YOFF[7]	YOFF[6]	YOFF[5]	YOFF[4]	YOFF[3]	YOFF[2]	YOFF[1]	YOFF[0]	Per chip	W

⁶ 'R' registers are read-only, via external I2C access. 'W' registers are read-write, via external I2C access.

⁷ Registers designated as 'RESERVED' should not be accessed by software.

⁸ Software must always write a zero '0' to this bit.

⁹ Bits designated as 'Resv' are reserved for future use.

¹⁰ Software must always write a one '1' to this bit.



Addr	Name	Description	Bit 7	Bit 6	Bit 5	Bit 4	Bit 3	Bit 2	Bit 1	Bit 0	POR Value	R/W ⁶
0x24	YOFFH	Y-Offset MSB Register	YGAIN[8]	Resv ⁹	YOFF[13]	YOFF[12]	YOFF[11]	YOFF[10]	YOFF[9]	YOFF[8]	Per chip	W
0x25	ZOFFL	Z-Offset LSB Register	ZOFF[7]	ZOFF[6]	ZOFF[5]	ZOFF[4]	ZOFF[3]	ZOFF[2]	ZOFF[1]	ZOFF[0]	Per chip	W
0x26	ZOFFH	Z-Offset MSB Register	ZGAIN[8]	Resv ⁹	ZOFF[13]	ZOFF[12]	ZOFF[11]	ZOFF[10]	ZOFF[9]	ZOFF[8]	Per chip	W
0x27	XGAIN	X Gain Register	XGAIN[7]	XGAIN[6]	XGAIN[5]	XGAIN[4]	XGAIN[3]	XGAIN[2]	XGAIN[1]	XGAIN[0]	Per chip	W
0x28	YGAIN	Y Gain Register	YGAIN[7]	YGAIN[6]	YGAIN[5]	YGAIN[4]	YGAIN[3]	YGAIN[2]	YGAIN[1]	YGAIN[0]	Per chip	W
0x29	ZGAIN	Z Gain Register	ZGAIN[7]	ZGAIN[6]	ZGAIN[5]	ZGAIN[4]	ZGAIN[3]	ZGAIN[2]	ZGAIN[1]	ZGAIN[0]	Per chip	W
0x2A	RESERVED ⁷											
0x2B	SHAKE_TH	Shake Threshold Register	SHAKE_TH[7]	SHAKE_TH[6]	SHAKE_TH[5]	SHAKE_TH[4]	SHAKE_TH[3]	SHAKE_TH[2]	SHAKE_TH[1]	SHAKE_TH[0]	0x00	W
0x2C	UD_Z_TH	Up/Down Z Threshold Register	UD_Z_TH[7]	UD_Z_TH[6]	UD_Z_TH[5]	UD_Z_TH[4]	UD_Z_TH[3]	UD_Z_TH[2]	UD_Z_TH[1]	UD_Z_TH[0]	0x00	W
0x2D	UD_X_TH	Up/Down X Threshold Register	UD_X_TH[7]	UD_X_TH[6]	UD_X_TH[5]	UD_X_TH[4]	UD_X_TH[3]	UD_X_TH[2]	UD_X_TH[1]	UD_X_TH[0]	0x00	W
0x2E	RL_Z_TH	Right/Left Z Threshold Register	RL_Z_TH[7]	RL_Z_TH[6]	RL_Z_TH[5]	RL_Z_TH[4]	RL_Z_TH[3]	RL_Z_TH[2]	RL_Z_TH[1]	RL_Z_TH[0]	0x00	W
0x2F	RL_Y_TH	Right/Left Y Threshold Register	RL_Y_TH[7]	RL_Y_TH[6]	RL_Y_TH[5]	RL_Y_TH[4]	RL_Y_TH[3]	RL_Y_TH[2]	RL_Y_TH[1]	RL_Y_TH[0]	0x00	W
0x30	FB_Z_TH	Front/Back Z Threshold Register	FB_Z_TH[7]	FB_Z_TH[6]	FB_Z_TH[5]	FB_Z_TH[4]	FB_Z_TH[3]	FB_Z_TH[2]	FB_Z_TH[1]	FB_Z_TH[0]	0x00	W
0x31	DROP_TH	Drop Threshold Register	DROP_TH[7]	DROP_TH[6]	DROP_TH[5]	DROP_TH[4]	DROP_TH[3]	DROP_TH[2]	DROP_TH[1]	DROP_TH[0]	0x00	W
0x32	TAP_TH	Tap Threshold Register	TAP_TH[7]	TAP_TH[6]	TAP_TH[5]	TAP_TH[4]	TAP_TH[3]	TAP_TH[2]	TAP_TH[1]	TAP_TH[0]	0x00	W
0x33 to 0x3A	RESERVED ⁷											
0x3B	PCODE	Product Code	1	0	0	0	1	0	0	0	0x88	R
0x3C to 0x3F	RESERVED ⁷											

Table 23. Register Summary¹¹

¹¹ No registers are updated with new event status or samples while an I2C cycle is in process.



11.2 TILT: STATUS REGISTER

This register contains bits which are set when a motion event is detected. Each event has a corresponding interrupt enable which can mask any combination of events. The event detection bits (SHAKED, DROPD, TAPD) remain held until the register is read by the I2C interface. Note that the orientation bit-fields POLA and BAFR are continuously updated (every sample) in the TILT: Status Register and are not held. Note that multiple interrupts may be active at the same time, and so a software routine reading the TILT: Status Register should account for this. Refer to Figure 18. Package Orientation and Figure 19. Package Axis Reference.

Addr	Name	Description	Bit 7	Bit 6	Bit 5	Bit 4	Bit 3	Bit 2	Bit 1	Bit 0	POR Value	R/W
0x03	TILT	Tilt Status Register	SHAKED	DROPD	TAPD	POLA [2]	POLA [1]	POLA [0]	BAFR [1]	BAFR [0]	0x00	R

BAFR[1:0]	Back or Front 00: Unknown condition of front or back 01: Front – Device is in orientation e in <u>Figure 18. Package Orientation</u> . 10: Back – Device is in orientation f in <u>Figure 18. Package Orientation</u> . 11: Reserved
POLA[2:0]	Portrait or Landscape 000: Unknown condition of up, down, left or right 001: Left – Device is in orientation d in <u>Figure 18. Package Orientation</u> . 010: Right – Device is in orientation a in <u>Figure 18. Package Orientation</u> . 011: Reserved 100: Reserved 101: Down – Device is in orientation c in <u>Figure 18. Package Orientation</u> . 110: Up – Device is in orientation b in <u>Figure 18. Package Orientation</u> . 111: Reserved
TAPD	0: Tap event not detected 1: Tap event detected
DROPD	0: Drop event not detected 1: Drop event detected
SHAKED	0: Shake event not detected 1: Shake event detected

Table 24. TILT Status Register Settings



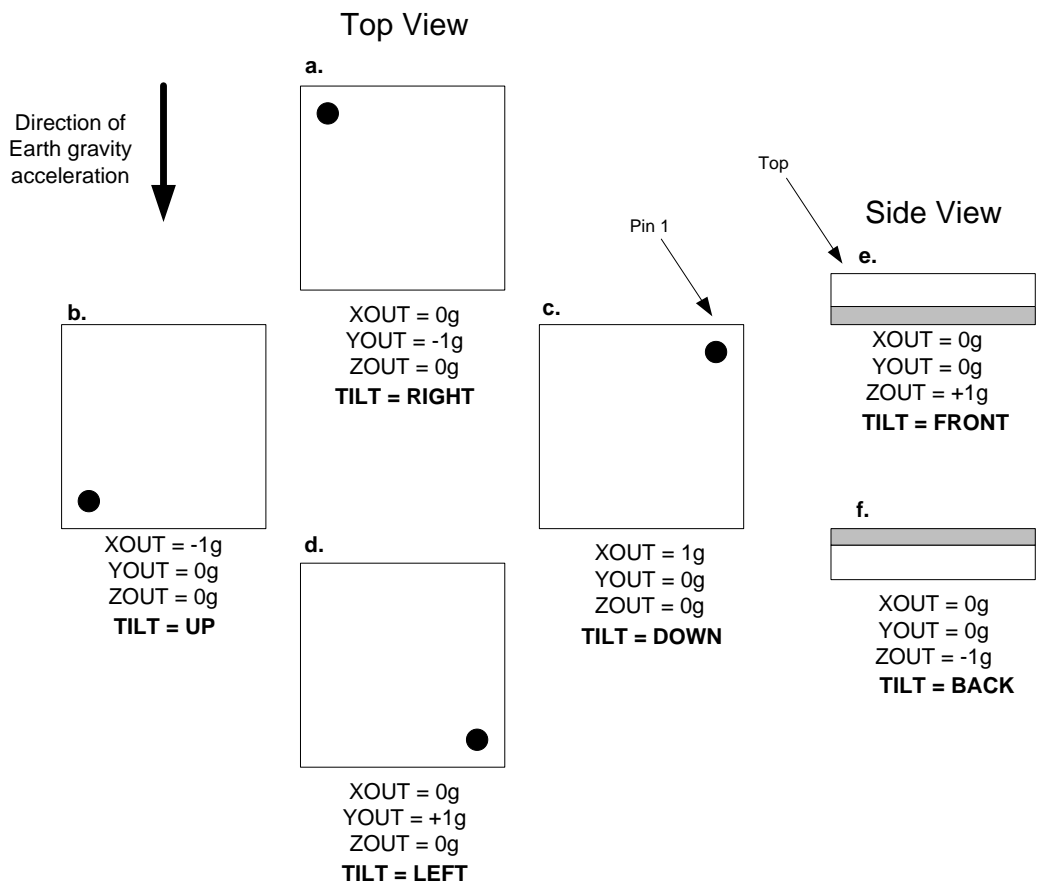

Figure 18. Package Orientation

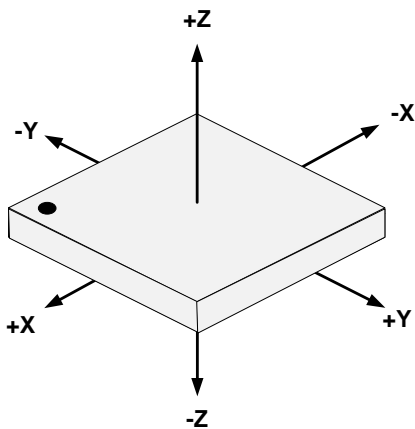

Figure 19. Package Axis Reference



11.3 OPSTAT: OPERATIONAL STATE STATUS REGISTER

The Operational State status register reports which operational state the device is in, either WAKE or STANDBY as shown in [Table 25. Operational State Status Register](#)

Addr	Name	Description	Bit 7	Bit 6	Bit 5	Bit 4	Bit 3	Bit 2	Bit 1	Bit 0	POR Value	R/W
0x04	OPSTAT	Operational State Status Register	OTPA	0	Resv	0	0	0	OPSTAT [1]	OPSTAT [0]	0x03	R

OPSTAT[1:0]	Sampling State Register Status, Wait State Register Status 00: Reserved 01: Device is in WAKE state 10: Reserved 11: Device is in STANDBY state, no sampling
Resv	Reserved
OTPA	One-time Programming (OTP) activity status 0: Internal memory is idle and the device is ready for use 1: Internal memory is active and the device is not yet ready for use

Table 25. Operational State Status Register



11.4 INTEN: INTERRUPT ENABLE REGISTER

The interrupt enable register enables or disables interrupts on various motion events. If the corresponding interrupt enable bit is set, a matching event will generate an interrupt transition on the external interrupt pin, INTN. To enable the drop interrupt, set the DINT control bit in the DROP: Drop Event Control Register.

When an interrupt is triggered, the first I2C access to the device will clear the external interrupt pin, but the condition (TAPD, SHAKED, DROPD) that generated the interrupt will remain held in the TILT: Status Register until it is read. Note that the orientation bit-fields POLA and BAFR are continuously updated (every sample) in the TILT: Status Register and are not held.

Addr	Name	Description	Bit 7	Bit 6	Bit 5	Bit 4	Bit 3	Bit 2	Bit 1	Bit 0	POR Value	R/W
0x06	INTEN	Interrupt Enable Register	SHINTX	SHINTY	SHINTZ	GINT	Resv	TINT	PLINT	FBINT	0x00	W

FBINT	Front / Back Interrupt 0: Disable interrupt on front/back position change 1: Enable interrupt on front/back position change
PLINT	Portrait / Landscape Interrupt 0: Disable interrupt on up/down/left/right position change 1: Enable interrupt on up/down/left/right position change
TINT	Tap Interrupt 0: Disable interrupt on tap detection 1: Enable interrupt on tap detection
Resv	Reserved
GINT	Generate Interrupt 0: Disable automatic interrupt after each measurement 1: Enable automatic interrupt after each measurement is updated in XOUT, YOUT, or ZOUT. The interrupt occurs for each measurement, not value change. See Section 8.3.
SHINTX	Shake Interrupt, X-axis 0: Disable X-axis interrupt, SHAKED is not set in <u>TILT: Status Register</u> upon event 1 : Enable X-axis interrupt, SHAKED is set in <u>TILT: Status Register</u> upon event
SHINTY	Shake Interrupt, Y-axis 0: Disable Y-axis interrupt, SHAKED bit is not set in <u>TILT: Status Register</u> upon event 1 : Enable Y-axis interrupt, SHAKED bit is set in <u>TILT: Status Register</u> upon event
SHINTZ	Shake Interrupt, Z-axis 0: Disable Z-axis interrupt, SHAKED bit is not set in <u>TILT: Status Register</u> upon event 1 : Enable Z-axis interrupt, SHAKED bit is set in <u>TILT: Status Register</u> upon event

Table 26. Interrupt Enable Register Settings



11.5 MODE: REGISTER

The MODE register controls the active operating state of the device. This register can be written from either operational state (STANDBY or WAKE).

Addr	Name	Description	Bit 7	Bit 6	Bit 5	Bit 4	Bit 3	Bit 2	Bit 1	Bit 0	POR Value	R/W
0x07	MODE	Mode Register	IAH	IPP	Resv*	Resv*	Resv*	0*	OPCON [1]	OPCON [0]	0x03	W

NOTE*: Software must always write a zero '0' to Bit 2. Bits 3, 4 and 5 are reserved.

OPCON [1:0]	00: Reserved	Set Device Operational State. WAKE or STANDBY
	01: Move to WAKE state and remain there	
	10: Reserved	
	11: Move to STANDBY state and remain there (STANDBY is the default POR state)	
IPP	0: Interrupt pin INTN is open drain (default) and requires an external pull-up to AVDD.	Interrupt Push Pull
	1: Interrupt pin INTN is push-pull. No external pull-up resistor should be installed.	
IAH	0: Interrupt pin INTN is active low	Interrupt Active High
	1: Interrupt pin INTN is active high	

Table 27. Mode Register Functionality



11.6 TAPEN: TAP DETECTION ENABLE REGISTER

This register allows individual tap/pulse detection on each axis. Setting XDA, YDA, or ZDA adds the corresponding axis to tap event detection. See also Section [9.6 Tap Detection](#).

Addr	Name	Description	Bit 7	Bit 6	Bit 5	Bit 4	Bit 3	Bit 2	Bit 1	Bit 0	POR Value	R/W
0x09	TAPEN	Tap Detection Enable Register	ZDA	YDA	XDA	Resv	Resv	Resv	Resv	Resv	0x00	W

XDA	0: Disable Tap detection on X-axis 1: Enable Tap detection on X-axis
YDA	0: Disable Tap detection on Y-axis 1: Enable Tap detection on Y-axis
ZDA	0: Disable Tap detection on Z-axis 1: Enable Tap detection on Z-axis

Table 28. TAPEN Register Settings



11.7 TAPP: TAP PULSE REGISTER

This value sets the number of samples for which a tap pulse must exceed the TAP_TH threshold before it is rejected as not a tap event. If the values detected by the sensor exceed the TAP_TH threshold for longer than the reject count, no tap event is detected and the interrupt is not set. See also Section 9.6 Tap Detection.

Addr	Name	Description	Bit 7	Bit 6	Bit 5	Bit 4	Bit 3	Bit 2	Bit 1	Bit 0	POR Value	R/W
0x0A	TAPP	TAP Pulse Register	Resv	Resv	Resv	Resv	TAPP [3]	TAPP [2]	TAPP [1]	TAPP [0]	0x00	W

TAPP [3:0]	Tap Detection Sample Periods (n)	Description
0x0	1	This tap detection filtering requires the sensed values to exceed the TAP_TH threshold level for n sample periods. When they have, the sensor will set TAPD bit in the <u>TILT: Status Register</u> . In addition, if the TINT tap interrupt is enabled in the <u>INTEN: Interrupt Enable Register</u> then an interrupt will be generated by the device.
0x1	2	
0x2	3	
0x3	4	
...	5 ≤ n ≤ 15	
0xF	16	

Table 29. TAPP Tap Pulse Register Settings



11.8 DROP: DROP EVENT CONTROL REGISTER

Addr	Name	Description	Bit 7	Bit 6	Bit 5	Bit 4	Bit 3	Bit 2	Bit 1	Bit 0	POR Value	R/W
0x0B	DROP	Drop Event Control Register	DROP_MODE	DINT	Resv	Resv	Resv	DROP_DB[2]	DROP_DB[1]	DROP_DB[0]	0x00	W

DROP_DB[2:0]	Drop Debounce 000: 1 drop event 001: 2 adjacent drop events 010: 3 adjacent drop events ... : 4 ≤ n ≤ 7 adjacent drop events 111: 8 adjacent drop events	Drop event debounce value, the number of drop events detected must reach this count for the final event to be valid.
DINT	Drop Interrupt 0: Disable drop event interrupt 1: Enable drop event interrupt	The DROPD bit in the <u>TILT: Status Register</u> will be set upon event occurrence regardless of this bit setting.
DROP_MODE	Drop Mode 0: Mode A: Drop detection is a summation of all 3 axes: Drop is detected when: Sum(mag(X) + mag(Y) + mag(Z)) < 0.5g ± DROP_TH Threshold else Drop not detected; 1: Mode B: Drop detection is the logical AND of three comparisons: Drop is detected when: mag(X) < 0.5g ± DROP_TH Threshold and mag(Y) < 0.5g ± DROP_TH Threshold and mag(Z) < 0.5g ± DROP_TH Threshold else Drop not detected.	

Table 30. Drop Event Control Register Settings



11.9 SHDB: SHAKE DEBOUNCE REGISTER

The shake debounce register allows a 1 to 63 event count to be required before a valid shake event is detected or an interrupt is generated. The debounce value applies to all 3-axes.

Addr	Name	Description	Bit 7	Bit 6	Bit 5	Bit 4	Bit 3	Bit 2	Bit 1	Bit 0	POR Value	R/W
0x0C	SHDB	Shake Debounce Register	Resv	Resv	SHDB [5]	SHDB [4]	SHDB [3]	SHDB [2]	SHDB [1]	SHDB [0]	0x00	W

SHDB[5:0]	Adjacent Shake Events (n)	Description
0x01	1	Shake detection debounce filtering requires n adjacent shake detection events in order to trigger a shake event and set the SHAKED bit in the <u>TILT: Status Register</u> . In addition, if the SHINTX, SHINTY or SHINTZ bits are set in the <u>INTEN: Interrupt Enable Register</u> and that event occurs, then an interrupt will be generated by the device.
0x02	2	
0x03	3	
....	$4 \leq n \leq 62$	
0x3F	63	

Table 31. SH_DB Shake Debounce Register Settings



11.10 XOUT_EX, YOUT_EX & ZOUT_EX: X, Y, Z-AXIS EXTENDED ACCELEROMETER REGISTERS

The measurements from sensors for the 3-axes are written to the registers XOUT_EX, YOUT_EX & ZOUT_EX: X, Y, Z-Axis Extended Accelerometer Registers. The most-significant bit of the value is the sign bit, and is sign extended to the higher bits. Note that all 3 axes are sampled and updated simultaneously. If an I2C burst read operation reads past register address 0x12 the internal address pointer “wraps” to address 0x03 and the contents of the TILT: Status Register are returned. This allows application software to burst read the contents of the six extended registers and relevant device state registers in a single I2C read cycle.

Once an I2C start bit has been recognized by the sensor, registers will not be updated until an I2C stop bit has occurred. Therefore, if software desires to read the low and high byte registers ‘atomically’, knowing that the values have not been changed, it should do so by issuing a start bit, reading one register, then reading the other register then issuing a stop bit. Note that all 6 registers may be read in one burst with the same effect.

10-bit samples occupy bits [9:0], with bits [15:9] occupied by the sign bit.

14-bit samples occupy bits [13:0], with bits [15:13] occupied by the sign bit.

Addr	Name	Description	Bit 7	Bit 6	Bit 5	Bit 4	Bit 3	Bit 2	Bit 1	Bit 0	POR Value	R/W
0x0D	XOUT_EX_L	XOUT Extended Register	XOUT_EX[7]	XOUT_EX[6]	XOUT_EX[5]	XOUT_EX[4]	XOUT_EX[3]	XOUT_EX[2]	XOUT_EX[1]	XOUT_EX[0]	0x00	R
0x0E	XOUT_EX_H	XOUT Extended Register	XOUT_EX[15]	XOUT_EX[14]	XOUT_EX[13]	XOUT_EX[12]	XOUT_EX[11]	XOUT_EX[10]	XOUT_EX[9]	XOUT_EX[8]	0x00	R
0x0F	YOUT_EX_L	YOUT Extended Register	YOUT_EX[7]	YOUT_EX[6]	YOUT_EX[5]	YOUT_EX[4]	YOUT_EX[3]	YOUT_EX[2]	YOUT_EX[1]	YOUT_EX[0]	0x00	R
0x10	YOUT_EX_H	YOUT Extended Register	YOUT_EX[15]	YOUT_EX[14]	YOUT_EX[13]	YOUT_EX[12]	YOUT_EX[11]	YOUT_EX[10]	YOUT_EX[9]	YOUT_EX[8]	0x00	R
0x11	ZOUT_EX_L	ZOUT Extended Register	ZOUT_EX[7]	ZOUT_EX[6]	ZOUT_EX[5]	ZOUT_EX[4]	ZOUT_EX[3]	ZOUT_EX[2]	ZOUT_EX[1]	ZOUT_EX[0]	0x00	R
0x12	ZOUT_EX_H	ZOUT Extended Register	ZOUT_EX[15]	ZOUT_EX[14]	ZOUT_EX[13]	ZOUT_EX[12]	ZOUT_EX[11]	ZOUT_EX[10]	ZOUT_EX[9]	ZOUT_EX[8]	0x00	R

Table 32. Extended Accelerometer Registers



11.11 OUTCFG: OUTPUT CONFIGURATION REGISTER

This register can be used to set the resolution of the accelerometer measurements, the maximum g-range and low-pass filter settings for sampling and the bandwidth setting for the GINT interrupt. The lowest 2 bits must be set by software to binary b'11.

Addr	Name	Description	Bit 7	Bit 6	Bit 5	Bit 4	Bit 3	Bit 2	Bit 1	Bit 0	POR Value	R/W
0x20	OUTCFG	Output Configuration Register	IRATE	LPF [2]	LPF [1]	LPF [0]	HIRES [1]	HIRES [0]	1*	1*	0x03	W

NOTE*: Software must always write a '1' to bits 0 and 1.

HIRES[1:0]	Accelerometer g Ranges and Resolution 00: Select +/- 2g range, 10-bit resolution 01: Select +/- 4g range, 10-bit resolution 10: Select +/- 8g range, 10-bit resolution 11: Select +/- 8g range, 14-bit resolution
LPF[2:0]	Low Pass Filter bandwidth 000: Low-pass filter set to 512 Hz bandwidth 001: Low-pass filter set to 256 Hz bandwidth 010: Low-pass filter set to 128 Hz bandwidth 011: Low-pass filter set to 64 Hz bandwidth 100: Low-pass filter set to 32 Hz bandwidth 101: Low-pass filter set to 16 Hz bandwidth 110: Low-pass filter set to 8 Hz bandwidth 111: Reserved
IRATE	GINT sample rate trigger 0: GINT interrupt updates at sample acquisition rate 1: GINT interrupt updates at LPF bandwidth setting determined by LPF[2:0] If IRATE = '1', the GINT interrupt will occur at the same rate as the bandwidth setting of the LPF. This prevents extraneous sample acquisition interrupts at a rate greater than the LPF setting.

Table 33. OUTCFG Resolution and Range Select Register Settings



11.12 X-AXIS OFFSET REGISTERS

This register contains a signed 2's complement 14-bit value applied as an offset adjustment to the output of the sensor values, prior to being sent to the OUT_EX registers. The Power-On-Reset value for each chip is unique and is set as part of factory calibration. If necessary, this value can be overwritten by software.

NOTE: When modifying these registers with new gain or offset values, software should perform a read-modify-write type of access to ensure that unrelated bits do not get changed inadvertently.

Addr	Name	Description	Bit 7	Bit 6	Bit 5	Bit 4	Bit 3	Bit 2	Bit 1	Bit 0	POR Value	R/W
0x21	XOFFL	X-Offset LSB Register	XOFF[7]	XOFF[6]	XOFF[5]	XOFF[4]	XOFF[3]	XOFF[2]	XOFF[1]	XOFF[0]	Per chip	W
0x22	XOFFH	X-Offset MSB Register	XGAIN[8]	Resv	XOFF[13]	XOFF[12]	XOFF[11]	XOFF[10]	XOFF[9]	XOFF[8]	Per chip	W



11.13 Y-AXIS OFFSET REGISTERS

This register contains a signed 2's complement 14-bit value applied as an offset adjustment to the output of the sensor values, prior to being sent to the OUT_EX registers. The Power-On-Reset value for each chip is unique and is set as part of factory calibration. If necessary, this value can be overwritten by software.

NOTE: When modifying these registers with new gain or offset values, software should perform a read-modify-write type of access to ensure that unrelated bits do not get changed inadvertently.

Addr	Name	Description	Bit 7	Bit 6	Bit 5	Bit 4	Bit 3	Bit 2	Bit 1	Bit 0	POR Value	R/W
0x23	YOFFL	Y-Offset LSB Register	YOFF[7]	YOFF[6]	YOFF[5]	YOFF[4]	YOFF[3]	YOFF[2]	YOFF[1]	YOFF[0]	Per chip	W
0x24	YOFFH	Y-Offset MSB Register	YGAIN[8]	Resv	YOFF[13]	YOFF[12]	YOFF[11]	YOFF[10]	YOFF[9]	YOFF[8]	Per chip	W



11.14 Z-AXIS OFFSET REGISTERS

This register contains a signed 2’s complement 14-bit value applied as an offset adjustment to the output of the sensor values, prior to being sent to the OUT_EX registers. The Power-On-Reset value for each chip is unique and is set as part of factory calibration. If necessary, this value can be overwritten by software.

NOTE: When modifying these registers with new gain or offset values, software should perform a read-modify-write type of access to ensure that unrelated bits do not get changed inadvertently.

Addr	Name	Description	Bit 7	Bit 6	Bit 5	Bit 4	Bit 3	Bit 2	Bit 1	Bit 0	POR Value	R/W
0x25	ZOFFL	Z-Offset LSB Register	ZOFF[7]	ZOFF[6]	ZOFF[5]	ZOFF[4]	ZOFF[3]	ZOFF[2]	ZOFF[1]	ZOFF[0]	Per chip	W
0x26	ZOFFH	Z-Offset MSB Register	ZGAIN[8]	Resv	ZOFF[13]	ZOFF[12]	ZOFF[11]	ZOFF[10]	ZOFF[9]	ZOFF[8]	Per chip	W



11.15 X-AXIS GAIN REGISTERS

The gain value is an unsigned 9-bit number.

NOTE: When modifying these registers with new gain or offset values, software should perform a read-modify-write type of access to ensure that unrelated bits do not get changed inadvertently.

Addr	Name	Description	Bit 7	Bit 6	Bit 5	Bit 4	Bit 3	Bit 2	Bit 1	Bit 0	POR Value	R/W
0x22	XOFFH	X-Offset MSB Register	XGAIN[8]	Resv	XOFF[13]	XOFF[12]	XOFF[11]	XOFF[10]	XOFF[9]	XOFF[8]	Per chip	W
0x27	XGAIN	X Gain Register	XGAIN[7]	XGAIN[6]	XGAIN[5]	XGAIN[4]	XGAIN[3]	XGAIN[2]	XGAIN[1]	XGAIN[0]	Per chip	W



11.16 Y-AXIS GAIN REGISTERS

The gain value is an unsigned 9-bit number.

NOTE: When modifying these registers with new gain or offset values, software should perform a read-modify-write type of access to ensure that unrelated bits do not get changed inadvertently.

Addr	Name	Description	Bit 7	Bit 6	Bit 5	Bit 4	Bit 3	Bit 2	Bit 1	Bit 0	POR Value	R/W
0x24	YOFFH	Y-Offset MSB Register	YGAIN[8]	Resv	YOFF[13]	YOFF[12]	YOFF[11]	YOFF[10]	YOFF[9]	YOFF[8]	Per chip	W
0x28	YGAIN	Y Gain Register	YGAIN[7]	YGAIN[6]	YGAIN[5]	YGAIN[4]	YGAIN[3]	YGAIN[2]	YGAIN[1]	YGAIN[0]	Per chip	W



11.17 Z-AXIS GAIN REGISTERS

The gain value is an unsigned 9-bit number.

NOTE: When modifying these registers with new gain or offset values, software should perform a read-modify-write type of access to ensure that unrelated bits do not get changed inadvertently.

Addr	Name	Description	Bit 7	Bit 6	Bit 5	Bit 4	Bit 3	Bit 2	Bit 1	Bit 0	POR Value	R/W
0x26	ZOFFH	Z-Offset MSB Register	ZGAIN[8]	Resv	ZOFF[13]	ZOFF[12]	ZOFF[11]	ZOFF[10]	ZOFF[9]	ZOFF[8]	Per chip	W
0x29	ZGAIN	Z Gain Register	ZGAIN[7]	ZGAIN[6]	ZGAIN[5]	ZGAIN[4]	ZGAIN[3]	ZGAIN[2]	ZGAIN[1]	ZGAIN[0]	Per chip	W



11.18 SHAKE_TH: SHAKE THRESHOLD REGISTER

SHAKE_TH has a baseline value of 1.3g plus a threshold, SHAKE_TH. The shake threshold can range from 0.925g to 1.672g. The value is an 8-bit signed 2’s complement number. The resolution is approximately 2.9mg/bit. See also Section [9.4 Shake Detection](#).

$$\begin{aligned} \text{Shake Event} = & \text{ (mag(X) > 1.3g + SHAKE_TH) or} \\ & \text{ (mag(Y) > 1.3g + SHAKE_TH) or} \\ & \text{ (mag(Z) > 1.3g + SHAKE_TH)} \end{aligned}$$

Addr	Name	Description	Bit 7	Bit 6	Bit 5	Bit 4	Bit 3	Bit 2	Bit 1	Bit 0	POR Value	R/W
0x2B	SHAKE_TH	Shake Threshold Register	Signed 2’s complement value								0x00	W

SHAKE_TH[7:0]	Description (~2.9mg/LSB)
0x80	Shake threshold is 0.925g
0x00	Shake threshold is 1.3g
0x7F	Shake threshold is 1.672g

Table 34. SHAKE_TH Threshold Register Settings



11.19 UD_Z_TH: UP/DOWN Z AXIS THRESHOLD REGISTER

The threshold value, UD_Z_TH[7:0] is an 8-bit signed 2’s complement number that can range from 0.425g to 1.172g, for determination of the POLA orientation bits. The resolution is approximately 2.9mg/bit. See also Section 9.2 Portrait/Landscape.

Addr	Name	Description	Bit 7	Bit 6	Bit 5	Bit 4	Bit 3	Bit 2	Bit 1	Bit 0	POR Value	R/W
0x2C	UD_Z_TH	Up/Down Z Axis Threshold Register	Signed 2’s complement value								0x00	W

UD_Z_TH[7:0]	Description (~2.9mg/LSB)
0x80	Up/down Z axis threshold is 0.425g
0x00	Up/down Z axis threshold is 0.8g
0x7F	Up/down Z axis threshold is 1.172g

Table 35. Up/Down Z-axis Threshold Register Settings



11.20 UD_X_TH: UP/DOWN X AXIS THRESHOLD REGISTER

This 8-bit unsigned value is an offset that is added to the magnitude of the X-axis accelerometer measurement. The range of the offset is 0g to 0.747g; the resolution is approximately 2.9mg/bit. See also Section 9.2 Portrait/Landscape.

Increasing this value in conjunction with the RL_Y_TH: Right/Left Y Axis Threshold Register widens the deadband in portrait /landscape detection.

For most applications, the same value should be written to both registers.

Addr	Name	Description	Bit 7	Bit 6	Bit 5	Bit 4	Bit 3	Bit 2	Bit 1	Bit 0	POR Value	R/W
0x2D	UD_X_TH	Up/Down X Axis Threshold Register	Unsigned value								0x00	W

UD_X_TH[7:0]	Description (~2.9mg/LSB)
0x00	Up/down X threshold offset is 0g
0xFF	Up/down X threshold offset is +0.747g

Table 36. Up/Down X-axis Threshold Register Settings



11.21 RL_Z_TH: RIGHT/LEFT Z AXIS THRESHOLD REGISTER

The threshold value, RL_Z_TH[7:0] is an 8-bit signed 2’s complement number that can range from 0.425g to 1.172g, for determination of the POLA orientation bits. The resolution is approximately 2.9mg/bit. See also Section 9.2 Portrait/Landscape.

Addr	Name	Description	Bit 7	Bit 6	Bit 5	Bit 4	Bit 3	Bit 2	Bit 1	Bit 0	POR Value	R/W
0x2E	RL_Z_TH	Right/Left Z Axis Threshold Register	Signed 2’s complement value								0x00	W

RL_Z_TH[7:0]	Description (~2.9mg/LSB)
0x80	Right/left Z axis threshold is 0.425g
0x00	Right/left Z axis threshold is 0.8g
0x7F	Right/left Z axis threshold is 1.172g

Table 37. Right/Left Z-axis Threshold Register Settings



11.22 RL_Y_TH: RIGHT/LEFT Y AXIS THRESHOLD REGISTER

This 8-bit unsigned value is an offset this is added to the magnitude of the Y-axis accelerometer measurement. The range of the offset is 0g to 0.747g; the resolution is approximately 2.9mg/bit. See also Section 9.2 Portrait/Landscape.

Increasing this value in conjunction with the UD_X_TH: Up/Down X Axis Threshold Register widens the dead-band in portrait /landscape detection.

For most applications, the same value should be written to both registers.

Addr	Name	Description	Bit 7	Bit 6	Bit 5	Bit 4	Bit 3	Bit 2	Bit 1	Bit 0	POR Value	R/W
0x2F	RL_Y_TH	Right/Left Y Axis Threshold Register	Unsigned value								0x00	W

RL_Y_TH[7:0]	Description (~2.9mg/LSB)
0x00	Right/left Y-axis threshold offset is 0g
0xFF	Right/left Y-axis threshold offset is +0.747g

Table 38. Right/Left Y-axis Threshold Register Settings



11.23 FB_Z_TH: FRONT/BACK Z AXIS THRESHOLD REGISTER

The threshold value, FB_Z_TH[7:0] is an 8-bit unsigned number that adds up to + 0.373g to the baseline detection level of 0.174g, in increments of approximately 1.46mg/LSB. Increasing the threshold value increases the hysteresis of the front/back detection level. See also Section 9.3 Front/Back.

Addr	Name	Description	Bit 7	Bit 6	Bit 5	Bit 4	Bit 3	Bit 2	Bit 1	Bit 0	POR Value	R/W
0x30	FB_Z_TH	Front/Back Z Axis Threshold Register	Unsigned value								0x00	W

FB_Z_TH[7:0]	Description (~1.46mg/LSB)
0x00	Front/back Z threshold is 0.174g
0xFF	Front/back Z threshold is 0.547g

Table 39. Front/Back Z-axis Threshold Register Settings



11.24 DROP_TH: DROP THRESHOLD REGISTER

The threshold value, DROP_TH[7:0] is an 8-bit signed 2’s complement number that adjusts the drop-detection baseline detection level of 0.5g. See also Section [9.5 Drop Detection](#).

Addr	Name	Description	Bit 7	Bit 6	Bit 5	Bit 4	Bit 3	Bit 2	Bit 1	Bit 0	POR Value	R/W
0x31	DROP_TH	Drop Threshold Register	Signed 2’s complement value								0x00	W

DROP_TH[7:0]	Description (~2.9mg/LSB)
0x80	Drop threshold is 0.125g
0x00	Drop threshold is 0.5g
0x7F	Drop threshold is 0.872g

Table 40. Drop Threshold Register Settings



11.25 TAP_TH: TAP THRESHOLD REGISTER

The threshold value, TAP_TH[7:0] is an 8-bit unsigned number that species the threshold detection level for all tap events. This value is not an offset, but a magnitude which determines the minimum level for a valid tap event. The detector is implemented as a 2nd-order high pass filter. As such, the units are the 2nd derivative of acceleration, also known as ‘snap’. The full range is 0 to 12 snap. The resolution is ~47 milliSnap/bit. See also Section 9.6 Tap Detection.

Addr	Name	Description	Bit 7	Bit 6	Bit 5	Bit 4	Bit 3	Bit 2	Bit 1	Bit 0	POR Value	R/W
0x32	TAP_TH	Tap Threshold Register	Unsigned value								0x00	W

TAP_TH[7:0]	Description (~47 mSnap/LSB)
0x00	Tap threshold is 0 snap
0x80	Tap threshold is 6 snap
0xFF	Tap threshold is 12 snap

Table 41. TAP_TH Tap Threshold Register Settings



11.26 PCODE: PRODUCT CODE

This register returns a value specific to the part number of this mCube device, noted below.

Addr	Name	Description	Bit 7	Bit 6	Bit 5	Bit 4	Bit 3	Bit 2	Bit 1	Bit 0	POR Value	R/W
0x3B	PCODE	Product Code Register	0x88								0x88	R



12 EXAMPLE CONFIGURATION

This section shows an example configuration, for demonstration purposes. The sequences are described as register read and write cycles; the I2C device ID and protocol are implied.

12.1 EXAMPLE: SHAKE, TAP & DROP THRESHOLDS DEMO

Sequence	Register	Data to Write	Comments
1	0x07	0x43	Go to STANDBY state, configure INTN pin, active low (IAH = 0), active drive (IPP = 1)
2	0x06	0xE4	Enable shake interrupt in X,Y or Z-axis, enable tap interrupt, disable others
3	0x09	0x40	Enable Tap detection on Y-axis
4	0x0A	0x03	Tap detected for pulses > Tap threshold and for 4 or fewer sample periods
5	0x0B	0x00	Set drop mode A, drop debounce set to be 1 drop event, no drop interrupt
6	0x0C	0x1F	Set shake debounce register to 31 adjacent shake events
7	0x20	0x33	Select +/- 2g range at 10-bit resolution; LPF Bandwidth=64Hz; GINT updates at sample rate
8	0x2B	0x44	Set shake threshold to be approximately 1.5g (1.3 + 44 x ~2.9 mg/LSB).
9	0x2C	0x95	Set up/down Z axis threshold to ~0.5g (~60deg)
10	0x2E	0x95	Set right/left Z axis threshold to ~0.5g (~60deg)
11	0x30	0x40	Set front/back Z axis threshold to ~39deg
12	0x31	0xAB	Set drop threshold to < ~0.25g
13	0x32	0x64	Set tap threshold to ~4.7 snap
14	0x07	0x41	Go to WAKE state, enable sampling, configure INTN pin, active low (IAH = 0), active drive (IPP = 1)

Table 42. Tap Demo Register Sequence



To observe the demo:

- Write the registers as shown above.
- Tap the device in the Y-direction
- Observe interrupt trigger and TAPD tap detection bit
- Read TILT: Status Register to reset the Tap interrupt
- Tap the device in the X and Z directions
- Observe no interrupt triggers
- Rotate the device around in 3D-space
- Observe that the up/down/left/right indications trip at a very steep angle (the chip must be tilted a lot in order for UNKNOWN to not be indicated by the hardware)
- Observe that there is very little hysteresis between the FRONT and BACK readings



13 INDEX OF TABLES

Table 1. Order Information.....5

Table 2. Pin Description.....8

Table 3. Absolute Maximum Ratings..... 10

Table 4. Sensor Characteristics..... 11

Table 5. Electrical Characteristics..... 12

Table 6. I2C Electrical and Timing Characteristics..... 13

Table 7. I2C Timing Characteristics..... 14

Table 8. Summary of Resolution, Range, and Scaling 15

Table 9. Operational States 17

Table 10. Forcing Operational States 18

Table 11. Interrupt Support..... 20

Table 12. Detection Logic Event Evaluation 22

Table 13. Portrait/Landscape Event Evaluation Criteria 25

Table 14. Some Approximate X and Y-axis Portrait/Landscape Evaluation Angles and Values 26

Table 15. Some Approximate Z-axis Portrait/Landscape Evaluation Angles and Values 26

Table 16. Portrait/Landscape TILT: Status Register Assignments 27

Table 17. BAFR Bit Assignments in the TILT: Status Register 29

Table 18. Front/Back Event Evaluation 29

Table 19. Approximate Front/Back Evaluation Angles and Values 29

Table 20. SHAKE Event Evaluation (Baseline + Offset) 30

Table 21. Drop Event Evaluation 32

Table 22. Default Tap Event Evaluation..... 34

Table 23. Register Summary..... 40

Table 24. TILT Status Register Settings..... 41

Table 25. Operational State Status Register..... 43

Table 26. Interrupt Enable Register Settings..... 44

Table 27. Mode Register Functionality..... 45

Table 28. TAPEN Register Settings..... 46

Table 29. TAPP Tap Pulse Register Settings..... 47

Table 30. Drop Event Control Register Settings 48

Table 31. SH_DB Shake Debounce Register Settings 49



Table 32. Extended Accelerometer Registers.....	50
Table 33. OUTCFG Resolution and Range Select Register Settings	51
Table 34. SHAKE_TH Threshold Register Settings	58
Table 35. Up/Down Z-axis Threshold Register Settings	59
Table 36. Up/Down X-axis Threshold Register Settings	60
Table 37. Right/Left Z-axis Threshold Register Settings	61
Table 38. Right/Left Y-axis Threshold Register Settings	62
Table 39. Front/Back Z-axis Threshold Register Settings	63
Table 40. Drop Threshold Register Settings	64
Table 41. TAP_TH Tap Threshold Register Settings.....	65
Table 42. Tap Demo Register Sequence	67



14 REVISION HISTORY

Date	Revision	Description
2014-01	APS-048-0026v1.0	First release version.
2014-09	APS-048-0026v1.1	Removed I5 from ordering info.
2014-10	APS-048-0026v1.2	Updated noise spec. Added I2C resistors explicitly to Typical Application Circuit. Cleaned up some whitespace.



15 LEGAL

1. M-CUBE reserves the right to make corrections, modifications, enhancements, improvements and other changes to its products and to this document at any time and discontinue any product without notice. The information contained in this document has been carefully checked and is believed to be accurate. However, M-CUBE shall assume no responsibilities for inaccuracies and make no commitment to update or to keep current the information contained in this document.
2. M-CUBE products are designed only for commercial and normal industrial applications and are not suitable for other purposes, such as: medical life support equipment; nuclear facilities; critical care equipment; military / aerospace; automotive; security or any other applications, the failure of which could lead to death, personal injury or environmental or property damage. Use of the products in unsuitable applications are at the customer's own risk and expense.
3. M-CUBE shall assume no liability for incidental, consequential or special damages or injury that may result from misapplication or improper use of operation of the product.
4. No license, express or implied, by estoppel or otherwise, to any intellectual property rights of M-CUBE or any third party is granted under this document.
5. M-CUBE makes no warranty or representation of non-infringement of intellectual property rights of any third party with respect to the products. M-CUBE specifically excludes any liability to the customers or any third party regarding infringement of any intellectual property rights, including the patent, copyright, trademark or trade secret rights of any third party, relating to any combination, machine, or process in which the M-CUBE products are used.
6. Examples of use described herein are provided solely to guide use of M-CUBE products and merely indicate targeted characteristics, performance and applications of products. M-CUBE shall assume no responsibility for any intellectual property claims or other problems that may result from applications based on the examples described herein
7. Information described in this document including parameters, application circuits and its constants and calculation formulas, programs and control procedures are provided for the purpose of explaining typical operation and usage. "Typical" parameters that may be provided in M-CUBE data sheets and/or specifications can and do vary in different applications and actual performance may vary over time. All operating parameters including "Typicals," must be validated for each customer application by customer's technical experts. In no event shall the information described be regarded as a guarantee of conditions or characteristics of the products. Therefore, the customer should evaluate the design sufficiently as whole system under the consideration of various external or environmental conditions and determine their application at the customer's own risk. M-CUBE shall assume no responsibility or liability for claims, damages, costs and expenses caused by the customer or any third party, owing to the use of the above information.



is a trademark of M-CUBE, Inc.

M-CUBE and the M-CUBE logo are trademarks of M-CUBE, Inc.,

All other product or service names are the property of their respective owners.

© M-CUBE, Inc. 2014. All rights reserved.

