



Current Mode PWM Controller

MC3265N6

Description

MC3265 is a highly integrated current mode PWM control IC optimized for high performance low standby power offline flyback converter applications.

To improve the efficiency, MC3265 works at QR (Quasi-Resonant) mode or fixed frequency(52KHz) while the loading is high and the line voltage is high or low.

At normal loading, MC3265 works at QR mode and the frequency is limited to 95KHz.

To meet the international power conservation requirements, optimized green mode is integrated to improve the efficiency at light or no load conditions with no audible noise.

Slope compensation is integrated to ensure the stability at high load. Lead edge blanking is integrated to prevent the false trigger at the transition of the switch. Soft switching control at the gate drive can improve the EMI performance of the power supply. The Gate-drive output is clamped at 16V to protect the power MOS.

Features

- Frequency jitter function to improve EMI performance of power supply
- No-audible-noise green mode Control
- Multi operation mode: QR, fixed-frequency CCM and green mode.
- Internal Slope Compensation
- Low VDD Startup Current and Low Operating Current
- Leading Edge Blanking
- UVLO
- Gate Max Output Voltage Clamp at 16V
- Overload Protection (OLP).
- Over temperature Protection (OTP).
- Line Compensation Over Current Protection (OCP)

Applications

Offline AC/DC flyback converter for

- Battery Charger
- Power Adaptor
- Set-Top Box Power Supplies
- Open-frame SMPS
- PC 5V Standby Power
- TV Power Supplies Standby

Ordering Information

Device	Package	Shipping
MC3265N6	SOT-23-6L (Pb-free lead plating)	3000 pcs / tape & reel

Typical Application Circuit

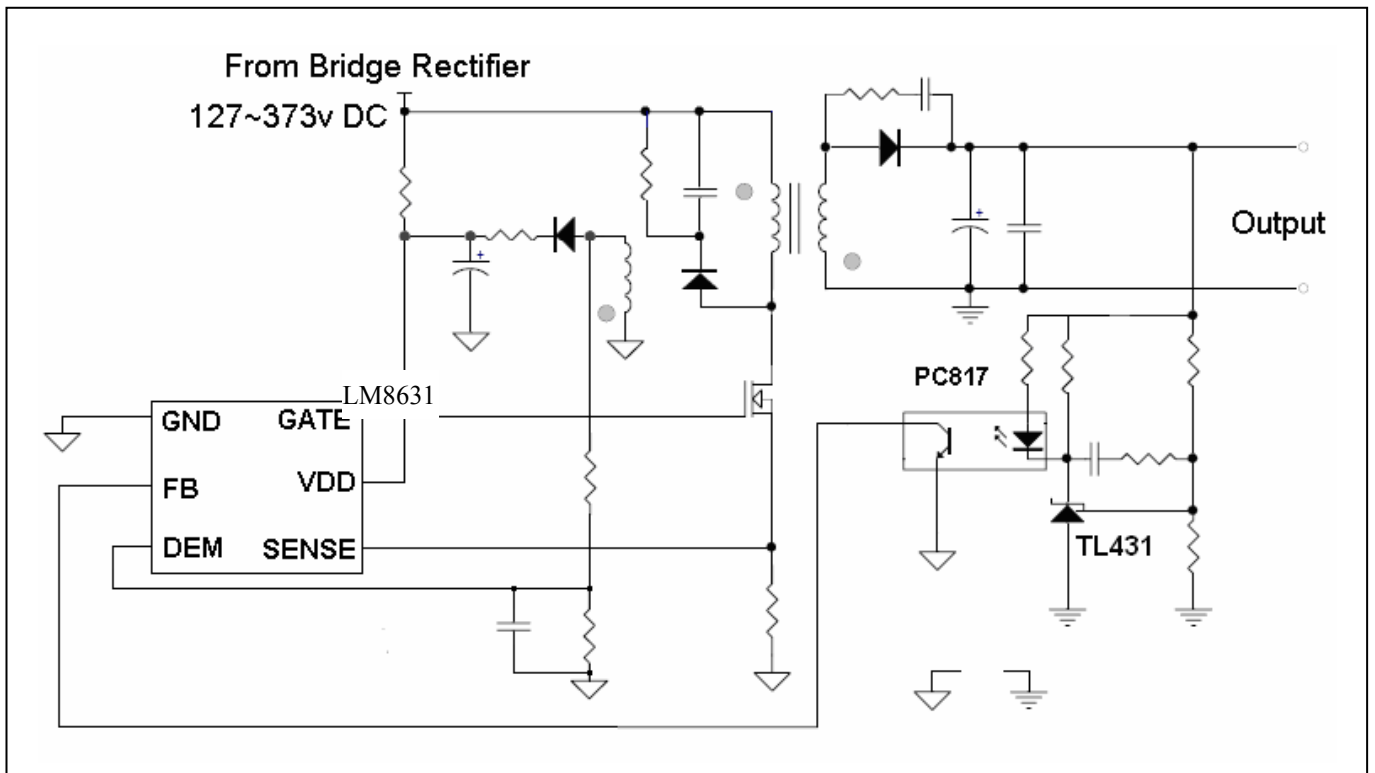

Pin Configuration

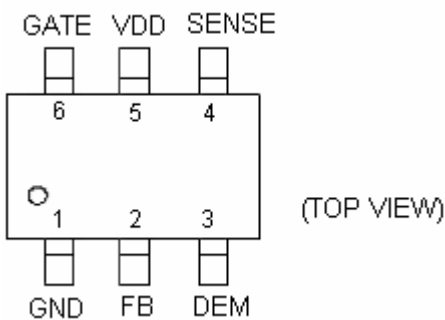

Pin Assignment

Pin Name	Pin Number	Pin Function
GND	1	Ground
FB	2	Feedback input pin. The PWM duty cycle is determined by voltage level into this pin and the current-sense signal at Pin 6.
DEM	3	The 'valley' and output over voltage detect pin.
SENSE	4	Current sense input pin. Connected to MOSFET current sensing resistor node.
VDD	5	Chip DC power supply pin.
GATE	6	Totem-pole gate drive output for the power MOSFET.

Function Block Diagram

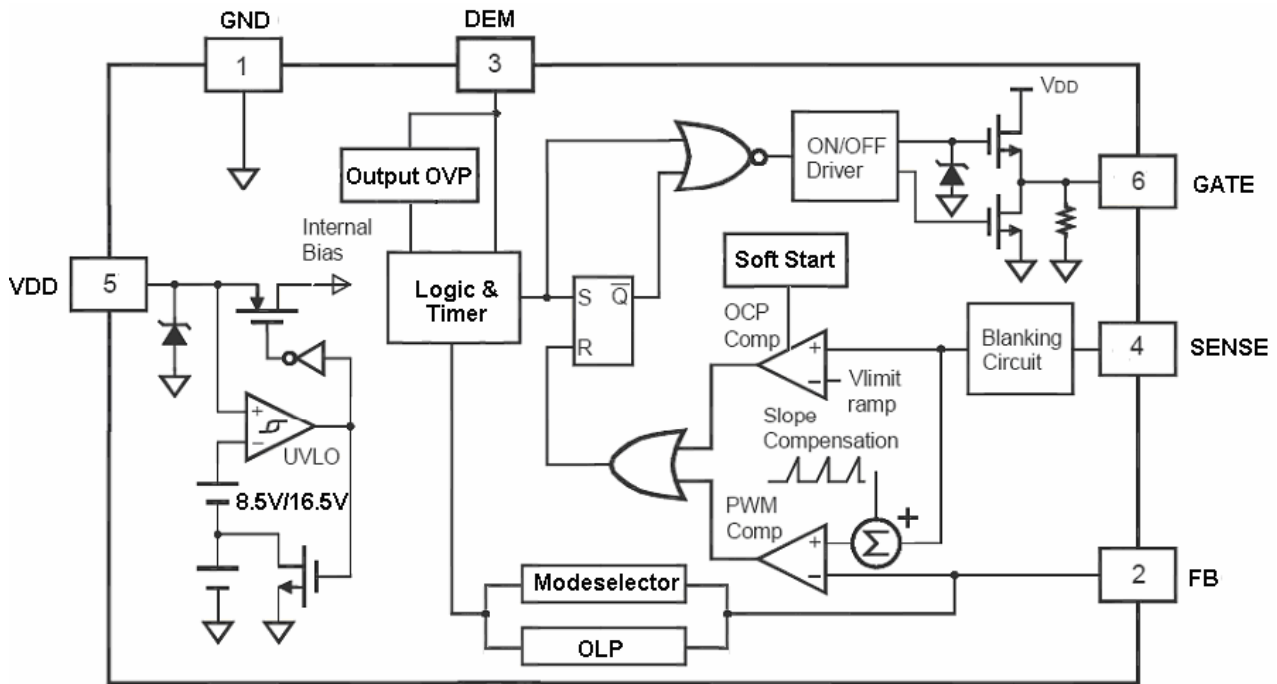

Absolute Maximum Ratings

Parameter	Value	Unit
V _{DD} to GND	29	V
V _{DD} clamped current	10	mA
V _{DD} clamped voltage	29	V
V _{FB} , V _{SENSE} and V _{DEM} to GND	-0.3~+7	V
Maximum Junction Temperature (T _J MAX)	150	°C
Storage Temperature Range	-55 ~ +150	°C

Note : Stresses beyond those listed under "Absolute Maximum Ratings" may cause permanent damage to the device.



Recommended Operating Conditions

- Supply Voltage, V_{DD}.....10V to 30V
- Operating Temperature Range.....-20 °C to 85 °C
- Thermal Resistance ,junction to ambient (R_{thja} @25°C).....250 °C/W

ESD In formations

- Human Body Mode----- 2000V
- Machine Mode----- 200V

Electrical Characteristics (T_A = 25°C, V_{DD}=16V if not otherwise noted)

(T_A = 25°C, V_{DD}=16V if not otherwise noted)

Parameter	Symbol	Test Conditions	Min	Typ	Max	Units
SUPPLY SECTION						
Chip start up current via VDD pin	I _{set}	V _{dd} =12V, measure current into VDD pin		3	20	uA
Operation current	I _{op}	V _{DD} =16V,V _{FB} =3V		1.4		mA
VDD Off(Turn-off threshold)	UVLO_L		7.5	8.5	9.5	V
VDD on(Turn-on threshold)	UVLO_H		14.5	15.5	16.5	V
VDD OVP(Over Voltage Protection)			25	28	28.5	V
VZ(VDD clamp voltage)	V _{DD_CLP}	I _z (I _{dd})=10mA	28.5	29	30	V
FEEDBACK SECTION						
PWM input gain	A _{PWM}	ΔV _{FB} /ΔV _{CS}		3.5		V/V
VFB open loop voltage	V _{FB_O}			5.3		V
FB pin short circuit current	V _{FB_S}	Short FB pin to gnd and measure current		1.1		mA
Burst mode on threshold	V _{BM_on}			0.9		V
Burst mode off threshold	V _{BM_off}			0.8		V
Power limiting FB threshold	V _{FB_th_P}			4.4		V
Power limiting delay time	T _{PL_D}			80		ms
Input impedance	R _{FB}			5		KΩ
TIMER						
Soft start time	T _{soft start}			4		ms
Burst mode switching frequency	F _{burst}			22		KHz
Max frequency in QR mode	F _{max_QR}		80	95	110	KHz
Min frequency in QR mode	F _{min_QR}		47	52	57	KHz
Max on time	T _{on_max}		10	12.5	15	us
Max off time	T _{off_max}		45	60	80	us
CURRENT SENSE SECTION						
Leading edge blanking time	T _{blank}			300	400	nS
Sense pin input impedance	R _{sense}			40		kΩ
Over current threshold voltage at zero duty cycle	V _{TH_OC_0}	FB=3.3V	0.42	0.45	0.48	V



Over current threshold voltage at max. switching on time	VTH_OC_1	FB=3.3V		0.8	0.85	V
Over current protect delay	T_OC_D	CS>VTH_OC, FB=3.3V,CL=1nf @Gate		75		nS
GATE OUTPUT						
Output low level(Turn-off)	VOL	Io=20mA			0.8	V
Output high level(Turn-on)	VOH	Io=20mA	10V			V
Output voltage clamped level	VO_clamp			16		V
Output rising time (10%~90%)	Tr	Cl=1nf		220		nS
Output falling time(90%~10%)	Tf	Cl=1nf		70		ns
DEM Pin						
Dem comparator threshold voltage	Vth_dem			75		mV
Suppression time @ the ringing stage	T_supp			2.5		us
Timeout after last dem. transistion	T_out_dem			5		us
Dem. Propagation delay	T_dem_d			250		ns
Output OVP trigger point	Vth_OVP			3,75		V
Output OVP delay time	T_OVP_de			4		Cycle
OTP						
Thermal shutdown temperature	Tem_off		145	150	160	°C



Characterization Plots

TA = 25°C, VDD=16V if not otherwise noted

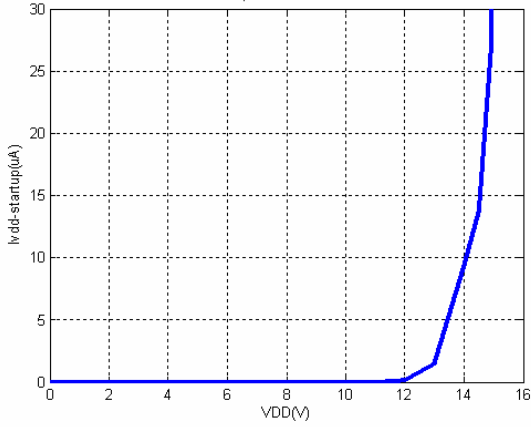

Start Current Vs VDD Voltage

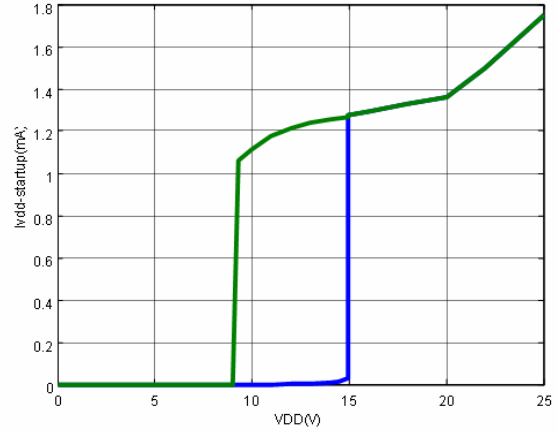

UVLO Voltage & Operation Current

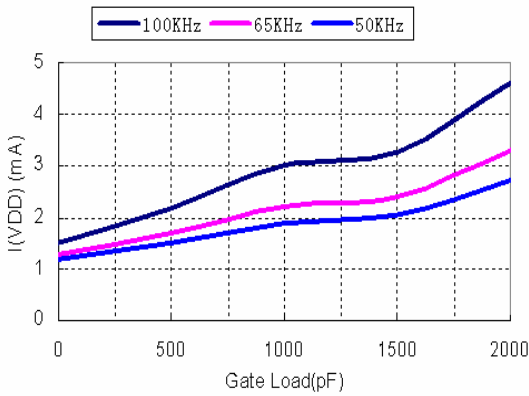

Operation Current VS Load

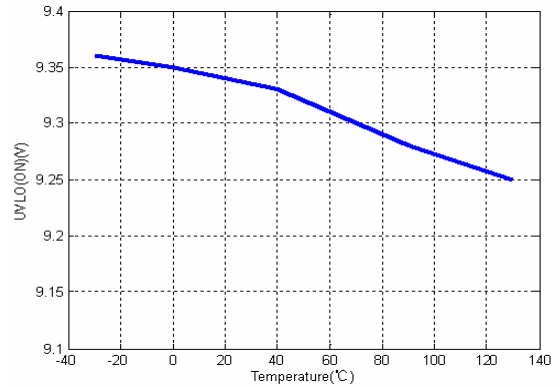

UVLO (On) Voltage VS Temp

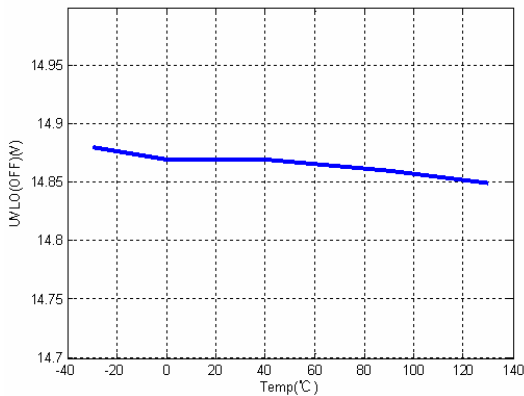

UVLO (Off) Voltage VS Temp

OPERATION DESCRIPTION

Over-view description

The MC3265 includes all necessary function to build an easy and cost effective solution for low power supplies to meet the international power conservation requirements.

Start-up current

Startup current of MC3265 is designed to be very low so that VDD could be charged up above UVLO (exit) threshold level and device starts up quickly. Also a large value startup resistor can be used to minimize the power loss.

Green Mode Operation (Patent)

At light load or no load condition, the switch loss become the major loss of the power supply, to reduce the power wasted in light and no load condition, based on a special designed voltage controlled oscillator, green mode operation of the power supply can be achieved by using MC3265. The controller will judge the load condition base on the voltage of FB pin. In light load the FB voltage will decrease, when VFB is lower than a set threshold voltage, a FB depending time (TR2) will be generated by the oscillator and decrease the operating frequency of the power supply, the minimum frequency is set about 22kHz. The function block and the working waveform can be depicted as below:

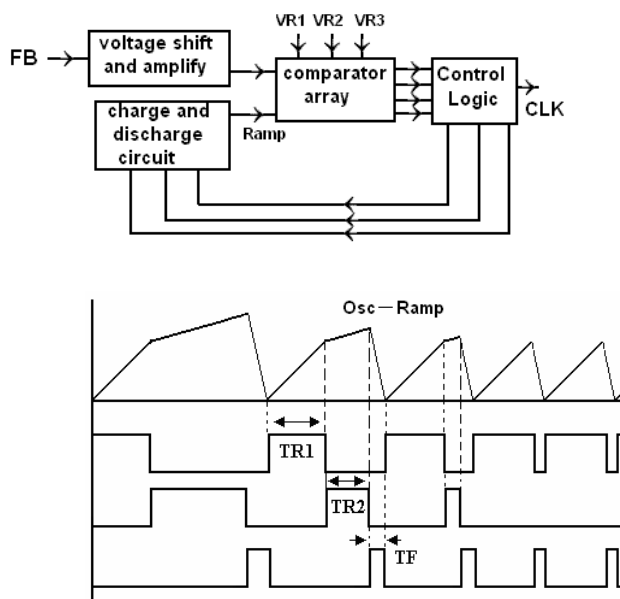

When V_{FB} decrease further, the power supply will enter into burst mode operation to decrease the power consumed at no load condition. Besides there is no audible noise in any load condition.

While MC3265 works in CCM mode, slope compensation and frequency shuffling is activated. The sensed voltage across the sense resistor is used for pwm control, and pulse by pulse current limit, Built-in slope compensation circuit adds a voltage

Multi-mode Operation

MC3265 is a multi-mode QR-PWM controller. The controller changes the mode of operation according to line voltage and load conditions.

At full load and low line input condition, the IC operates in fix frequency(52kHz) CCM mode; At full load and high line input condition, the IC operates in QR mode. Thus, high power conversion efficiency can be achieved in the universal input range when system is at full loading conditions.

At normal loading conditions, the system operates in QR mode (frequency is clamped between 52kHz to 95kHz).

At light load conditions, the system operates in Green mode for high power conversion.

Built-in Slope Compensation and Frequency Shuffling

While MC3265 works in CCM mode, slope compensation and frequency shuffling is activated. The sensed voltage across the sense resistor is used for pwm control, and pulse by pulse current limit, Built-in slope compensation circuit adds a voltage ramp onto the current sense input voltage. This greatly improves the close loop stability and prevents the sub-harmonic oscillation of peak current mode pwm control scheme. To improve the EMI performance, the frequency of CCM mode is shuffling to $52\text{kHz} \pm 5\%$

Line Slope Compensation

Adjusting the RSENSE can set the Max output power of the power supple mode. The current flowing by the power MOSFET has an extra value due to the system delay T that the current detected from the sense pin to power MOSFET cut off in the MC3265. To guarantee the output power is a constant for universal input AC voltage, there is a positive ramp signal to compensate the system delay T and the line input. At lower line-input voltage the higher OCP threshold will bring constant power OCP as below.

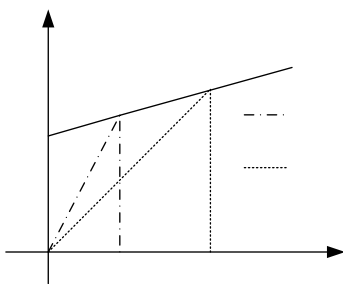

Demagnetization(Dem.) Detection

The transformer core demagnetization is detected by monitoring the voltage waveform on the auxiliary winding through DEM pin. While the voltage on DEM pin is lower than 75mV, Dem. Detection will generate a 'valley' signal and MC3265 make the GATE on depending the condition of FB and SENSE pins. To avoid the ringing of the MOSFET's drain voltage misleading this function, T_{supp} is added. Each time the GATE is off, T_{supp} starts to count. During T_{supp}, GATE remains low and can't be turn to high.



Leading Edge Blanking

Each time when the power MOSFET is switched on, a turn-on spike will inevitably occur on the sense-resistor. To avoid premature termination of the switching pulse, a 300 nsec leading-edge blanking time is built in. Conventional RC filtering can therefore be omitted. During this blanking period, the current-limit comparator is disabled and it cannot switch off the gate driver.

Gate Driver

The output stage of MC3265 is a fast totem pole gate driver. Cross conduction has been avoided to minimize heat dissipation, increases efficiency and enhances reliability. The output driver is clamped by an internal 16V Zener diode in order to protect power MOSFET transistors against undesirable gate over voltage. A soft driving waveform is implemented to minimize EMI.

Protect Functions

To increase the reliability of power supply system many protection functions is integrated in this controller, including Cycle-by-Cycle current limiting (OCP), Over Load Protection (OLP), Over Temperature Protection(OTP), Output Over Voltage Protection (OVP) and over voltage clamp, Under Voltage Lockout on VDD (UVLO). At overload condition when FB input voltage exceeds power limit threshold value for more than TD_PL (power limit debounce time), the controller reacts to shut down the output power MOSFET. Device restarts when VDD voltage drops below UVLO limit. VDD is supplied by transformer auxiliary winding output. It is clamped when VDD is higher than threshold value. The power MOSFET is shut down when VDD drops below UVLO limit and device enters power on start-up sequence thereafter. Pin floating protection for CS, FB, DEM is also added. While one of this happens, the GATE is turned off.

Reel Dimension

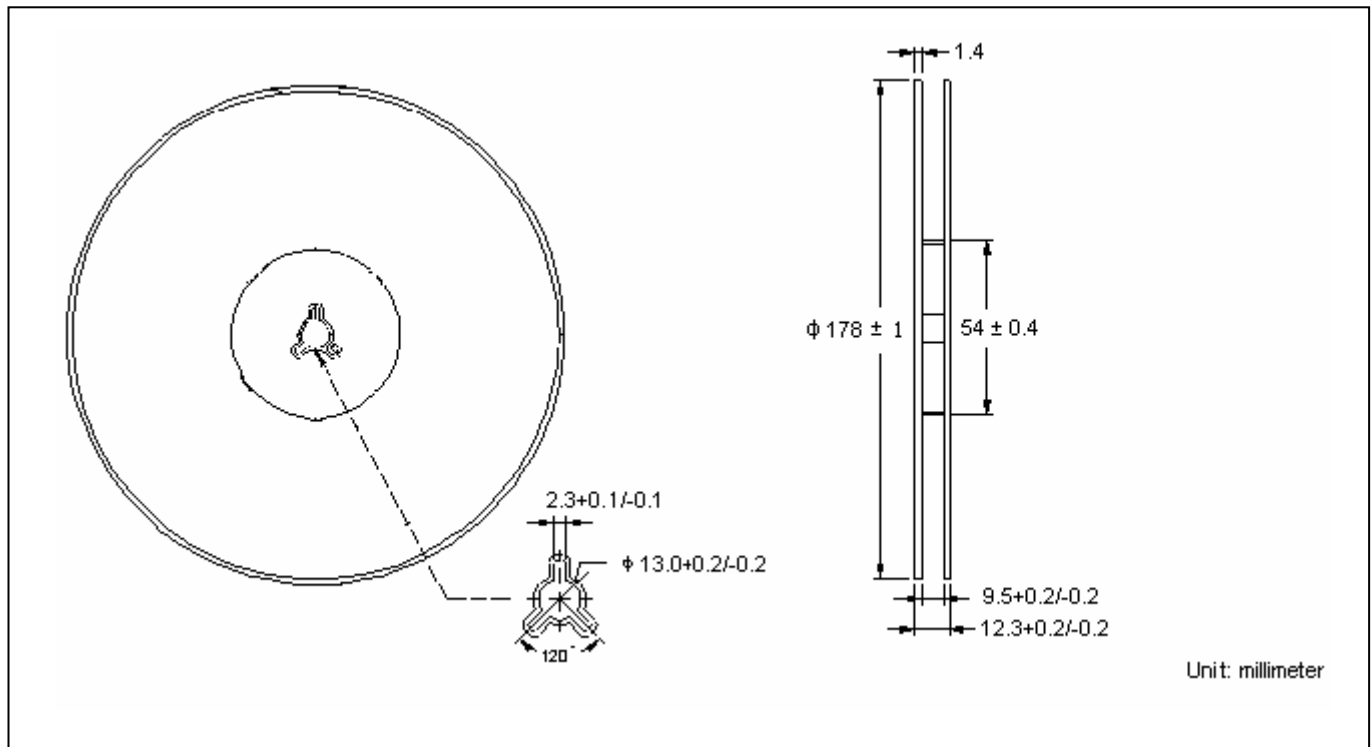

Carrier Tape Dimension

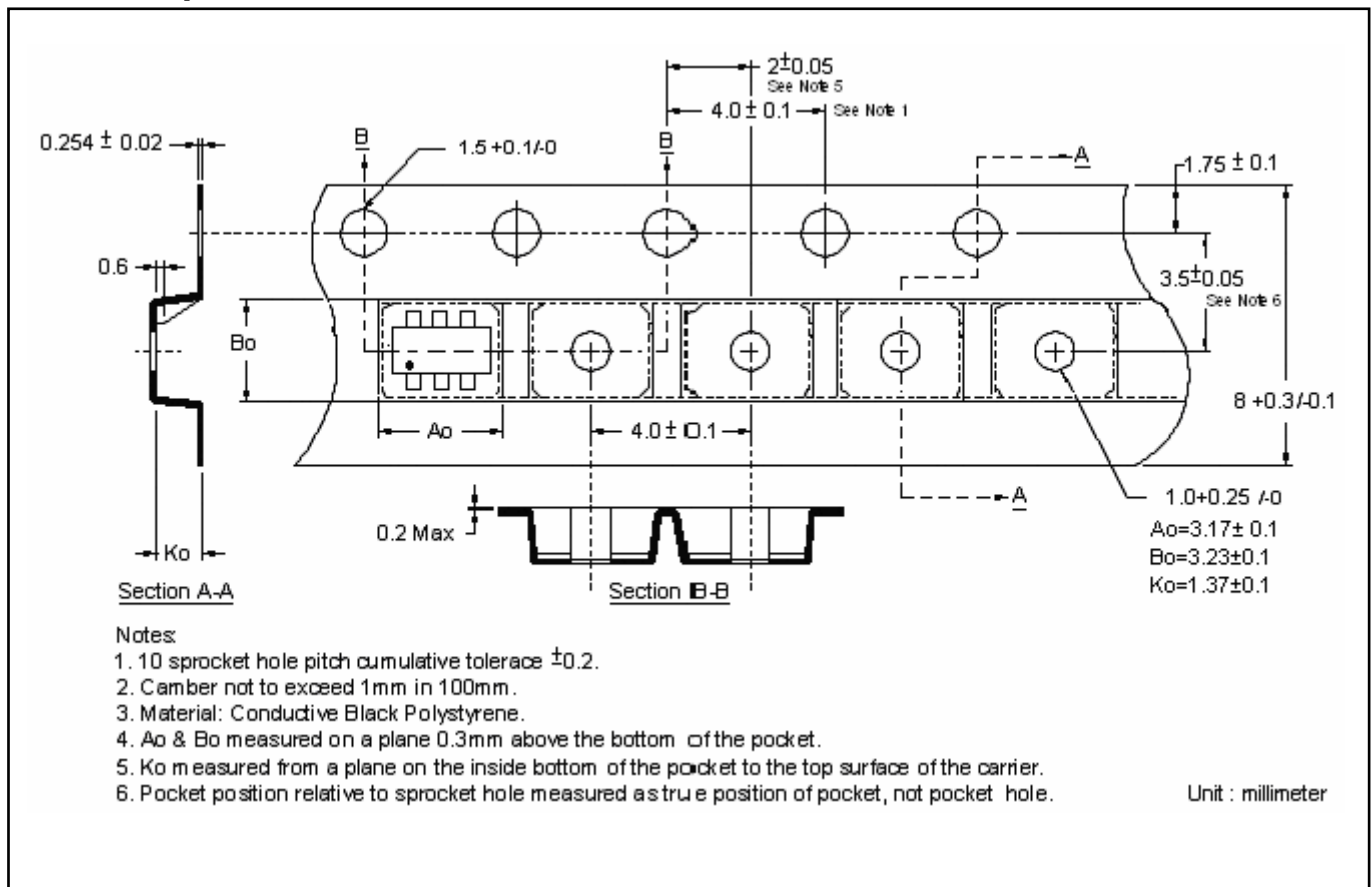

Recommended wave soldering condition

Product	Peak Temperature	Soldering Time
Pb-free devices	260 +0/-5 °C	5 +1/-1 seconds

Recommended temperature profile for IR reflow

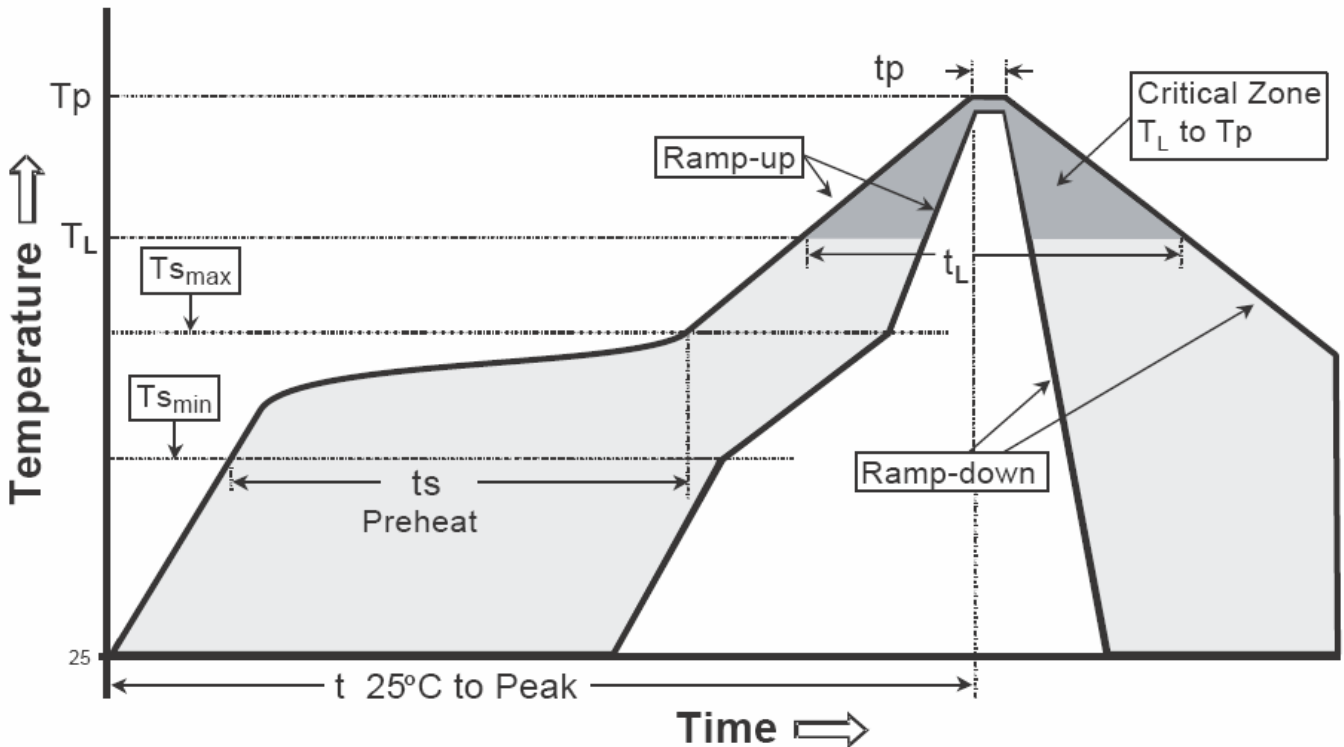

Profile feature	Sn-Pb eutectic Assembly	Pb-free Assembly
Average ramp-up rate (T _{smax} to T _p)	3°C/second max.	3°C/second max.
Preheat		
-Temperature Min(T _{s min})	100°C	150°C
-Temperature Max(T _{s max})	150°C	200°C
-Time(t _{s min} to t _{s max})	60-120 seconds	60-180 seconds
Time maintained above:		
-Temperature (T _L)	183°C	217°C
- Time (t _L)	60-150 seconds	60-150 seconds
Peak Temperature(T _P)	240 +0/-5 °C	260 +0/-5 °C
Time within 5°C of actual peak temperature(t _p)	10-30 seconds	20-40 seconds
Ramp down rate	6°C/second max.	6°C/second max.
Time 25 °C to peak temperature	6 minutes max.	8 minutes max.

Note : All temperatures refer to topside of the package, measured on the package body surface.

SOT-23-6L Dimension

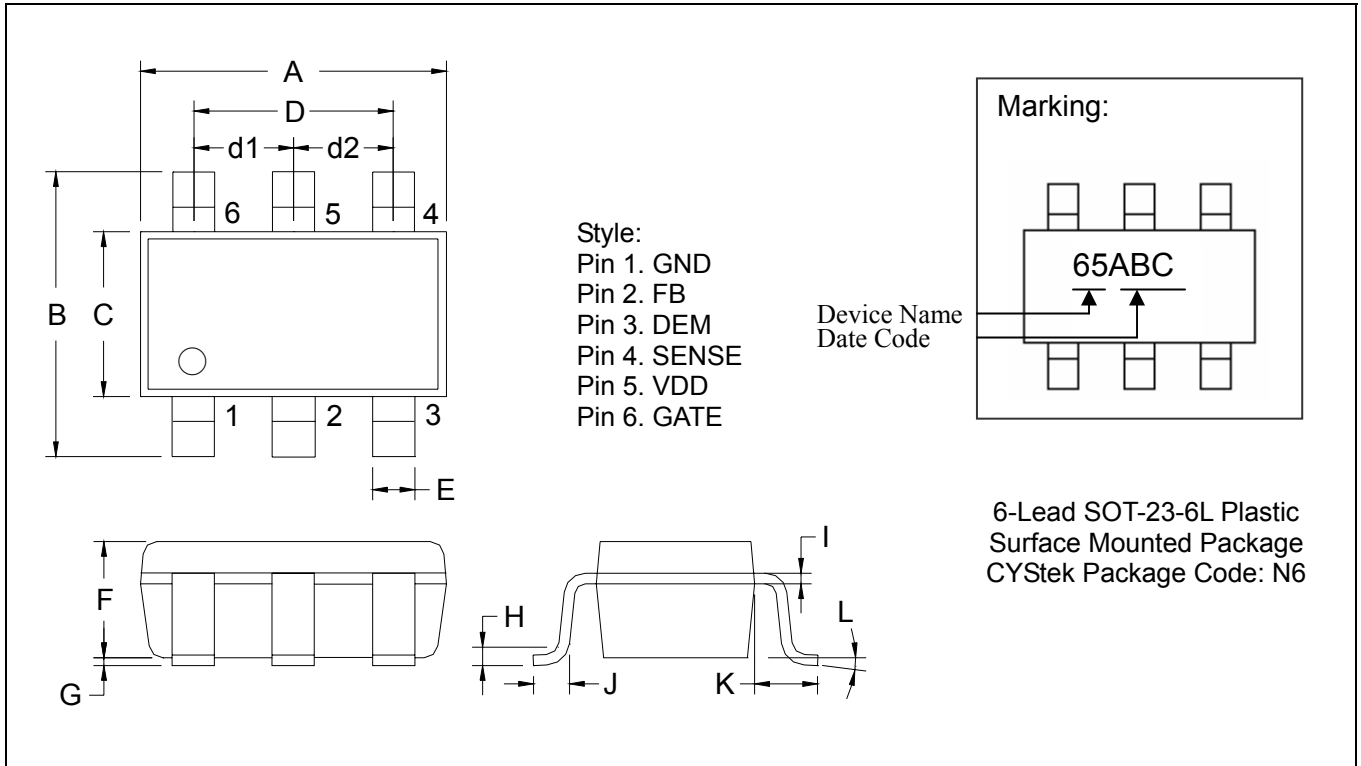

DIM	Inches		Millimeters		DIM	Inches		Millimeters	
	Min.	Max.	Min.	Max.		Min.	Max.	Min.	Max.
A	0.1063	0.1220	2.70	3.10	F	0.0472 REF		1.20 REF	
B	0.1024	0.1181	2.60	3.00	G	0	0.0059	0	0.15
C	0.0551	0.0709	1.40	1.80	H	-	0.0086	-	0.22
D	0.0748 REF		1.90 REF		I	0.0047 REF		0.12 REF	
d1	0.0374 REF		0.95 REF		J	0.0146 REF		0.37 REF	
d2	0.0374 REF		0.95 REF		K	0.0236 REF		0.60 REF	
E	0.0118	0.0217	0.30	0.55	L	0°	10°	0°	10°

Notes : 1.Controlling dimension : millimeters.
 2.Maximum lead thickness includes lead finish thickness, and minimum lead thickness is the minimum thickness of base material.
 3.If there is any question with packing specification or packing method, please contact your local CYStek sales office.

Material :

- Mold Compound : Epoxy resin family, flammability solid burning class:UL94V-0

Important Notice:

- All rights are reserved. Reproduction in whole or in part is prohibited without the prior written approval of CYStek.
- CYStek reserves the right to make changes to its products without notice.
- CYStek **semiconductor products are not warranted to be suitable for use in Life-Support Applications, or systems.**
- CYStek assumes no liability for any consequence of customer product design, infringement of patents, or application assistance.