

Automotive Voltage Regulator

This device is designed for use in conjunction with an NPN Darlington transistor in a floating field alternator charging system.

- Overvoltage Protection
- Shut-Down on Loss of Battery Sense
- Selectable Temperature Coefficient
- Available in Chip Form for Hybrid Assembly

MAXIMUM RATINGS

Rating	Symbol	Value	Unit
Current Into: Pins 5, 6, and 7	I _{5, 6, or 7}	50	mA
Pin 3	I ₃	20	
Pin 4	I ₄	20	
Pin 2	I ₂	120	
Pin 8	I ₈	50	
Pin 9	I ₉	50	
Pin 10	I ₁₀	50	
Junction Temperature	T _J	150	°C
Operating Temperature Range	T _A	-40 to +85	°C
Storage Temperature Range	T _{stg}	-65 to +150	°C

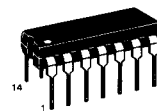

P SUFFIX
PLASTIC PACKAGE
CASE 646

PIN CONNECTIONS

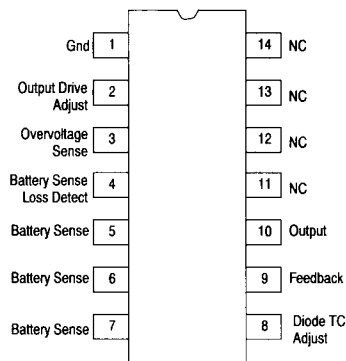

ORDERING INFORMATION

Device	Temperature Range	Package
MC3325P	-40° to +85°C	Plastic DIP

Circuit Schematic

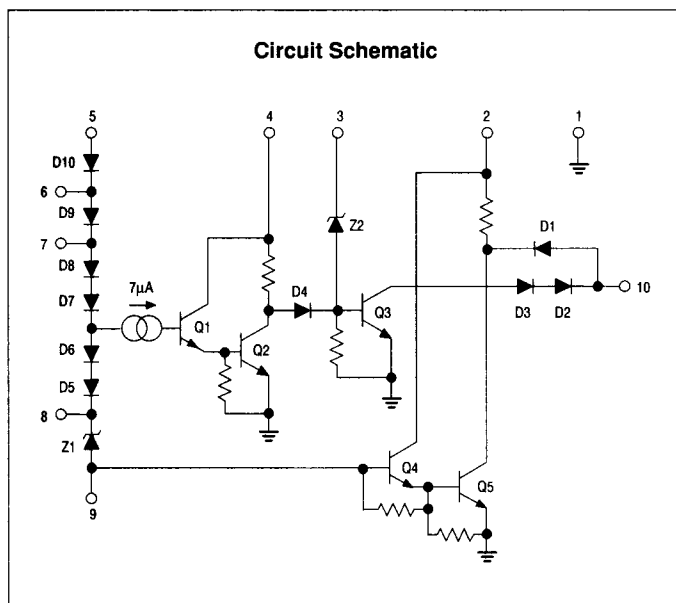

MC3325

ELECTRICAL CHARACTERISTICS (T_A = 25°C, unless otherwise noted.)

Characteristics	Figure	Symbol	Min	Max	Unit
Diode TC Adjust: Threshold Voltage on Pin 8	1	V ₈	7.9	8.95	V
Battery Sense Threshold Voltage on Pin 5	1	V ₅	11.8	13.45	V
Threshold Voltage on Pin 6		V ₆	11.1	12.75	
Threshold Voltage on Pin 7		V ₇	10.5	11.9	
Battery Sense Loss Detect Threshold Current Into Pin 4	2	I ₄	—	600	μA
Threshold Voltage at Pin 4 (I ₄ ≤ 400 μA)		V ₄	1.3	1.7	V
Overvoltage Sense Threshold Current Into Pin 3	2	I ₃	—	600	μA
Threshold Voltage at Pin 3 (I ₃ ≤ 400 μA)		V ₃	6.7	9.0	V
Output Drive Adjust Voltage Drop from Pin 2 to Pin 10 (I ₂ = 10 mA)	3	V ₂	1.9	2.4	V
Low State Output Voltage at Pin 10 (I ₃ = 12 mA, I ₂ = 120 mA)	4	V ₁₀	—	0.7	V

Test Circuits

Figure 1

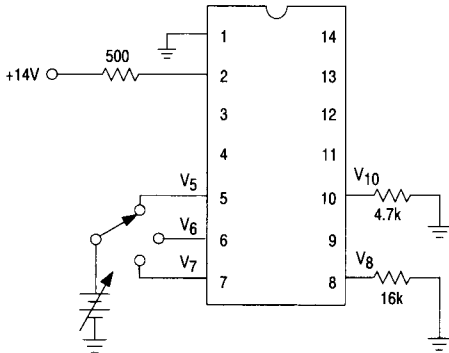

Figure 2

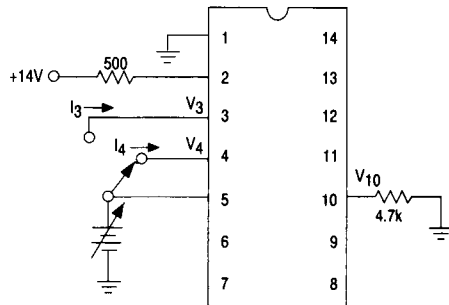

Figure 3

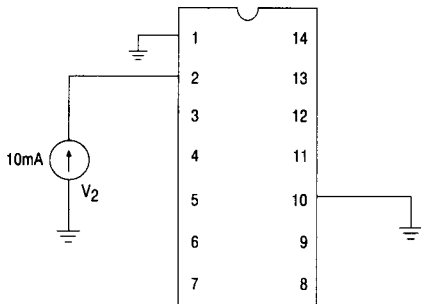
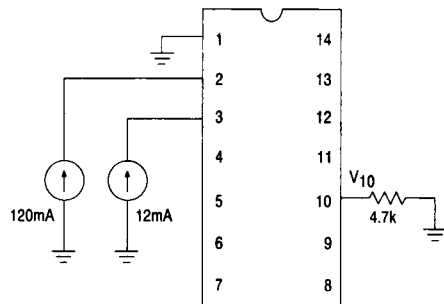

Figure 4



10

MC3325

Applications Circuit Information

R1 — Determines the temperature coefficient by setting the value of current in the diode string. As the value of R1 decreases, so does the effective TC. R1 should be chosen so that the current in the diode string is between 0.5 mA and 1.0 mA.

R2 — This resistor determines the output drive current. Refer to specifications for the darlington driver and select the value for R2 that will provide enough drive to the output when the diode trio voltage is at a minimum.

$$I_{\text{Drive}} \cong \frac{V_{\text{min}} - 2.8 \text{ V}}{R2 + 50 \Omega}$$

R3 — Used as a current limiting resistor on Pin 3 in case of overvoltage at the diode trio. Voltage at Pin 3 will run approximately 7.5 V. R3 should be chosen so that the current (I₃) at maximum overvoltage is between 2.0 mA and 6.0 mA.

R4 — Used as a current limiting resistor on Pin 4 in case of an open battery voltage sense load.

R5 — This resistor determines the V_{Reg} voltage as defined by the following equation:

$$V_{\text{Reg}} = \left(1 + \frac{R5}{R1}\right) 8.4 + \left(n + \frac{R5}{5.0 \text{ k}}\right) (0.7)$$

n = number of diodes used in diode string, (4 ≤ n ≤ 6)

R6 — This resistor in conjunction with R3 is used to set the threshold of overvoltage action.

$$\text{Threshold} \cong \frac{R3 + R6}{R6} (7.5)$$

R7 — Used for compensation (approximately 3.0 kΩ).

C1, C2 — Used for compensation (approximately 0.01 μF).

Figure 5. Application Circuit

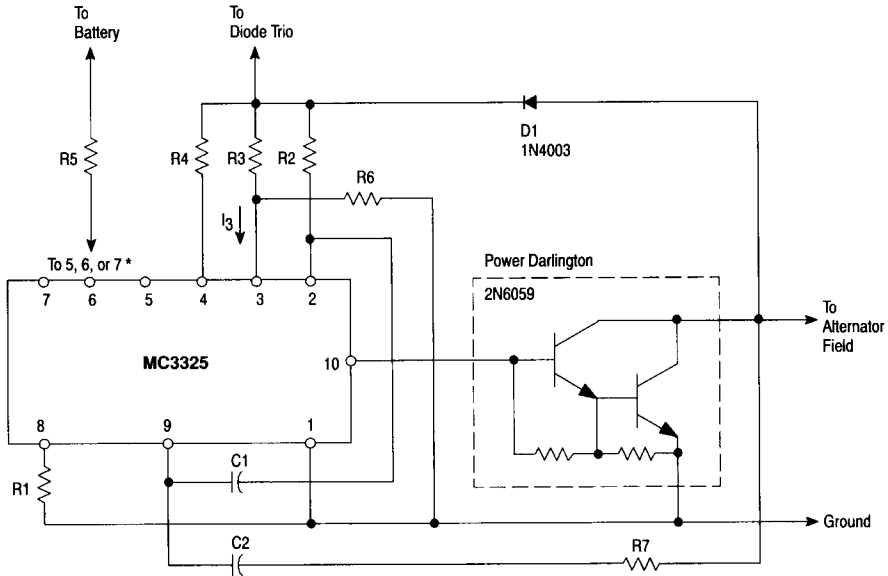

*NOTE: The temperature coefficient of the battery voltage sense terminal is determined by the number of diodes used in the diode string (i.e., whether Pin 5, 6, or 7 is used). The approximate temperature coefficient for a diode at 1.0 mA is $-2.0 \text{ mV}/^\circ\text{C}$, and for a zener diode it is $+3.0 \text{ mV}/^\circ\text{C}$. Counting from ground (see circuit schematic) we have -2.0 mV for Q5, -2.0 mV for Q4, $+3.0 \text{ mV}$ for Z1, -8.0 mV for D5 thru D8, and an additional -2.0 mV each for D9 and D10 if used. The total temperature coefficient can be varied from approximately $-9.0 \text{ mV}/^\circ\text{C}$ to $-13 \text{ mV}/^\circ\text{C}$ depending on the number of the diodes in the diode string that are utilized.